



US00D323296S

**United States Patent** [19]  
**Schoenthaler**

[11] **Patent Number: Des. 323,296**  
[45] **Date of Patent: \*\* Jan. 21, 1992**

[54] **SUPPORT FOR BAGS**

[76] **Inventor: Clifford Schoenthaler, Rte. 3, Box 100A, Norton, Kans. 67654**

[\*\*] **Term: 14 Years**

[21] **Appl. No.: 341,675**

[22] **Filed: Apr. 21, 1989**

[52] **U.S. Cl. .... D9/456; D9/434**

[58] **Field of Search .... D9/456, 424, 341, 434; 248/99; 383/33-34.1; 206/503, 518, 511; 294/1.1-1.3**

[56] **References Cited**

**U.S. PATENT DOCUMENTS**

D. 234,488	3/1975	Wiebe et al. ....	D9/424
2,988,412	6/1961	Vannice .....	206/511
4,457,483	7/1984	Gagné .....	248/99
4,508,768	4/1985	Kornely et al. ....	206/518
4,530,533	7/1985	Dieter .....	294/1.1
4,610,039	9/1986	Stein .....	248/99
4,660,734	4/1987	Heaney et al. ....	206/518
4,815,866	3/1989	Martone .....	383/34.1
4,890,652	11/1990	Hoerner .....	248/99

**OTHER PUBLICATIONS**

Advertisement for Plastic Butler by Starcrest of California.

*Primary Examiner*—B. J. Bullock

*Assistant Examiner*—Dominic Simone

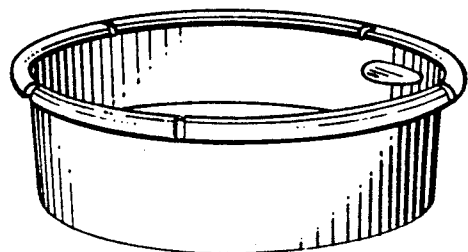
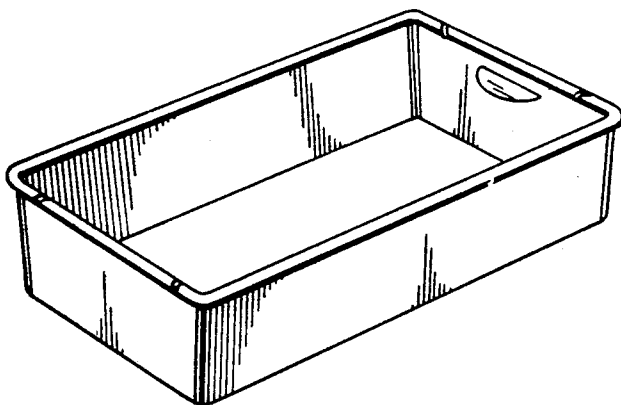
*Attorney, Agent, or Firm*—Litman, McMahon & Brown

[57] **CLAIM**

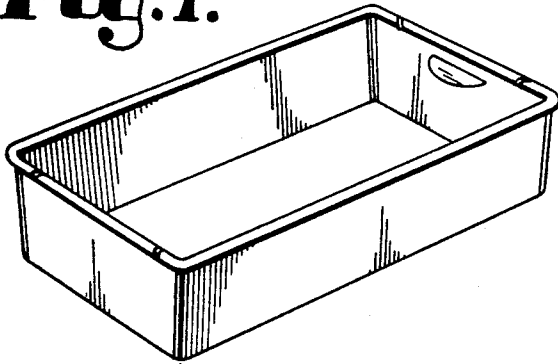
The ornamental design for a support for bags, as shown and described.

**DESCRIPTION**

FIG. 1 is a top, front, right side perspective view of a support for bags, showing my new design;  
 FIG. 2 is an enlarged right side elevational view thereof, the left side being a mirror image;  
 FIG. 3 is an enlarged front elevational view thereof, the rear being a mirrored image;  
 FIG. 4 is an enlarged top plan view thereof;  
 FIG. 5 is an enlarged bottom plan view thereof;  
 FIG. 6 is a top front perspective view of a second embodiment of FIG. 1;  
 FIG. 7 is an enlarged right side elevational view of FIG. 6, the left side being a mirror image;  
 FIG. 8 is an enlarged front elevational view of FIG. 6, the rear being a mirror image;  
 FIG. 9 is an enlarged top plan view of FIG. 6; and  
 FIG. 10 is an enlarged bottom plan view of FIG. 6.



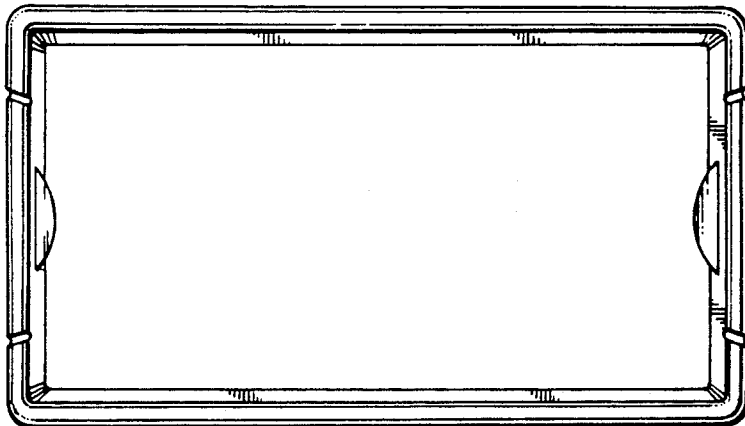
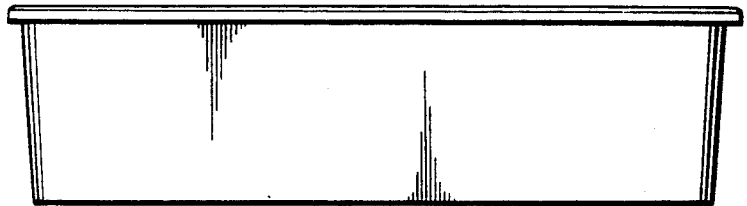
**Fig. 1.**



**Fig. 2.**

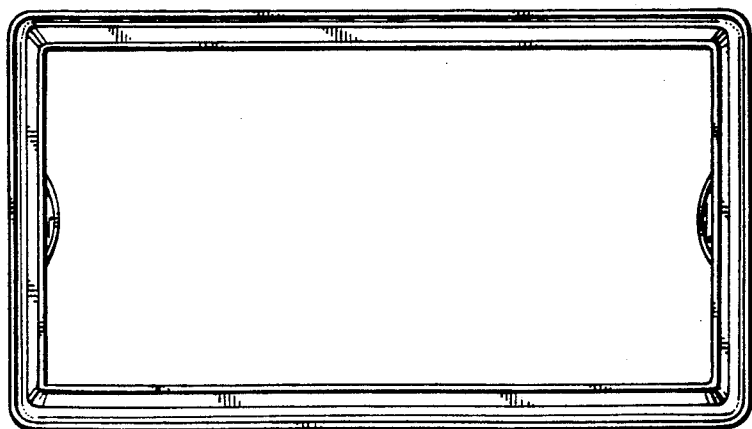


**Fig. 3.**

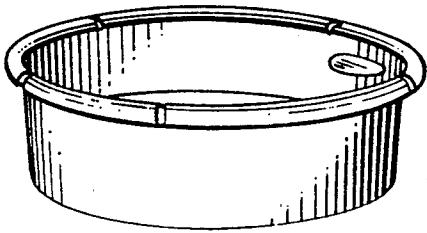


**Fig. 4.**

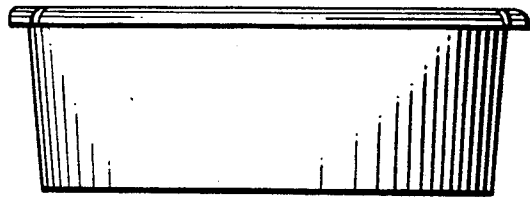
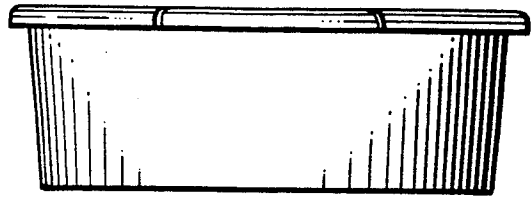
**Fig. 5.**



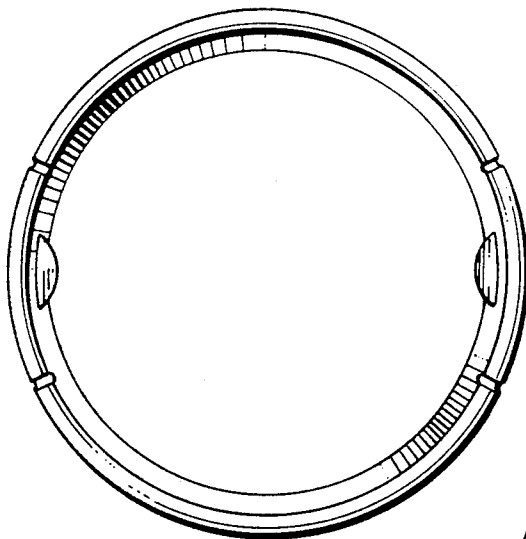
**Fig. 6.**



**Fig. 7.**



**Fig. 8.**



**Fig. 9.**

**Fig. 10.**

