

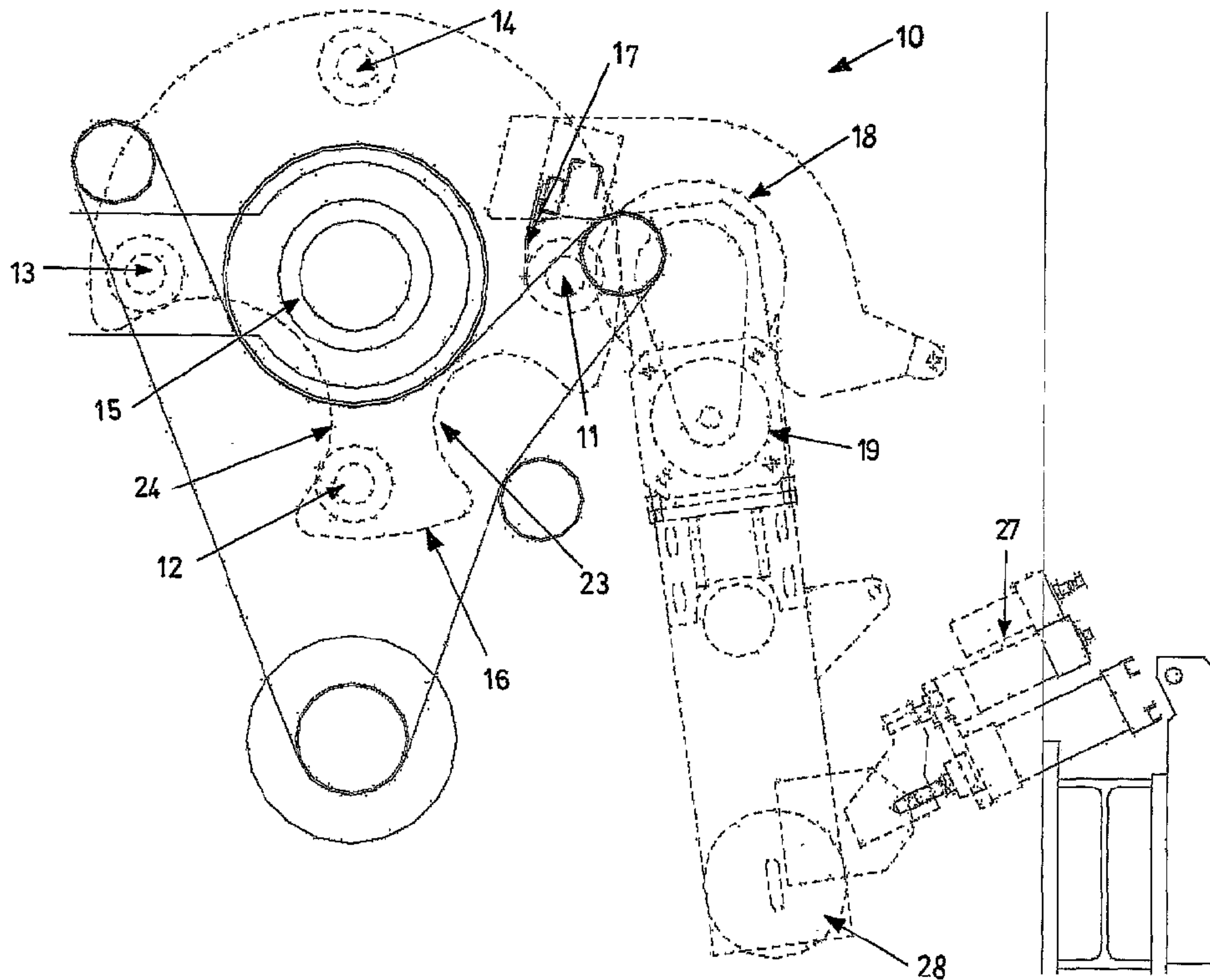

(86) Date de dépôt PCT/PCT Filing Date: 2007/09/19
 (87) Date publication PCT/PCT Publication Date: 2008/04/03
 (45) Date de délivrance/Issue Date: 2013/04/23
 (85) Entrée phase nationale/National Entry: 2009/03/25
 (86) N° demande PCT/PCT Application No.: IB 2007/002811
 (87) N° publication PCT/PCT Publication No.: 2008/038113
 (30) Priorité/Priority: 2006/09/26 (IT MI2006A001814)

(51) Cl.Int./Int.Cl. *B65H 19/22* (2006.01)
 (72) Inventeur/Inventor:
 LOMBARDINI, FRANCESCO, IT
 (73) Propriétaire/Owner:
 COLINES S.P.A., IT
 (74) Agent: ROBIC

(54) Titre : INSTALLATION D'ENROULEMENT DESTINEE A ETRE UTILISEE DANS DES LIGNES DE PRODUCTION DE FILMS, EN PARTICULIER POUR DES FILMS PLASTIQUES EXTENSIBLES, ET PROCEDE D'ENROULEMENT POUR DES ROULEAUX DE FILMS PLASTIQUES
 (54) Title: WINDING PLANT FOR USE IN PLASTIC FILM PRODUCTION LINES, IN PARTICULAR EXTENDABLE PLASTIC FILMS, AND WINDING METHOD OF PLASTIC FILM ROLLS



(57) Abrégé/Abstract:

A winding plant for use in plastic film production lines comprises a plurality of reels (11-14) connected to a star-like reel carrier (15) rotatable around its own axis. According to the invention, said reels (11- 14) are arranged around said star-like reel carrier (15) in a

(57) **Abrégé(suite)/Abstract(continued):**

manner such that at least a first reel (12) of said plurality of reels is situated in an operative winding position of a film (20) to form a complete roll (21). Said reels (11-14) each comprise a mandrel (26) supported by a tailstock associated with a flange element (16) comprising at least a first and a second notch (23,24), wherein said flange element (16) is rotatable around its own axis in a manner independent from said star-like reel carrier (15) when said tails tocks are released from said mandrels (26), so to bring said first notch (23) to a second unloaded reel (13) and said second notch (24) to a third reel (14) loaded with a roll (21) of film (20).

(12) INTERNATIONAL APPLICATION PUBLISHED UNDER THE PATENT COOPERATION TREATY (PCT)

(19) World Intellectual Property Organization
International Bureau(43) International Publication Date
3 April 2008 (03.04.2008)

PCT

(10) International Publication Number
WO 2008/038113 A1(51) International Patent Classification:
B65H 19/22 (2006.01)(21) International Application Number:
PCT/IB2007/002811(22) International Filing Date:
19 September 2007 (19.09.2007)

(25) Filing Language: Italian

(26) Publication Language: English

(30) Priority Data:
MI2006A001814
26 September 2006 (26.09.2006) IT(71) Applicant (for all designated States except US): **COL-
INES S.P.A.** [IT/IT]; Via Prina 3, I-28100 Novara (IT).

(72) Inventor; and

(75) Inventor/Applicant (for US only): **LOMBARDINI,
Francesco** [IT/IT]; Via Parti 8/bis, I-28062 Cameri (IT).(74) Agent: **MARTEGANI, Franco**; Franco Martegani S.r.l.,
Via Carlo Alberto 41, I-20052 Monza (milan) (IT).(81) Designated States (unless otherwise indicated, for every
kind of national protection available): AE, AG, AL, AM,
AT, AU, AZ, BA, BB, BG, BH, BR, BW, BY, BZ, CA, CH,
CN, CO, CR, CU, CZ, DE, DK, DM, DO, DZ, EC, EE, EG,
ES, FI, GB, GD, GE, GH, GM, GT, HN, HR, HU, ID, IL,
IN, IS, JP, KE, KG, KM, KN, KP, KR, KZ, LA, LC, LK,
LR, LS, LT, LU, LY, MA, MD, ME, MG, MK, MN, MW,
MX, MY, MZ, NA, NG, NI, NO, NZ, OM, PG, PH, PL,
PT, RO, RS, RU, SC, SD, SE, SG, SK, SL, SM, SV, SY,
TJ, TM, TN, TR, TT, TZ, UA, UG, US, UZ, VC, VN, ZA,
ZM, ZW.(84) Designated States (unless otherwise indicated, for every
kind of regional protection available): ARIPO (BW, GH,
GM, KE, LS, MW, MZ, NA, SD, SL, SZ, TZ, UG, ZM,
ZW), Eurasian (AM, AZ, BY, KG, KZ, MD, RU, TJ, TM),
European (AT, BE, BG, CH, CY, CZ, DE, DK, EE, ES, FI,
FR, GB, GR, HU, IE, IS, IT, LT, LU, LV, MC, MT, NL, PL,
PT, RO, SE, SI, SK, TR), OAPI (BF, BJ, CF, CG, CI, CM,
GA, GN, GQ, GW, ML, MR, NE, SN, TD, TG).

Published:

- with international search report
- before the expiration of the time limit for amending the
claims and to be republished in the event of receipt of
amendments

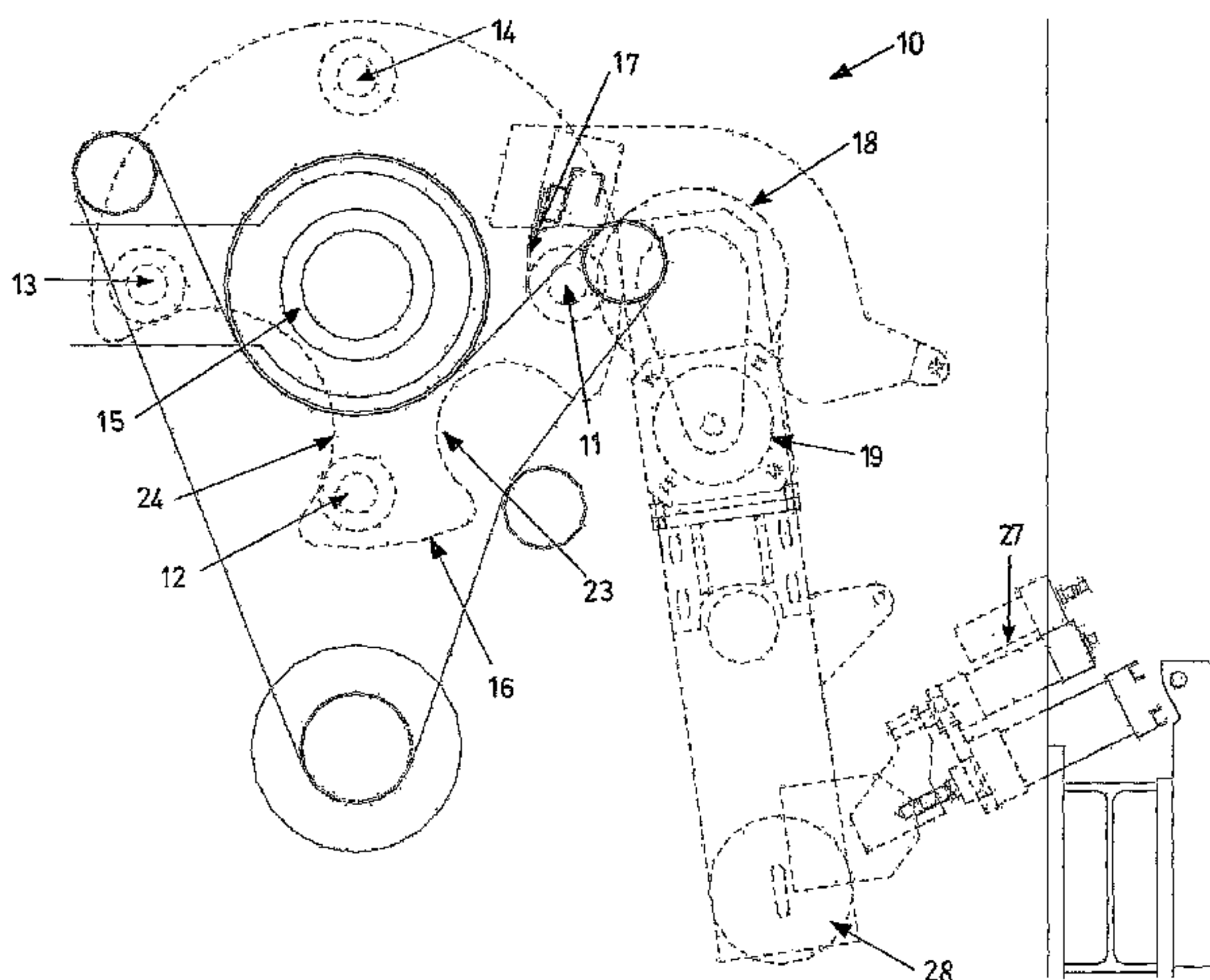
(54) Title: WINDING PLANT FOR USE IN PLASTIC FILM PRODUCTION LINES, IN PARTICULAR EXTENDABLE PLAS-
TIC FILMS, AND WINDING METHOD OF PLASTIC FILM ROLLS

(57) Abstract: A winding plant for use in plastic film production lines comprises a plurality of reels (11-14) connected to a star-like reel carrier (15) rotatable around its own axis. According to the invention, said reels (11- 14) are arranged around said star-like reel carrier (15) in a manner such that at least a first reel (12) of said plurality of reels is situated in an operative winding position of a film (20) to form a complete roll (21). Said reels (11-14) each comprise a mandrel (26) supported by a tailstock associated with a flange element (16) comprising at least a first and a second notch (23,24), wherein said flange element (16) is rotatable around its own axis in a manner independent from said star-like reel carrier (15) when said tails tocks are released from said mandrels (26), so to bring said first notch (23) to a second unloaded reel (13) and said second notch (24) to a third reel (14) loaded with a roll (21) of film (20).

WO 2008/038113 A1

-1-

WINDING PLANT FOR USE IN PLASTIC FILM PRODUCTION LINES,
IN PARTICULAR EXTENDABLE PLASTIC FILMS, AND WINDING
METHOD OF PLASTIC FILM ROLLS

The present invention refers to a winding plant for use
5 in plastic film production lines, in particular
extendable plastic film, and to a winding method of
plastic film rolls.

Extendable plastic film, also called stretch film, is a
widely used product in the packing field, representing
10 the most widespread packing type in Europe and in the
United States.

There are many applications of such film type which
cover most products of common use, both industrially
and in domestic environments.

15 Plastic films are differentiated by their composition,
which permits obtaining films with different
characteristics including toughness, stretching,
ultimate tensile strength, elastic memory, puncture,
and so on.

20 They can be composed of three or more layers
constituted, for example, by mixtures of linear low
density polyethylene (LLDPE), low density and ultra low
density polyethylene (LDPE, VLDPE, ULDPE), metallocene
on polyethylene base (mLLDPE), ethylene-vinyl-acetate
25 in different percentages (EVA from 9% to 20%),
polypropylene homopolymer, copolymer or terpolymer (PP

-2-

homo, PP copo, PP ter) or biodegradable materials
(Mater-Bi).

There are therefore many different formulations
achieved by means of production lines having
5 combinations of two or more extruders in order to
obtain stratifications which can satisfy the
requirements of the applications to which they are
intended.

According to the type and thickness of the film,
10 different application fields can be recognised, the
most important of which including food manufacturers,
pharmaceutical manufacturers, paper factories, tile and
ceramic manufacturers, large distribution, agriculture
and domestic use.

15 Such great variety of use implies an equally wide
variety of film types, both regard to composition and
thickness, generally variable from 12 μm up to over
100 μm , and additionally from the standpoint of the
winding, which presents itself under different forms
20 according to how the film must be subsequently used,
i.e. according to a subsequent manual use, in
automatic, semi-automatic machines and so forth.

For example, in the case of stretch film rolls for
industrial packing, setting aside the film's own
25 mechanical strength and ultimate elongation
characteristics, particular automatic packing machines

-3-

or "palletisers" are used, on which stretch rolls are positioned of well-defined size and weight.

In particular, for this type of application, there are rolls of overall weight of about 12.5 kg which are
5 wound on cardboard cores having inner diameter of about 76 mm and with a strip width equal to about e 500 mm.

In the same manner, the rolls for manual use have instead cores of inner diameter equal to 50 mm and overall weight of about 2.5 kg, thus resulting more
10 manageable.

One particular need of the sector is therefore the optimisation of the plastic film production line so to obtain the best return of such lines, automating them as much as possible to reduce the error possibility to
15 a minimum, speeding up the production and at the same time preserving the high flexibility characteristics.

The flexibility of the lines, in particular, assumes increasing importance if one considers that for reducing to a minimum the enormous logistic expenses
20 for storage, transport and so on, one always tends towards a "just in time" production. One such production strategy is possible only if the plants are capable of offering a flexibility sufficient for producing film rolls which are differentiated by film
25 or winding type, with minimal time loss in particular during the procedures of equipment change, start-up,

-4-

and unloading of the production lines.

The plastic film production lines comprise extrusion and cooling plants constituted by a variable number of extruders, according to the characteristics which it is
5 desired to give to the product, downstream of which winding plants are positioned which receive the extruded and cooled film and wind it into rolls.

The extrusion and cooling part does not present particular difficulties in terms of flexibility, but
10 with the high costs requires having very high production volumes, considering the fact that the final products have a very limited added value, such that for reaching sufficient operating margins it is necessary to utilise the effects of a large scale production.

15 To such end, there is the need to produce plastic films at extremely high actual speeds, close to if not greater than 500 m/min.

The winding plants downstream of the extrusion and cooling plants must therefore have a sufficient winding
20 capacity such to provide for the quantity of film produced over time.

The winding of the film at high speeds, therefore, leads to the physiological presence of air trapped between the laps, which in fact makes the subsequent
25 use of the film itself difficult, representing in any case a waste of space in transport.

-5-

In fact, the very reduced added value of such products ensures that the transport cost has a considerable affect on the production costs, thus also for this reason, in addition for the practical film usability 5 reasons given above, "hard" and compact rolls are required, i.e. without air interposed between the laps. In particular, in the case of a stretch film, the very nature of the film (very sticky) moreover renders obligatory the contact winding, i.e. with the 10 "squeezing" of the roll against a motorised cylinder which favours the expulsion of the air inevitably picked up by the film itself in its winding motion around the mandrel.

To increase the line winding capacity, it was therefore 15 found that the winding of so-called "jumbo" rolls was easier; such rolls have a strip equal to 500 mm but outer diameter up to 500 mm and beyond, which even if wound at a reduced speed which favours the side evacuation of the air otherwise present in the laps, 20 keeps the winding capacity high due to their high diameter dimensions.

The need to have high speed productions, then, would impose, in the case of line production of small diameter (i.e. small measurement) rolls for manual use, 25 very frequent changes (unloading of completed roll and loading of a new core), on the order of a few seconds,

which have always represented the maximum limit for the production speed of the entire line.

The general object of the present invention is to resolve the abovementioned drawbacks of the prior art in an extremely simple, economical and particularly functional manner.

10 Another object is that of devising a winding plant for use in plastic film production lines which is capable of ensuring a high production speed, further reducing the necessary times for the above-defined change steps. Not the least object is that of ideating a plastic film winding method in which the steps of unloading a completed roll and loading a new core occur in reduced times.

20 In view of the aforesaid objects, according to the present invention, it has been thought to make a winding plant for use in plastic film production lines and a related winding method having the characteristics set forth in the attached claims.

According to an aspect of the present invention, there is provided a winding plant for use in plastic film production lines comprising a plurality of reels connected to a star-like reel carrier rotatable around its own axis, said reels being arranged around said star-like reel in a manner such that at least a first reel of said plurality of reels is

6a

situated in an operative winding position of a film to form a complete roll, said reels each comprising a mandrel supported by a tailstock associated with a flange element comprising at least a first and a second notch, wherein said flange element is rotatable around its own axis in a manner independent from said star-like reel carrier when said tailstocks are released from said mandrels, so to bring said first notch to a second unloaded reel and said second notch to a third reel loaded with a roll of film.

According to another aspect of the present invention, there is provided a method for driving a winding plant as described above for use in plastic film production lines,
10 comprising the steps which consist of:

- a) bringing the first reel loaded with a core into winding position and winding said film around said core at a winding speed;
- b) releasing said tailstocks from said mandrels;
- c) rotating said flange element so to bring said first notch to the second unloaded reel and said second notch to the third reel loaded with the complete roll of film;
- d) unloading said complete roll from said third reel and simultaneously loading a new core on said second reel;
- e) rotating said flange element so to bring said tailstocks to couple with said
20 mandrels.

The structural and functional characteristics of the present invention and the advantages with regard to the prior art will be clearer from an examination of the following description, referred to the attached drawings, which show a winding plant for use in plastic film production lines made according to the innovative principles of the invention itself.

-7-

In the drawings:

- Figure 1 shows a section view of a winding plant according to the present invention;
- Figure 2 shows a schematic view of the winding plant of figure 1 during the winding step of a first roll;
- Figure 3 is a schematic view of the winding plant of figure 1 following the winding reel change step;
- Figure 4 is a schematic view of the winding plant of figure 1 in configuration of unloading a wound roll and loading a new core;
- Figure 5 is a schematic view of the winding plant of figure 1 during the winding step of a second roll.

With reference to the drawings, the winding plant, object of the invention is indicated overall with 10.

Such plant 10 comprises star-like reel carrier 15 to which up to four reels 11-14 are bound, arranged around the star-like reel carrier 15, for example at pitches of 90°, respectively.

Alternatively, three single reels can be provided for, arranged around the star-like reel carrier 15, for example at pitches of 120°, respectively.

At one end of the reels 11-14, a star-like flange 16 is moreover provided which bears the tailstocks (not illustrated) which support the mandrels 26 of the reels 11-14. Such star-like flange 16, substantially with circular surface, has two notches 23, 24 on its

- 8 -

perimeter edge which are substantially circular-sector shaped. Such notches 23,24 are appropriately sized so to respectively facilitate the passage of a core 22 around which a film 20 is wound and a completely wound
5 roll 21 of film 20.

At a determined so-called winding angular position, which in the embodiment illustrated corresponds with the position in figure 1 of a first reel 11, an appropriate motorisation is provided for, adapted to
10 drive the winding of the film 20 at a determined winding speed around the reel which is found in such angular position, as well as a drawing and pressure device adapted to regulate the tensioning of the film
20 during the winding.

15 Such drawing and pressure device comprises at least one cylinder 18 which during the winding of the film 20 on the reel is in contact with the respective reel and makes, together with a gummed roller 19, a drawing device of the film 20 itself.

20 The aforesaid device is free to rotate, during the winding and roll change step, around the axis identified by the torsion bar 28 in order to always maintain the same contact pressure controlled by the pneumatic pistons 27.

25 Moreover, at the winding position, a blade 17 is provided for, for cutting the film 20 following the end

-9-

of the winding step of an entire roll 21 of film.

The extraction and re-entry of the transverse cutting blade is controlled by a pair of pneumatic cylinders, not indicated in the figure.

5 The functioning of the winding plant according to the invention will now be described with reference to an embodiment bearing four reels 11-14.

During the normal functioning, the film 20 is wound on the reel 11 which is found in winding position, i.e. in
10 contact with the drawing and pressure device (see figure 2).

As shown in figure 2, during the winding of a roll on the reel 11, on a further reel 14 there is present a roll which had been previously wound, which is found in
15 a wait position for the next unloading.

At the end of such first step, i.e. when the film roll 21 is completed, the so-called change step takes place, in which initially a second reel 12 is wound at a peripheral speed slightly greater than the winding
20 speed and subsequently the star-like reel carrier 15 rotates 90°, for example in anticlockwise sense with reference to the view of figure 1, bringing the second reel 12 to the winding position (see figure 3).

The rotation speed of the star-like reel carrier 15,
25 adding to the peripheral speed of the reel 11, ensures that the film 20 is further tensioned.

-10-

Such rotation moreover brings the film 20 to the blade 17 which, due to the over-tensioning, is capable of cutting the film 20 without risking that it is lost in the passage from the first 11 to the second 12 reel.

5 To such end, the second reel 12 is moreover preloaded by means of an electrostatic discharge, in such a manner being able to attract the film 20 thereto without the need for glues or adhesives.

As soon as the change step is finished, the star-like
10 flange 16 extracts the tailstocks which support the mandrels 26 and rotates 90°, plus another angular portion depending on the final plant geometry, in the sense opposite to the rotation of the star-like reel carrier 15, so to have notches 23 and 24 respectively
15 at a third reel 13 which is in stand-by and fourth reel 14 bearing the previously wound roll 21 and now ready to be unloaded.

The star-like flange 16 thus positions itself in a manner such to permit the loading of a new core 22 on
20 the third reel 13 and simultaneously the unloading of the previously wound roll 21 on the further reel 14 (see figure 4).

During the rotation of the star-like flange 16, the second winding reel 12 is supported by a suitable quick
25 clip system, which provides to maintain its position with suitable characteristics corresponding to the

-11-

contact cylinder 18.

The completed roll 21 unloading operation and new core 22 loading operation take place simultaneously by means of suitable mechanical actuators which operate at 5 sustained speeds.

Due to the plant according to the invention, such operations generally have a maximum duration of about 15 seconds.

At the end of the simultaneous completed roll 21 10 unloading and new core 22 loading operations, the star-like flange 16 rotates in the sense opposite that of its initial rotation, so to bring the tailstocks into work position at the nearest mandrel 26.

The entire process described here takes place in very 15 rapid times and it is therefore required that the driving occurs by means of a particularly sensitive control and management device. In such a manner, it is possible to manage the tensions on the film 20 during the change step, such to prevent air-trapping 20 phenomena.

Moreover, to further improve the final aspect of the roll 21, the use of an external rolling device (not shown) is advantageously envisaged, device which acts on the winding roll 21 and which follows it during the 25 change step, in particular when the winding roll 21 is not in contact with the cylinder 17.

-12-

Such system is implemented by means of a pneumatic or hydraulic lever system with a high frequency control, so to constantly accompany the motion of the roll 21 during the rotation of the star-like reel carrier 15.

5 Such rolling system can be constituted by a single additional contact roller which acts exclusively on the roll in winding step, integral therefore with the fixed structure of the machine: the movement, is characterised by different degrees of freedom since it
10 must follow the rotary motion of the star-like reel carrier 15, which however cannot have the axial rotation centre with the rolling system itself.

Alternatively, the rolling can be carried out with the use of an additional roller for every single reel,
15 hence integral with the star-like reel carrier and equipped with a system of approaching and contact with the roll composed of a simpler leverage.

From that described above with reference to the figures, it is evident how a winding plant for use in
20 plastic film production lines according to the invention is particularly useful and advantageous. The object mentioned in the description preamble is thus attained.

With the winding plant according to the invention it is
25 possible to produce plastic film rolls with extremely reduced measurements due to the rapid times necessary

-13-

for the operations of unloading the completed rolls and loading new cores which, in the described plant, can take place simultaneously.

The winding plant according to the invention can be prearranged both for winding rolls with inner core equal to 50 mm, i.e. of rolls for manual use, and for the winding of rolls on 76 mm cores, i.e. rolls for use on automatic machines, thus offering a high level of flexibility.

10 It can also be used in pairs with a checkerboard arrangement of the winders, which also permits the simultaneous production of two rolls on 50 mm mandrels and two rolls on 76 mm mandrels, further increasing the flexibility of the production lines, due to the possibility to differentiate the final manufacturing results without changing any line parameter.

The protective scope of the invention is therefore defined by the attached claims.

WHAT IS CLAIMED IS:

1. Winding plant for use in plastic film production lines comprising a plurality of reels (11-14) connected to a star-like reel carrier (15) rotatable around its own axis, said reels (11-14) being arranged around said star-like reel (15) in a manner such that at least a first reel (12) of said plurality of reels is situated in an operative winding position of a film (20) to form a complete roll (21), said reels (11-14) each comprising a mandrel (26) supported by a tailstock associated with a flange element (16) comprising at least a first and a second notch (23,24), wherein said flange element (16) is rotatable around its own axis in a manner independent from said star-like reel carrier (15) when said tailstocks are released from said mandrels (26), so to bring said first notch (23) to a second unloaded reel (13) and said second notch (24) to a third reel (14) loaded with a roll (21) of film (20).
2. Winding plant for use in plastic film production lines according to claim 1, characterised in that said first notch (23) is circular-sector shaped and has size substantially similar to the section size of the mandrel (26).
3. Winding plant for use in plastic film production lines according to claim 1 or 2, characterised in that said second notch (24) is circular-sector shaped and has size substantially similar to the section size of the complete roll (21).
4. Winding plant for use in plastic film production lines according to any one of claims 1 to 3, characterised in that it comprises a blade element (17) for the cutting of said film (20) following the completion of said roll (21).
5. Winding plant for use in plastic film production lines according to any one of claims 1 to 4, characterised in that it comprises a drawing and pressure device comprising at least one cylinder (18) arranged in contact with said first reel (12) in operative winding position, said drawing and pressure device being rotatable around a torsion axis (28) and being controlled under pressure through cylinders (27).

6. Winding plant for use in plastic film production lines according to any one of claims 1 to 5, characterised in that it comprises at least one rolling device adapted to follow the rotation of said completed roll (21) moving away from said winding position, said rolling device comprising at least one roller integral with said winding plant (10).

7. Method for driving a winding plant for use in plastic film production lines according to any one of claims 1 to 6, comprising the steps which consist of:

- a) bringing the first reel (12) loaded with a core (22) into winding position and winding said film (20) around said core (22) at a winding speed;
- 10 b) releasing said tailstocks from said mandrels (26);
- c) rotating said flange element (16) so to bring said first notch (23) to the second unloaded reel (13) and said second notch (24) to the third reel (14) loaded with the complete roll (21) of film (20);
- d) unloading said complete roll (21) from said third reel (14) and simultaneously loading a new core (22) on said second reel (13);
- e) rotating said flange element (16) so to bring said tailstocks to couple with said mandrels (26).

8. Method for driving a winding plant according to claim 7, characterised in that during the steps b)-d), said first reel (12) is maintained winding by a quick clip
20 device.

9. Method for driving a winding plant according to claim 7 or 8, characterised in that it additionally comprises the steps which consist of:

- f) starting said second reel (13) loaded with said core (22) at a peripheral speed which is greater than said winding speed;
- g) preloading said second reel (13) by means of an electrostatic discharge.

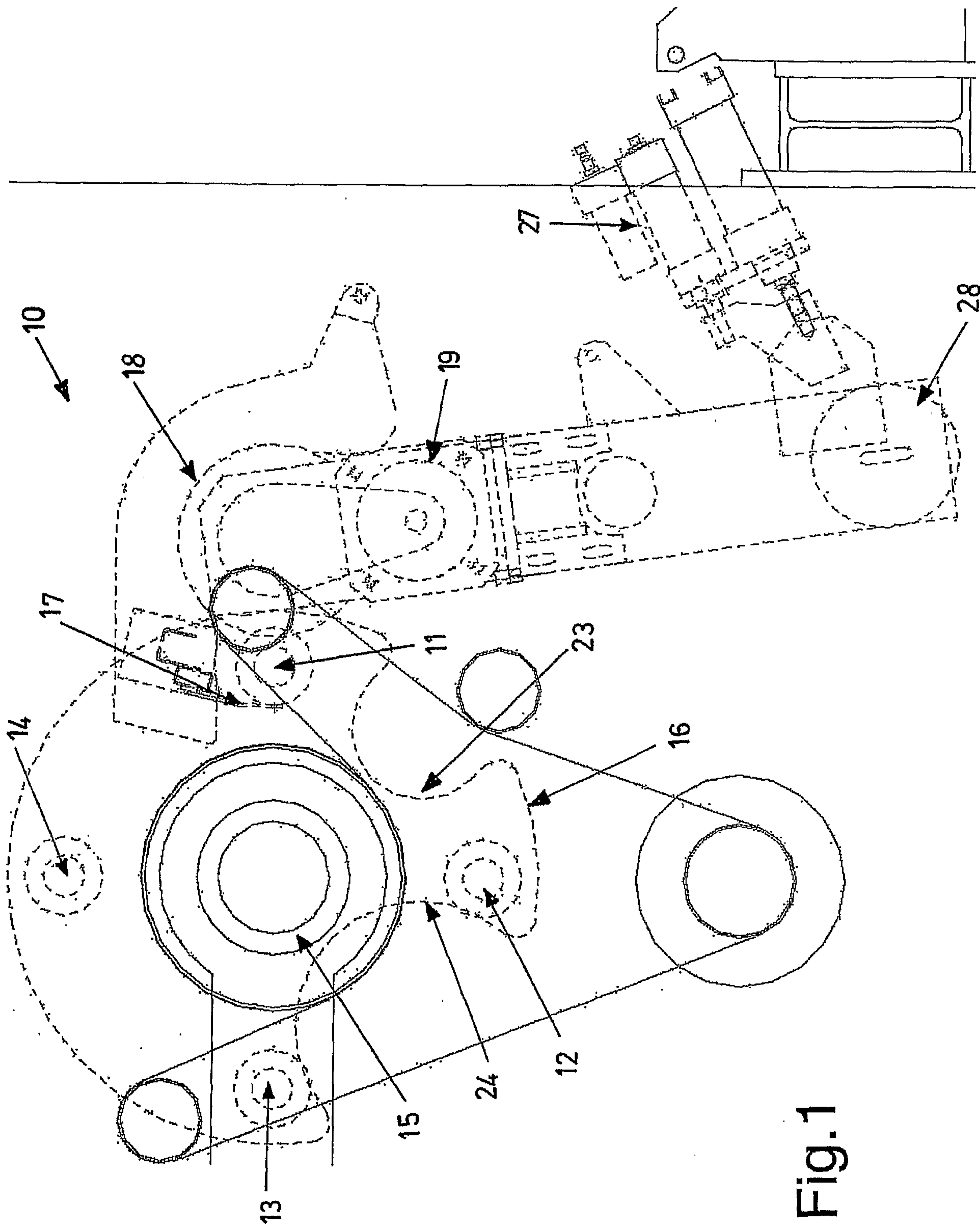

Fig.1

