

No. 652,010.

Patented June 19, 1900.

G. K. WHEELER.
COMBINED LADDER AND ROOF BRACKET AND WINDOW JACK.

(Application filed Oct. 4, 1899.)

(No Model.)

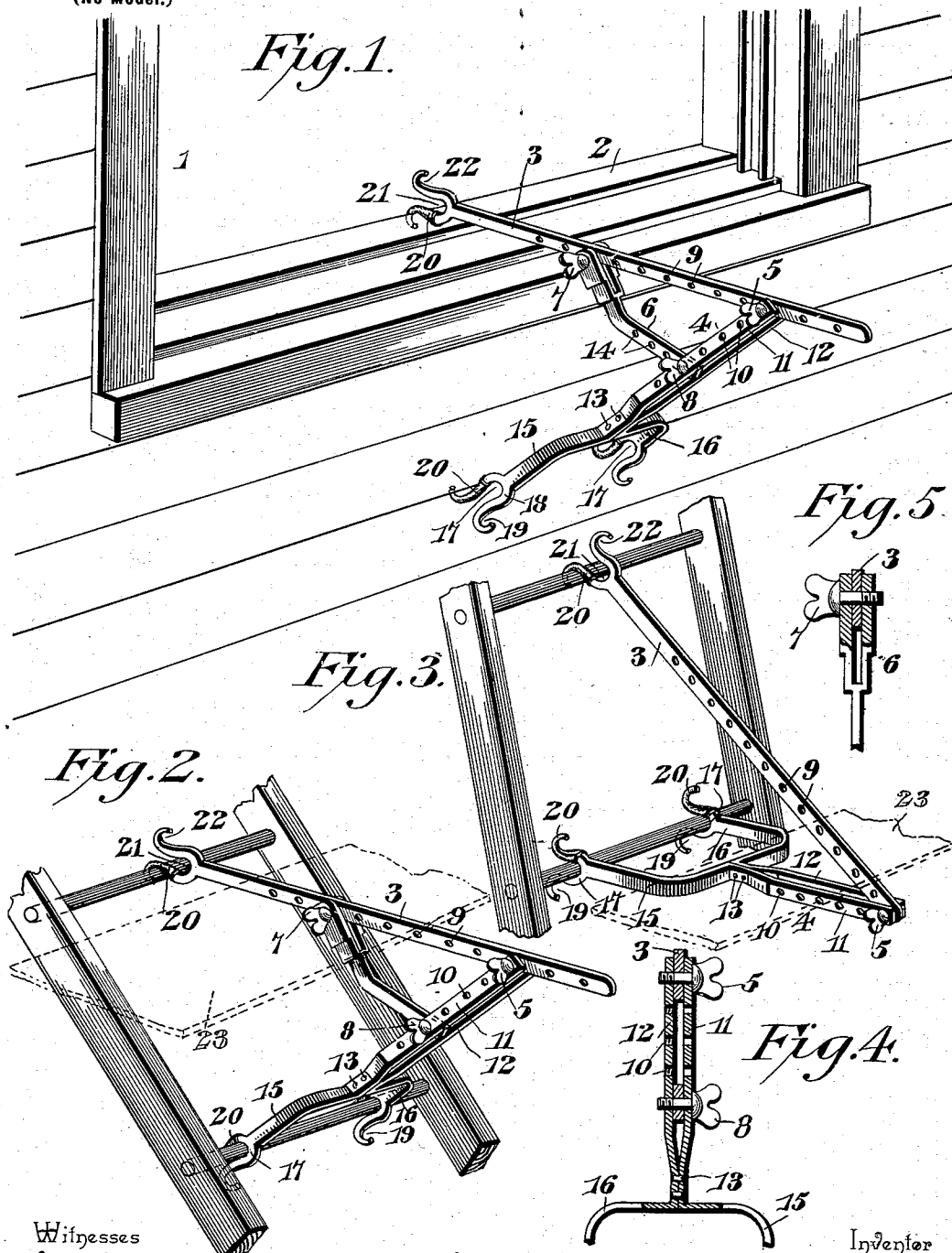

Witnesses
James E. McClathran
Russell G. Julian

Inventor
 By his Attorneys, *George K. Wheeler*

Chas. H. Snow & Co.

UNITED STATES PATENT OFFICE.

GEORGE K. WHEELER, OF HANCOCK, NEW YORK.

COMBINED LADDER AND ROOF BRACKET AND WINDOW-JACK.

SPECIFICATION forming part of Letters Patent No. 652,010, dated June 19, 1900.

Application filed October 4, 1899. Serial No. 732,557. (No model.)

To all whom it may concern:

Be it known that I, GEORGE K. WHEELER, a citizen of the United States, residing at Hancock, in the county of Delaware and State of New York, have invented a new and useful Combined Ladder and Roof Bracket and Window-Jack, of which the following is a specification.

My invention embodies a combined ladder and roof bracket and window-jack, and has for its object the production of a durable, inexpensive, and readily-attachable scaffold-support designed to be self-sustained in various positions upon a building or ladder to support scaffolding.

A further object of the invention is to so construct the bracket that its principal parts may be reversed when necessitated by the accidental derangement of duplicated grappling-hooks and to adapt the bracket for employment in a large variety of positions and for support by variously-disposed structures.

Referring to the drawings, Figure 1 is a perspective view illustrating my device employed as a window-jack. Figs. 2 and 3 are similar views illustrating the application of my device as a ladder-bracket. Fig. 4 is a detail sectional view, on a somewhat-enlarged scale, showing the connection between the member 4 and the contiguous extremities of the member 3 and transverse brace; and Fig. 5 is a similar view illustrating the connection between the transverse brace and the member 3.

Referring to the numerals of reference, indicating corresponding parts in the several views, 1 indicates a portion of an ordinary window-casing, and 2 the sill.

My bracket, as illustrated, consists of a pair of angularly-adjustable supporting members 3 and 4, pivotally connected by a wing-screw 5 and retained in their angularly-adjusted positions by an intermediate transverse brace 6, adjustably connected to the members 3 and 4 by wing-screws 7 and 8. The pivotal connection between the members 3 and 4 is rendered adjustable longitudinally with respect to either or both of the members by a series of apertures 9 and 10 in the members 3 and 4, designed for the reception of the wing-screw 5 when the desired apertures of the members are brought into coincidence at the point

where such pivotal connection is to be established.

It will be noted that the fastenings 7 and 8 at the opposite ends of the transverse brace 6 engage the series of perforations 9 and 10, respectively, with which the fastening 5 also engages, so that the same perforations serve for the adjustment of the angular members and also for the adjustment of the transverse brace.

The supporting member 4 is preferably constructed from two flat strips of steel 11 and 12, riveted together at 13. The end of the member 4 adjacent to the member 3 is thus bifurcated, in effect, by the apposition of the strips 11 and 12 for the reception between them of the member 3 and the contiguous extremity of the transverse brace 6, provided with a series of apertures 14 for the reception of the wing-nut 8, and is bifurcated at its opposite end for the reception of the member 3, upon which, as stated, said brace is adjustable by the engagement of the apertures 9 by the wing-nut 7.

At points adjacent to the rivets 13 the strips 11 and 12 are bent at right angles and are then bent into parallel relation to form a pair of angular legs 15 and 16 at a sufficient distance apart to constitute a broad supporting-base and having terminal recesses 17, formed by the oppositely-curved shanks 18 of oppositely-disposed grappling-hooks 19. In this manner the supporting-arm 4 is provided at the opposite sides or edges of its legs with corresponding parallel grappling-hooks, which are preferably protected by rubber or other tubular or similarly-formed casings 20. The member 3, at its end opposite its connection with the member 4, is provided with a terminal recess 21, formed, like the recesses 17, by the curved shanks of oppositely-disposed grappling-hooks 22, also protected by suitable casings 20, which protect the woodwork from being scarred during the use of my bracket.

It will be observed that the supporting-base of the member 4 is defined by widely-separated pairs of oppositely-disposed hooks arranged in parallel planes and that the pair of hooks at the end of the member 3 is located in a plane midway between and parallel with the pair of hooks first mentioned.

In use, where my bracket is designed for

employment as a window-jack, the members are adjusted at an acute angle and one of the grappling-hooks of the member 3 is hooked under the inner edge of the sill, the adjacent hooks 19 of the member 3 finding a bearing against the side of the house, preferably with their ends in contact with a lap-joint. The scaffolding 23 is thus supported in a horizontal position upon the member 3, and its weight is sustained by the member 4, which in this application of the invention constitutes a brace the upper end of which is retained by the member 3, serving the dual function of a support for the scaffolding and a connector or grapple for the upper end of the brace.

Where the device is employed as a ladder-bracket, the adjustment of the members is necessary in order to compensate for the vertical angle of the ladder and to cause the member 3 to assume a horizontal position when the rungs of the ladder are located respectively within the terminal recesses 17 of the member 4 and are engaged by one of the hooks 22 of the member 3.

In a still further application of the invention—as, for instance, illustrated in Fig. 3—the member 4 constitutes the support for the scaffolding and is located horizontally with a ladder-rung in engagement with the recesses 17 and an upper rung embraced by one of the grappling-hooks 22, the member 3 in this adaptation serving the purpose of a hanger supporting the outer end of the horizontal member 4.

In some instances, perhaps, the transverse brace 6, which, as stated, is designed to rigidly retain the members in their adjusted position, may be omitted, as the wing-screw 5 has threaded connection with one of the strips only, and the strips 11 and 12 may therefore be clamped upon the member 3 with sufficient pressure to retain the angular adjustment of the members against ordinary strain. The same is true with reference to the connection between the bifurcated ends of the brace and the member 3.

It is contemplated in some instances to make the shanks of the grappling-hooks slightly resilient in order that they may be caused to retain the bracket against casual displacement, as when, for instance, the rung of a ladder is snapped into the recesses 17, it being noted that the opening into these recesses, formed between the contiguous faces of the hooks, is slightly constricted.

From the foregoing it will appear that I have produced a simple, inexpensive, and easily-manipulated bracket or jack for the support of scaffolding in various positions and in connection with various structures; but while the present embodiment of my invention ap-

pears at this time to be preferable I desire to reserve to myself the right to effect such changes, variations, and modifications as may be comprehended within the scope of the protection prayed.

What I claim is—

1. A combined bracket and jack comprising a plurality of relatively-adjustable members provided with oppositely-disposed securing-hooks.

2. A combined bracket and jack comprising a member provided at one end with a pair of angular legs terminating respectively in a pair of oppositely-disposed grappling-hooks and an intermediate terminal recess, a second member adjustably, pivotally connected to the first-named member and provided with oppositely-disposed grappling-hooks and an intermediate terminal recess.

3. A combined bracket and jack comprising a member having a broad base formed by a pair of angular legs, each of said legs being provided with a pair of oppositely-disposed hooks opening in the same direction and defining an intermediate terminal recess opening in a direction opposite the hooks, a second member similarly provided with terminal hooks and an intermediate oppositely-disposed recess, and means for effecting an adjustable pivotal connection between the members.

4. A combined bracket and jack comprising a member formed from a pair of metal strips connected at a point intermediate of their length and located in apposition from the connection to one end and bent to form a pair of angular legs beyond the other side of said connection, each of said legs being provided with a pair of oppositely-disposed hooks opening in the same direction and defining an intermediate terminal recess opening in the opposite direction, said pairs of hooks being disposed in parallel planes, a second member embraced between the apposed portions of the first-named member, series of openings in each of the members, a wing-nut engaging coincident apertures in the members to effect their pivotal adjustment, a transverse brace having a bifurcated end embracing one member and having its opposite end apertured and embraced between the apposed portions of the first-named member, and wing-nuts engaging coincident apertures in the members and transverse brace.

In testimony that I claim the foregoing as my own I have hereto affixed my signature in the presence of two witnesses.

GEORGE K. WHEELER.

Witnesses:

EDWARD B. TARBOX, Jr.,

T. J. MCCONNELL.