

(19) World Intellectual Property
Organization
International Bureau



(43) International Publication Date
28 October 2004 (28.10.2004)

PCT

(10) International Publication Number
WO 2004/091732 A2

- (51) International Patent Classification⁷: **A63B**
- (21) International Application Number:
PCT/US2004/010836
- (22) International Filing Date: 8 April 2004 (08.04.2004)
- (25) Filing Language: English
- (26) Publication Language: English
- (30) Priority Data:
10/410,691 9 April 2003 (09.04.2003) US
10/714,388 14 November 2003 (14.11.2003) US

AT, AU, AZ, BA, BB, BG, BR, BW, BY, BZ, CA, CH, CN, CO, CR, CU, CZ, DE, DK, DM, DZ, EC, EE, EG, ES, FI, GB, GD, GE, GH, GM, HR, HU, ID, IL, IN, IS, JP, KE, KG, KP, KR, KZ, LC, LK, LR, LS, LT, LU, LV, MA, MD, MG, MK, MN, MW, MX, MZ, NA, NI, NO, NZ, OM, PG, PH, PL, PT, RO, RU, SC, SD, SE, SG, SK, SL, SY, TJ, TM, TN, TR, TT, TZ, UA, UG, US, UZ, VC, VN, YU, ZA, ZM, ZW.

(84) Designated States (unless otherwise indicated, for every kind of regional protection available): ARIPO (BW, GH, GM, KE, LS, MW, MZ, SD, SL, SZ, TZ, UG, ZM, ZW), Eurasian (AM, AZ, BY, KG, KZ, MD, RU, TJ, TM), European (AT, BE, BG, CH, CY, CZ, DE, DK, EE, ES, FI, FR, GB, GR, HU, IE, IT, LU, MC, NL, PL, PT, RO, SE, SI, SK, TR), OAPI (BF, BJ, CF, CG, CI, CM, GA, GN, GQ, GW, ML, MR, NE, SN, TD, TG).

- (71) Applicant and
- (72) Inventor: HETRICK, Randal, A. [US/US]; 58 West Portal Ave., #108, San Francisco, CA 94127 (US).
- (74) Agent: VOSEN, Steven, R.; 1563 Solano Ave., #206, Berkeley, CA 94707 (US).

Published:
— without international search report and to be republished upon receipt of that report

- (81) Designated States (unless otherwise indicated, for every kind of national protection available): AE, AG, AL, AM,

For two-letter codes and other abbreviations, refer to the "Guidance Notes on Codes and Abbreviations" appearing at the beginning of each regular issue of the PCT Gazette.

(54) Title: EXERCISE DEVICE WITH ADJUSTABLE INELASTIC STRAPS

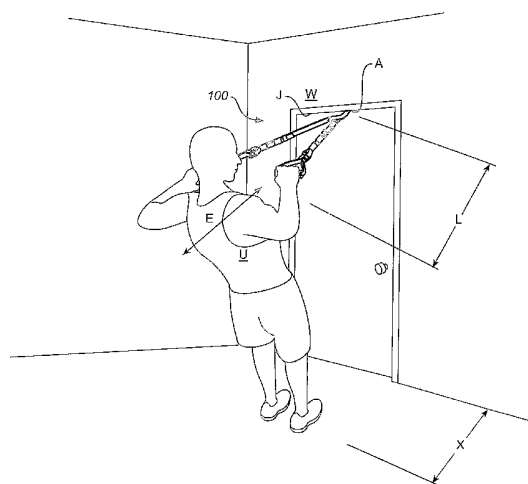

(57) Abstract: An exercise device having many advantageous features is described, including the ability to provide a user selected resistance from nearly zero resistance to the user's full body weight, the ability to easily adjust between exercises and between users, and the ability to balance the device between reconfigurations to provide for ease-of-use. The exercise device is compact and can be removably attached to a door frame. The device includes an inelastic adjustable length member with two arms and a grip at both ends, and a centrally located anchor that provides for a distribution of the length between the arms. Accessory grips that can be used on this or other exercise devices are removably attachable to the integral grip of an exercising device, and provide for gripping by the hands, foot or other body parts.

WO 2004/091732 A2

EXERCISE DEVICE WITH ADJUSTABLE INELASTIC STRAPS

TECHNICAL FIELD

[0001] The present invention relates to exercise devices, and in particular, to an exercise device having an inelastic strap that is easily configurable for use in performing a wide variety of exercises.

BACKGROUND ART

[0002] Resistance exercise devices allow a user to exercise by providing a resistance to the movement of a user's arms, legs, or torso. The term "resistance exercise device" as used herein denotes exercise devices where resistance is provided by working one muscle against another, or by working against the weight of the user, and may include elastic bands to provide an increased resistance force. More specifically, resistance exercise devices, as used herein, do not include a significant or additional weight against which the user exercises. The usefulness of these devices depends, in part, on the ease with which a user can perform different types of exercises, the range or number of exercises that can be performed with the device, and the ease with which different users can adjust the device according to their height, weight, strength, and/or physical limitations. In addition, resistance exercise devices are often lightweight and may be portable.

[0003] Resistance exercise devices having elastic bands typically restrict the motion of a user's arms and/or legs, or the motion between the user and a support structure. Elastic exercise devices can be small, even portable, but have limited usefulness that result from their resistance characteristics, which depend on the length and elasticity of the elastic band. As a result of these characteristics, the elastic bands are useful for a specific length range, thus restricting the diversity of exercises for which it can be used. In addition, it may not be possible for different users to use the same device for the same exercise due to differences in height, weight, or strength between different users. Thus, for an elastic device to be generally useful, such as to provide a complete workout or to allow for different users, a plurality of elastic bands are required that must be easily interchangeable. No known prior art device provides the ease of use necessary to be generally useful across a wide range of exercises.

[0004] Another limitation of elastic resistance exercise devices is that the resistance is inconsistent and increases with increasing displacement, and also tends to snap back when the user decreases his or her effort. While this resistance response provides for a compact design, it is problematic as it does not recreate the resistance encountered by muscles during more natural types of exercising, such as running, swimming, etc. Yet another limitation of elastic devices is

the inability to support a wide range of weight of the user – typically the devices are adapted to support only the resistance provided by the user's muscles. This creates extreme limitations in the exercises that can be performed by any individual elastic device. For this reason, elastic devices must be used over a limited range of stances, further limiting the user's workout.

5 [0005] Another type of resistance exercise device provides an inelastic strap that is attachable to a fixed location such as, for example, a door. These devices may overcome some of the limitations of the elastic devices previously discussed by providing inelastic straps that can be anchored between a door and a door jamb. One of these devices has a fixed length strap attached to a door through a pulley system that allows the user to exercise by moving the arms in opposite
10 directions. Another of these devices has a pair of fixed length straps anchored to a door. Both of these devices are of limited usefulness because of their fixed length and the range of exercises for which they can be used.

[0006] There is a need to provide a resistance exercise device that is easily adjustable so that it can provide a complete workout for any user, including adjustments that allow a wide range of
15 stances and exercises, and that provides resistance to the user's motion in a form that is useful for exercising. In addition, there is a need to provide such a device that is adaptable to be easily portable to enable the device to be mounted to different locations for exercising.

DISCLOSURE OF INVENTION

[0007] The present invention solves the above-identified problems of known resistance exercise
20 devices by providing an inelastic device that is easily adjustable over a large range of lengths, and that can provide resistance ranging from nearly zero to the full body weight of the user. In general, the inelastic device includes elongated inelastic members, such as cords or straps, is attachable to a stationary support, and has grips that allow the user's weight to be transferred to the stationary support. The stationary support may be a structure, including but not limited to a
25 pole, railing, door jamb, or a bracket affixed to a wall or other structure, or may be a naturally occurring object, such as a tree. In one embodiment, the inelastic device is easily adjustable over a large range of lengths, and that can provide resistance ranging from nearly zero to the full body weight of the user. The present invention provides for a variety of interchangeable grips of different types and for mounting to different types of stationary supports.

30 [0008] In one embodiment, the present invention provides an exercise device having an elongated member with a grip at both ends and an anchor between the grips for attaching to a

structure, where the length of the elongated member is adjustable and where the anchor provides for the elongated member to center on the anchor when the grips are pulled. The device therefore allows a user to easily vary the length of the device and to balance according to the forces applied to the grips. In particular, by positioning the grips equidistant to the anchor while
5 pulling on the grips, the device effectively centers the elongated member on the anchor. Thus, for a user that positions her feet equidistant from the anchor and pulls back to support her weight on the device, the lengths of the two arms of the elongated member are distributed equally, thus creating a balanced device.

[0009] As used herein, the noun "grip" encompasses any device that is interlockable with part of
10 the human body, that is it can be connected in such a way that a person can transfer a force to the grip, preferably a force equal to some or all of the person's weight, and the verb "grip," when used herein, refers to the action of interlocking the device and a body part. When used in an exercise device, a grip is attached to other elements that permit the force to be transferred to another object, including but not limited to a stationary support, a device that can store or release
15 energy, such as an elastic cord or a spring, or another body part. Grips include devices that can be surrounded by a body part, for example flexible loop or a hook, or that a body part can surround, for example an elongated member that can fit within the grasp of the hand. In this context, a member that can be gripped, or is grippable, is one that can surround a body part or can be surrounded by a body part, and has a size and configuration that permits the transfer of
20 forces from the user to the grip.

[0010] In one embodiment, the present invention provides an exercise device having an elongated member with a grip at both ends and an anchor between the grips for attaching to a stationary support, where the length of the elongated member is adjustable and where the anchor provides for the elongated member to center on the anchor when the grips are pulled. The device
25 therefore allows a user to easily vary the length of the device and to balance according to the forces applied to the grips. In particular, by positioning the grips equidistant to the anchor while pulling on the grips, the device effectively centers the elongated member on the anchor. Thus, for a user that positions her feet equidistant from the anchor and pulls back to support her weight on the device, the lengths of the two arms of the elongated member are distributed equally, thus
30 creating a balanced device.

[0011] It is one aspect of the present invention to provide an adjustable, inelastic exercise device comprising an elongated member having a pair of ends separated by a length and a mechanism

for adjusting the length. The pair of ends includes a first end having a first grip and a second end having a second grip. The device also includes an anchor having a first portion for mounting the device to a stationary support and a second portion to support the elongated member at a position along the length when both of the grips are pulled in a direction away from the anchor. The support and elongated member interact to provide frictional restraint with respect to the anchor as a function of the force applied to each of the pulled grips. Thus in one embodiment, the frictional restraint restrains the elongated member with the grips equidistant from the anchor when the sum of the forces is increased while the user positions each of the grips a distance of one half of the length from the anchor.

[0012] It is another aspect of the present invention to provide an adjustable, inelastic exercise device comprising an elongated member including at least one strap, a pair of ends separated by a length, and a pair of cam buckles including a first cam buckle adjacent to one of the pair of ends and a second cam buckle adjacent to the other of the pair of ends. The length of the elongated member is adjustable according to the length of strap through the cam buckles. The device also includes an anchor having a first portion for mounting the device to a stationary support and a second portion to support the elongated member at a position along the length when both of the grips are pulled in a direction away from the anchor. The support and elongated member interact to provide frictional restraint with respect to the anchor as a function of the force applied to each of the pulled grips. Thus in one embodiment, the frictional restraint restrains the elongated member with the grips equidistant from the anchor when the sum of the forces is increased while the user positions each of the grips a distance of one half of the length from the anchor.

[0013] It is yet another aspect of the present invention to provide an adjustable, inelastic exercise device comprising an elongated member having a pair of ends separated by a length and a mechanism for adjusting the length. The pair of ends includes a first end having a first grip and a second end having a second grip. The device also includes an anchor having a first portion for mounting the device to a stationary support and a second portion to support the elongated member at a position along the length when both of the grips are pulled in a direction away from the anchor. The support and elongated member interact to provide frictional restraint with respect to the anchor as a function of the force applied to each of the pulled grips. Thus in one embodiment, the frictional restraint restrains the elongated member with the grips equidistant from the anchor when the sum of the forces is increased while the user positions each of the grips

a distance of one half of the length from the anchor.

5 [0014] It is one aspect of the present invention to provide a portable exercise apparatus comprising a resistance exercise device with at least one integral grip that is removably coupled to an accessory grip. The accessory grip allows the exercise device to be used for a greater range of exercises and allows for additional muscles to be exercised. In one embodiment, the integral
10 grips are rigid elongated members, such a tube, having an outer circumference, and the accessory grip has a grip attachment portion including at least one strap having a length greater than the outer circumference and includes a fastener to secure the grip attachment portion about the integral grip. In one embodiment, the accessory grip includes a loop adapted for accepting a heel
15 of a user. In a second embodiment, the accessory grip includes one or more loops each adapted for accepting at least one finger of a user. In a third embodiment, the accessory grip includes a plurality of cords adapted for gripping, in any combination, by a hand of a user. In yet another embodiment, a bracket is provided to support the exercise device to a wall.

20 [0015] It is yet another aspect of the present invention to provide an accessory for attaching to an integral grip of a resistance exercise device comprising an accessory grip coupled to an attachment portion that is removably attachable to the integral grip, such that the exercise apparatus provides resistance through the accessory grip. In one embodiment, the integral grip is a rigid elongated member having an outer circumference, and the attachment portion includes at least one strap having a length greater than the outer circumference of the rigid elongated
25 member and includes a fastener to secure the strap about the rigid elongated member.

[0016] It is another aspect of the present invention to provide a grip for an exercise device comprising a plurality of cords each having a grip portion with a length greater than 4 inches (0.1 m) and a diameter of from 1/4 inch (6 mm) to approximately 1 inch (25 mm), and a joint mutually connecting the plurality of cords and connected to the exercise device. The plurality of
30 cords are sufficiently flexible to adjacently arrange two or more of the grip portions of the plurality of cords, such that a user can grip two or more of the grip portions. In one embodiment the cord ends not attached to the joint are themselves joined.

[0017] It is one aspect of the present invention to provide a device for anchoring an exercise device to a wall, where the exercise device includes a pair of grips and an anchor having a strap with an enlarged end. The device includes a bracket having a first portion to affix to the wall and
35 a second portion having an opening and spaced apart from an affixed wall. The opening is

adapted to accept the strap of the anchor, the spacing between the second portion and an affixed wall is sufficient to accept the enlarged portion between the accepted strap and the affixed stationary support, and the opening is sufficiently small to prevent the enlarged portion from passing through the opening. The exercise device is thus removably supportable by the opening
5 of the bracket.

[0018] One aspect of the present invention is to provide a substantially inelastic exercise device that can be anchored to a structure and that has an adjustable length that is self-centering about an anchor point upon pulling by the user.

[0019] Another aspect of the present invention is to provide an exercise device that can be
10 anchored to a stationary support and exert a substantially inelastic resistance to the motion of a user through a pair of arms, each with a grip, having an adjustable length that centers about the anchor when pulled by the user.

[0020] It is another aspect of the present invention to provide an adjustable and essentially self-centering exercise device that can support up to the full weight of the user.

[0021] It is yet another aspect of the present invention to provide a portable exercise device that
15 can be easily attachable to a stationary support and that can provide a complete workout of user determined intensity, resistance, and effort.

[0022] These features together with the various ancillary provisions and features which will become apparent to those skilled in the art from the following detailed description, are attained
20 by the exercise device of the present invention, preferred embodiments thereof being shown with reference to the accompanying drawings, by way of example only, wherein:

BRIEF DESCRIPTION OF DRAWINGS

[0023] FIG. 1 is a schematic front view of one embodiment of an exercise device of the present invention as anchored between a door and door jamb;

[0024] FIG. 2 is a partial schematic sectional view 2-2 of FIG. 1 showing the exercise device
25 anchored between a door and door jamb;

[0025] FIG. 3 is illustrative of a user performing a high row exercise with the exercise embodiment of FIG. 1;

[0026] FIG. 4 is a perspective view of another embodiment of the exercise device of the present invention;

[0027] FIGS. 5A and 5B are views of the anchor portion of the exercise device of FIG. 4, where FIG. 5A is a perspective view, and FIG. 5B is sectional view 5B-5B;

5 [0028] FIG. 6 is a schematic top view of the elongated member of the embodiment shown in FIG. 4 having two lengthening mechanisms and two hand grips;

[0029] FIG. 7 is a perspective view showing details of the grip and the lengthening mechanism of the embodiment of FIG. 4;

[0030] FIG. 8 is a sectional view 8-8 of FIG. 7 showing the hand grip;

10 [0031] FIG. 9A is a perspective view showing details of the slack sleeves of the embodiment of FIG. 4;

[0032] FIG. 9B is a sectional view 9B-9B of FIG. 9A showing details of the cam buckle and attachment of the slack sleeves to the cam buckle;

15 [0033] FIG. 10 is a schematic top view of an alternative elongated member embodiment having one lengthening mechanism and two finger grips;

[0034] FIG. 11 is schematic sectional view 11-11 of the finger grip embodiment of FIG. 10;

20 [0035] FIGS. 12A-12D are schematic drawings illustrating the lengthening and centering of the exercise device of the present invention, where FIG. 12A is the initial configuration, FIG. 12B illustrates lengthening the elongated member, further illustrated in FIGS. 12B' and 12B'', FIG. 12C shows the application of force to the shorter leg of the elongated member, and FIG. 12D shows the application of force to the grips during an exercise;

25 [0036] FIGS. 13A-13C are schematic drawings illustrating the lengthening and adjusting of the exercise device of the present invention having differing arm lengths, where FIG. 13A is the initial configuration, FIG. 13B shows the application of force to one of the pair of legs, and FIG. 13C shows the application of force to the grips during an exercise;

[0037] FIG. 14A is an alternate embodiment anchor that can be used for attaching the exercise device to a pole or railing, and FIG. 14B is a exercise device of the present invention anchored to

a pole using the alternative anchoring embodiment of FIG. 14A;

[0038] FIGS. 15A-15I illustrate poses of a user using the inventive exercise device to performing exercises, where FIG. 15A is a reverse combination crunch, FIG. 15B is a single leg L-squat, FIG. 15C is a gymnast dip, FIG. 15D is a kneeling combination crunch, FIG. 15E is a lying leg curl, FIG. 15F is a hip lift, FIG. 15G is a front shoulder raise, FIG. 15H is a crunch, and FIG. 15I is a triceps extension;

[0039] FIGS. 16A and 16B illustrate the device of the present invention for doing one handed exercises, where FIG. 16A shows interlocking the handles for one handed exercises, and FIG. 16B illustrates the use of the exercise device in performing a one arm high row exercise;

10 [0040] FIGS. 17A and 17B show a foot grip accessory of the present invention as attached to a grip of an exercise device, where FIG. 17A illustrates the foot grip accessory gripped by the user's toes, and FIG. 17B illustrates a pair of foot grip accessories with one accessory on each of the pair of grips of an exercise device and grasped by one of the user's heels;

[0041] FIGS. 18A, 18B, 18C and 18D show one embodiment of the foot grip accessory of FIGS. 15A-15I, where FIG. 18A is a perspective view of the foot grip accessory, FIG. 18B is a bottom view of the foot grip accessory, FIG. 18C is a side view of part of one of the grip attachment portions, and FIG. 18D is a top view of part of one of the grip accessory attachment portions;

[0042] FIGS. 19A, 19B, and 19C show a finger grip accessory of the present invention as attached to a grip of an exercise device, where FIG. 19A illustrates the one finger placed through one of the loops, FIG. 19B illustrates one finger be placed through each of the two loops, and FIG. 19C shows two fingers placed through each of the two loops;

[0043] FIGS. 20A, 20B, and 20C show one embodiment of the finger grip accessory of FIGS. 19A-C, where FIG. 20A is a perspective view of the finger grip accessory, FIG. 20B is a top view 20B-20B of the finger grip accessory, and FIG. 20C is a sectional side view 20C-20C of the finger grip accessory;

[0044] FIGS. 21A, 21B, and 21C shown a grip accessory of the present invention as attached to a grip of an exercise device, where FIG. 21A illustrates a hand gripping three cords, FIG. 21B illustrates the hand gripping two cords, and FIG. 21C illustrates the hand gripping one cord;

[0045] FIGS. 22A, 22B, 22C, and 22D show one embodiment of the grip accessory of FIGS.

21A-C, where FIG. 21A is a perspective view of the grip accessory, FIG. 21B is a top view of the grip accessory, FIG. 21C is a bottom view of the grip accessory, and FIG. 21D is sectional side view 21D-21D of FIG. 21C;

[0046] FIG. 23 shows another alternative embodiment anchor;

5 [0047] FIG. 24 illustrates the use of the anchor of FIG. 23 to anchor an exercise device to a tree; and

[0048] FIGS. 25 and 26 shows a bracket for securing an exercise device of the present invention by an enlarged first end of an anchor, where FIG. 25 is a perspective front view of a bracket for mounting an exercise device, and FIG. 26 illustrates the use of the bracket to anchor the exercise
10 device.

[0049] Reference symbols are used in the Figures to indicate certain components, aspects or features shown therein, with reference symbols common to more than one Figure indicating like components, aspects or features shown therein.

MODES FOR CARRYING OUT THE INVENTION

15 [0050] In general, the present invention provides an inelastic exercise device that is supported by, or that can be easily attached to, a supporting structure, and that allows a user to perform a large number of exercises by easily adjusting the length of the device and thereafter balancing the device as the user transfers his weight to the device. Several of the features of the present invention will now be illustrated with reference to FIGS. 1-3, which show the set-up and use of
20 the device of the present invention, and which is not meant to limit the scope of the present invention. FIG. 1 is a schematic front view of one embodiment of exercise device **100** that is anchored at a point **A** between a door **D** and door jamb **J**. FIG. 2 is a partial sectional view 2-2 of FIG. 1 taken through door **D** and showing exercise device **100** in profile, and FIG. 3 is illustrative of a user **U** exercising with the exercise device of FIG. 1.

25 [0051] Exercise device **100** includes an anchor **110** and an elongated member **120** having a pair of arms **122**, indicated as a first arm **122a** and a second arm **122b**, on either side of the anchor, as shown schematically in FIGS. 1 and 2. A pair of grips **123** is provided, with one positioned at the end of each arm **122**, specifically first arm **122a** has a first grip **123a**, and second arm **122b** has a second grip **123b**. Elongated member **120** is substantially inelastic and flexible with a
30 length **S** between the pair of grips **123**, and has a portion **129** that can be a strap or cord or other

inelastic, flexible member, and a lengthening mechanism **135** that provides for increasing or decreasing the length **S**, as indicated by double arrows ΔS .

[0052] Anchor **110** is used to provide a fixed anchor point for exercise device **100** and to support a user's weight as it is applied to arms **122** as indicated by an arrow **F** in FIG. 2 and as shown in FIG. 3. As shown in FIG. 2, anchor **110** is adapted for positioning exercise device **100** in a door and providing support to elongated member **120** by having an enlarged portion **111**, a portion **113** that can be strap or cord, and an approximately triangular shaped loop **115** for slidably supporting the elongated member. With enlarged portion **111** on the opposite side of door **D** from elongated member **120**, anchor **110** supports the weight of a user as grips **123** are pulled. In addition, anchor **110** provides for positioning the relative length of arms **122** as shown in FIG. 1 by double arrow **C**. Thus, the total length of elongated member **120** and distribution of that length between each of arms **122** can be easily adjusted through the lengthening mechanism **135** and by pulling the ends of the elongated member. FIG. 2 shows arms **122** each having a length **L**.

[0053] When supported by a structure, such as door **D** (shown in FIGS. 1-3) or a railing, pole or other support member (not shown) the inventive exercise device provides a pair of grips for a user to exercise against her weight according the user's position relative to the device, and provides for easily adjusting the length of the device. As described below, the inventive device can be used to exercise in any one of a large number of orientations according the selected adjustable length and according to where and how the user stands relative to the exercise device. In general, a user sets the exercise device to a desired length, positions herself on the ground near the exercise device, supports a portion of her body weight from the exercise device by her hands or feet, and exercised by moving her body with her weight supported by the ground and the exercise device. Examples of support on the ground and exercise device include, but are not limited to, standing on one or both legs, lying on the stomach or the back, kneeling, or by having the hands on the ground, and having the exercise device support ones weight by the hands or feet, as appropriate.

[0054] With reference to FIG. 3, a user **U** is shown in one of the many exercise positions, in particular a high row exercise, gripping the pair of grips **123** with the user's hands and having the user's feet placed a horizontal distance **X** from anchor point **A**. When anchored to a door, it is preferred that anchor point **A** is on the inwards side of the door (that is, that the door open away from user **U**) so that jamb **J** can support the user's weight. The user **U** is shown leaning away

from anchor point **A** and supporting a fraction of his or her weight through device **100**. It is apparent that user **U** can vary the amount of supported weight, and thus the resistance of exercise device **100**, by adjustment of his or her stance relative to anchor point **A** (distance **X**) and the length of arms **122** (length **L**). The user **U** of FIG. 3 performs a high row exercise by moving his body in a direction **E** towards and away from anchor point **A**. Note that other exercises are also possible with the user in this position by the user moving in other directions with the user's weight supported by the ground and exercise device **100**.

[0055] Several embodiments of the present invention will now be described with reference to the drawings. These embodiments are meant to illustrate the invention, and are not meant to limit the scope of the invention.

[0056] FIGS. 4-9 are various views of another embodiment of an exercise device **400** of the present invention. Referring first to FIG. 4, a perspective view of exercise device **400** is shown as including an anchor **410** and an elongated member **420**. Anchor **410** includes an inelastic, flexible strap **413** having an enlarged first end **411** that is wider than the strap, and a second end that forms a loop **415**. Elongated member **420** passes through loop **415**, defining a pair of arms **422**, indicated as arm **422a** and **422b**. Each arm **422** has a respective end **421**, shown as end **421a** and **421b**, each with one of a pair of grips **423**, shown as grip **423a** and **423b**. Elongated member **420** also includes a pair of lengthening devices or buckles **435**, shown as buckle **435a** and **435b**, at either end of a central strap **429** that provides for the adjustment of the length of the elongated member. Specifically, strap **429** has a pair of ends **431**, indicated as **431a** and **431b**, that pass through buckle **435a** and **435b**, respectively. As described subsequently, elongated member **420** is substantially inelastic, with the length of the elongated member being adjustable through the action of one or both of the pair of buckles **435**.

[0057] FIGS. 4, 5A and 5B present several views of anchor **410**, where FIG. 5A is a perspective view of the anchor and FIG. 5B is a sectional view 5B-5B of the anchor. As noted previously, anchor **410** includes an inelastic, flexible strap **413**. It is preferred that the majority of lengths of anchor **410** and elongated member **420** are formed of materials that include, but are not limited, to straps of a webbing of a natural or synthetic material having a strength sufficient to support the weight of a device user. Preferred webbings include, but are not limited to, webbings made of nylon, polypropylene or other polymeric fibers. It is understood that a single length of flexible material according to the present invention can alternatively comprise two or more pieces that are stitched, glued, or otherwise attached to one another. It is preferred that the length

of anchor **410** is from 6 to 18 inches (0.15 – 0.45 m), or more preferably, approximately 12 inches (0.3 m).

[0058] Strap **413** has an enlarged first end **411** that is wider than the strap, and a second end **417** that is attached to the strap so as to form a loop **415**. As shown in FIG. 5B, strap **413** has an end **502** forming the core of first end **411**. Since one of the intended uses of anchor **410** is to anchor exercise device **400** between a door and jamb, it is preferable that the end **411** include materials that are soft enough to prevent damage to a wood door or door frame, yet be sturdy enough to support the weight of a user. One embodiment that is soft yet sturdy is shown in FIG. 5B. Specifically, strap end **502** is partially surrounded by a recessed enclosure **505** and a pillow **507** that covers the strap end and the enclosure. Strap end **502** can further be held within end **411** by gluing and stitching the strap end to enclosure **505** and pillow **507**, and by closing the pillow with one or more stitches **509**. Strap **413** passes into first end **411** through a slot **504** in enclosure **505** and through slot **501** in pillow **507**. In a preferred embodiment, first end **411** is approximately 3.5 inches (90 mm) by 2.5 inches (63 mm) and is oriented approximately perpendicular to strap **413**. It is also preferred that enclosure **505** is formed of a high-density, closed cell foam, and that pillow **507** is formed from a felt, and includes stitches **503**. Alternatively, a second strap or piece of another material could be sewn, glued or otherwise attached to the end of strap **413** to form end **502**. In another alternative embodiment, enclosure **505** can include another rigid member, such as a metal or hard plastic plate, to increase the rigidity of strap end **411**.

[0059] Elongated member **420** is shown in greater detail in FIGS. 6-9, where FIG. 6 is a schematic top view of the elongated member, FIG. 7 is a perspective view of one of the pair of grips **421** and the corresponding one of the pair of buckles **435**, FIG. 8 is a sectional view 8-8 of one of the pair of grips **421**, and FIG. 9A is a perspective view showing details of one of the pair of buckles and the adjoining strap **429**. As shown in FIG. 6, the elongated member **420** has length **S**, and includes two inelastic strap portions **427**, indicated as **427a** and **427b**, strap **429** and the pair of buckles **435** for adjusting the length **S**. The portion of elongated member **420** from each end to the nearest buckle has a fixed length - that is, each of the two portions from one of the pair of ends **421** to the corresponding one of the pair of buckles **435** has a fixed length. It is preferred that the length **S** is adjustable over a length that allows for a wide range of exercises. Preferably, length **S** can be varied in length from approximately 6 feet (1.8 m) to 12 feet (3.6 m). Also preferably, elongated member **420** has a width of approximately 1.5 inches (38 mm). It is

also preferred that the surface finish of strap 429 and loop 415 allows the user to easily slide the elongated member 420 along anchor 420, while providing enough friction so that there can be some mismatch in forces on the two ends 421 without the elongated member sliding through the anchor while a user is exercising.

5 [0060] The details of one of the pair of ends 421, including strap 429 to grip 423, and including buckle 435 are shown in FIGS. 7, 9A and 9B. Buckle 435 is a cam buckle, the design and use of which are well known in the art. Buckle 435 is attached to strap 427, and thus the length of each of end 421 is not adjustable. Buckle 435 is also slidably accepts and grips strap 429, allowing for adjustment of the length S.

10 [0061] Buckle 435 has a frame 709, a first strap bar 705, a second strap bar 707, and a user movable cam 711. Strap 427 has one end that loops about first strap bar 705, and a second, free end 431 that loops about second strap bar 707. This loop of strap 427 about bar 705 is preferably secured by stitches 703. Alternatively, strap 427 can be secured to bar 705 through a second member, such as another looped strap or a plastic or metal piece that loops about bar 705 and provides a location to attach strap 427. In addition, it is understood that the use of stitches as described herein to fasten strap portions can also be accomplished through the use of other methods of fastening, such as glue or by melting strap portions together.

[0062] Cam 711 is spring loaded such that it normally restrains a strap 429, and that under the action of a user, such as by pushing or pulling the cam, the cam is moved to allow the strap to move. The distance between cam 711 and bar 707 is adjusted by the user and a spring within buckle 435 by pushing on cam 711, allowing strap 429 to slide between cam 711 and bar 707. Thus, the length S can be adjusted by the user actuating cam 711 of buckle 435.

[0063] Grip 423 is shown in greater detail in the sectional view of FIG. 8. Grip 423 has a generally tubular shape, with an outer cover 801 and an inner cylindrical tubular portion 803. Cover 801 has a length and outer diameter to allow a hand to easily grab grip 423, and is formed from a material that permits a user to hold it while exercising. A preferred material for cover 801 is a high-density foam. Portion 803 provides the strength of grip 423 and can be formed from a length and diameter of plastic or other rigid material to match the size of cover 801 and to provide space for a loop 425 to pass through the center of portion 803. Portion 803 is preferably formed from a rigid and light material, such as PVC tubing.

[0064] One of the pair of free ends 431 is shown in greater detail in FIG. 9A. Each end 431 is

preferably folded back, and is held in place, for example by a stitch **901**, to form an easily manipulated end. Elongated member **420** also includes several sleeves, shown as sleeves **903**, **905a** and **905b** that twice surrounds strap **429** to prevent ends **431** from moving about.

Specifically, sleeves **903** and **905** are placed between buckles **435**, ends **431** and strap **429**. Thus sleeves **903** and **905** restrain the portion of strap **429** from a buckle **435** to the corresponding end **431** from moving about as exercise device **420** is moved. As shown in FIG. 9A, sleeve **903** is affixed near end **431**, while sleeves **905** can be slid along the length of strap **429**. FIG. 9B is a sectional view 9B-9B of FIG. 9A showing details of the cam buckle and attachment of sleeve **905b**. In particular, FIG. 9B shows a bar **907** that spans buckle **435** and a strap **909** that is attached both the bar and to sleeve **905b**. Strap **909** keeps sleeve **905b** from sliding too far down strap **429** during adjustment of the length of the exercise device. It is preferred that sleeves **905b** are elastic so that they can easily move and hold together the portions of strap **429**.

[0065] While exercise device **400** has been described with respect to a particular embodiment, there are many alternative embodiments that are within the scope of the present invention. Thus, for example, there are many embodiments that provide for an adjustable length, substantially inelastic, strap-like member that has an easily adjustable length and balance of the two sides of the strap-like member about the anchor. One alternative embodiment is shown in FIGS. 10 and 11, where FIG. 10 is a schematic top view of an alternative elongated member **820** having one cam buckle **425** as a lengthening device, and two finger grips **1001**, and FIG. 11 is a sectional view of alternative finger grips. The use of one buckle **435** provides a lighter exercise device **400**, but results in a smaller useful range of lengths for elongated member **1020**. Finger grips **4001** include four holes **4101** for the user's fingers, and allows for exercise of one or more finger muscles. Modified finger grips can alternatively be provided as an "add-on" modification to elongated member **420**, allowing the user to switch between finger and hand grips. A variety of other add-on grip accessories, not shown, can be used with exercise device **400**, including but not limited to a cord grip for forearm development, a heel cup accessory for securing the feet to the handles for leg development exercises.

[0066] The balancing and lengthening aspects of the present invention are illustrated in FIGS. 12A-12D, where FIG. 12A is an initial configuration, FIG. 12B illustrates lengthening the elongated member **420**, further illustrated in FIGS. 12B' and 12B'', FIG. 12C shows the application of force to the shorter leg of the elongated member, and FIG. 12D shows the application of force to the grips during an exercise. For illustrative purposes, FIG. 12A is

assumed to be an initial configuration of an anchored device, and it is assumed that the user wishes to increase the length **S** while keeping the pair of arms **422** the same length (approximately one half of **S**). First, the user actuates one or both buckles **435**. FIG. 12B schematically shows the result of actuating buckle **435a** and elongating leg **422a** as indicated by the arrows on that figure. FIG. 12B' shows the user **U** pushing cam **711** and grabbing end **431**, and FIG. 12B'' shows the user pulling end **431** away from the cam, as indicated by the arrow, to shorten the device.

[0067] The user then preferentially pulls on the shorter leg **422b** as indicated by force vector **F1** of FIG. 12C. With both of the pair of legs **422** having approximately the same, longer length the user can then exercise, as indicated in FIG. 12D, by applying equal forces **F2** to each handle grip. In practice, it is not necessary for the two forces of FIG. 12D to be equal, as the application of force to legs **422** away from anchor **410** increases the friction between elongated member **420** and the anchor, allowing the lengths to not change, even under some mismatch of applied forces. Alternatively, exercise device can be adjusted to provide shorter legs **422** by pulling on end **431** to shorten the length **S**.

[0068] In addition to being equally balanced between the two arms, it is possible to use the inventive device to provide differing arm lengths for exercising. FIGS. 13A-13C illustrate the lengthening and adjusting of exercise device **400** having differing lengths of arms **422**, where FIG. 13A is an initial configuration, FIG. 13B shows the application of force to one of the pair of arms **422**, and FIG. 13C shows the application of force to the grips during an exercise. For illustrate purposes, FIG. 13A is assumed to be an initial configuration of an anchored device, and it assumed that the user wishes to adjust the length of arms **422** to different lengths. First, the user preferentially pulls on the shorter leg **422b** as indicated by force vector **F1** of FIG. 13B. The user can then exercise, as indicated by the equal forces **F2** of FIG. 13C. In practice, it is not necessary for the two forces of FIG. 13C to be equal, since as illustrated in FIG. 12, as the application of force to legs **422** away from anchor **410** increases the friction between elongated member **420** and the anchor also increases. This limits the possibility that the arm lengths will change, even under some mismatch of applied forces. The adjustment of arms **422** to different lengths can be combined with the lengthening or shortening of the length **S** by actuating one or both of buckles **435**.

[0069] Various mechanisms for providing a fixed anchor point are within the scope of the present invention. Thus, it is within the scope of the present invention to provide an exercise

device that can be anchored in a door, about a pole, railing or stanchion, from a hook installed in a wall, or can be permanently affixed to a wall or exercise structure, for example. FIG. 14A is an alternate embodiment anchor **1400** that can be used for attaching the exercise device to a pole or railing, and FIG. 14B is an exercise device of the present invention anchored to a pole using the
5 alternative anchoring embodiment of FIG. 14A.

[0070] FIG. 14A shows alternative embodiment anchor **1410** which includes an adjustable loop **1419** and an anchor loop **1415**. As described subsequently, anchor **1410** is an alternative anchor, and can, for example, presents anchor loop **1415** for accepting strap **429** of elongate member **420** to form an exercise **1400**. Adjustable loop **1419** is formed from a flexible strap **1411** and a cam
10 buckle **1412** as follows. Cam buckle **1412** can be, for example, cam buckle **435** shown in detail in FIG. 9B. Flexible strap **1411** has a free, first end **1414** that is threaded through the cam portion of cam buckle **1412**, for example by threading the strap between the second strap bar **707** and movable cam **711** of cam buckle **435**. Flexible strap also has a second end **1418** that is attached to cam buckle **1412**, for example, by looping the second end about first strap bar **705** of
15 cam buckle **435** and providing a stitching **1416** through a double thickness of strap **1411**. Strap **1411** thus threaded through buckle **1412** has forms an adjustable loop **1419** that can be increased or decreased in size by actuating cam buckle **1412** to release strap **1411**, moving the strap through the cam buckle, and releasing the cam. End **1414** is held against strap **1411** by a slack sleeve **1413**. An anchor loop **1415** is attached to strap **1411** by a stitching **1417**.

20 [0071] It is preferred that the majority of lengths of anchor **1410** are formed of materials that include, but are not limited, to straps of a webbing of a natural or synthetic material having a strength sufficient to support the weight of a device user. Preferred webbings include, but are not limited to, webbings made of nylon, polypropylene or other polymeric fibers. It is understood that a single length of flexible material according to the present invention can
25 alternatively comprise two or more pieces that are stitched, glued, or otherwise attached to one another.

[0072] FIG. 14B shows exercise device **1400** formed from anchor **1410** and elongated member **420**. Anchor loop **1413** of anchor **1410** is tightened about a pole **P**. Adjustable loop **1411** may be placed over the top of the pole and tightened using cam buckle **1412**. Alternatively, strap
30 **1411** can unthreaded from cam buckle **1412**, wrapped about pole **P**, and then threaded through the cam buckle and tightened. In either case, end **1414** is the pulled through cam buckle **1412** and adjustable loop **1419** is tightened about pole **P** with sufficient force to allow exercise device

1400 to support a users weight.

[0073] In addition to being attached to a pole, anchor 1410 can be tensioned to support exercise device 1400 about a railing, post, or other member. Alternately, the anchor can be attached to a carabineer that is fixed to a wall or other structure.

5 [0074] FIG. 23 shows an anchor 2300 including a flexible strap 2301 with a first end 2305 having a loop 2307 held in place with stitching 2311 and a second end 2303 having a carabineer 2304 held in place by stitching 2309, and FIG. 24 illustrates the use of anchor 2300 to anchor the elongated member 120 of the exercise device to a tree. It is preferred that the majority of lengths of strap 2301 are formed of materials that include, but are not limited, to straps of a webbing of a
10 natural or synthetic material having a strength sufficient to support the weight of a device user. Preferred webbings include, but are not limited to, webbings made of nylon, polypropylene or other polymeric fibers. FIG. 24 shows an exercise device 2400 formed from anchor 2300 and elongated member 420. Strap 2301 is be wrapped about a tree with carabineer 2304 accepting the strap. Loop 2307 accepts strap 429, allowing the user to exercise against a tree or other
15 object small enough for strap 2301 to be wrapped about.

[0075] FIGS. 25 and 26 shows a bracket 2500 for securing exercise device 400 by enlarged first end 411 of anchor 410, where FIG. 25 is a perspective front view of the bracket, and FIG. 26 illustrates the use of the bracket to anchor the exercise device. Bracket 2500 has a first flange 2503 with a mounting hole 2509 and a second flange 2505 with a mounting hole 2511 and a face 2507 that extends from the first flange to the second flange and includes a slot 2515 that extends
20 into the face a face edge 2513 and includes a central slot 2517. In a preferred embodiment, bracket 2500 is formed from a single sheet 2501 of sheet metal, for example that has crease 2517 in flange 2503, crease 2523 in flange 2505, and creases 2519 and 2521 between face 2507 and flanges 2503 and 2505, respectively. The preferred thickness of sheet 2501 is from 0.05 to 0.10
25 inches (1.3 to 2.5 mm), or more preferably approximately 0.0625 inches (1.6 mm), and creases 2517, 2519, 2521, and 2523 are placed to such that face 2507 is parallel to and separated from flanges 2503 and 2505 by a distance **D** of from approximately 1 to 2 inches (25 – 51 mm), or more preferably approximately 1.5 inches (38 mm). Mounting holes 2509 and 2511 are preferably between approximately 1/4 inch (6 mm) and approximately 1/2 inch (13 mm) in
30 diameter, and more preferably approximately 3/8 inch (9.5 mm) in diameter.

[0076] FIG. 26 illustrates the use of bracket 2500. Bracket 2500 is mounted to a wall **W**, and

held in place by a pair of screws **2601** through mounting holes **2509** and **2511**. A portion of anchor **410** is shown in phantom on the right side of FIG. 26, specifically enlarged portion **411** and flexible strap **413**. Anchor **410** is placed in bracket **2500** as indicated by the arrow.

Specifically, strap **413** is slid through the slot **2515** in face edge **2513**, with enlarged portion
5 between bracket **2500** and wall **W** and into central slot **2517**. Slot **2515** is sized to be large enough to allow strap **413** to slide through the slot but not so large as to allow enlarged portion **411** to pass through the slot. The use of bracket **2500** allows for exercise device **400**, which was previously shown as being mountable in a door jamb, to be mounted against any wall to which the bracket can be mounted.

10 [0077] The inventive exercise device allows for a wide range of exercises. Examples of the many exercises that are possible are presented in TABLE 1 for the inventive device placed over the top of a door. FIGS. 3 and 15 illustrate three of the many exercise positions. In each of these positions the user has selected a length for exercise device **100** or **400**, adjusted as explained with reference to FIGS. 12 or 13, has positioned himself on the ground a desired horizontal distance **X**
15 from anchor point **A** with a portion of his weight being supported by the exercise device. With his weight so supported, as shown in FIGS. 3 and 15, he moves his body in directions appropriate to the type of exercise to be performed, for example by moving his body toward or away from the wall or ground, by bending his arms or legs while supporting his weight by the exercise device, or performing other movements that exercise his muscles.

20 [0078] Specifically illustrated in FIGS. 3 and 15 are single poses of a user **U** performing a variety of exercises including a high row exercise (FIG. 3), a reverse combination crunch (FIG. 15A), a single leg L-squat (FIG. 15B), a gymnast dip (FIG. 15C), a kneeling combination crunch (FIG. 15D), a lying leg curl (FIG. 15E), a hip lift (FIG. 15F), a front shoulder raise (FIG. 15G), a crunch (FIG. 15H), and a triceps extension (FIG. 15I). It is apparent from FIGS. 3 and 15 that
25 many different types of exercises are possible with the inventive exercise device according to the length of the device, the positioning of the body, and how the handles are gripped.

[0079] In addition, the inventive device can be used to perform one handed exercises as illustrated in FIGS. 16A and 16B. Specifically, FIG. 16A shows an exercise device **400'** having interlocking the ends **421a** and **421b** for one handed exercises, and FIG. 16B illustrates the use
30 of the exercise device **400'** in performing a one arm high row exercise.

EXERCISE DEVICE ACCESSORIES

[0080] The utility of the exercise device of the present invention is greatly extended by providing a number of add-on grip accessories for the device, specifically by providing alternative grip devices for attaching to the grips of the exercise device.

5 [0081] In general, the grip accessories described herein are attachable to one of the pair of grips that are part of an exercise device, including but not limited to grips **123** of exercise device **100**, and provide an accessory grip whereby the user can exercise by applying forces to various part of the body, including the neck, all or part of the hand, arms, legs, toes, or the heel. Grip accessories allow the user to grip, such as by squeezing with sufficient force to support her
10 weight, and include devices that can hold the user within a loop or hook as the user pulls on the exercise device. In this context, a "grippable" portion refers to the ability to either wrap a body part around and squeeze a that portion of the grip accessory, or place a portion of the body through a loop or hook of the grip accessory so that the user can pull against the exercise device and keep the body part within the grip accessory.

15 [0082] The user may choose to exercise with the pair of grips having the same or different accessories, or without a grip accessory. In addition, the grip accessories of the present invention include a grip attachment portion that is removably attachable to the grip of an exercise device, such as exercise device **100** or any exercise device having two grips, and a portion that is
20 grippable by the hand, foot, fingers, or other parts of the body. The use of grip accessories allow a user to build additional strength in the hand or fingers by providing for different types of hand or finger gripping, and allows for additional exercises to be performed, as with the foot grip accessory. In addition, the pair of grips can be coupled, as discussed in reference to FIGS. 16A and 16B, allowing a user to exercises using one grip accessory.

[0083] One example of a grip accessory is foot grip accessory **1700**, which is illustrated in FIGS.
25 17A-17B as being attached to grips **123** of exercise device **100**. Specifically, FIG. 17A illustrates foot grip accessory **1700** attached to exercise device **100** and gripped by toes **T**, and FIG. 17B illustrates a pair of foot grip accessories, one on each of the pair of grips **123**, and each grasped by one of the user's heel **H1** and **H2**. Each foot grip accessory **1700** has a flexible loop **1710** and a grip attachment portion **1720** that is removably attachable, as discussed subsequently,
30 to one of the pair of grips **123**. It is preferred that the portion of loop **1710** that extends from grip **123** is approximately 12 inches (0.3 m) long to provide enough room for either a user's heel or toe fit through the loop. With foot grip accessory **1700** so secured, the toes (FIG. 17A) or heel

(FIG. 17B) can be placed through loop **1710**, and a force can be exerted by the foot against exercise device **100**.

[0084] In one embodiment of the present invention, each of the pair of grips **123** is provided with one foot grip accessory **1700**, facilitating exercises including, but not limited, to those
5 illustrated in FIGS. 15A and E.

[0085] A specific embodiment of foot grip accessory **1700** is illustrated in FIGS. 18A-D, where FIG. 18A is a perspective view of the foot grip accessory, FIG. 18B is a bottom view of the foot grip accessory, FIG. 18C is a side view of part of one of the grip attachment portions, and FIG. 18D is a top view of part of one of the grip accessory attachment portions. As shown in FIGS.
10 18A and 18B, foot grip **1700** is formed from three straps: a loop strap **1801** and two attachment straps **1803**. With the three straps attached, as described subsequently, loop strap **1801** forms loop **1710** and the two attachment straps **1803** forms the grip attachment portion **1720**.

[0086] It is preferred that the majority of foot grip accessory **1700** is formed of materials that include, but are not limited, to straps of a webbing of a natural or synthetic material having a
15 strength sufficient to support the weight of a device user. Preferred webbings include, but are not limited to, polymeric fiber webbings made of, for example, nylon or polypropylene or some other polymeric fiber. It is understood that a single length of flexible material according to the present invention can alternatively comprise two or more pieces that are stitched, glued, or otherwise attached to one another.

[0087] Loop strap **1801** is formed from a length of strapping having ends that are joined to form a loop. Loop strap **1801** is preferably polymeric fiber webbing 20 inches (0.5 m) long and 1.5 inches (38 mm) wide. In the preferred embodiment, the loop includes two triangular shaped double stitched portions **1815**, one of which joins the two ends of loop strap **1801**. Each of the two grip attachment straps **1803** is formed from a length of strapping having a first end **1807**
25 with a first fastening surface **1809** and a second end **1811** with a second fastening surface **1813**. Attachment straps **1803** are preferably polymeric fiber webbing having a length of 7.5 inches (190 mm) and a width of 1.5 inches (38 mm). Fastening surfaces **1809** and **1811** are preferably attached to loop strap **1801** by double stitching **1817**, and grip attachment straps **1803** are preferably joined midway between ends **1807** and **1811** to the loop strap by double stitching
30 **1805**.

[0088] Each attachment strap **1803** includes fastening surfaces **1809** and **1813** are on opposite

sides of the strap. It is preferred that fastening surfaces **1809** and **1813** are matching surfaces, such as matching hook and loop surfaces of a hook and loop fastening system, such as VELCRO® brand hook and loop fasteners. In a preferred embodiment, fastening surfaces **1809** and **1813** are each approximately 2 inches (51 mm) by 1.25 inches (32 mm).

5 [0089] Foot grip accessory **1700** is removably attachable and is used as follows. Grip attachment portion **1720** of foot grip accessory **1700** is removably attachable to one of the pair of grips **123**, by wrapping the length of each strap **1703** about grip **123a** and contacting fastening surfaces **1809** and **1813** on each strap **1803**. With foot grip accessory **1700** so secured, the toes (FIG. 18A) or heel (FIG. 18B) can be placed through loop **1710**, and a force can be exerted by
10 the foot against exercise device **100**. Stitching **1815** allows loop **1710** to open without twisting and provides a secure strap for securing the foot.

[0090] Another example of a grip accessory is finger grip accessory **1900**, which is illustrated in FIGS. 19A-19C with three different exercises when attached to grips **123** of exercise device **100**. Finger grip assembly **1900** has loops **1910** adapted for receiving and being gripped by the thumb
15 and one or more fingers and a grip attachment portion **1920** for attaching the accessory to the grip of an exercise device. Grip attachment portion **1920** is removably attachable to one of the pair of grips **123**. In one embodiment, there are two loops **1910**: a first loop **1910a**, and a second loop **1910b**. With finger grip accessory **1900** so secured, a finger **F1** can be placed through one of the loops, for example first loop **1910a** as shown in FIG. 19A, a finger **F1** can be placed
20 through the first loop and a finger **F2** can be placed through second loop **1910b** as shown in FIG. 19B, or two fingers, **F1** and **F2** can be placed through the first loop and a finger **F3** and a finger **F4** can be placed through the second loop, as shown in FIG. 19C.

[0091] In one embodiment, each of the pair of grips **123** is provided with one finger grip accessory **1900**. With the finger or fingers so placed through at least one of loops **1910**, a force
25 can be exerted by the pulling against exercise device **100**. Finger grip accessory **1900** has similar functionality as finger grips **4001**.

[0092] A specific embodiment of finger grip accessory **1900** is illustrated in FIGS. 20A-C, where FIG. 20A is a perspective view of the finger grip accessory, FIG. 20B is a top view
30 20B of the finger grip accessory, and FIG. 20C is a sectional side view 20C-20C of the finger grip accessory. Finger grip accessory **1900** includes two loops **1910**, first loop **1910a** and second loop **1910b**, and grip attachment portion **1920** includes three portions **1920a**, **1920b**, and **1920c**.

More specifically, finger grip accessory **1900** is formed from five straps: a loop strap **2001**, three attachment straps **1803**, and a backing strap **1903**. With the five straps attached, as described subsequently, loop strap **2001** forms first loop **1910a** and finger loop **1910b**, that can each receive one or more fingers, and each of the three attachment straps **1803** forms one of grip
5 attachment portion **1920a**, **1920b**, and **1920c**. It is preferred that the majority of finger grip **1900** is formed of the same materials as hand grip **1700**.

[0093] In a preferred embodiment, loop strap **2001** is constructed from a polymeric fiber webbing having a length of 21.5 inches (0.55 m) long and a width of 1 inch (25 mm), and backing strip **2003** is preferably a polymeric fiber webbing having a length of 2 inches (51 mm)
10 and a width of 1 inch (25 mm). Preferred attachment straps **1803** have been discussed previously. Finger grip accessory **1900** is assembled by three stitches **2007** that each pass through one of the three attachment straps **1803** and through loop strap **2001** and backing strap **2003**. In the preferred embodiment, stitching **2007** is double stitched portions. As is shown in FIGS. 20A and 20C, a portion of loop strap **2001** protrudes between each of the three attachment
15 straps **1803** to form loops **1910a** and **1910b**. It is preferred that loops **1910a** and **1910b** are formed from lengths of loop strap **1901** that are approximately 8 inches (0.2 m). Loop strap **2001** preferably extends the length of backing strap **2003**, with two loops **1910a** and **1910b** between adjacent attachment straps **1803**.

[0094] Finger grip accessory **1900** is removably attachable and is used as follows. Grip
20 attachment portion **1920** of finger grip accessory **1900** is removably attachable to one of the pair of grips **123** by the contact of fastening surfaces **1809** and **1813** on each strap **1803**. With finger grip accessory **1900** so secured, a finger may be placed through one of the loops, for example loop **1910a** as shown in FIG. 20A, one finger can be placed through each of loop **1910a** and **1910b** as shown in FIG. 20B, or two fingers can be placed through each of loop **1910a** and
25 **1910b** as shown in FIG. 20C. With the finger or fingers so placed through at least one of loops **1910**, a force can be exerted by the user against exercise device **100**.

[0095] A third example of a grip accessory is grip accessory **2100**, which is illustrated in FIGS. 21A-21C as being attached to grips **123** of exercise device **100**. Grip accessory **2100** has several
30 cords **2110** that can be gripped in different combinations, as explained subsequently, and a grip attachment portion **2120**. In general, the number of cords **2110** can be from one to five, or more, with four being a preferred number, and with each cord having the same diameter and length. It is also preferred that the cords have a grippable length large enough for a human hand, for

example a length from 4 inches (0.1 m) to 6 inches (0.15 m), and that there is enough additional length to allow the user to pass her hand between cords, as illustrated in FIGS. 21A-21C. The present invention is illustrated by grip accessory **2100** having four cords, denoted as a first cord **2110a**, a second cord **2110b**, a third cord **2110c**, and a fourth cord **2110d**. The cords can be gripped in almost any combination so that a user can grip any number of cords, from one cord to all 4 cords. FIG. 21A illustrates hand **H** gripping three cords, for example the first cord **2110a**, second cord **2110b**, and third cord **2110c**, FIG. 22B illustrates the hand gripping two cords, for example the first and second cords, and FIG. 22C illustrates the hand gripping one cord, for example the first cord.

10 [0096] Grip attachment portion **2120** is removably attachable, as discussed subsequently, to one of the pair of grips **123**. With grip accessory **2100** so secured, between one and all of cords **2210** can be gripped, and a force can be exerted by pulling against exercise device **100**. In one embodiment, each of the pair of grips **123** is provided with one grip accessory **2100**.

[0097] A specific embodiment of grip accessory **2100** is illustrated in FIGS. 22A-D, where FIG. 21A is a perspective view of the grip accessory, FIG. 21B is a top view of the grip accessory, FIG. 21C is a bottom view of the grip accessory, and FIG. 21D is sectional side view 21D-21D of FIG. 21C. Grip accessory **2100** is formed from four straps, specifically a backing strap **2205**, a front strap **2207**, and two attachment straps **1703**, and two cords **2201** and **2203**. Cords **2110** are formed from two longer cords **2201** and **2203**, and grip attachment portion **2120** is formed from straps **2205**, **2207**, and **1703**.

[0098] The two straps **1703** forming grip attachment portion **2120** are attached at their respective central portions between the ends of backing strap **2205** and front strap **2207**. The four cords **2110a-d** are formed from the longer cords **2201** and **2203**. Specifically, as shown in FIG. 22B, cords **2201** and **2203** are side-by-side and folded in half. Each cord forms a loop **2213** near the middle of cords **2201** and **2203**, with both cords lashed together by whipping **2109** and to form a loop **2113** and with the four ends of cords **2201** and **2203** lashed by whipping **2109**. In the sectional view of FIG. 22D, cord **2203** is shown with a first end **2213** and second end **2217** lashed together by whipping **2209**, and a central portion **2215** forming loop **2213** about strap **2207**. Each cord **2201** and **2203** is folded in half, and thus each cord forms two cords between whippings **2109** and **2111**. Specifically, cord **2201** form cords **2210a** and **2210b**, and cord **2203** forms cords **2210c** and **2210d**.

[0099] Straps **2105** and **2107** are preferably polymeric fiber webbings. Backing strap **2105** preferably has a length of 5 inches (0.13 m) and a width of 1 inch (25 mm), and front strap **2107** preferably has a length of 6 inches (0.15 m) and a width of 1 inch (25 mm). Cords **2201** and **2203** are preferably cotton cord having a length of from approximately 20 inches (0.5 m) to approximately 30 inches (0.75 m), and more preferably from approximately 22 inches (0.56 m) to approximately 26 inches (0.66 m), and still more preferably approximately 24 inches (0.6 m) in length. Cords **2201** and **2203** have a diameter that is preferably from 1/2 inch (13 mm) to 1 inch (25 mm), and more preferably approximately 3/4 inches (19 mm). The joints between straps **2105** and **2107** and attachment straps **1703** are preferably double stitched. The resulting grip attachment **2100** has four cords with approximately 10 inches (0.25 m) of grippable length, allowing enough room for a human hand to pass between and grip cords **2110**.

[0100] Grip accessory **2100** is removably attachable and is used as follows. Grip attachment portion **2120** is removably attachable to one of the pair of grips **123** by the contact of fastening surfaces **1809** and **1813** on each strap **1803**. With finger grip accessory **2100** so secured, one, two, three, or all four of cords **2110a-d** may be gripped by the hand. For example, FIG. 22A illustrates cords **2110a**, **2110b**, and **2110c** gripped by a user, FIG. 22B illustrates cords **2110a** and **2110b** gripped by a user, and FIG. 22C illustrates cord **2110a** gripped by a user. With cords **2110** so gripped, a force can be exerted by the user against exercise device **100**.

[0101] It is to be understood that this invention is not limited to those embodiments and modifications described in the specification. Modifications and variations can be made by one skilled in the art without departing from the spirit and scope of the invention. For example, the various inelastic members are described herein as straps, this is not meant to limit the actual shape of the inelastic member, which could be round, as in a cord. Moreover, any one or more features of any embodiment of the invention may be combined with any one or more other features of any other embodiment of the invention, without departing from the scope of the invention.

I Claim:

1. An adjustable, inelastic exercise device comprising:
 - an elongated member having a pair of ends separated by a length and a
5 mechanism for adjusting said length, said pair of ends including a first end having a first grip and a second end having a second grip; and
 - an anchor having a first portion for mounting said device to a structure and a second portion to support said elongated member at a position along said length when both of said grips are pulled in a direction away from said anchor,
10 where said support and elongated member interact to provide frictional restraint with respect to the anchor as a function of the force applied to each of said pulled grips.
2. The exercise device of claim 1, wherein said first portion is removably attachable to a structure.
3. The exercise device of claim 1, wherein said first grip and said second grip are hand
15 grips.
4. The exercise device of claim 1, wherein at least one of said first grip and said second grip is a finger grip.
5. The exercise device of claim 1, wherein said elongated member includes at least one strap and said mechanism includes at least one cam buckle, such that said length is adjustable
20 according to the length of strap through said cam buckle.
6. The exercise device of claim 5, said mechanism further including two cam buckles, wherein one of two cam buckles is adjacent to said first grip and wherein the other of said two cam buckles is adjacent to said second grip.
7. The exercise device of claim 2, wherein said structure is a closed door having a door
25 jamb, wherein said anchor includes a strap that is passable between said closed door and said door jamb and where a part of said first portion is not passable between said closed door and said door jamb.
8. The exercise device of claim 7, wherein the material of said first portion that contacts said structure is softer than said structure, such that said anchor will not scratch said structure.
- 30 9. The exercise device of claim 2, wherein said second portion includes a loop.
10. The exercise device of claim 2, wherein said structure is a pole, rail, or stanchion, wherein said first portion includes a tensioning device, wherein said strap has a length sufficiently long to wrap about said structure, and wherein said tensioning device is adapted for tightening said strap about said structure.

11. The exercise device of claim 1, wherein said length of said elongated member is adjustable between 6 feet (1.8 m) and 12 feet (3.6 m).

12. The exercise device of claim 1, wherein, when said forces are increased while positioning each of said grips a distance of one half of said length from said anchor, said frictional restraint
5 restrains said elongated member with said grips equidistant from said anchor.

13. An adjustable, inelastic exercise device comprising:

an elongated member including at least one strap, a pair of ends separated by a length, and a pair of cam buckles including a first cam buckle adjacent to one of said pair of ends and a second cam buckle adjacent to the other of said pair of ends, where said
10 length is adjustable according to the length of strap through said cam buckles; and

an anchor having a first portion for mounting said device to a structure and a second portion to support said elongated member at a position along said length when both of said grips are pulled in a direction away from said anchor,

where said support and elongated member interact to provide frictional restraint
15 with respect to the anchor as a function of the force applied to each of said pulled grips.

14. The exercise device of claim 13, wherein said first portion is removably attachable to a structure.

15. The exercise device of claim 13, wherein said first grip and said second grip are hand grips.

20 16. The exercise device of claim 13, wherein at least one of said first grip and said second grip is a finger grip.

17. The exercise device of claim 14, wherein said structure is a closed door having a door jamb, wherein said first portion includes a strap that is passable between said closed door and said door jamb and an enlarged end that is not passable between said closed door and said door
25 jamb.

18. The exercise device of claim 17, wherein the material of said anchor that contacts said structure is softer than said structure, such that said anchor will not scratch said structure.

19. The exercise device of claim 17, wherein said second portion includes a loop.

20. The exercise device of claim 14, wherein said structure is a pole, rail, or stanchion,
30 wherein said first portion includes a tensioning device, wherein said strap has a length sufficiently long to wrap about said structure, and wherein said tensioning device is adapted for tightening said strap about said structure.

21. The exercise device of claim 13, wherein said length of said elongated member is adjustable between 6 feet (1.8 m) and 12 feet (3.6 m).

22. The exercise device of claim 13, wherein, when said forces are increased while positioning each of said grips a distance of one half of said length from said anchor, said frictional restraint restrains said elongated member with said grips equidistant from said anchor.

23. An adjustable, inelastic exercise device comprising:

5 an elongated member having a pair of ends separated by a length and a mechanism for adjusting said length, said pair of ends including a first end having a first grip and a second end having a second grip; and

an anchor having a first portion for mounting said device to a structure and a second portion to support said elongated member at a position along said length when
10 both of said grips are pulled in a direction away from said anchor,

where said support and elongated member interact to provide frictional restraint with respect to the anchor as a function of the force applied to each of said pulled grips.

24. The exercise device of claim 23, wherein said first grip and said second grip are hand grips.

15 25. The exercise device of claim 23, wherein at least one of said first grip and said second grip is a finger grip.

26. The exercise device of claim 23, wherein said elongated member includes at least one strap and said mechanism includes at least one cam buckle, such that said length is adjustable according to the length of strap through said cam buckle.

20 27. The exercise device of claim 26, wherein said device includes a first cam buckle and a second cam buckle, wherein said first cam buckles is adjacent to said first grip, and wherein said second cam buckle is adjacent to said second grip.

28. The exercise device of claim 23, wherein said supporting structure is a closed door having a door jamb, wherein said anchor includes a strap that is passable between said closed
25 door and said door jamb and has a first end for slidably supporting said elongated member and a second end that is not passable between said closed door and said door jamb.

29. The exercise device of claim 28, wherein the material of said anchor second end that contacts said door and said door jamb is softer than either said door or said door jamb, such that said anchor will not scratch said door or said door jamb.

30 30. The exercise device of claim 28, wherein said anchor includes a loop for supporting said elongated member.

31. The exercise device of claim 23, wherein said structure is a pole, rail, or stanchion, wherein said first portion includes a tensioning device, wherein said strap has a length sufficiently long to wrap about said structure, and wherein said tensioning device is adapted for

tightening said strap about said structure.

32. The exercise device of claim 23, wherein said length of said elongated member is adjustable between 6 feet (1.8 m) and 12 feet (3.6 m).

33. The exercise device of claim 23, wherein, when said forces are increased while
5 positioning each of said grips a distance of one half of said length from said anchor, said frictional restraint restrains said elongated member with said grips equidistant from said anchor.

34. A portable exercise apparatus comprising:
a resistance exercise device having at least one integral grip; and
an accessory grip removably coupled to said at least one integral grip.

10 35. The portable exercise apparatus of claim 34,
wherein said at least one integral grip is a pair of integral grips, and
wherein said resistance exercise device further includes
an inelastic elongated member between said pair of integral grips, and
an anchor for attaching said elongated member to a stationary support.

15 36. The portable exercise apparatus of claim 35, wherein said anchor has a first end slidably attached to said elongated inelastic member between said pair of grips and a second end adapted for attaching to said stationary support.

37. The portable exercise apparatus of claim 35, wherein said inelastic elongated member further includes a mechanism to adjust the length of said elongated inelastic member between
20 said pair of integral grips.

38. The portable exercise apparatus of claim 35, wherein each of said pair of integral grips includes one of a pair of rigid elongated members each having an outer circumference.

39. The portable exercise apparatus of claim 38, wherein said accessory grip has a grip attachment portion including at least one strap having a length greater than the outer
25 circumference and includes a fastener to secure said grip attachment portion about one of said pair of integral grips.

40. The portable exercise apparatus of claim 39, wherein said fastener is a hook-and-loop fastener.

41. The portable exercise apparatus of claim 34, wherein said accessory grip includes a loop
30 adapted for accepting a heel of a user.

42. The portable exercise apparatus of claim 34, wherein said accessory grip includes one or more loops each adapted for accepting at least one finger of a user.

43. The portable exercise apparatus of claim 34, wherein said accessory grip includes a plurality of cords adapted for gripping, in any combination, by a hand of a user.

44. The portable exercise apparatus of claim 43, wherein each of said plurality of cords has a portion with a length greater than 4 inches (0.1 m) and a diameter of from 1/4 inch (6 mm) to approximately 1 inch (25 mm), and a joint mutually connecting said plurality of cords,

where said plurality of cords is sufficiently flexible to adjacently arrange two or
5 more of said portions of said plurality of cords.

45. The portable exercise apparatus of claim 44, wherein each of said plurality cords has a second end, and where said second ends are joined.

46. The portable exercise apparatus of claim 45, wherein the distance from said joint to said second ends is approximately 10 inches (0.25 m).

10 47. The portable exercise apparatus of claim 37, wherein said mechanism includes at least one cam buckle, such that said length is adjustable according to the length of said elongated inelastic member through said cam buckle.

48. The portable exercise apparatus of claim 47, wherein said at least one cam buckle is two cam buckles, wherein each of said two cam buckles is adjacent to one of said pair of integral
15 grips.

49. The portable exercise apparatus of claim 35, wherein said stationary support is a closed door having a door jamb, wherein said anchor includes an enlarged portion at said second end and a strap between said first end and said second end that is passable between said closed door and said door jamb, and wherein said enlarged portion is not passable between said closed door
20 and said door jamb.

50. The portable exercise apparatus of claim 35, wherein said stationary support is a pole, rail, or stanchion, wherein said first portion includes a tensioning device, wherein said strap has a length sufficiently long to wrap about said structure, and wherein said tensioning device is adapted for tightening said strap about said structure.

25 51. The portable exercise apparatus of claim 34, wherein said length of said elongated member is between 6 feet (1.8 m) and 12 feet (3.6 m).

52. The portable exercise apparatus of claim 36, wherein, when said forces are increased while positioning each of said pair of integral grips a distance of one half of said length from said anchor, said frictional restraint restrains said elongated member with said integral grips
30 equidistant from said anchor.

53. The portable exercise device of claim 36, wherein said anchor includes an enlarged portion at said second end and a strap between said first end and said second end, wherein said stationary support is a wall, and further includes:

a bracket having a first portion affixed to said wall and a second portion having an

opening and spaced apart from said first portion,

where said opening in said second portion is adapted to accept said strap, where said spacing between said wall and said second portion is sufficient to accept said enlarged portion, and where said opening is sufficiently small to prevent said enlarged portion from passing through said opening.

- 5
54. The portable exercise apparatus of claim 34, wherein said at least one integral grip is a pair of integral grips, and wherein said resistance exercise device further includes an elastic elongated member between said pair of integral grips.
- 10 55. An accessory for attaching to an integral grip of a resistance exercise device comprising:
an accessory grip; and
an attachment portion coupled to said accessory grip and removably attachable to said integral grip,
such that said exercise apparatus provides resistance through said accessory grip.
- 15 56. The accessory of claim 55, wherein said integral grip includes a rigid elongated member having an outer circumference.
57. The accessory of claim 56, where said attachment portion includes at least one strap having a length greater than the outer circumference of one of said rigid elongated members and includes a fastener to secure said at least one strap about one of said rigid elongated members.
- 20 58. The accessory of claim 57, wherein said fastener is a hook-and-loop fastener.
59. The accessory of claim 55, wherein said accessory grip includes a loop adapted for accepting a heel of a user.
60. The accessory of claim 55, wherein said grip portion includes one or more loops each adapted for accepting at least one finger of a user.
- 25 61. The accessory of claim 55, wherein said grip portion includes two or more cords adapted for gripping, in any combination, by a hand of a user.
62. The accessory of claim 61, wherein each of said plurality of cords has a portion with a length greater than 4 inches (0.1 m) and a diameter of from 1/4 inch (6 mm) to approximately 1 inch (25 mm), and a joint mutually connecting said plurality of cords,
30 where said plurality of cords is sufficiently flexible to adjacently arrange two or more of said portions of said plurality of cords.
63. The accessory of claim 62, wherein each of said plurality cords has a second end, and where said second ends are joined.
64. The accessory of claim 63, wherein the distance from said joint to said second ends is

approximately 10 inches (0.25 m).

65. A grip for an exercise device comprising:

a plurality of cords each having a portion with a length greater than 4 inches (0.1 m) and a diameter of from 1/4 inch (6 mm) to approximately 1 inch (25 mm); and

a joint mutually connecting said plurality of cords and connected to said exercise device,

where said plurality of cords is sufficiently flexible to adjacently arrange two or more of said portions of said plurality of cords,

such that a user can grip two or more of portions of said plurality of elongated members.

66. The grip of claim 65, wherein each of said plurality cords has a second end, and where said second ends are joined.

67. The grip of claim 66, wherein the distance from said joint to said second ends is approximately 10 inches (0.25 m).

68. A device for anchoring an exercise device to a wall, where said exercise device includes a pair of grips and an anchor having a strap with an enlarged end, said device comprising:

a bracket having a first portion to affix to said wall and a second portion having an opening and spaced apart from an affixed wall,

where said opening is adapted to accept said strap of said anchor, where said spacing between said second portion and an affixed wall is sufficient to accept said enlarged portion between said accepted strap and said affixed stationary support, and where said opening is sufficiently small to prevent said enlarged portion from passing through said opening,

such that said anchor of said exercise device is removably supportable by said opening of said bracket.

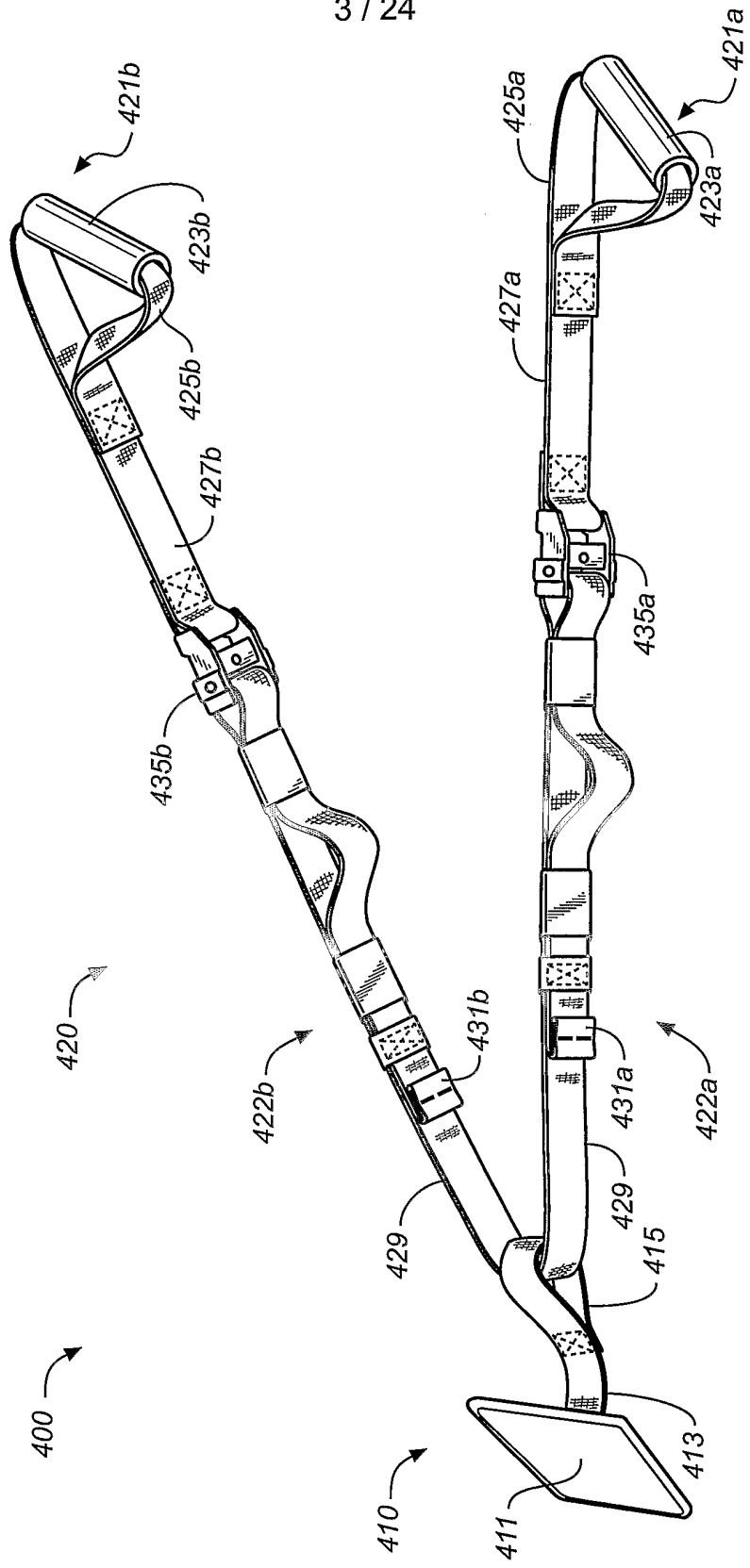

FIG. 4

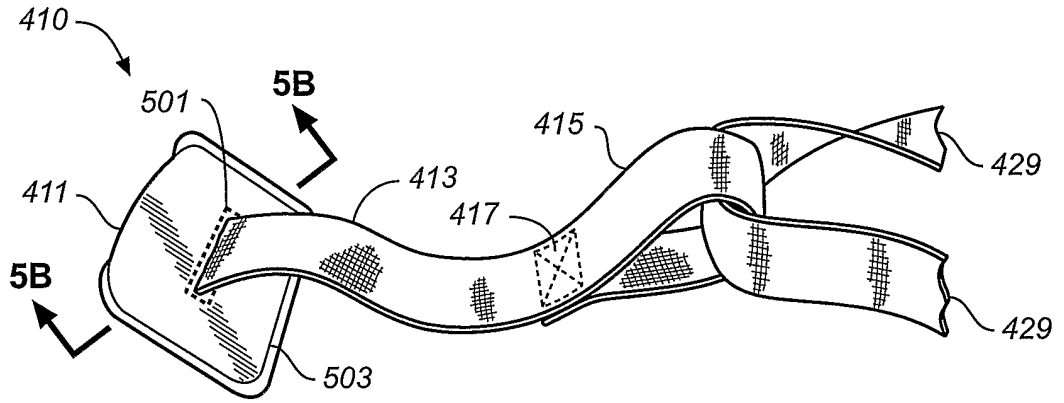

FIG. 5A

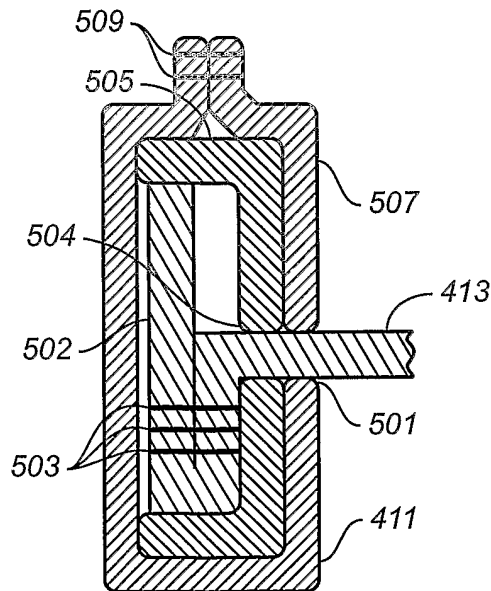

FIG. 5B

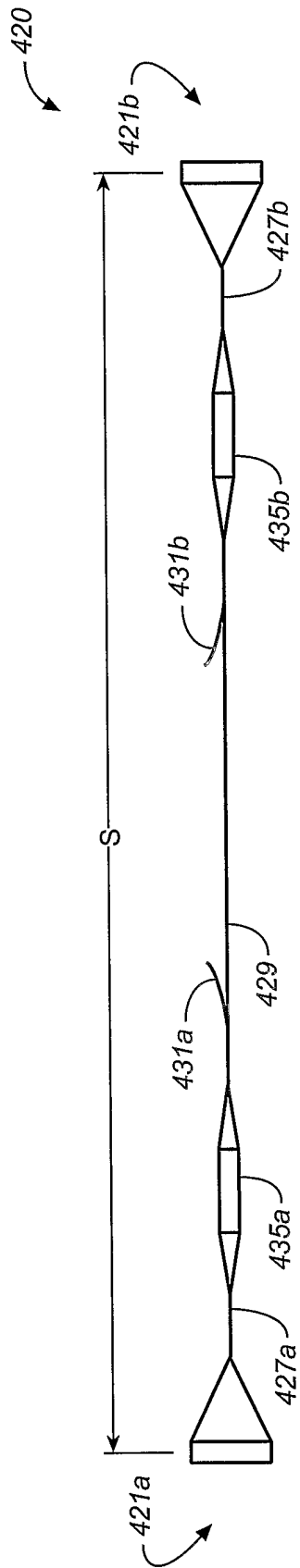

FIG. 6

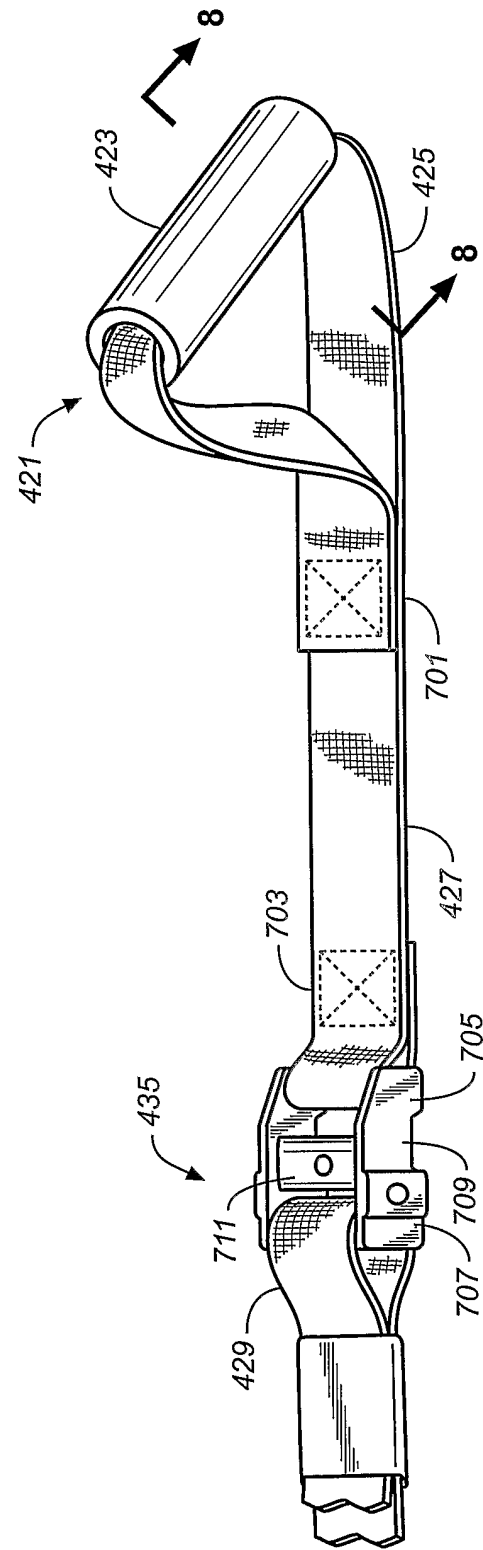

FIG. 7

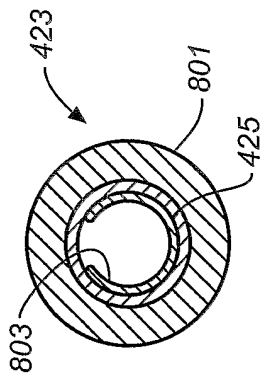

FIG. 8

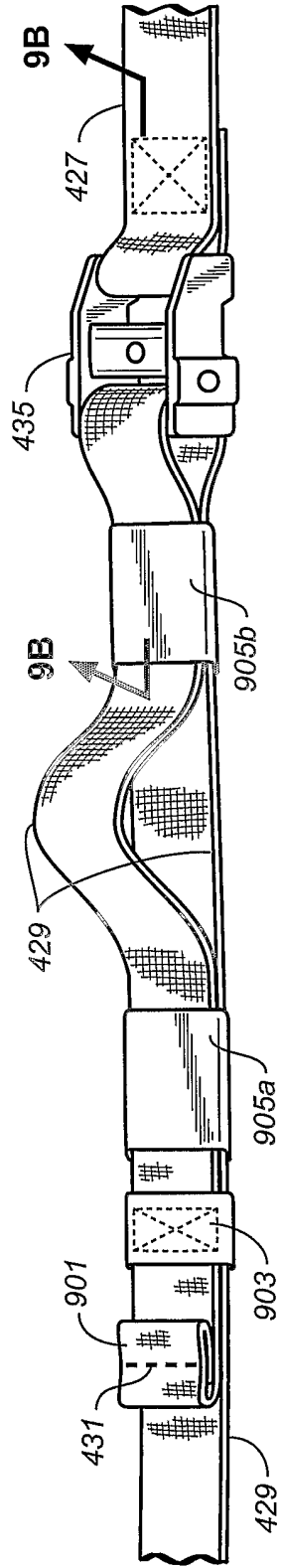

FIG. 9A

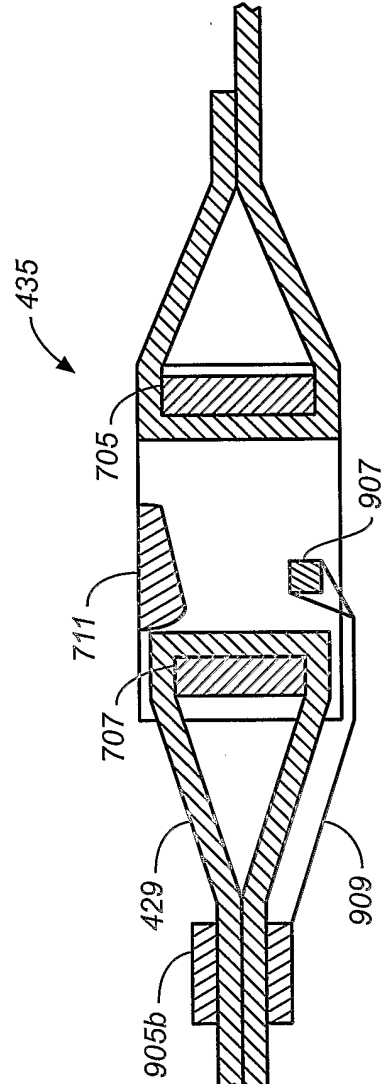

FIG. 9B

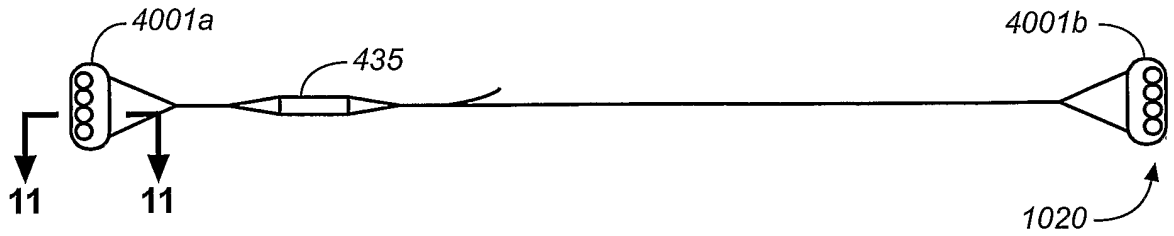

FIG. _10

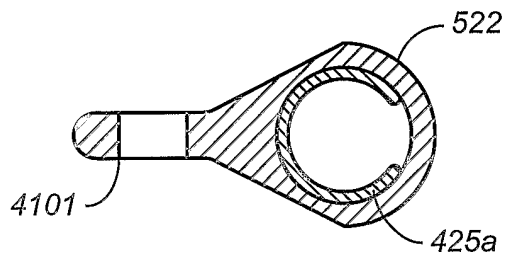

FIG. _11

8 / 24

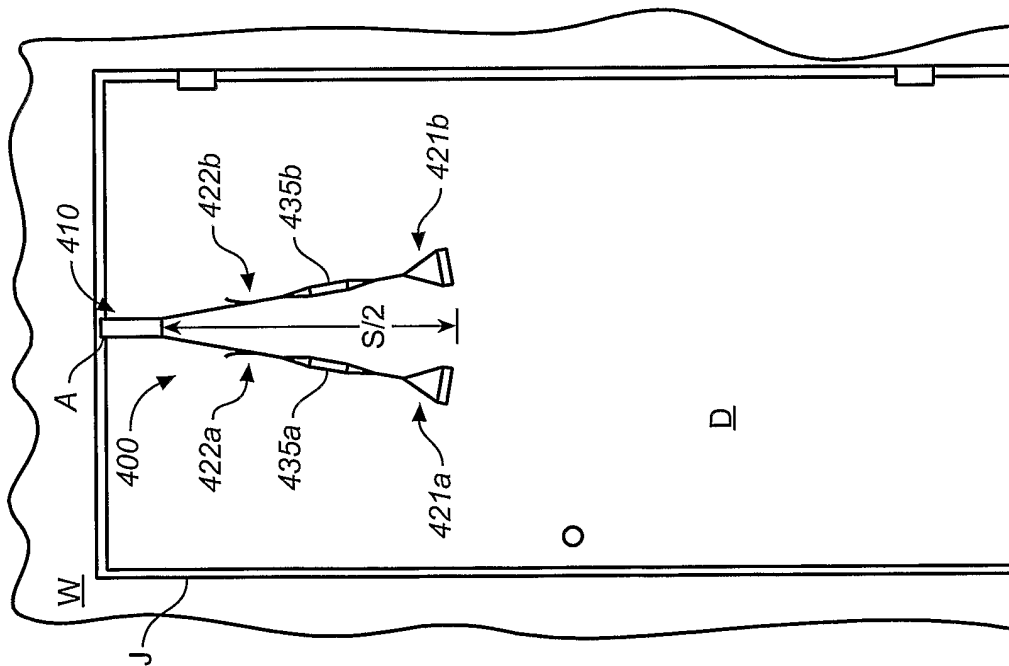

FIG. 12A

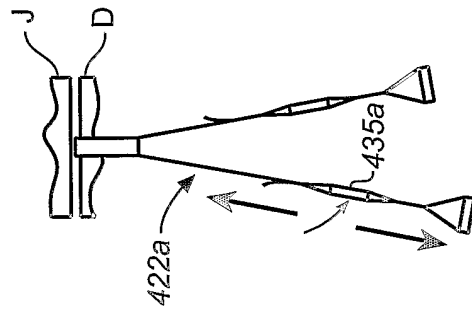

FIG. 12B

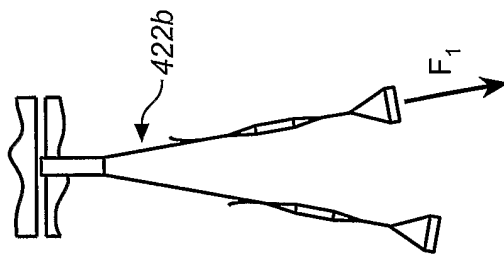

FIG. 12C

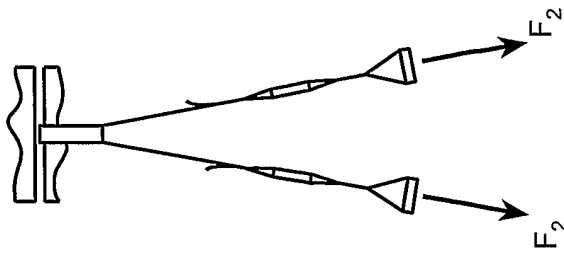

FIG. 12D

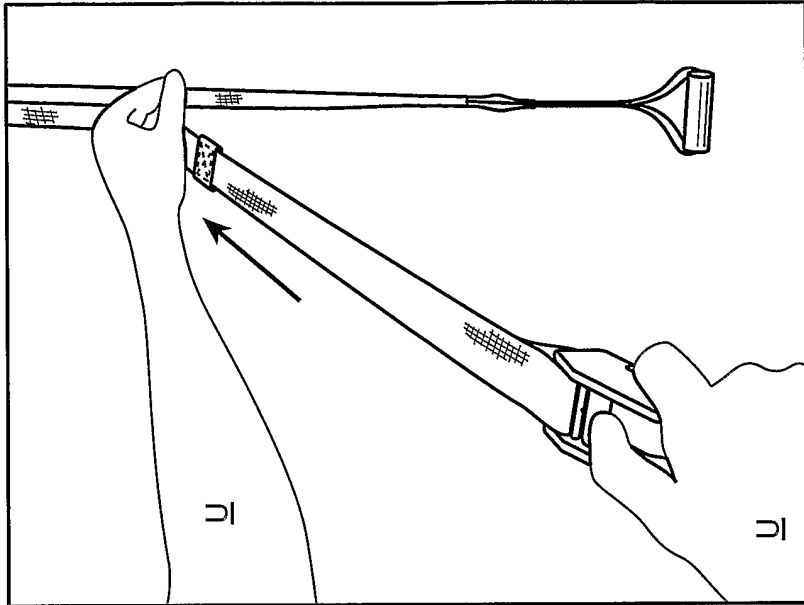

FIG. 12B'

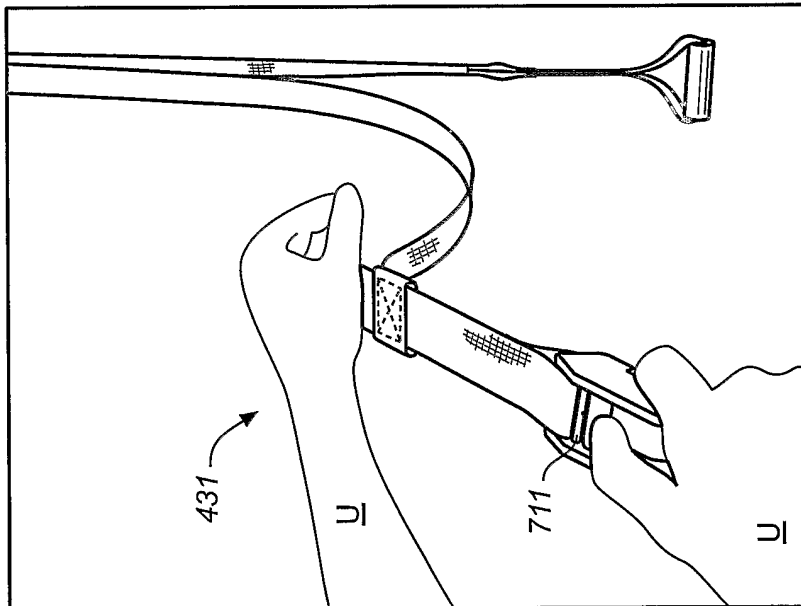

FIG. 12B'

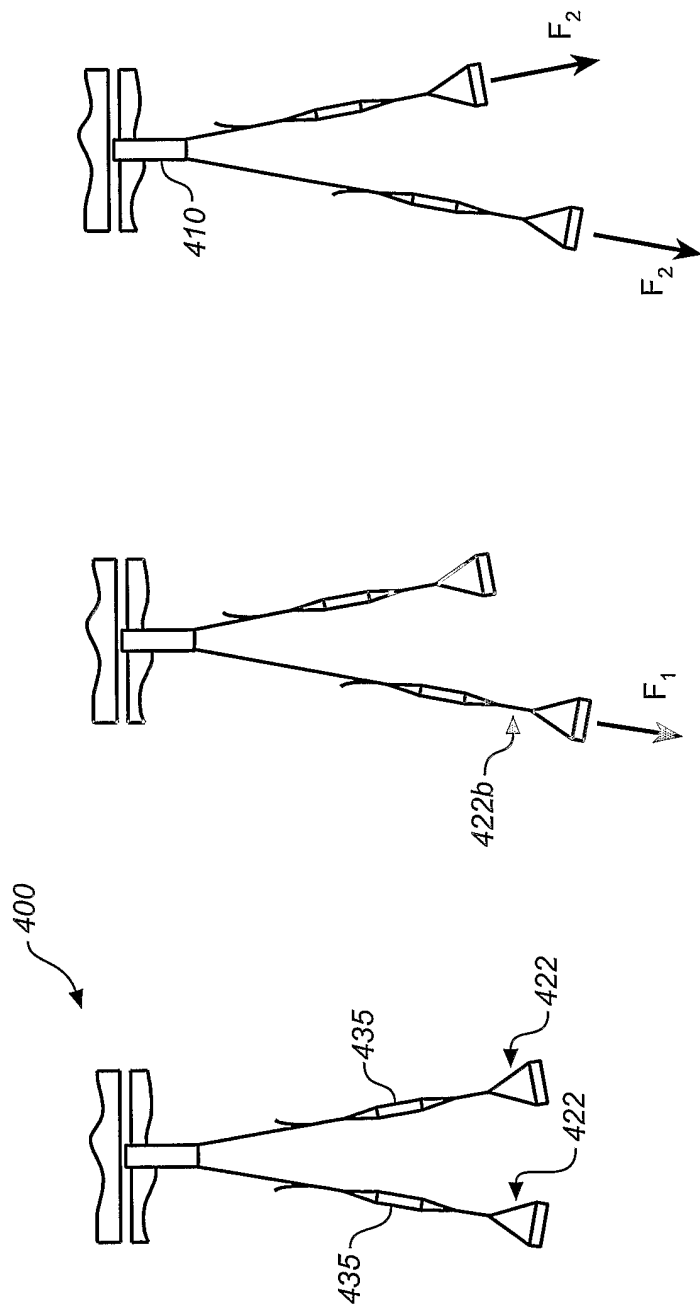

FIG. 13C

FIG. 13B

FIG. 13A

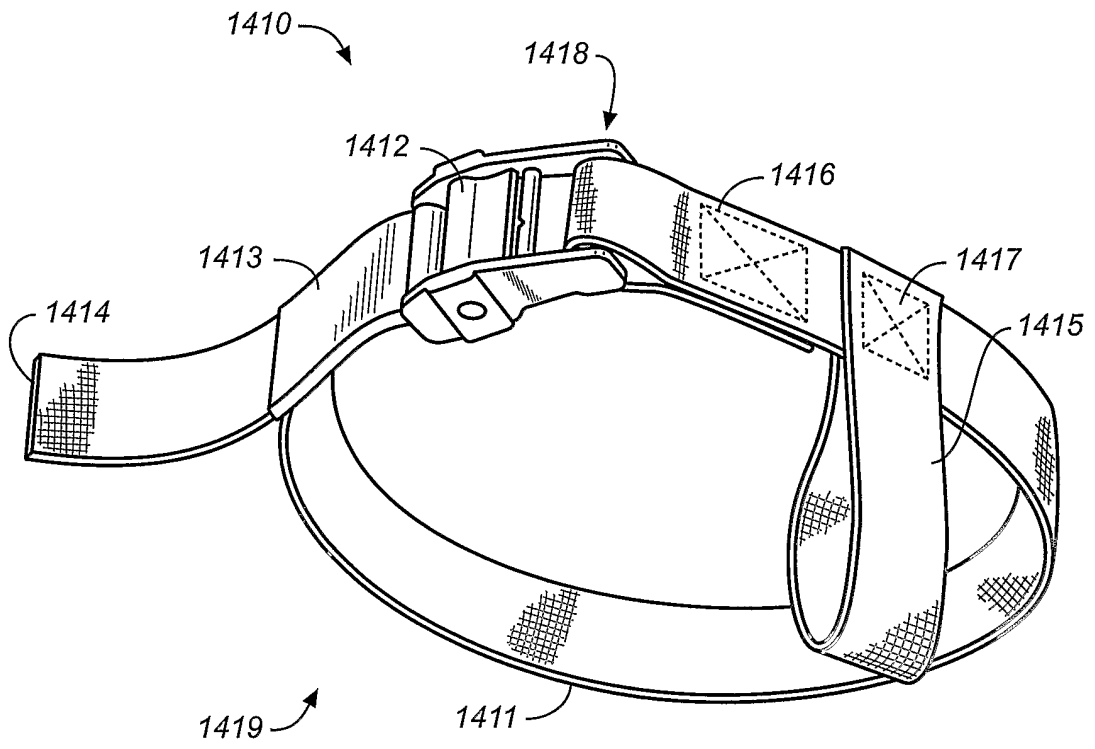

FIG. 14A

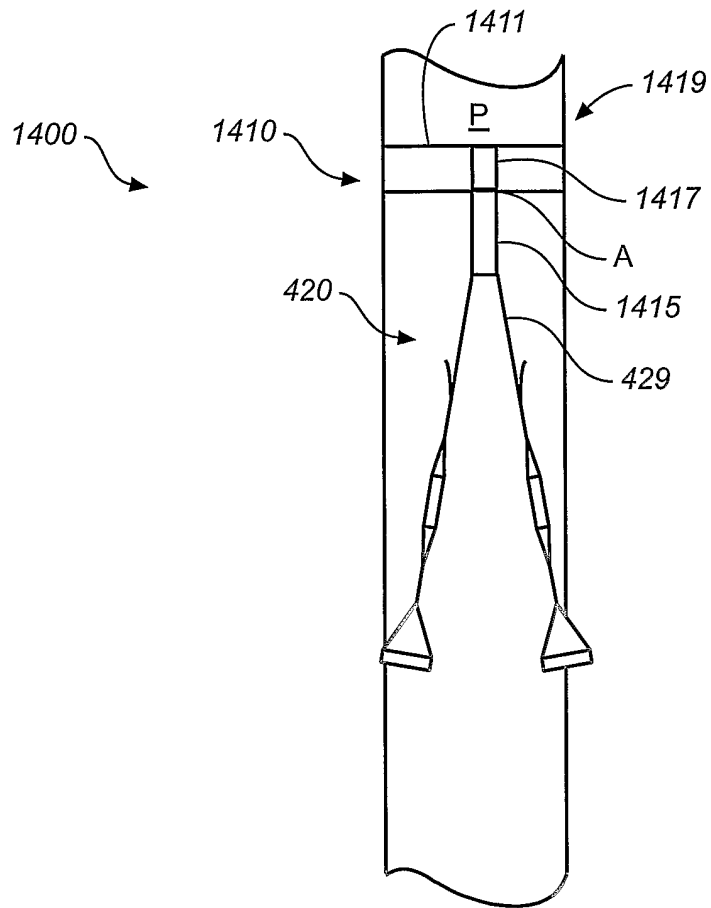

FIG. 14B

FIG. 15A

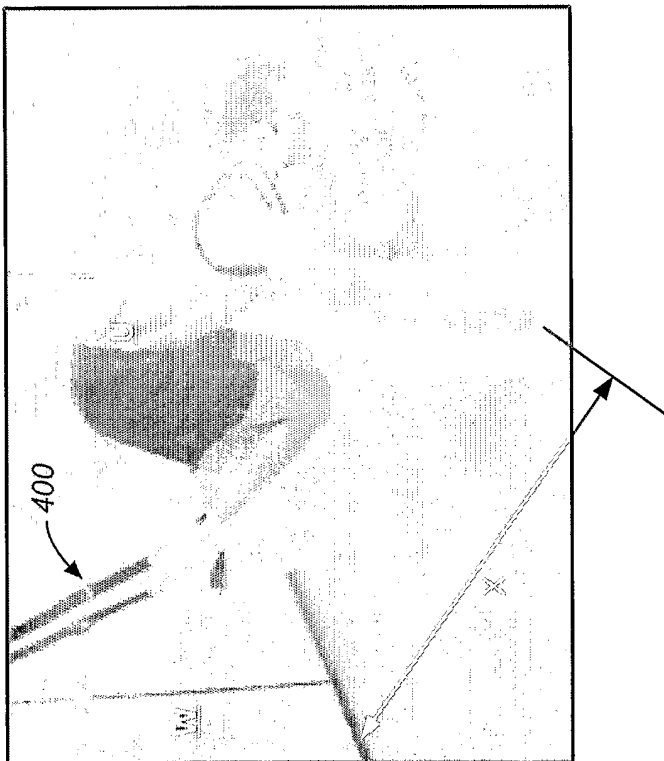
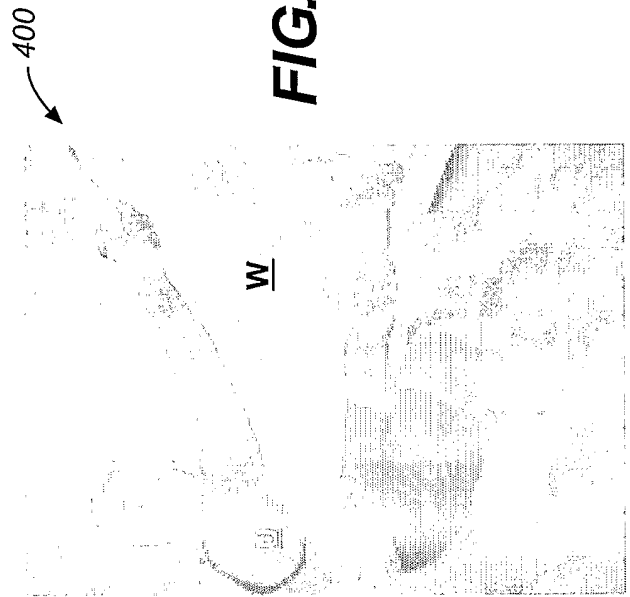

FIG. 15B



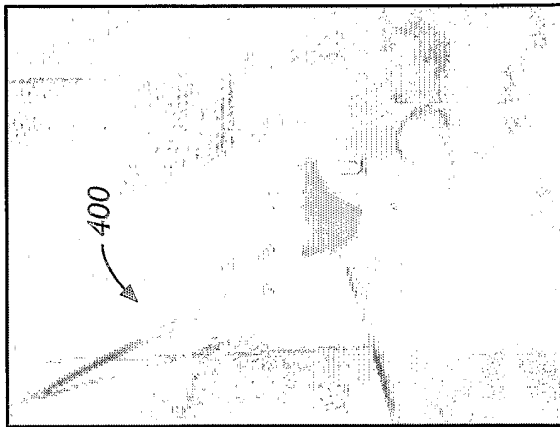

FIG. 15E

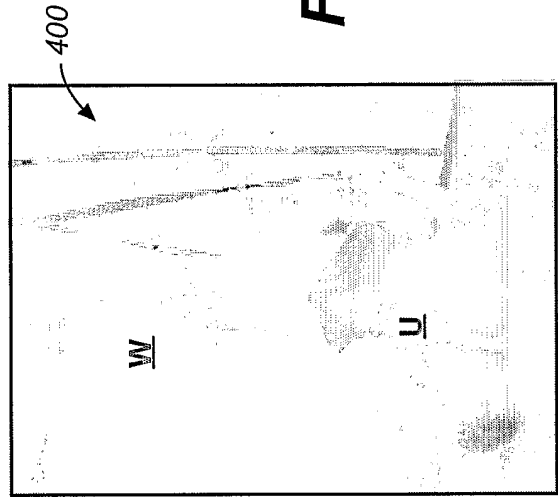

FIG. 15F

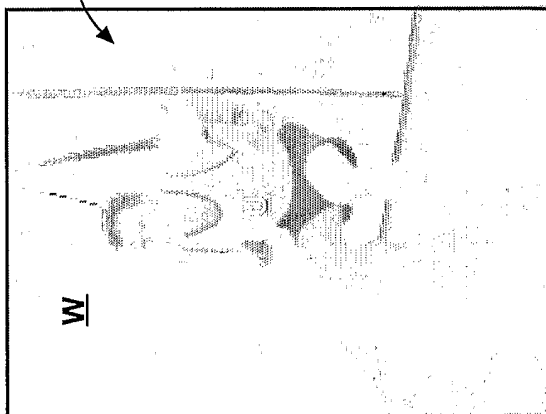

FIG. 15C

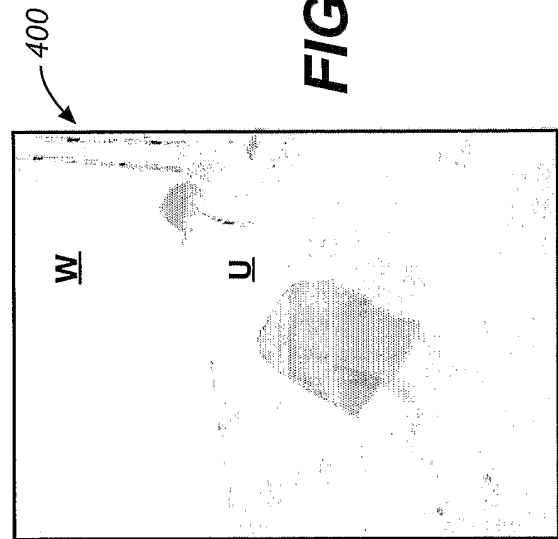

FIG. 15D

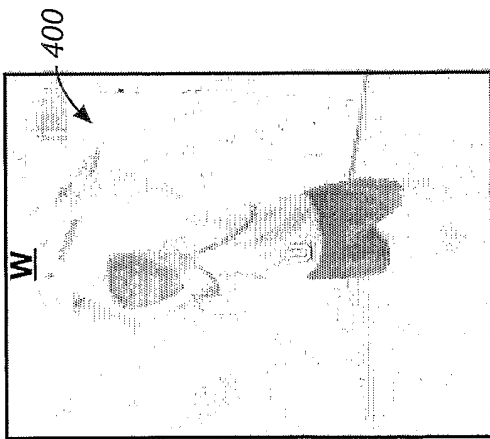

FIG. 15G

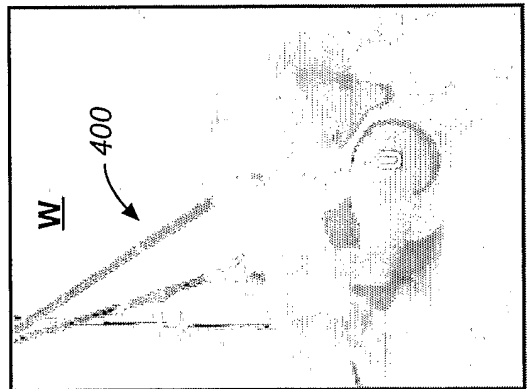

FIG. 15H

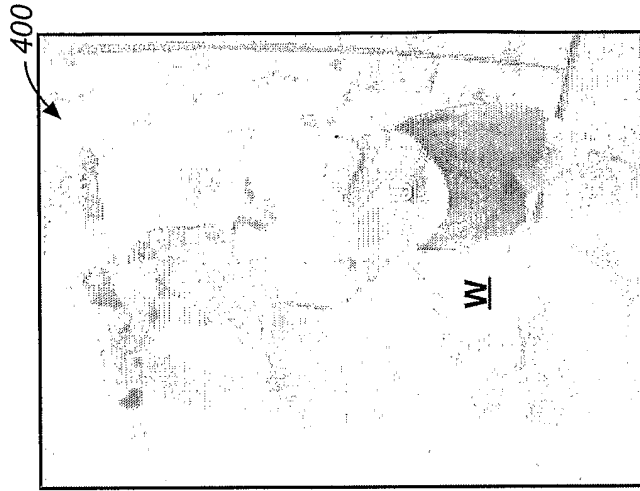

FIG. 15I

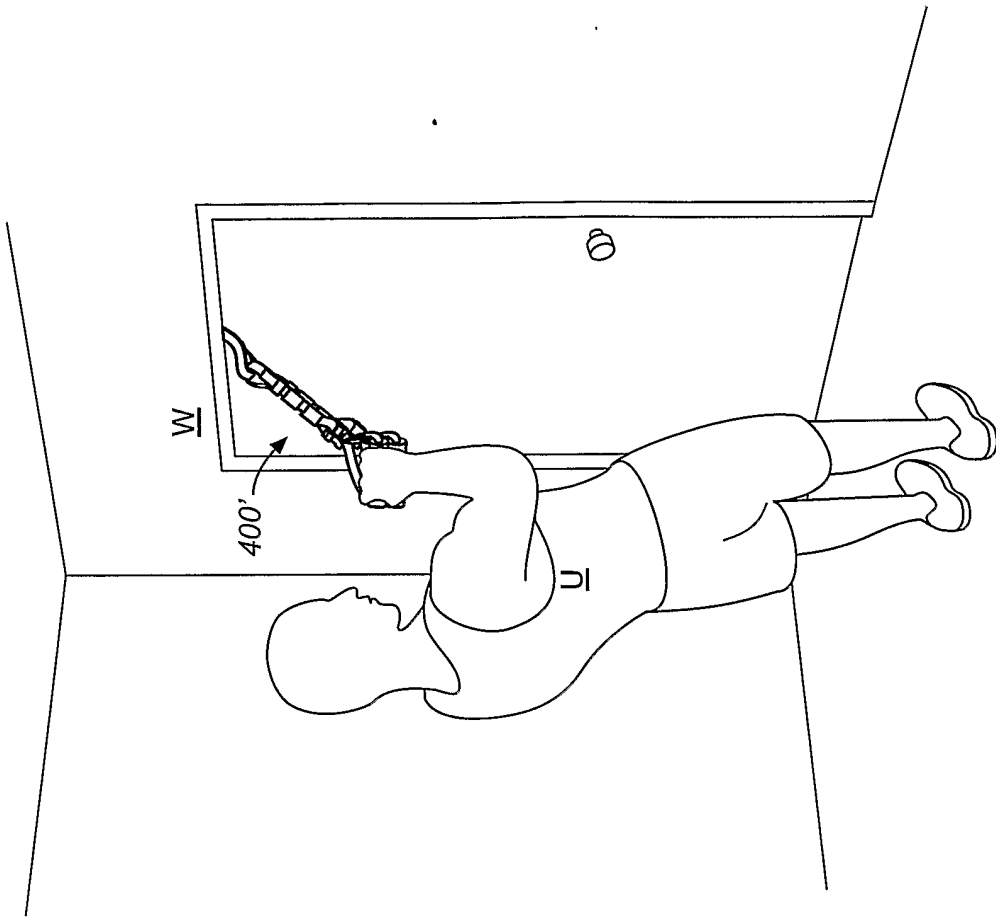

FIG. 16B

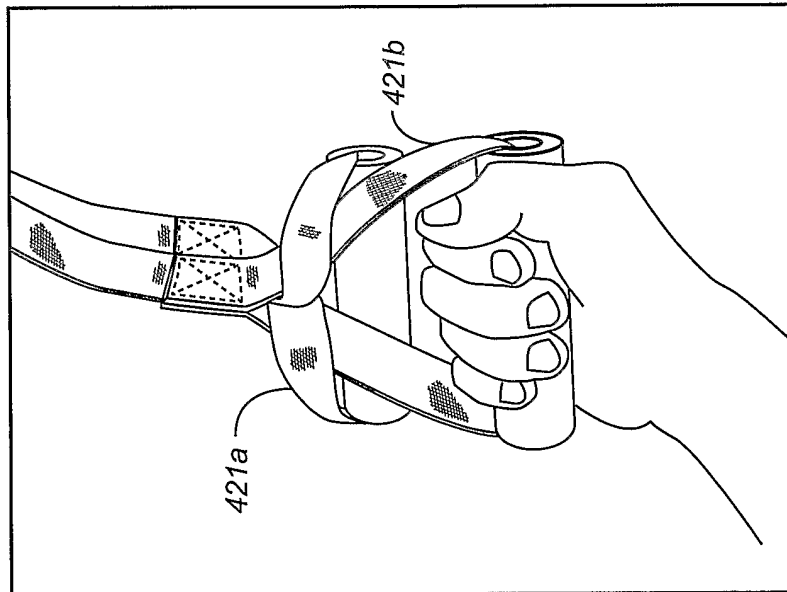
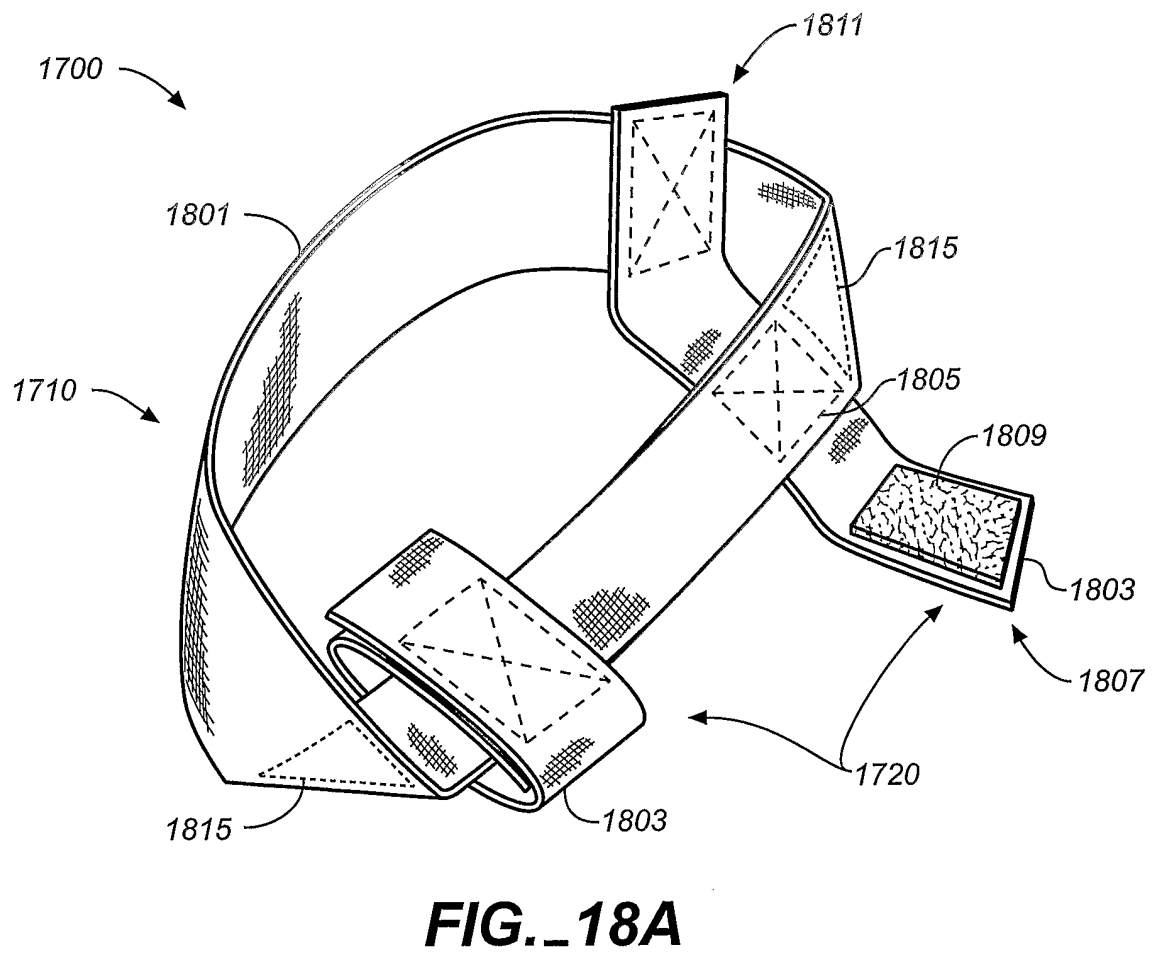
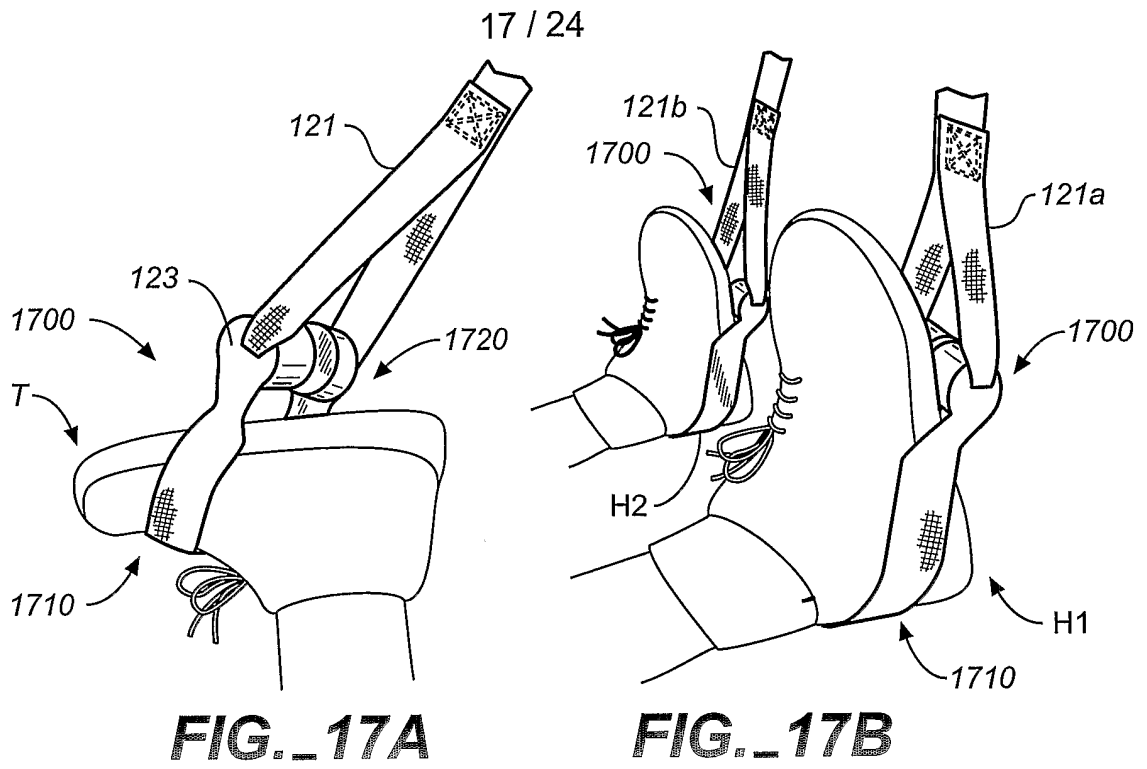

FIG. 16A



18 / 24

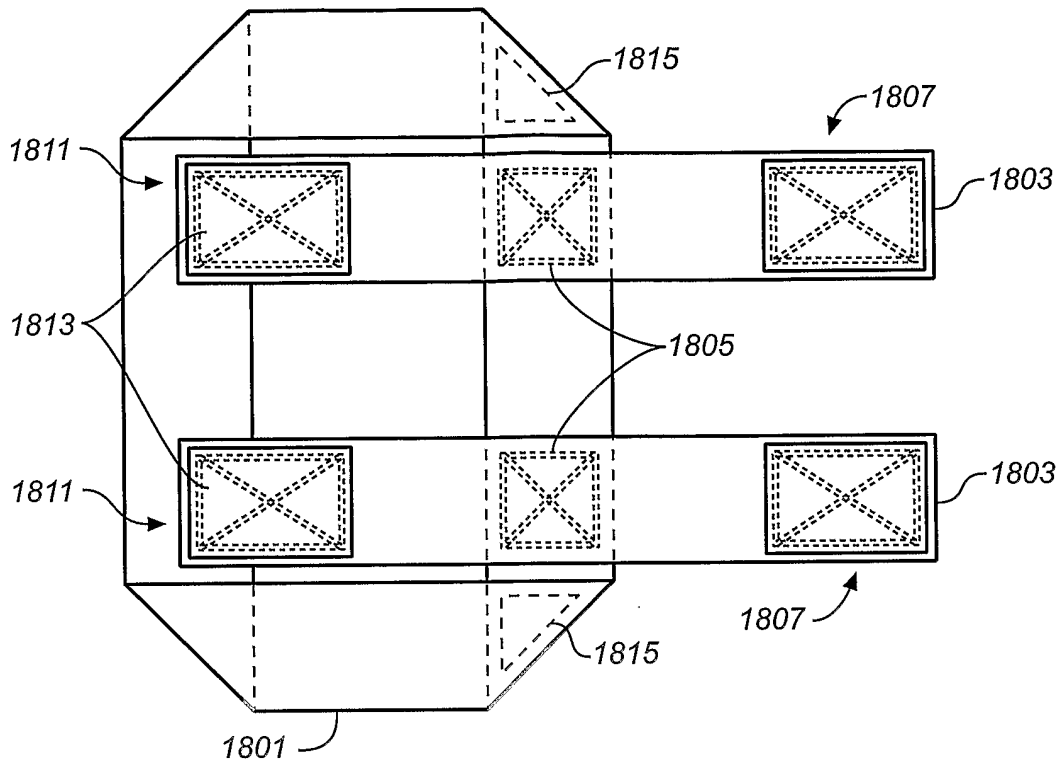

FIG. 18B

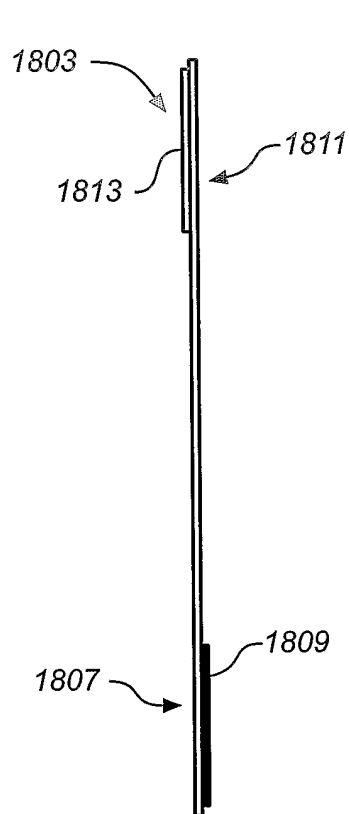

FIG. 18C

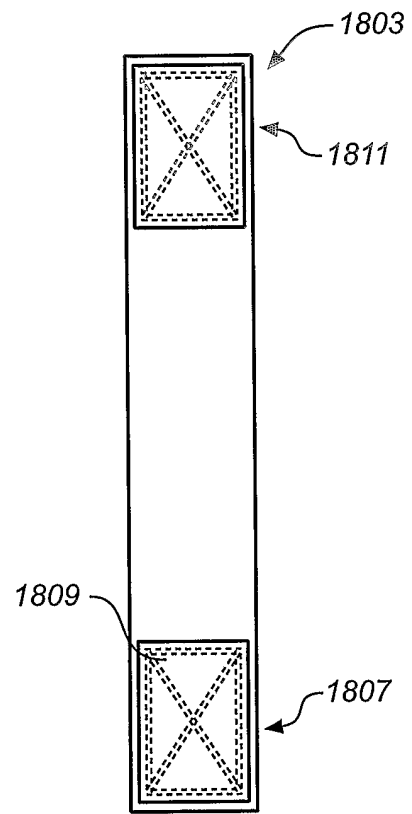

FIG. 18D

19 / 24

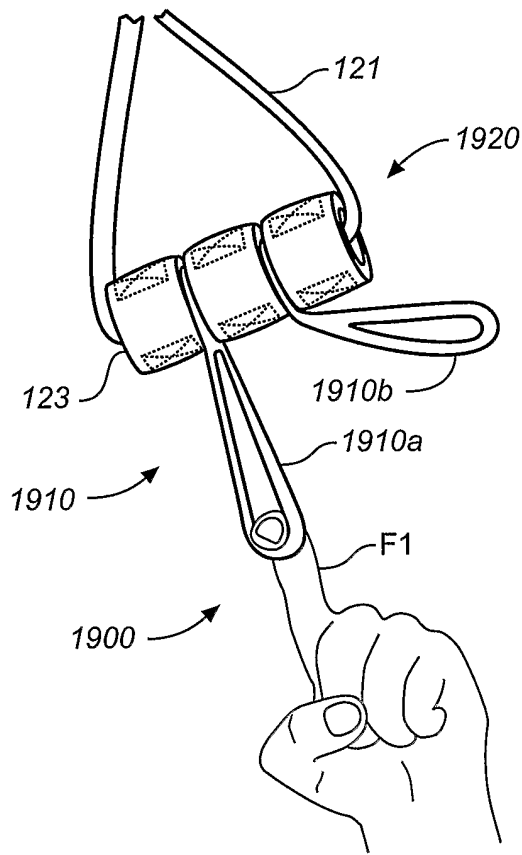

FIG._19A

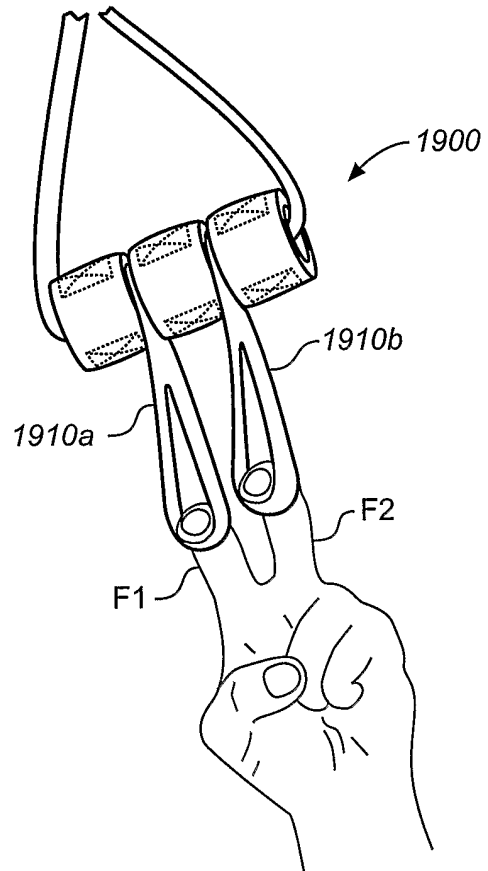

FIG._19B

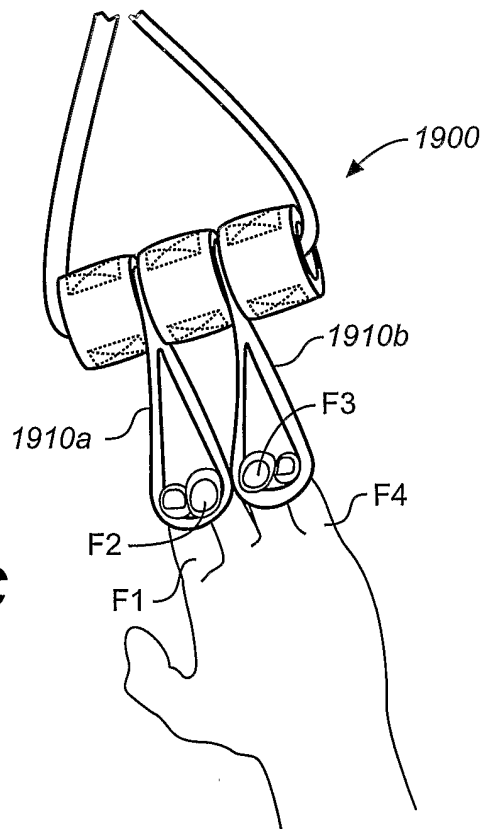

FIG._19C

20 / 24

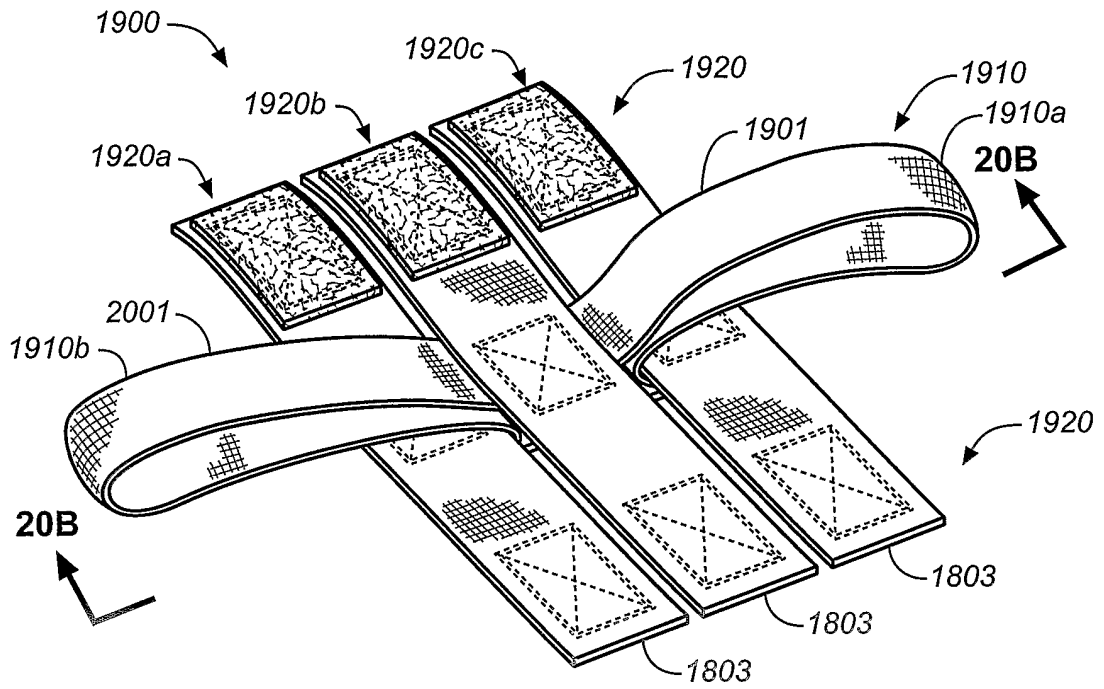

FIG. 20A

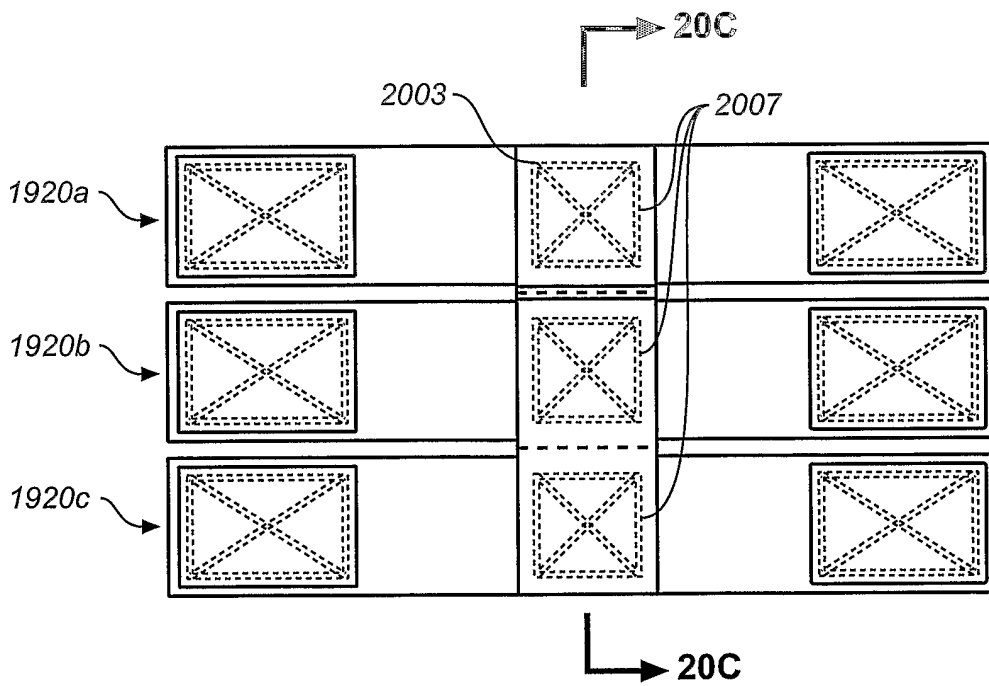

FIG. 20B

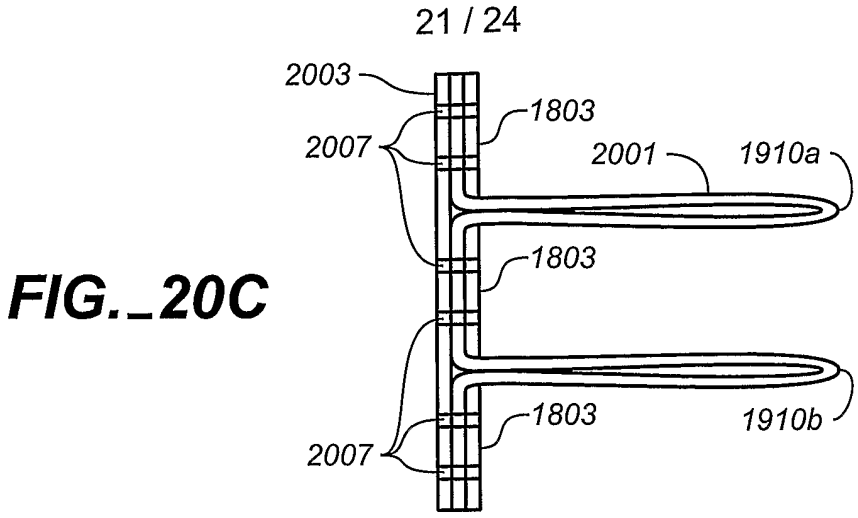

FIG. 20C

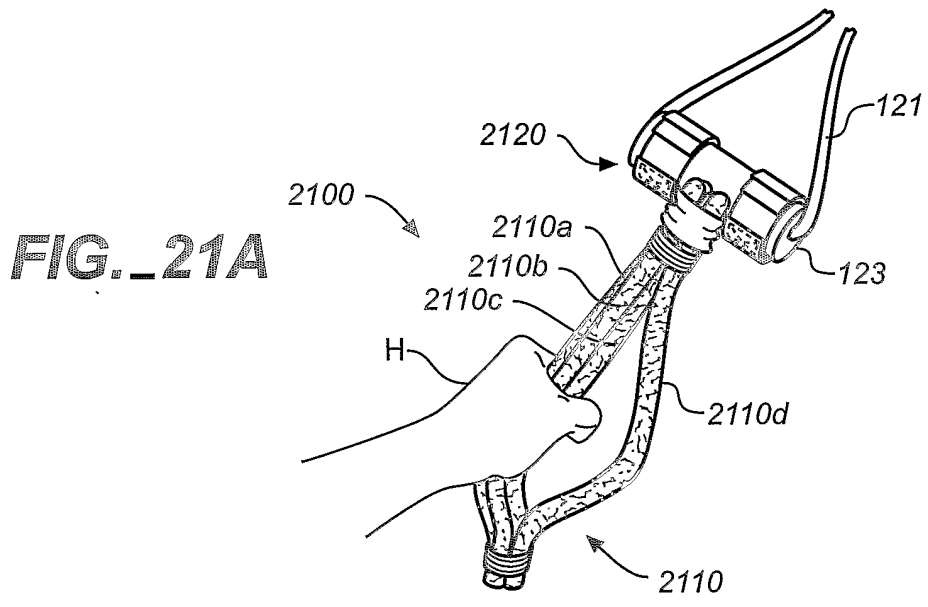

FIG. 21A

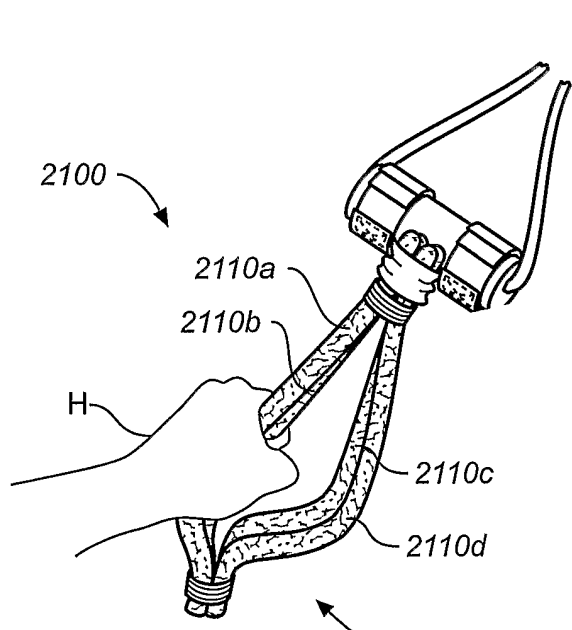

FIG. 21B

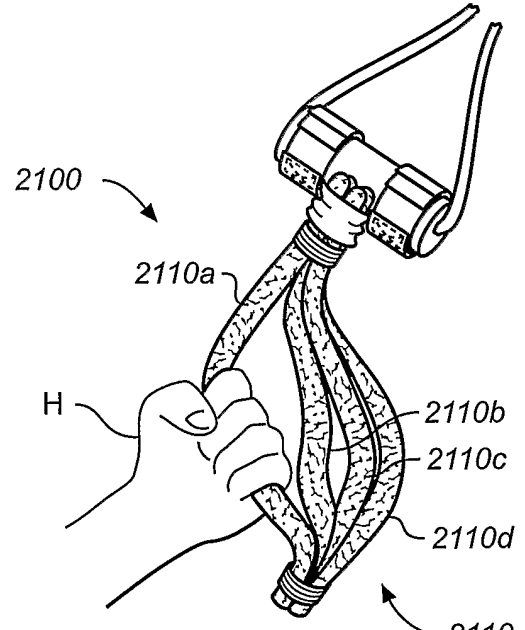

FIG. 21C

22 / 24

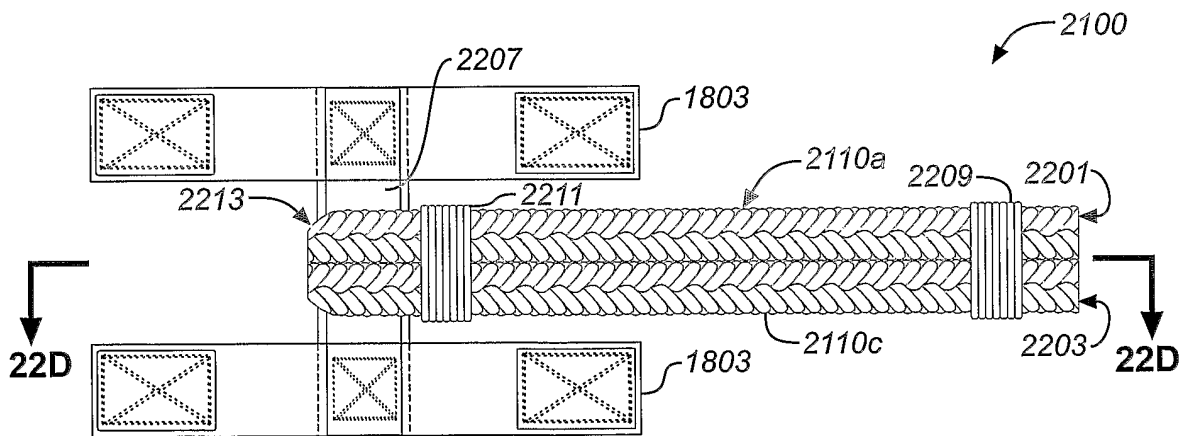
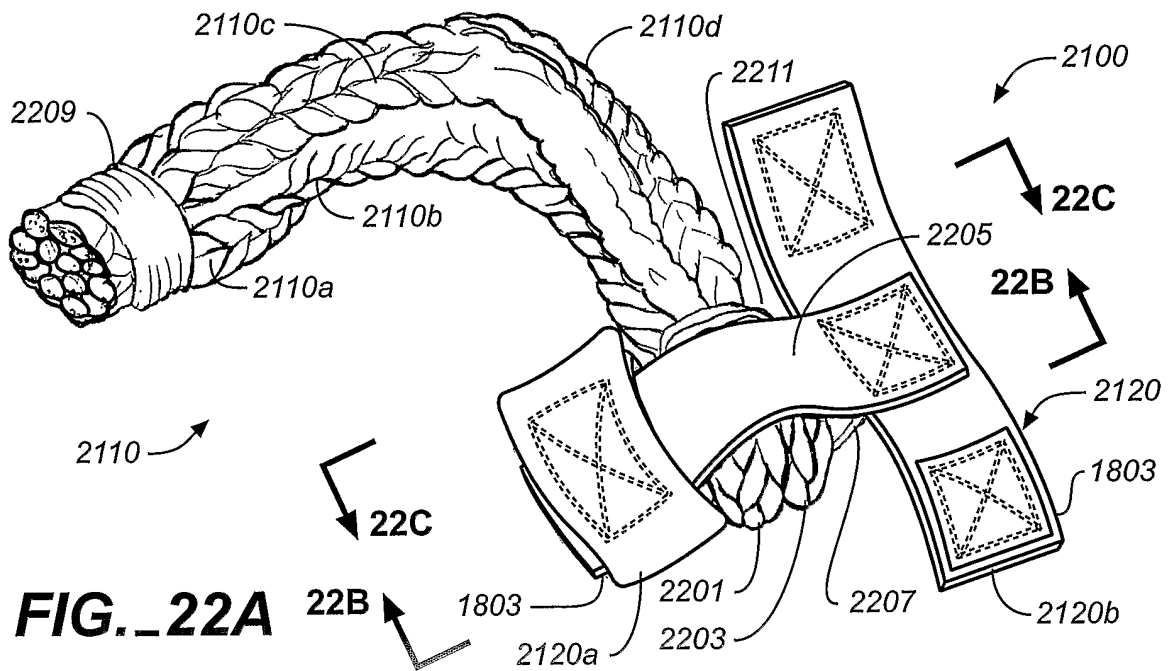

FIG. 22B

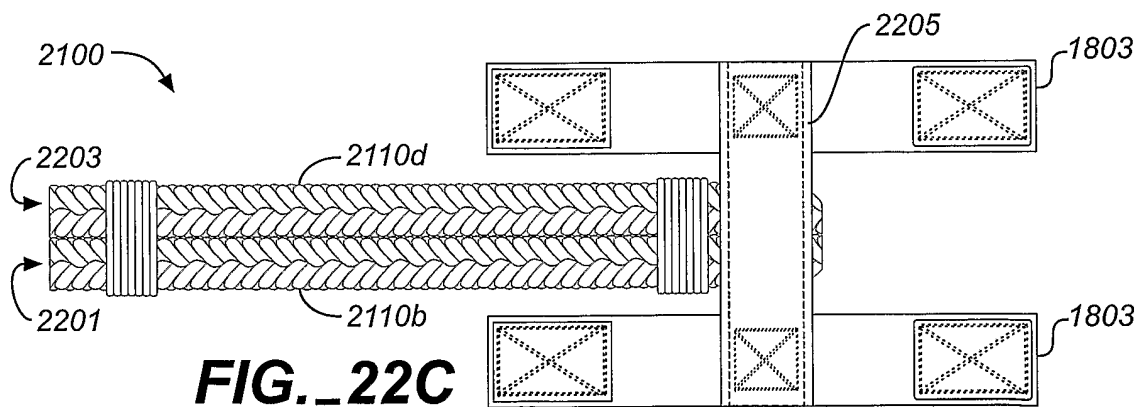

FIG. 22C

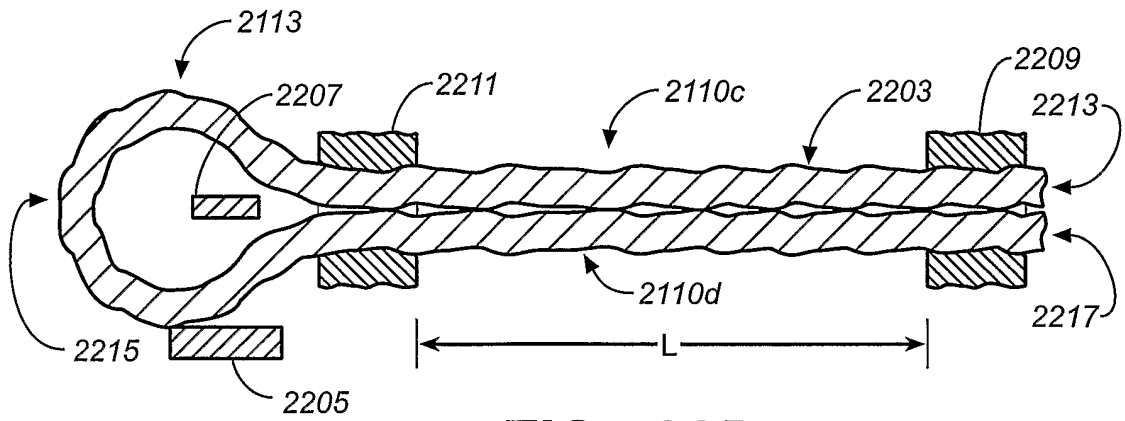

FIG. 22D

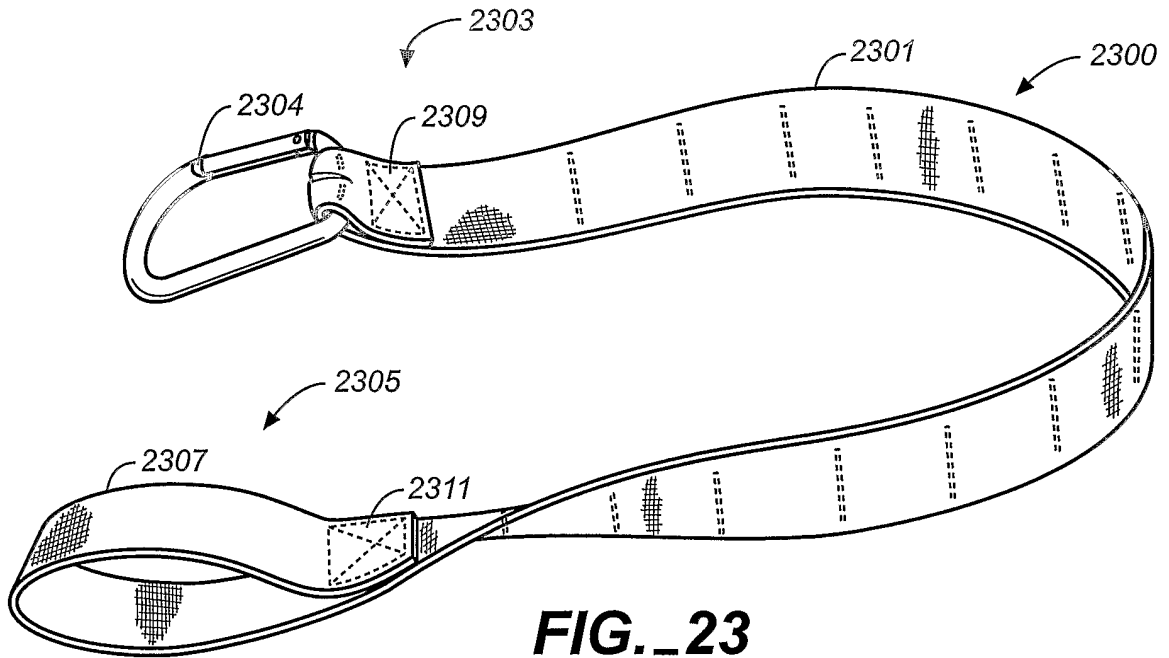

FIG. 23

24 / 24

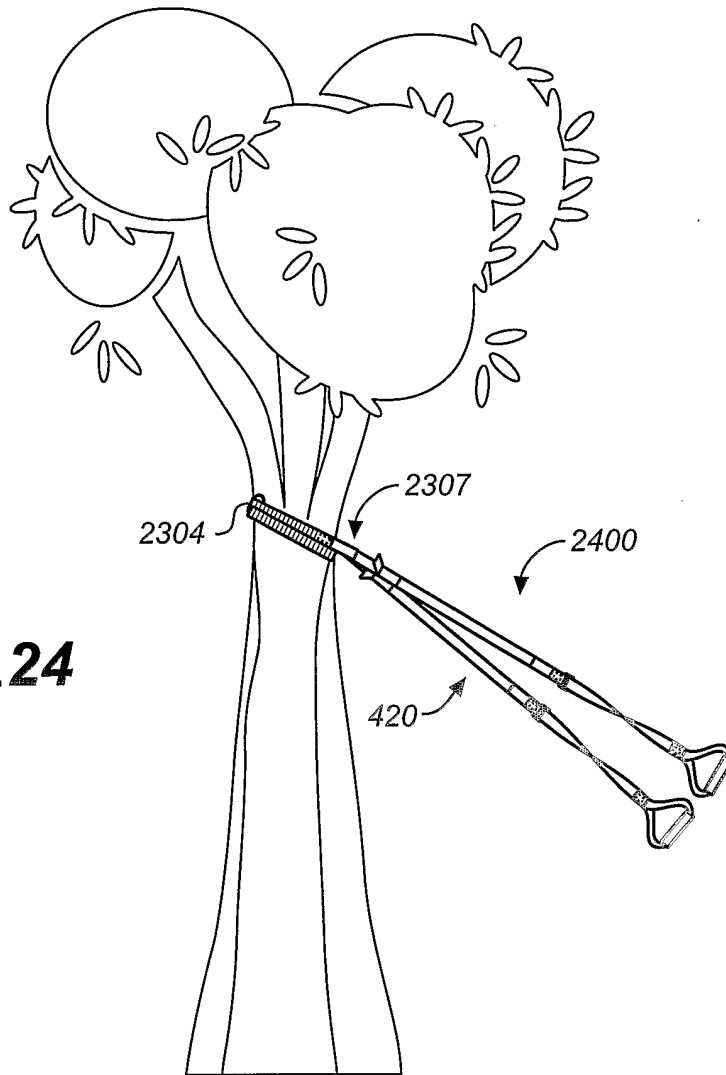

FIG. 24

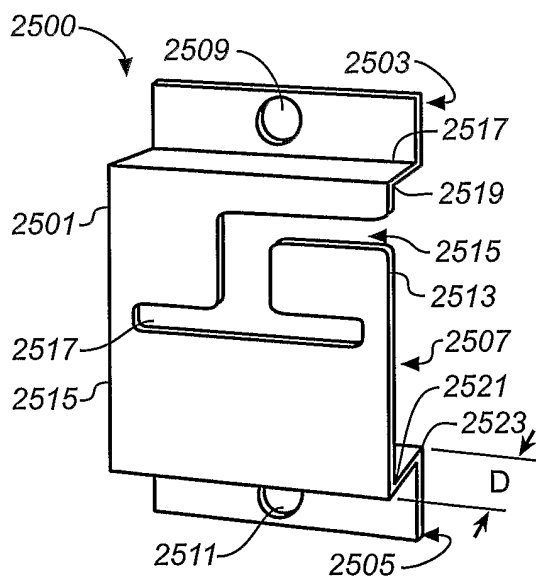

FIG. 25

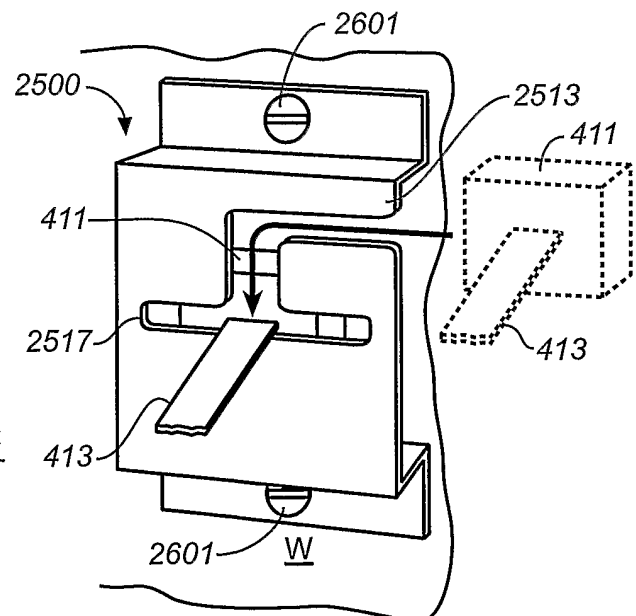

FIG. 26