



(12) **EUROPEAN PATENT APPLICATION**

(88) Date of publication A3:  
**21.03.2007 Bulletin 2007/12**

(51) Int Cl.:  
**B65B 35/14 (2006.01) B65B 43/18 (2006.01)**

(43) Date of publication A2:  
**06.04.2005 Bulletin 2005/14**

(21) Application number: **04023023.7**

(22) Date of filing: **28.09.2004**

(84) Designated Contracting States:  
**AT BE BG CH CY CZ DE DK EE ES FI FR GB GR HU IE IT LI LU MC NL PL PT RO SE SI SK TR**  
 Designated Extension States:  
**AL HR LT LV MK**

(72) Inventors:  
 • **Shigenaga, Nobuyuki Iwakuni-shi Yamaguchi (JP)**  
 • **Koga, Shoichi Iwakuni-shi Yamaguchi (JP)**

(30) Priority: **30.09.2003 JP 2003339056**

(71) Applicant: **Toyo Jidoki Co., Ltd. Tokyo (JP)**

(74) Representative: **Schubert, Siegmur Patentanwälte Dannenberg Schubert Gudel Grosse Eschenheimer Strasse 39 60313 Frankfurt (DE)**

(54) **Bag supplying apparatus for a bag-filling packaging machine**

(57) A bag supplying apparatus for a bag-filling packaging machine, including a vibrating feeder that involves a trough (6) in which bags are placed in a cascade fashion and a vibration driver (7) which vibrates the trough (6) so as to cause the bags (W0) to be conveyed forward, a

positioning stopper (2) provided at a final end of a conveying path of the bags so that the tip end of a leading bag (W1) being conveyed comes into contact with the stopper (2), and a suction disk (3) that suction-chucks and lifts a bag positioned by the position stopper (2) and feeds the bag to another location.

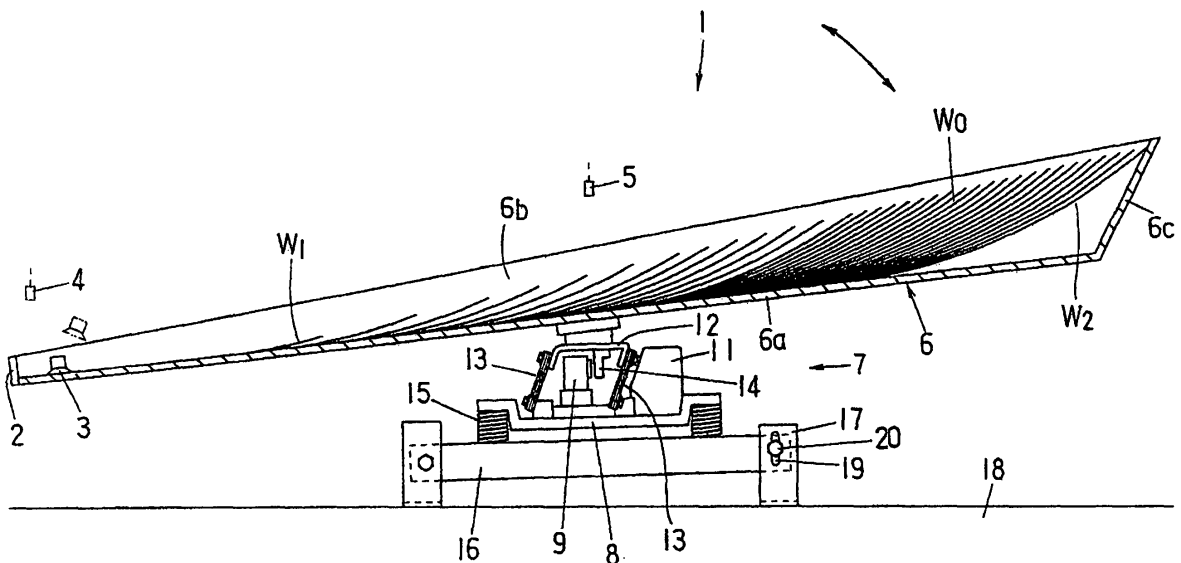

**FIG. 1**



DOCUMENTS CONSIDERED TO BE RELEVANT			
Category	Citation of document with indication, where appropriate, of relevant passages	Relevant to claim	CLASSIFICATION OF THE APPLICATION (IPC)
D,A	JP 01 120204 A (ISEKI AGRICULT MACH) 12 May 1989 (1989-05-12) * abstract *		INV. B65B35/14 B65B43/18
D,A	JP 03 117411 A (ISEKI AGRICULT MACH) 20 May 1991 (1991-05-20) * abstract *		
D,A	JP 10 194238 A (GEN PACKER CO LTD) 28 July 1998 (1998-07-28) * abstract *		
A	US 3 673 759 A (AYRES RICHARD H ET AL) 4 July 1972 (1972-07-04) * abstract; figure 1 *		
A	US 2 817 936 A (PETERSON WILLIAM R) 31 December 1957 (1957-12-31) * column 6, line 59 - column 7, line 7; figure 1 *		
A	US 4 537 015 A (INGLETT JR WILFRED L [US] ET AL) 27 August 1985 (1985-08-27) * the whole document *		
The present search report has been drawn up for all claims			TECHNICAL FIELDS SEARCHED (IPC)
			B65B
Place of search		Date of completion of the search	Examiner
Munich		8 February 2007	Ungureanu, Mirela
CATEGORY OF CITED DOCUMENTS			
X : particularly relevant if taken alone Y : particularly relevant if combined with another document of the same category A : technological background O : non-written disclosure P : intermediate document		T : theory or principle underlying the invention E : earlier patent document, but published on, or after the filing date D : document cited in the application L : document cited for other reasons ..... & : member of the same patent family, corresponding document	

**ANNEX TO THE EUROPEAN SEARCH REPORT  
ON EUROPEAN PATENT APPLICATION NO.**

EP 04 02 3023

This annex lists the patent family members relating to the patent documents cited in the above-mentioned European search report. The members are as contained in the European Patent Office EDP file on  
The European Patent Office is in no way liable for these particulars which are merely given for the purpose of information.

08-02-2007

Patent document cited in search report		Publication date	Patent family member(s)	Publication date
JP 1120204	A	12-05-1989	JP 2643195 B2	20-08-1997
JP 3117411	A	20-05-1991	JP 2932527 B2	09-08-1999
JP 10194238	A	28-07-1998	NONE	
US 3673759	A	04-07-1972	CA 943926 A1	19-03-1974
			DE 2055217 A1	11-11-1971
			FR 2092260 A5	21-01-1971
			GB 1286947 A	31-08-1972
			JP 49022190 B	06-06-1974
US 2817936	A	31-12-1957	NONE	
US 4537015	A	27-08-1985	NONE	