



(51) International Patent Classification:

E05B 65/00 (2006.01) *E06B 3/48* (2006.01)
E05C 9/04 (2006.01) *E05B 55/12* (2006.01)
E05B 15/10 (2006.01) *E05B 15/02* (2006.01)

(21) International Application Number:

PCT/EP2012/062021

(22) International Filing Date:

21 June 2012 (21.06.2012)

(25) Filing Language:

English

(26) Publication Language:

English

(30) Priority Data:

MI2011A 001442 29 July 2011 (29.07.2011) IT

(71) Applicant (for all designated States except US): **PREFER COMMERCIALE S.R.L.** [IT/IT]; Via Fratelli Cervi, 63, I-20023 Cerro Maggiore (Milano) (IT).

(72) Inventor; and

(75) Inventor/Applicant (for US only): **FINARDI, Ivo** [IT/IT]; Viale Sempione, 21/31, I-20020 Arese (Milano) (IT).

(74) Agent: **PETRUZZIELLO, Aldo**; c/o Racheli S.R.L., Viale San Michele del Carso 4, I-20144 Milano (IT).

(81) Designated States (unless otherwise indicated, for every kind of national protection available): AE, AG, AL, AM,

AO, AT, AU, AZ, BA, BB, BG, BH, BR, BW, BY, BZ, CA, CH, CL, CN, CO, CR, CU, CZ, DE, DK, DM, DO, DZ, EC, EE, EG, ES, FI, GB, GD, GE, GH, GM, GT, HN, HR, HU, ID, IL, IN, IS, JP, KE, KG, KM, KN, KP, KR, KZ, LA, LC, LK, LR, LS, LT, LU, LY, MA, MD, ME, MG, MK, MN, MW, MX, MY, MZ, NA, NG, NI, NO, NZ, OM, PE, PG, PH, PL, PT, QA, RO, RS, RU, RW, SC, SD, SE, SG, SK, SL, SM, ST, SV, SY, TH, TJ, TM, TN, TR, TT, TZ, UA, UG, US, UZ, VC, VN, ZA, ZM, ZW.

(84) Designated States (unless otherwise indicated, for every kind of regional protection available): ARIPO (BW, GH, GM, KE, LR, LS, MW, MZ, NA, RW, SD, SL, SZ, TZ, UG, ZM, ZW), Eurasian (AM, AZ, BY, KG, KZ, RU, TJ, TM), European (AL, AT, BE, BG, CH, CY, CZ, DE, DK, EE, ES, FI, FR, GB, GR, HR, HU, IE, IS, IT, LT, LU, LV, MC, MK, MT, NL, NO, PL, PT, RO, RS, SE, SI, SK, SM, TR), OAPI (BF, BJ, CF, CG, CI, CM, GA, GN, GQ, GW, ML, MR, NE, SN, TD, TG).

Declarations under Rule 4.17:

— of inventorship (Rule 4.17(iv))

Published:

— with international search report (Art. 21(3))

(54) Title: SPRING CLOSURE SYSTEM FOR AN ENTRANCE DOOR OF A SECTIONAL DOOR

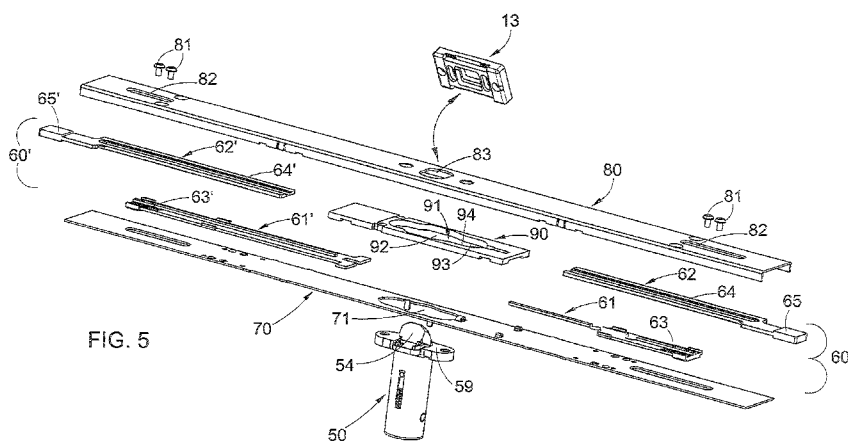

(57) Abstract: A description is given of a closure system for an entrance door formed in a sectional door (S), the entrance door being constituted by a plurality of superimposed panels (P) reciprocally articulated like the corresponding sections of the sectional door (S), wherein a lock (L) is suitable for being assembled on a first panel (PI) of the entrance door in order to block the entrance door with respect to the sectional door, said lock (L) acting on vertical shaft segments (6) of a composite shaft in order to actuate a plurality of spring bolts (50) suitable for blocking respective panels (P) of the entrance door to the corresponding sections of the sectional door (S).



WO 2013/017334 A1

SPRING CLOSURE SYSTEM FOR AN ENTRANCE DOOR OF A SECTIONAL DOOR

DESCRIPTION

5

The object of the present invention is a spring closure system for an entrance door of a sectional door.

10

Sectional doors, which are used particularly for the closure of garages and similar premises, are made up of a plurality of superimposed sections which are reciprocally articulated along horizontal axes, so that the sectional door, when it is in the lowered condition, lies substantially in a vertical plane which blocks the entrance of the premises, when it is in the raised condition it lies substantially in a horizontal plane parallel to the ceiling of the premises, and in the passage from one to the other of these conditions it follows a curved trajectory, which is made possible by the articulations between the different sections.

15

These sectional doors, in view of their function, have usually a considerable extension, and it is uselessly burdensome to raise the entire sectional door when it is necessary to allow only the passage of one or more persons. For this reason, in certain sectional doors an entrance door of small dimensions is formed, intended to be opened to allow the passage of persons, without raising the whole sectional door.

20

However, since the entrance door must have a height proportioned to the height of the persons, it has to extend for several sections of the sectional door, and therefore must also be made up of reciprocally articulated panels, in order to be able to follow the curved trajectory of movement of the sectional door.

25

In most of the known embodiments the entrance door is closed, with respect to the sectional door wherein it is formed, by means of an ordinary lock, which allows blocking of only one of the panels of the entrance door with respect to the corresponding section of the sectional door. However this mode of operation leads to a serious problem, because each panel of the entrance door can be correctly restrained only on one side of hinging by a vertical articulation with respect to the corresponding section of the sectional door, while on the side of opening a single panel of the entrance door is stably fixed in the closed position by the lock, while all the other panels of the entrance door are

30

35

restrained by only the panel closed with lock via repeated articulations so that, due to the inevitable backlash of the articulations, the various panels of the entrance door are not restrained in a stable manner. This makes the entrance door unappealing to the user, yet at the same time reduces the security thereof, because the instability of the panels facilitates the forcing of a similar entrance door.

In certain known, more developed, embodiments the entrance door is provided with a lock which blocks the panel whereon it is installed, as well as an upper latch and a lower latch. The mechanisms of these entrance doors have some disadvantages, and moreover the efficacy of the closure is not totally satisfactory.

Moreover in some known embodiments the mechanisms of the entrance door which has been opened are not presented as ready for a simple re-closure of the door without requiring a particular manoeuvre, in other words they allow the opening only from the exterior of the door.

Italian patent application no. TO2010A000644 in the name of the same Applicant, not yet published, describes a system of closure for an entrance door formed in a sectional door, which solves part of the problems disclosed above by allowing the blocking of several panels of the entrance door to corresponding sections of the sectional door.

However the assembly of this system of closure requires long and complex operations to be performed on the entrance door and, in an assembled condition, has a certain bulk on the edge of the door, which makes it unaesthetic.

Moreover this closure system has to be designed for the particular sectional door whereon it has to be installed, not allowing an adaptability in situ on the basis of the dimensions of the sections of the door and of the panels of the entrance door.

The object of the invention is that of eliminating the disadvantages of the known systems, ensuring for the entrance door a stable and resistant closure of all the panels whereof it is composed, likewise guaranteeing that, once it has been opened, it is presented as ready for being closed again without requiring any particular manoeuvre.

Another object of the invention is that of providing such a closure system which has a limited bulk on the edge of the entrance door and therefore is aesthetically pleasing.

Yet another object of the invention is that of allowing the adaptability to panels of the entrance door and sections of the sectional door of different height.

5 Again another object of the invention is that of allowing the assembly of the closure system indifferently on entrance doors with right or left opening.

Last but not least an object of the present invention is that of providing such a closure system which is simple and economical to manufacture and easy to assemble by the user.

10 These objects are achieved by the closure system for an entrance door of a sectional door which has the features listed in the annexed independent claim 1.

Advantageous embodiments of the invention are disclosed by the dependent claims.

Substantially the closure system according to the invention, wherein the entrance door is
15 made up of a plurality of superimposed panels P reciprocally articulated along horizontal axes situated at the axes of articulation of the corresponding sections of the sectional door S, wherein each panel P of the entrance door is articulated along a vertical axis, on a side of hinging of the entrance door, to a corresponding section of the sectional door, and wherein a lock of the closure system is suitable for being mounted on a first panel of the
20 entrance door to block the entrance door with respect to the sectional door, comprises operatively vertical shaft segments which can be moved, through the action of the lock, between an opening position and a closure position, said shaft segments terminating at their distal ends, in the closure position, at said axes of articulation of the first panel; at least for some other panels of the entrance door vertical shaft segments are provided,
25 coaxial with said shaft segments of the first panel, said vertical shaft segments being connected to means of blocking of the corresponding panel with respect to the corresponding section of the sectional door, the shaft segments for each panel terminating at their ends, in the closure position, at said axes of articulation of the same panel, and the vertical shaft segments of each panel being aligned with the vertical shaft
30 segments of the adjacent panels, so that the whole of all the shaft segments for the various panels of the entrance door constitutes a composite shaft which is interrupted at the articulations between the panels; said blocking means consist of a spring bolt, whose containment casing is housed in the edge of the entrance door and comprising an oscillating bolt head engaged with a stop block positioned on the edge of a section of the
35 sectional door opposite the corresponding panel of the entrance door, said oscillating bolt head being normally in blocking position and being able to be released by movement of

the corresponding shaft segment of the composite shaft by actuation of the handle of said lock.

Further features of the invention will be made clearer by the following detailed description, referred to one of its embodiments purely by way of a non-limiting example illustrated in the accompanying drawings, in which:

Figure 1 is a frontal view in closed condition of a sectional door, wherein an entrance door for persons is formed;

Figure 2 is a perspective view of a lock and of a corresponding composite shaft device according to the present invention;

Figure 3 is a view of the lock of Figure 2 in a direction perpendicular to the edge of the entrance door, i.e. parallel to the plane of the same;

Figure 4 illustrates in a frontal view the system of gears which transmits the movement from the lock to the composite shaft;

Figure 5 illustrates in blown-up perspective a composite shaft segment with its containment casing and the blocking means present in each panel, as well as a stop block to be applied on the jamb of the sectional door, shown in a different perspective for greater clarity;

Figure 6 illustrates the components of Figure 5 in an assembled condition, without the cover of the containment casing, with the composite shaft segment in a first position;

Figure 7 is a view like Figure 6, with the composite shaft element in a second position;

Figure 8 is a side profile view taken from the left side of Figure 7;

Figure 9 is a section taken along the plane IX-IX of Figure 7;

Figures 10, 11 and 12, are sections taken along plane A-A of Figure 6 or B-B of Figure 7 with some parts on view, illustrating the blocking means in different positions with respect to the corresponding stop block provided on the jamb of the sectional door, with which they co-operate;

Figure 13 is a median section of the blocking means in the position of Figure 11.

Referring for the time being to Figure 1, the reference S denotes a sectional door, whereof four sections are shown, and the reference P denotes an entrance door, which is formed in the four sections shown of the sectional door S, and therefore is in turn composed of four panels. At the aperture formed for the entrance door P, the corresponding sections of the sectional door S have frame elements K1, K2, K3 and K4. At the frame elements K1 the panels of the entrance door P are articulated to the corresponding sections of the sectional door S, while at the other frame elements K2, K3

and K4 the opening of the entrance door P takes place. A lock L is applied to a first panel of the entrance door P to allow the closure and the opening of the entrance door P.

5 According to the invention the intent is that the closure by lock of the entrance door P takes place at a plurality of the frame elements K3, and preferably at all these frame elements.

10 Referring to Figures 2 to 4, the lock L installed on a first panel P1 of the entrance door has an operative member 1 which can be moved in a horizontal direction, parallel to the plane of the door, and a gears device D is provided, such as that shown by way of an example in Figure 4, which transforms the horizontal movement of the operative member 1 into a movement in vertical direction in opposite ways of two shaft segments 6. The gears device D given as an example comprises a double rack 2, connected to the operative member 1 of the lock L, and meshing with pinions 3 which in turn mesh with 15 cogged wheels 4 which actuate two racks 5 connected to the shaft segments 6.

In the closure condition of the lock L, the shaft segments 6 of the first panel P1 terminate, at their distal ends, at the horizontal articulations of the first panel P1 with respect to the other panels of the entrance door, denoted, for reasons of simplicity, again 20 by reference P. Therefore, in this condition, the presence of the shaft segments 6 does not obstruct the relative rotation of the panels P, which has to be able to take place freely during the movements of the sectional door S.

For their part the other panels P of the entrance door also have vertical shaft segments, denoted by the same reference numeral 6, coaxial with said shaft segments 6 of the first 25 panel, and the shaft segments of each panel P terminate at their ends, in the closure position of the lock L, at the axes of articulation of the same panel P, and the vertical shaft segments 6 of each panel P are axially aligned with the vertical shaft segments 6 of the adjacent panels. In this way the whole of all the shaft segments 6 of the various panels P of the entrance door constitutes a composite shaft, which is interrupted at the 30 articulations between the panels, so as not to obstruct the relative rotation between the panels P, but so as to behave like a continuous shaft in the lowered condition of the sectional door S.

In the above there is generic mention for reasons of simplicity of shaft segments 6 of the 35 composite shaft. In actual fact, as will be explained in greater detail herein below, the

shaft segments 6 are in turn broken down into several elements in order to simplify the assembly and the actuation of the closure system according to the invention.

5 Referring now in particular to the blown-up view of Figure 5 and to the successive drawings, the structure and the functioning of a shaft segment 6 and of the relative blocking means B are described in greater detail.

As can be seen in Figure 5, a segment 6 of the composite shaft is split into two parts 60, 60', each one of which, according to the invention, is in turn broken down into two
10 further elements, which will also be referred to as latches, 61, 62 and 61', 62', respectively.

These latches are placed on a flat base 70, appropriately perforated for the purposes which are to be mentioned herein below, closed by a cover 80, also provided with
15 appropriate holes.

The latches 61, 61', which are also to be referred to as fixed latches, are restrained by slotting or with other means to a central plate 90, which has a shaped aperture 91, which is arranged in alignment with a corresponding shaped hole 71 provided in the base plate
20 70, through which passes the head or catch 54 of the blocking means B, constituted in particular by a bolt 50, whose structure will be explained in greater detail herein below.

On the fixed latches 61, 61' are applied the mobile latches 62, 62', which can slide thereon in order to allow a regulation of the length of the corresponding assembled latch 60, 60' and therefore an adaptation to panels P of the entrance door of different height.
25 The latches 61, 62 and 61', 62' remain engaged in the required position by means of pairs of teeth provided on the respective opposite faces, whereof those provided on the fixed latches 61, 61' are just visible and denoted by reference numerals 63, 63'. The blocking of these elements taking place by means of pairs of screws in 81, which traverse respective slots 82 provided in the cover 80, and a respective longitudinal slit 64, 64'
30 provided in the mobile latches 62, 62', in order to screw in corresponding holes formed in the fixed latches 61, 61'.

In this way the components 61, 62, 61', 62' and 90 constitute a single segment of the composite shaft of actuation of the closure system according to the invention.

35

The aforesaid components are closed between the base 70 and the cover 80 which form a casing which is attached by means of screws to the edge of the entrance door P.

5 The cover 80 of the casing also has a hole 83 at the holes 91 and 71 provided respectively in the plate 90 and in the base 70, for the passage of the bolt head 51.

10 The mobile latches 62, 62' have the ends 65, 65' projecting from the containment casing misaligned so as to be placed on one side of the casing, rather than centrally thereto, in order to be situated on the inner side of the edge of the entrance door in assembled position, and in this way to allow an easy opening of the sectional door.

Such a configuration of the latches 60, 60' makes the closure reversible, allowing in the phase of installation an assembly on door with opening on the right or left.

15 Figures 6 to 9 show a casing of containment of the components of Figure 5 for door with opening on the right as shown in Figure 1, and positioned at one of the panels of the entrance door P placed below the one carrying the lock L, or on the same panel P1 carrying the lock L, when the blocking means B are placed below the lock, as shown in the drawings.

20 Figure 6 shows the position of the latches, in other words of the composite shaft segment in the closed door condition, with the bolt 50 blocked, while Figure 7 shows the configuration of the latches in the phase of opening of the entrance door, i.e. with the bolt unblocked, as will be explained in greater detail herein below.

25 In practice the condition of closed door of Figure 6, in other words of bolt blocked, corresponds to the position of the members of actuation of the lock shown in Figure 4. By starting from this position and actuating the operative member 1 in the direction of the arrow, in order to translate the rack 2 in the same direction, the composite shaft segments 6 are moved away one from the other as indicated by the arrows. More
30 particularly, the lower segment 6 is moved downwards and moves in the same direction all the other composite shaft segments provided in the panels situated below the one carrying the lock L. Therefore the latches shown in Figure 6 are moved downwards, causing the release of the bolt (Figure 7) as will be described in greater detail herein
35 below.

Naturally the same occurs for the composite shaft segments, in other words the latches positioned in the panels situated above the one containing the lock L, which are moved upwards and function in the same way, the latches in this case being arranged in an inverted position with respect to those of Figures 6 and 7.

5

The functioning of the blocking bolt will now be explained in greater detail, also referring to Figures 10 to 13.

As can be seen in Figures 10 to 13, the bolt 50 comprises a tubular casing 52 which is inserted in the edge of the entrance door and encloses the entire mechanism of actuation of the bolt. More particularly, in the casing 52 a slider 53 is placed, acting as an actual bolt, carrying at the end the bolt head or catch 54, mounted oscillating around a pin 55, under the action of a spring 56 (Figure 13), which tends to hold the head 54 in the position of blocking shown in Figures 11 and 13.

15

The slider 53 is pushed in a rest position, corresponding to that of blocking of the bolt head 54, by a spring 57.

The rest position of the slider 53, in other words the blocking position of the bolt head 54, is ensured by a tooth 41 provided on the slider which engages in a corresponding seat 42 of an L-shaped balancing lever 43, hinged in 44 to the casing 52. A longer arm 45 of the lever 43 extends longitudinally to the interior of the casing 52 where to it is hinged, while the shorter arm 46 projects laterally from the casing 52.

At the free end of the arm 45 of the lever 43, in addition to the fulcrum 44, a projection 47 is provided, oriented substantially parallel to the short arm 46 of the lever 43, against which acts a spring 48, suitable for holding the lever 43 normally engaged with the tooth 41, in position of blocking of the bolt.

It should be noted that the description of the lever 43 has been simplified for reasons of clarity. In actual fact the lever 43 is double and the short arms 46 are joined one to the other at the free ends, and the tooth 41 is double and is constituted by a transverse bar which goes to engage in the cavities 42 of the double lever. Likewise the projection 47 at the end of the arm 45 is constituted by a bar which joins the ends of the two arms of the double lever.

35

The projecting arm 46 of the lever 43 is positioned flush with the perforated plate 90 of the latch, inside the shaped aperture 91, which has a wider central section 92, wherein the projecting arm 46 of the L-shaped lever 43 (Figure 6) is freely housed and a narrower end section 93, defined by a cam profile 94 provided on an edge of the aperture 91, in the upper part of the plate 90 with reference to Figures 6 and 7.

A translation downwards of the latch or composite shaft segment, and in particular of the perforated plate 90, from the position of Figure 6 to that of Figure 7, causes the sliding of the cam profile 94 of the shaped hole 91 against the projecting arm 46 of the L-shaped lever 43, causing the withdrawal of this arm 46 inside the casing 52, and therefore an oscillation of the L-shaped lever 43 which disengages its seat 42 from the projection 41, releasing the bolt 50, and therefore allowing the mobility of the slider 53 in contrast to the action of the spring 57, as shown in Figure 12.

The perforated plate 90 is held in the rest position of Figure 6 by a spring 95, which acts between this plate and a fixed striker 59, made integral with the base plate 70 of the casing.

Referring in particular to Figures 10 to 12 the functioning of the bolt 50 is illustrated, which co-operates with a corresponding stop block 13 positioned on the jamb of the door, in other words on the edge of a section of the sectional door S opposite the corresponding panel P of the entrance door.

The stop block 13 has a housing 12 suitable for holding the bolt head 54, said housing 12 being defined on the outer side of opening of the entrance door P by a bevelled jut 11, against which the oscillating bolt head 54 abuts in conditions of closed door, in other words of blocked bolt (Figure 11). In this block condition it is not possible to open the entrance door P without actuating the handle of the lock L. In fact a possible push of the door in the direction of opening, i.e. of movement of the bolt 50 towards the left with respect to the stop block 13 of Figure 11, would cause the jamming of the bolt head 54 against the jut 11, any movement of the slider 53 being prevented by the engaging of the L-shaped lever 43 with the projection 41.

In order to be able to open the entrance door it is necessary to act on the handle of the lock L, from the inside or from the outside of the door, causing the withdrawal in the casing 52 of the L-shaped lever 43, and therefore its disengaging from the projection 41,

thus freeing the movement of the slider 53 which allows the withdrawal in the casing of the catch or bolt head 54, when the latter slides against the jut 11 of the stop block 13 in the phase of opening of the door (Figure 12).

5 The oscillating bolt head 54 is designed in such a way as to allow the superseding of the jut 11 of the stop block 13 in the phase of closure of the door with bolt blocked, as shown in Figure 10. In fact, by moving the entrance door close to the sectional door S, the bolt head 54, encountering the jut 11, oscillates around its fulcrum pin 55 in contrast to the return spring 56, until superseding this jut 11 and positioning in the housing 12 of the
10 stop block 13.

From what is disclosed the advantages of the closure system for entrance doors of a sectional door according to the invention appear clear, whose blocking means B or bolts 50 can be arranged at some, or preferably all, of the panels P of the entrance door,
15 ensuring secure blocking of the entrance door in a closed position.

The closure system according to the invention is easy to install, causing a minimal bulk on the edge of the entrance door, in that the casing 52 of each bolt 50 is housed inside the entrance door, from the edge whereof projects substantially only the bolt head 54, in
20 addition to the casing of containment of the latches, constituted by the base 70 and by the cover 80 which is strongly flattened.

The breaking down of the latches into fixed and mobile allows a regulation of the length of the same and therefore an adaptation to panels of the entrance door or sections of the
25 sectional door of different height.

Moreover the closure is of the reversible type, it being possible, in the installation phase, to assemble the latches in inverted position according to right or left opening of the entrance door.
30

Again, in the phase of closure, there is a greater resistance to forcing, in the case of break-in attempts, due to the jamming of the catch or latch head 54 against the jut 11 of the stop block 13.

35 Naturally the invention is not limited to the particular embodiment previously described and illustrated in the accompanying drawings, but instead numerous detail changes can

be made thereto, within the reach of the person skilled in the art, without thereby departing from the scope of the same invention as defined in the annexed claims.

CLAIMS

1. A closure system for an entrance door cut out into a sectional door (S), the entrance door being formed by a number of superimposed panels (P) mutually hinged along
5 horizontal axes lying in correspondence of the hinge axes of the corresponding sections of the sectional door (S), wherein each entrance door panel (P) is hinged along a vertical axis, at a hinge side (K1) of the entrance door, to a corresponding section of the sectional door, and wherein a lock (L) of the closure system is adapted to be mounted on a first entrance door panel (P1) to block the entrance door with respect to the sectional door,
10 characterized:
in that said lock (L) is operatively connected with vertical shaft segments (6) suitable for being displaced, by action of the lock (L), between an opening position and a closing position, said shaft segments (6) ending at their distal end portions, in the closing position, in correspondence of said hinge axes of the first panel (P1);
15 in that at least for some other panels (P) of the entrance door there are provided vertical shafts (6), coaxial with said shaft segments (6) of the first panel (P1), said vertical shaft segments (6) being connected to block means (B) intended to block the corresponding panel to the corresponding section of the sectional door, the shaft segments (6) of each panel (P) ending at their end portion, in the closing position, in correspondence of said
20 hinge axes of the same panel, and the vertical shaft segments (6) of each panel being aligned with the vertical shaft segments (6) of the adjacent panels, whereby the whole of all the shaft segments (6) for the various entrance door panels (P) forms a composite shaft which is interrupted in correspondence with the hinges among the panels; and
in that said block means (B) consist of a spring bolt (50), the containment envelope thereof (52) being housed in the rim of the entrance door and comprising an oscillating
25 bolt head (54) engaged with a stop member (13) placed in the rim of a section of the sectional door (S) opposite to the corresponding panel (P) of the entrance door, said oscillating bolt head (54) being normally in a blocking position and being able to be unblocked by moving the corresponding shaft segment (6) of the composite shaft by
30 actuating the handle of said lock (L).
2. A closure system for an entrance door according claim 1, wherein said bolt (50) comprises a cursor (53) which said oscillating bolt head (54) is hinged to, the cursor (53) being pushed in a resting position corresponding to the blocking position of the bolt head
35 (54) by a spring (57), the blockage being assured by the engagement of said cursor (53) with an oscillating lever (43) which is hinged to said envelope (52) of the bolt.

3. A closure system for an entrance door according claim 2, wherein said balancing lever (43) is substantially L-shaped, with a longer arm (45) extending longitudinally inside the envelope (52) which is hinged to, and a shorter arm (46) projecting from a side of the envelope (52), when the balancing lever (43) is engaged with the cursor (53), elastic means (48) being provided to normally keep the balancing lever (43) engaged with the cursor (53), said arm (46) of the lever (43) projecting from the envelope (52) being engaged by the corresponding segment of the composite shaft (6) during the actuation of the lock (L).
- 10 4. A closure system for an entrance door according claim 3, characterized in that said segment of composite shaft (6) comprises a plate (90) with shaped aperture (91) having a larger section (92), in which said projecting arm (46) of the balancing L-shaped lever (43) is housed freely, and a narrower section (93) which is defined by a cam profile (94) provided on a rim of the aperture (91), such as a translation of the plate (90) of the segment of the composite shaft (6) causes said cam profile (94) of the shaped hole (91) to slide against said projecting arm (46) of the L-shaped lever (43), determining the re-entry of said arm (46) inside the envelope (52) with the consequent balancing of the L-shaped lever (43), which disengages from the cursor (53) unblocking the bolt (50).
- 15 5. A closure system for an entrance door according to any one of the preceding claims, wherein said bolt head (54) is urged by a spring (56) in the blocking position and abuts against a jut (11) of said stop member (13) when the entrance door is closed, allowing anyway to pass over said jut (11) during the closing the entrance door, with the bolt (50) in the blocking position.
- 20 25 6. A closure system for an entrance door according to claim 4 or 5, characterized in that each segment (6) of composite shaft is split in two parts (60), (60'), fixed at both ends, to said perforated plate (90), each of said parts (60) (60') being, in turn, split in two further elements or latches (61), (62) e (61'), (62'), respectively, which can slide each on the others and being fixed in the desired positions to adjust the length of the segment (6) of the composite shaft on the basis of the height of the respective panel (P) of the entrance door or of the corresponding section of the sectional door (S).
- 30 35 7. A closure system for an entrance door according to claim 6, wherein said latches (61), (62) e (61') (62'), have opposed engaging tooth and are blocked by means of screws (81)

which pass through a longitudinal slit (64), (64') provided by the latches (62), (62') and are screwed in corresponding holes formed in the latches (61), (61').

- 5 8. A closure system for an entrance door according to claim 6 or 7, wherein said latches (61), (62) e (61'), (62'), and said perforated plate (90) are housed in a case formed by a plane base (70) and by a closing cap (80), holes (71) and (83) being provided respectively in said base (70) and in said cap (80) in alignment with the aperture (91) of the plate (90), for the passage of said bolt head (54).
- 10 9. A closure system for an entrance door according to claim 8, wherein the ends (65), (65') of the latches (62), (62'), projecting from said containment envelope are misaligned such as to be disposed on a side of the case, rather than in the centre of it, in order to be arranged on the inner side of the rim of the entrance door in mounted position, the position of the latches being optionally reversed during the mounting step, in order to
15 make the closure reversible.
10. A closure system for an entrance door according to any one of the preceding claims, characterized in that said lock (L) provides an operating member (1) displaceable along a horizontal direction, which is parallel to the plane of the entrance door, to actuate a
20 device (D) with toothed wheels transforming said horizontal displacement in a movement in vertical direction and in opposite senses of two segments (6) of composite shaft.

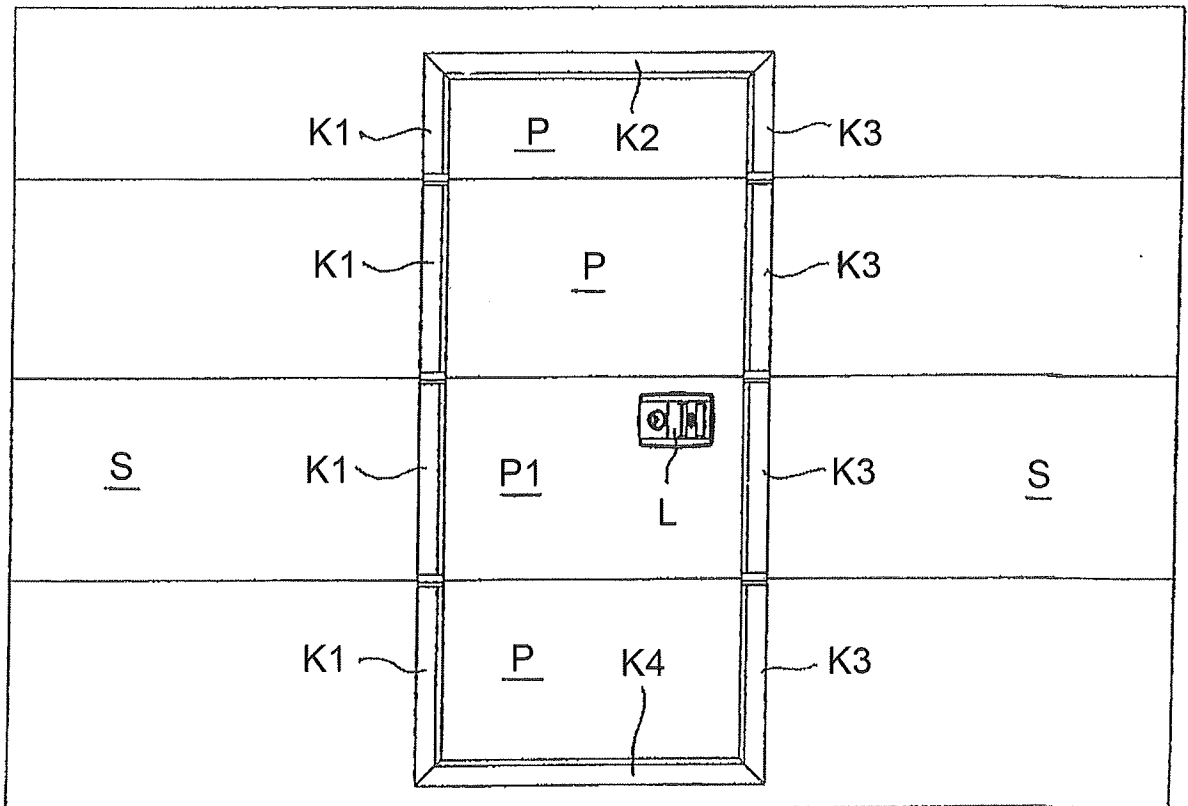

FIG. 1

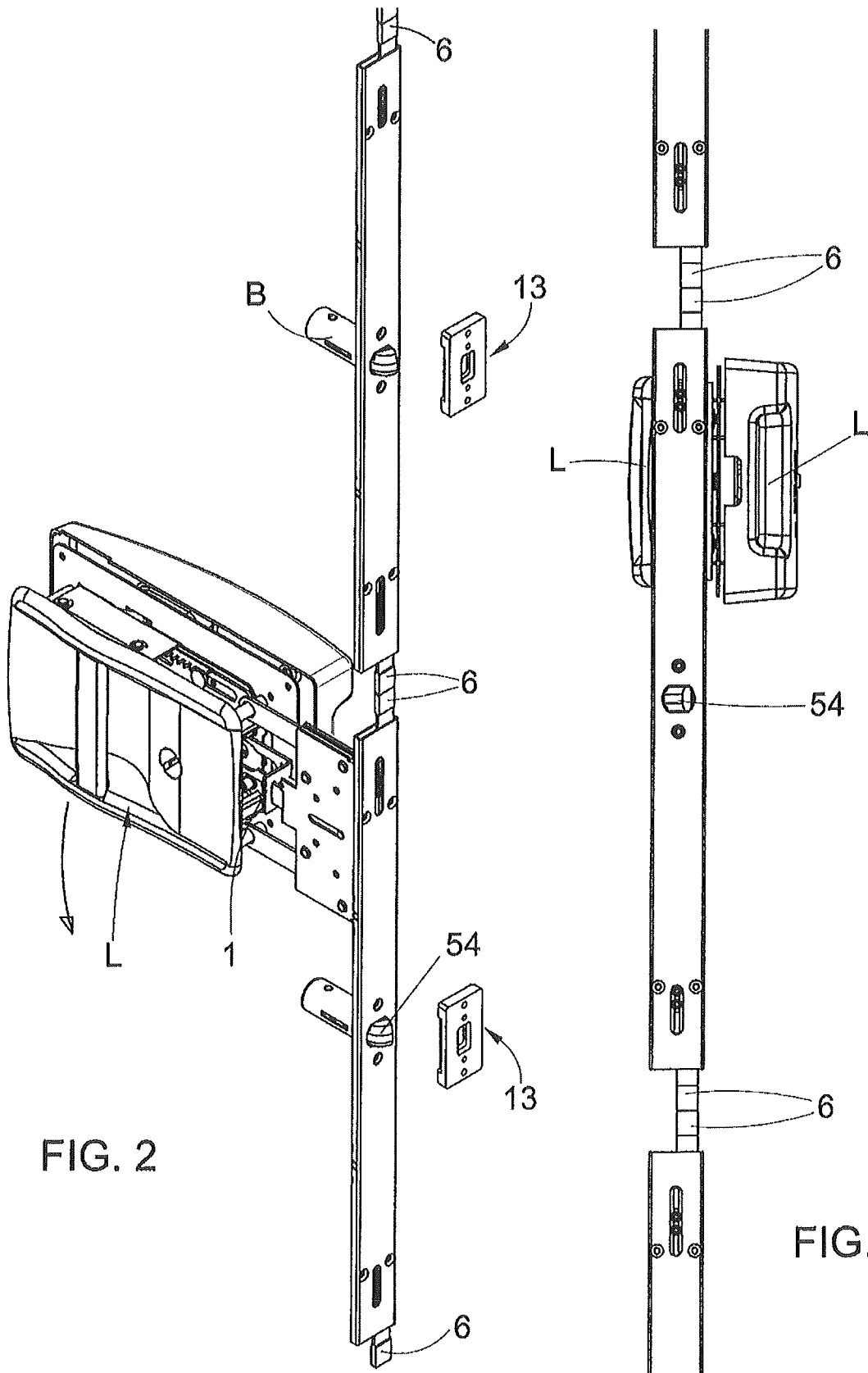

FIG. 2

FIG. 3

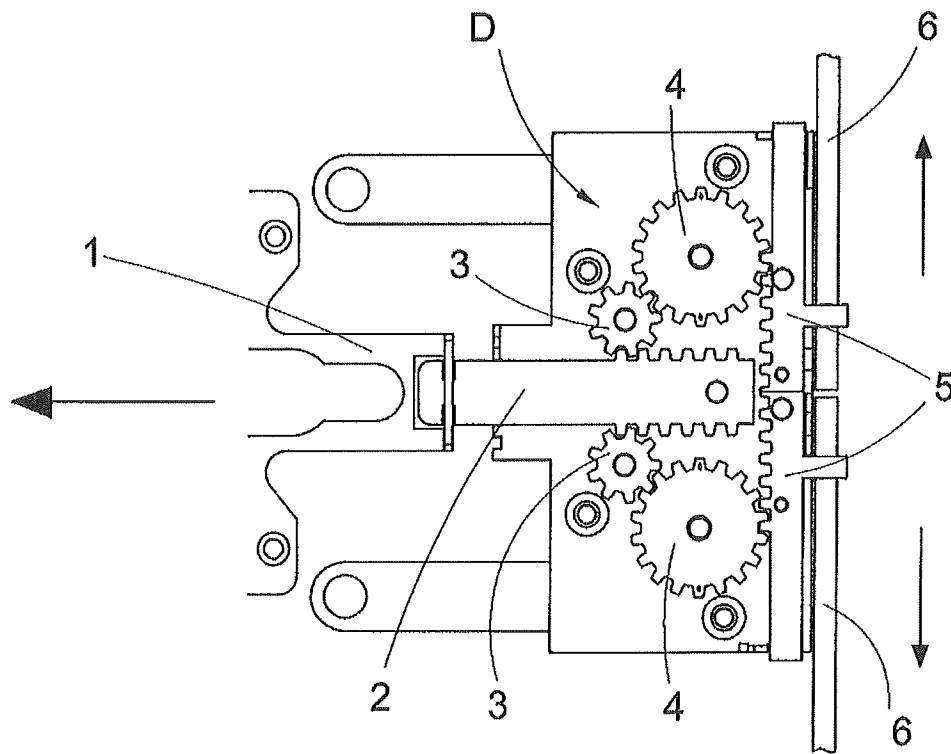

FIG. 4

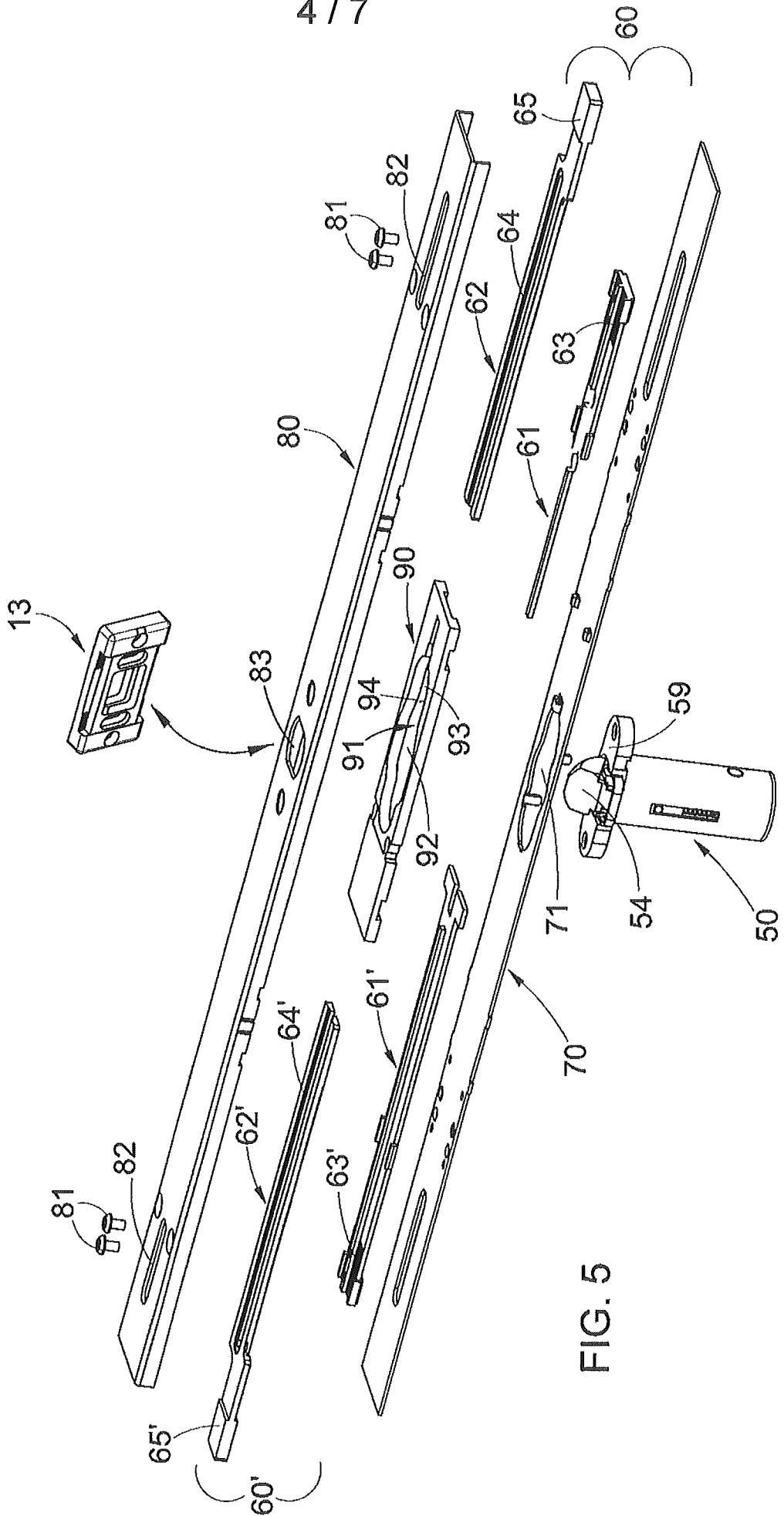
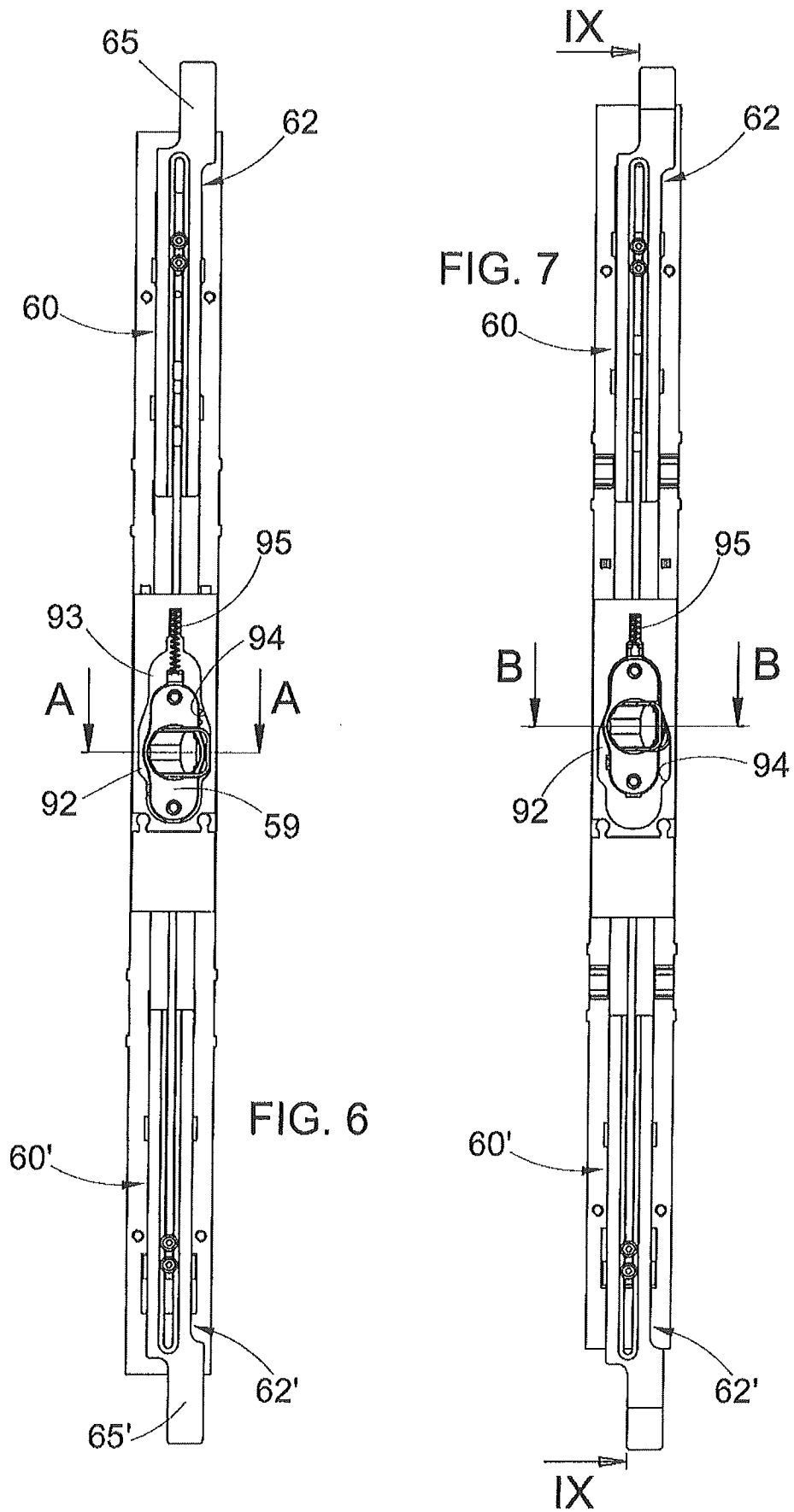

FIG. 5



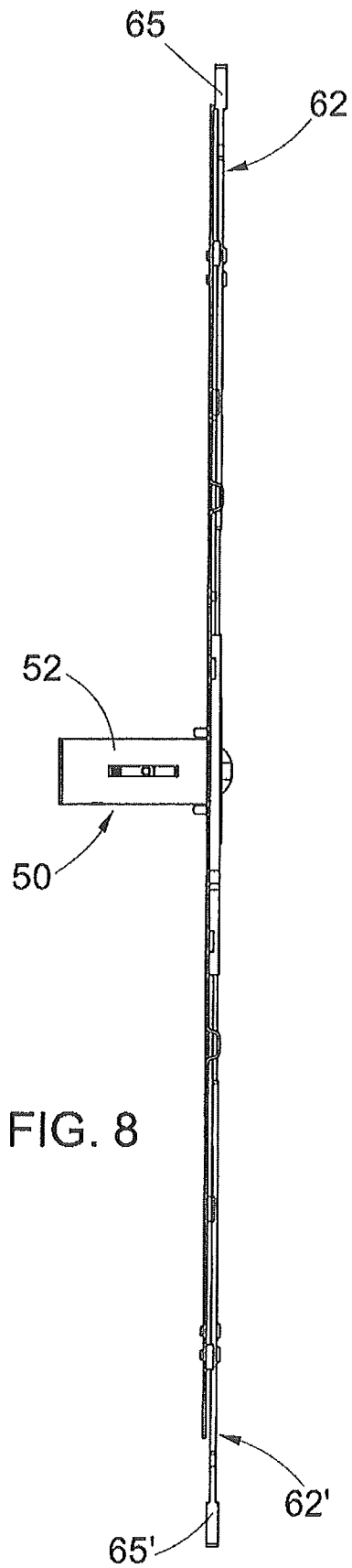

FIG. 8

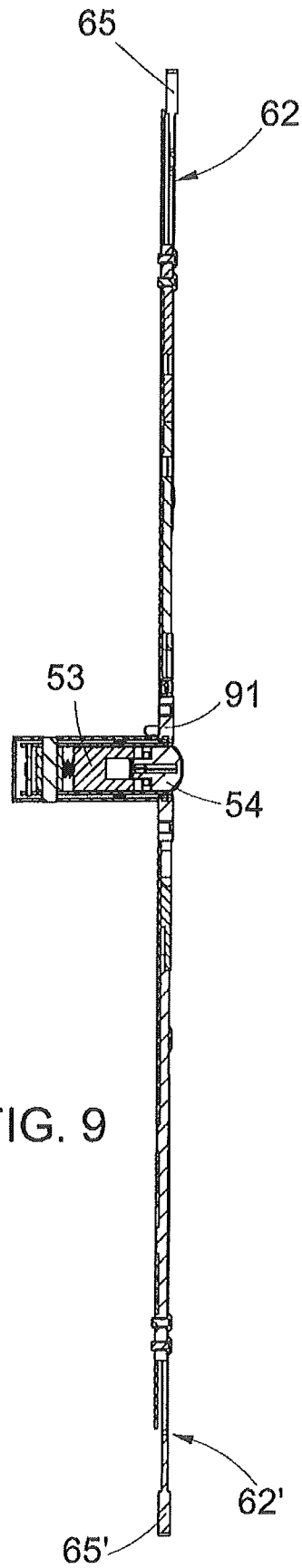
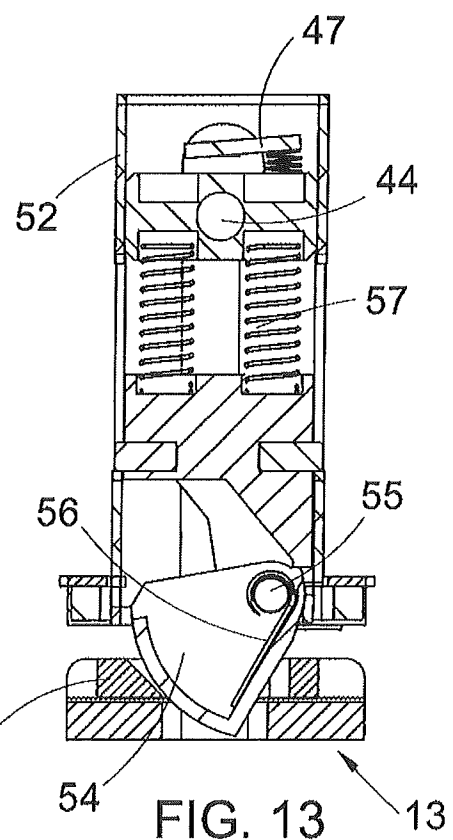
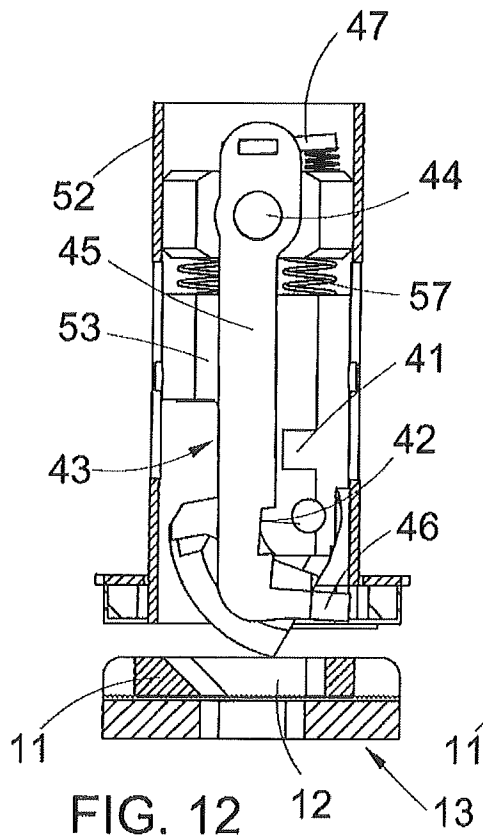
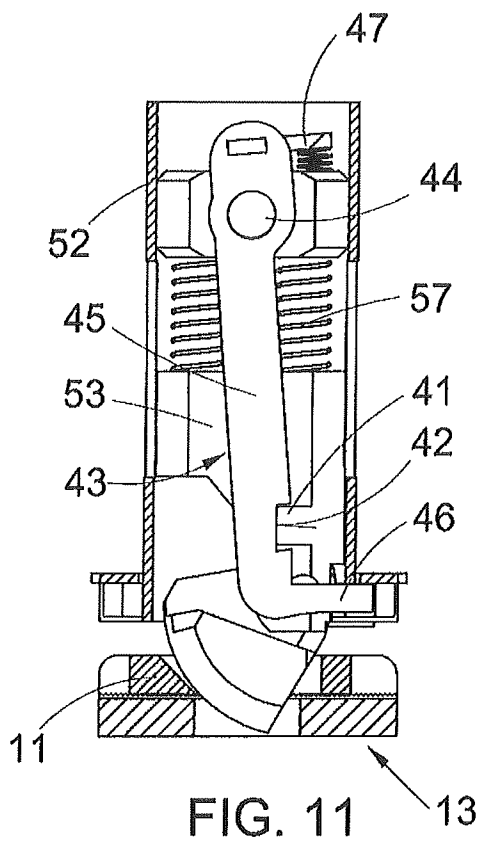
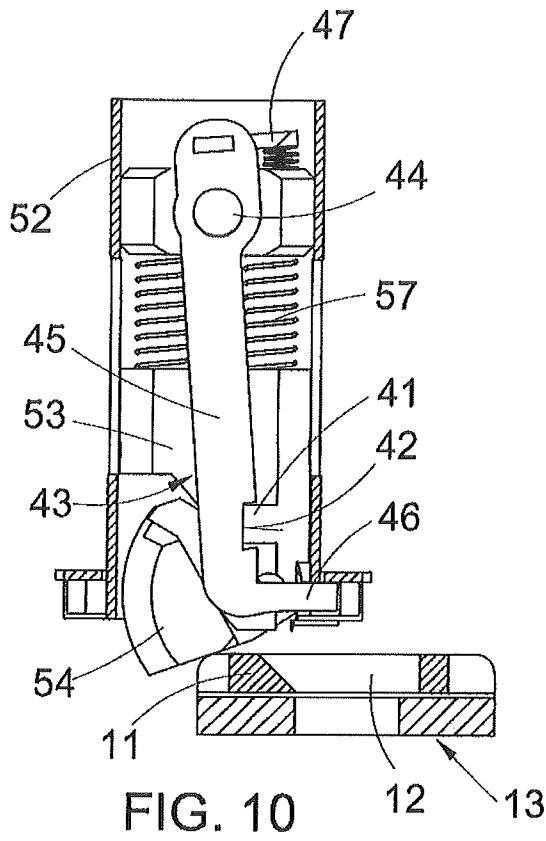

FIG. 9



INTERNATIONAL SEARCH REPORT

International application No
PCT/EP2012/062021

A. CLASSIFICATION OF SUBJECT MATTER		
INV.	E05B65/00	E05C9/04
		E05B15/10
		E06B3/48
ADD.	E05B55/12	E05B15/02
According to International Patent Classification (IPC) or to both national classification and IPC		
B. FIELDS SEARCHED		
Minimum documentation searched (classification system followed by classification symbols)		
E05B E05C E06B		
Documentation searched other than minimum documentation to the extent that such documents are included in the fields searched		
Electronic data base consulted during the international search (name of data base and, where practicable, search terms used)		
EPO-Internal		
C. DOCUMENTS CONSIDERED TO BE RELEVANT		
Category*	Citation of document, with indication, where appropriate, of the relevant passages	Relevant to claim No.
A	BE 528 030 A (VELGHE) 18 January 1957 (1957-01-18) page 3, line 47 - page 4, line 10 figures 1-3	1
A	FR 2 919 650 A1 (GELIN MICHEL GUY RENE [FR]) 6 February 2009 (2009-02-06) page 3, line 11 - line 22 figures 1-3	1
A	WO 2007/133364 A2 (BRUNETTE BARRY J [US]; BRUNETTE JEFFERY A [US]) 22 November 2007 (2007-11-22) the whole document	1
<input type="checkbox"/> Further documents are listed in the continuation of Box C. <input checked="" type="checkbox"/> See patent family annex.		
* Special categories of cited documents :		
"A" document defining the general state of the art which is not considered to be of particular relevance	"T" later document published after the international filing date or priority date and not in conflict with the application but cited to understand the principle or theory underlying the invention	
"E" earlier application or patent but published on or after the international filing date	"X" document of particular relevance; the claimed invention cannot be considered novel or cannot be considered to involve an inventive step when the document is taken alone	
"L" document which may throw doubts on priority claim(s) or which is cited to establish the publication date of another citation or other special reason (as specified)	"Y" document of particular relevance; the claimed invention cannot be considered to involve an inventive step when the document is combined with one or more other such documents, such combination being obvious to a person skilled in the art	
"O" document referring to an oral disclosure, use, exhibition or other means	"&" document member of the same patent family	
"P" document published prior to the international filing date but later than the priority date claimed		
Date of the actual completion of the international search	Date of mailing of the international search report	
3 October 2012	10/10/2012	
Name and mailing address of the ISA/ European Patent Office, P.B. 5818 Patentlaan 2 NL - 2280 HV Rijswijk Tel. (+31-70) 340-2040, Fax: (+31-70) 340-3016	Authorized officer Bitton, Alexandre	

INTERNATIONAL SEARCH REPORT

Information on patent family members

International application No PCT/EP2012/062021

Patent document cited in search report	Publication date	Patent family member(s)	Publication date
BE 528030	A	18-01-1957	NONE
FR 2919650	A1	06-02-2009	ES 2356171 T3 05-04-2011
			FR 2919650 A1 06-02-2009
			FR 2919651 A1 06-02-2009
WO 2007133364	A2	22-11-2007	CA 2651245 A1 22-11-2007
			US 2007272366 A1 29-11-2007
			US 2012199296 A1 09-08-2012
			WO 2007133364 A2 22-11-2007