

(12) INTERNATIONAL APPLICATION PUBLISHED UNDER THE PATENT COOPERATION TREATY (PCT)

(19) World Intellectual Property
Organization

International Bureau



WIPO | PCT



(10) International Publication Number

WO 2012/125769 A3

(43) International Publication Date
20 September 2012 (20.09.2012)

(51) International Patent Classification:

A61M 1/00 (2006.01) A61B 19/00 (2006.01)
A61M 27/00 (2006.01) A61C 17/06 (2006.01)

(21) International Application Number:

PCT/US2012/029131

(22) International Filing Date:

14 March 2012 (14.03.2012)

(25) Filing Language:

English

(26) Publication Language:

English

(30) Priority Data:

61/464,922 14 March 2011 (14.03.2011) US

(71) Applicant (for all designated States except US): NEURO ENTERPRISES, LLC [US/US]; 11 East Walton Street, #3401, Chicago, IL 60611 (US).

(72) Inventors; and

(75) Inventors/Applicants (for US only): SALEHI, Sean, A. [US/US]; 11 East Walton Street, Apt. #3401, Chicago, IL 60611 (US). WICKHAM, Jeff [US/US]; 130 Rossi Road, Geyserville, CA 95441 (US).

(74) Agents: SILVERT, Donald, J. et al.; Rosenbaum & Silvert, P.C., 1480 Techny Road, Northbrook, IL 60062 (US).

(81) Designated States (unless otherwise indicated, for every kind of national protection available): AE, AG, AL, AM,

AO, AT, AU, AZ, BA, BB, BG, BH, BR, BW, BY, BZ, CA, CH, CL, CN, CO, CR, CU, CZ, DE, DK, DM, DO, DZ, EC, EE, EG, ES, FI, GB, GD, GE, GH, GM, GT, HN, HR, HU, ID, IL, IN, IS, JP, KE, KG, KM, KN, KP, KR, KZ, LA, LC, LK, LR, LS, LT, LU, LY, MA, MD, ME, MG, MK, MN, MW, MX, MY, MZ, NA, NG, NI, NO, NZ, OM, PE, PG, PH, PL, PT, QA, RO, RS, RU, RW, SC, SD, SE, SG, SK, SL, SM, ST, SV, SY, TH, TJ, TM, TN, TR, TT, TZ, UA, UG, US, UZ, VC, VN, ZA, ZM, ZW.

(84) Designated States (unless otherwise indicated, for every kind of regional protection available): ARIPO (BW, GH, GM, KE, LR, LS, MW, MZ, NA, RW, SD, SL, SZ, TZ, UG, ZM, ZW), Eurasian (AM, AZ, BY, KG, KZ, MD, RU, TJ, TM), European (AL, AT, BE, BG, CH, CY, CZ, DE, DK, EE, ES, FI, FR, GB, GR, HR, HU, IE, IS, IT, LT, LU, LV, MC, MK, MT, NL, NO, PL, PT, RO, RS, SE, SI, SK, SM, TR), OAPI (BF, BJ, CF, CG, CI, CM, GA, GN, GQ, GW, ML, MR, NE, SN, TD, TG).

Published:

- with international search report (Art. 21(3))
- before the expiration of the time limit for amending the claims and to be republished in the event of receipt of amendments (Rule 48.2(h))

(88) Date of publication of the international search report:

27 December 2012

(54) Title: SELF-CLEANING SURGICAL SUCTION DEVICE

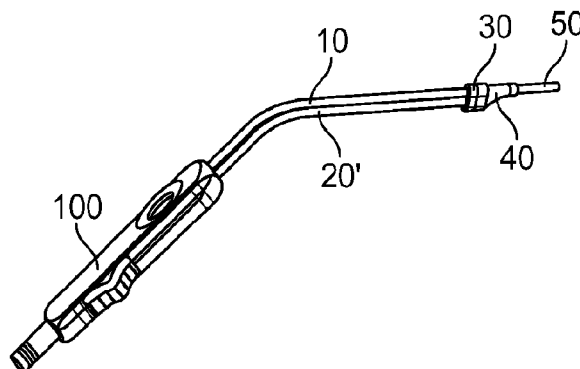

FIG. 1a

(57) Abstract: A surgical suction device is disclosed that includes a suction tube having a first longitudinal axis, a proximal opening, and a distal opening; a guide tube that is substantially coextensive with and parallel to the suction tube, and has a second longitudinal axis, a proximal opening, and a distal opening; a stylet having a proximal end and a distal end; and a junction conduit having a proximal opening and a distal opening; wherein the stylet is disposed along the second longitudinal axis and encircled by the guide tube, and the proximal opening of the junction conduit is in contact with the distal opening of the suction tube and the distal opening of the guide tube such that the distal opening of the junction conduit is in fluid communication with the suction tube, and urging the stylet through the guide tube along the second longitudinal axis through the junction conduit translates the distal end of the stylet to the distal opening of the junction conduit.



WO 2012/125769 A3

TITLE: SELF-CLEANING SURGICAL SUCTION DEVICE**FIELD OF THE INVENTION**

[001] The present invention relates to the field of surgical instruments employed for removing
5 debris from within a surgical operative field. In particular, the present invention is a tubular
suction device for surgical, dental, or veterinary use that includes a means for self-clearing debris
from its intake portion.

BACKGROUND

[002] A common requirement for any surgical procedure on a patient is that the operative field
10 opened in the patient must be continually cleared of fluids and particulates that obscure the
surgeon's vision of the field. These fluids and particulates can include blood, irrigating solution,
bone chips or dust, hemostatic agents, among others. Irrespective of the region of the body
where the surgery occurs, but especially with respect to neurological or orthopedic procedures,
significant amounts of these fluids and particulates present challenges to the surgeon's clear
15 viewing of the surgical field. In addition to the fluids and particulates derived from the patient,
foreign materials usefully employed as hemostatic agents can also obscure the operative field
and require removal. Such hemostatic agents include absorbable gelatin sponges (e.g., Gelfoam
from Baxter Healthcare Corporation), a kneadable mixture of beeswax and mineral wax (e.g.,
Ethicon Bone Wax from Johnson & Johnson), or an oxidized cellulose polymer (e.g., a polymer
20 of polyanhydroglucuronic acid sold under the trade name Surgicel by Johnson & Johnson).

[003] Removing these materials is typically accomplished using a surgical suction device,
inserting the distal tip of the surgical suction device in and about the operative field whereupon
the field-obscuring materials are sucked away to a location outside of the field; until, that is, the
distal tip becomes fouled by particulate matter or coagulated blood or combinations of such,
25 which is inevitable.

[004] The distal tip is commonly referred to as a surgical suction tip and is an integral part of
any surgical procedure. More particularly to the general view of the problem presented above,
the suction tip is connected to a wall suction unit in the surgical suite via a plastic tubing. The
suction (referred to below as negative pressure) created at the tip clears the field of the materials

mentioned above that may be obstructing the surgeon's field of view.

[005] The practical approach taken in a surgery to clear the clogged suction tips is to interrupt the surgery so the tip can be cleaned. Literally, the surgeon stops clearing the operative field, hands the clogged suction to the scrub nurse so s/he can clear it with saline flushes or a stylet (i.e., an implement employed to poke at and remove obstructing matter from a vacuum path). This process may have to be repeated multiple times in a surgery, prolonging the surgical time and contributing a significant source of inefficiency to the surgical procedure.

[006] Despite the development of various shapes of the suction tip inspired by the desire to eliminate the clogged distal tip problem, clogging of the suction tip remains a problem in all operating rooms. Accordingly, the surgeon uses the surgical suction device until its distal tip becomes clogged, hands it to an assistant who, under sterile conditions, manually replaces or unclogs the tip and hands the surgical suction device back to the surgeon. Obviously, critical time is lost by the need to hand the surgical suction device to an assistant for clearance, and then get it back, and then place it where it can do its intended task until, alas, the cycle is repeated with the distal tip yet again clogged, lost time, and a patient in surgery longer than necessary.

[007] It would be desirable to have a surgical suction device designed that allowed the surgeon to clear the distal tip directly without need to pass it off to another or otherwise lose time completing the work of addressing the patient's issues that caused the opening of the operative field in the first place.

20 SUMMARY

[008] To address these problems arising from frequently clogged surgical suction devices, the invention claimed herein enables the surgeon alone to remove obstructions at the distal tip of the surgical suction device. This invention thus bypasses the need for an assistant who, under sterile conditions, is handed a clogged surgical suction device, then manually replaces or unclogs the tip, and hands the surgical suction device back to the surgeon. The invention described herein also functions seamlessly with suction tips of various shapes, thus providing a surgeon with a choice of tip shapes suitable to the application.

[009] In a first embodiment, the invention described herein includes: (a) a suction tube having a first longitudinal axis, a proximal opening, and a distal opening; (b) a guide structure having a second longitudinal axis that is substantially parallel to the first longitudinal axis, a proximal

opening, and a distal opening; (c) a stylet having a proximal end and a distal end; and (d) a junction conduit having a proximal opening and a distal opening; wherein, the stylet is disposed along the second longitudinal axis and encircled by the guide structure, and the proximal opening of the junction conduit is in contact with at least the distal opening of the suction tube such that
5 the distal opening of the junction conduit is in fluid communication with the suction tube. Urging the stylet through the guide structure along the second longitudinal axis through the junction conduit translates the distal end of the stylet to the distal opening of the junction conduit.

[0010] In a second embodiment, the invention further includes a knob that is fixed at or about
10 the proximal end of the stylet; and/or a tubular base member having a proximal vacuum connector, an intermediate region, and a distal attachment region that are each in fluid communication with one another, wherein the distal attachment region is in contact with the proximal opening of the suction tube such that the proximal vacuum connector is in fluid communication with the suction tube. The tubular base member can include a vent feature
15 disposed on the intermediate region of the tubular base member that is in fluid communication with a vacuum source connected to the vacuum connector at the proximal end of the tubular base member. The vent can control the negative pressure exhibited at the site of the surgical field by the degree to which it is obstructed. To facilitate the degree of obstruction to the vent, the tubular base member includes a vent-surrounding member disposed on the intermediate region.
20 The vent also acts as a muffler to reduce sound created by the flow of air.

[0011] In a third embodiment, a receiving member disposed at the distal attachment region encircles the stylet and is coaxial with the guide structure along the second longitudinal axis.

[0012] A fourth embodiment includes a handle member that is operably attached to and surrounds the intermediate region and distal attachment region and includes a track element
25 extending substantially parallel to the second longitudinal axis that is proximate to the distal attachment region. A vent-access opening can also be included and disposed such that the vent and vent-surrounding member are accessible through the vent-access opening.

[0013] A fifth embodiment includes a tubular tip that contacts and is in fluid communication with the junction conduit.

[0014] For convenience of use, in some embodiments the suction tube is bent between the proximal end and distal end. When the suction tube is employed in a bent configuration, the guide structure may also be bent between the proximal end and distal end.

[0015] To stabilize the position of the guide structure, the receiving member is in contact with the proximal opening of the guide structure, and a bracket may be disposed proximate to the distal end of the suction tube and proximate to the distal end of the guide structure to conjoin the suction tube and guide structure.

[0016] The invention may have a guide structure that is a guide tube that is substantially parallel to and coextensive with the suction tube.

[0017] In some cases the guide structure is a shortened guide tube that is substantially parallel to the suction tube, and yet in other cases the guide structure is at least one annulus disposed on the suction tube.

[0018] In a sixth embodiment the suction device includes: (a) a suction tube having a first longitudinal axis, a proximal opening, a distal opening, and an entry port disposed proximate to the distal opening; (b) a guide structure having a second longitudinal axis that is substantially parallel to the first longitudinal axis, a proximal opening, and a distal opening; and (c) a hooked stylet having a proximal end and a hooked distal end; wherein, the stylet is disposed substantially along the second longitudinal axis and encircled by the guide structure such that the hooked distal end is disposed in or proximate to the entry port. As the hooked stylet is urged in the distal direction substantially along the second longitudinal axis and through the guide structure, the curvature of the hooked distal end meeting resistance from the distal edge of the entry port translates the hooked stylet into the suction tube and to the distal opening of the suction tube.

[0019] In a seventh embodiment, the invention further includes a knob that is fixed at or about the proximal end of the stylet; and/or a tubular base member having a proximal vacuum connector, an intermediate region, and a distal attachment region that are each in fluid communication with one another, wherein the distal attachment region is in contact with the proximal opening of the suction tube such that the proximal vacuum connector is in fluid communication with the suction tube. The tubular base member can include a vent feature disposed on the intermediate region of the tubular base member that is in fluid communication with a vacuum source connected to the vacuum connector at the proximal end of the tubular base

member. The vent can control the negative pressure exhibited at the site of the surgical field by the degree to which it is obstructed. To facilitate the degree of obstruction to the vent, the tubular base member includes a vent-surrounding member disposed on the intermediate region. The vent also acts as a muffler to reduce sound created by the flow of air.

5 [0020] In an eighth embodiment, a receiving member disposed at the distal attachment region encircles the stylet and is coaxial with the guide structure along the second longitudinal axis.

[0021] A ninth embodiment includes a handle member that is operably attached to and surrounds the intermediate region and distal attachment region and includes a track element extending substantially parallel to the second longitudinal axis that is proximate to the distal attachment
10 region. A vent-access opening can also be included and disposed such that the vent and vent-surrounding member are accessible through the vent-access opening.

[0022] For convenience of use, in some embodiments the suction tube is bent between the proximal end and distal end. When the suction tube is employed in a bent configuration, the guide structure may also be bent between the proximal end and distal end.

15 [0023] To stabilize the position of the guide structure, the receiving member is in contact with the proximal opening of the guide structure, and a bracket may be disposed proximate to the distal end of the suction tube and proximate to the distal end of the guide structure to conjoin the suction tube and guide structure.

[0024] The invention may have a guide structure that is a shortened guide tube that is
20 substantially parallel to the suction tube, and yet in other cases the guide structure is at least one annulus disposed on the suction tube.

[0025] A tenth embodiment of the suction device includes: (a) a suction tube having a first longitudinal axis, a proximal opening, a distal opening, and an entry port disposed proximate to the distal opening; (b) a guide structure having a second longitudinal axis, a proximal opening,
25 and a distal opening; and (c) a stylet having a proximal end and a distal end; wherein, the stylet is disposed substantially along the second longitudinal axis and encircled by the guide structure, and the distal opening of the guide structure is in contact with the entry port of the suction tube and in fluid communication with the distal opening. Urging the stylet through the guide structure substantially along the second longitudinal axis translates the distal end of the stylet through the
30 entry port of the suction tube to the distal opening of the suction tube.

[0026] In an eleventh embodiment, the invention further includes a knob that is fixed at or about the proximal end of the stylet; and/or a tubular base member having a proximal vacuum connector, an intermediate region, and a distal attachment region that are each in fluid communication with one another, wherein the distal attachment region is in contact with the proximal opening of the suction tube such that the proximal vacuum connector is in fluid communication with the suction tube. The tubular base member can include a vent feature disposed on the intermediate region of the tubular base member that is in fluid communication with a vacuum source connected to the vacuum connector at the proximal end of the tubular base member. The vent can control the negative pressure exhibited at the site of the surgical field by the degree to which it is obstructed. To facilitate the degree of obstruction to the vent, the tubular base member includes a vent-surrounding member disposed on the intermediate region. The vent also acts as a muffler to reduce sound created by the flow of air.

[0027] In a twelfth embodiment, a receiving member disposed at the distal attachment region encircles the stylet and is coaxial with the guide structure along the second longitudinal axis.

[0028] A thirteenth embodiment includes a handle member that is operably attached to and surrounds the intermediate region and distal attachment region and includes a track element extending substantially parallel to the second longitudinal axis that is proximate to the distal attachment region. A vent-access opening can also be included and disposed such that the vent and vent-surrounding member are accessible through the vent-access opening.

[0029] In a fourteenth embodiment, the guide structure is an alternative guide tube wherein the suction tube and alternative guide tube are bent between their respective proximal and distal ends such that the suction tube and guide structure are substantially parallel until the distal opening of the alternative guide tube connects with the entry port on the suction tube.

[0030] In a fifteenth embodiment, the suction device includes: (a) a suction tube having a first longitudinal axis, a proximal opening, a distal opening, and an entry port disposed proximate to the distal opening; (b) a guide structure having a second longitudinal axis that is substantially parallel to the first longitudinal axis, a proximal opening, and a distal opening; (c) a stylet having a proximal end and a distal end; and (d) a lip disposed about the distal end of the entry port; wherein, the stylet is disposed along the second longitudinal axis and encircled by the guide structure, and as the stylet is urged through the guide structure along the second longitudinal axis

the distal end of the stylet moves along the curvature or slope of the lip and is translated through the entry port to the distal opening of the suction tube.

[0031] In a sixteenth embodiment, the invention further includes a knob that is fixed at or about the proximal end of the stylet; and/or a tubular base member having a proximal vacuum connector, an intermediate region, and a distal attachment region that are each in fluid communication with one another, wherein the distal attachment region is in contact with the proximal opening of the suction tube such that the proximal vacuum connector is in fluid communication with the suction tube. The tubular base member can include a vent feature disposed on the intermediate region of the tubular base member that is in fluid communication with a vacuum source connected to the vacuum connector at the proximal end of the tubular base member. The vent can control the negative pressure exhibited at the site of the surgical field by the degree to which it is obstructed. To facilitate the degree of obstruction to the vent, the tubular base member includes a vent-surrounding member disposed on the intermediate region. The vent also acts as a muffler to reduce sound created by the flow of air.

[0032] In a seventeenth embodiment, a receiving member disposed at the distal attachment region encircles the stylet and is coaxial with the guide structure along the second longitudinal axis.

[0033] An eighteenth embodiment includes a handle member that is operably attached to and surrounds the intermediate region and distal attachment region and includes a track element extending substantially parallel to the second longitudinal axis that is proximate to the distal attachment region. A vent-access opening can also be included and disposed such that the vent and vent-surrounding member are accessible through the vent-access opening.

[0034] For convenience of use, in some embodiments the suction tube is bent between the proximal end and distal end. When the suction tube is employed in a bent configuration, the guide structure may also be bent between the proximal end and distal end.

[0035] To stabilize the position of the guide structure, the receiving member is in contact with the proximal opening of the guide structure, and a bracket may be disposed proximate to the distal end of the suction tube and proximate to the distal end of the guide structure to conjoin the suction tube and guide structure.

[0036] The invention may have a guide structure that is a shortened guide tube that is substantially parallel to the suction tube, and yet in other cases the guide structure is at least one annulus disposed on the suction tube.

[0037] The foregoing and other features and advantages of the invention are apparent from the following detailed description of embodiments read in conjunction with the accompanying drawings. The detailed description and drawings are merely illustrative of the invention rather than limiting. The scope of the invention is defined by the appended claims and equivalents thereof. It is intended that all changes or modification within the meaning and range of equivalents are embraced by the claims.

10 **BRIEF DESCRIPTION OF THE DRAWINGS**

[0038] FIG. 1a is a perspective view of one embodiment of the self-cleaning surgical suction device.

[0039] FIG. 1b is a perspective blown up view of the embodiment of the self-cleaning surgical suction device depicted in FIG. 1a.

15 [0040] FIG. 2a is a profile view of a guide structure employed in one embodiment of the present invention.

[0041] FIG. 2b is a frontal view from the distal end of the suction tube depicted in FIG. 2a.

[0042] FIG. 3a is a profile view of a guide tube employed in one embodiment of the present invention.

20 [0043] FIG. 3b is a frontal view from the distal end of the guide tube depicted in FIG. 3a.

[0044] FIG. 4 is a perspective view of one embodiment wherein the distal end of the suction tube extends beyond the distal opening of the bracket.

[0045] FIG. 5a is a perspective view of the junction element.

[0046] FIG. 5b is a frontal view of the proximal opening of the junction conduit.

25 [0047] FIG. 5c is a cross sectional view of the junction conduit along section A-A.

[0048] FIG. 6 is a profile view and frontal view of the tubular tip.

[0049] FIG. 7a is a top view of the tubular base member.

[0050] FIG. 7b is a profile view of the tubular base member.

[0051] FIG. 7c is frontal view of the distal end of the tubular base member.

[0052] FIG. 8a is a perspective view of the stylet with the attached knob.

5 [0053] FIG. 8b is a frontal view of the knob.

[0054] FIG. 9 is a perspective view of the dorsal handle piece.

[0055] FIG. 10 is a perspective view of the ventral handle piece.

[0056] FIG. 11 is a perspective view of the tubular base, stylet, suction tube, and guide tube assembled and disposed in the ventral handle piece.

10 [0057] FIG. 12 is a perspective view illustrating the nearness of the distal dorsal recess and distal ventral recess to the outer wall of the distal attachment region once attachment of the handle piece is completed.

[0058] FIG. 13 is a perspective cross sectional view along section A-A of a tubular member, stylet, and knob assembled and disposed within a completed handle piece.

15 [0059] FIG. 14 is a perspective view of an alternative embodiment that utilizes at least one annulus to guide a stylet to a junction conduit.

[0060] FIG. 15 is a perspective view of an alternative embodiment wherein a shortened guide tube guides a stylet into a junction conduit.

20 [0061] FIG. 16 is a perspective view of an alternative embodiment wherein at least one annulus is used to maintain a hooked end of a stylet in an entry port near a distal opening of a suction tube.

[0062] FIG. 17 is a perspective view of an alternative embodiment wherein a shortened guide tube is used to maintain a hooked end of a stylet in an entry port near a distal opening of a suction tube.

25 [0063] FIG. 18 is a perspective view of an alternative embodiment of the invention wherein an alternative guide tube can feed a stylet directly into a suction tube near a distal opening of a

suction tube.

[0064] FIG. 19 is a perspective view of an alternative embodiment of the invention wherein a shortened guide tube guides a stylet to a lip.

[0065] FIG. 20 is a perspective view of an alternative embodiment of the invention wherein at least one annulus guides a stylet to a lip.

DETAILED DESCRIPTION

[0066] As shown in FIGs. 1a and 1b, one embodiment of a self-cleaning surgical suction device **1** comprises a suction tube **10**, a guide structure **20**, a bracket **30**, a junction conduit **40**, a tubular tip **50**, a base member **60**, a stylet **70**, and a handle member **100**; wherein, the guide structure **20** is in the form of a guide tube **20'**.

[0067] In one embodiment of the self-cleaning surgical suction device **1**, the suction tube **10** and guide tube **20'** are substantially parallel to and coextensive with each other. As shown in FIG. 2a, the suction tube **10** includes a first longitudinal axis **12**, a proximal opening **14**, and a distal opening **16**. In the depicted embodiment, the suction tube **10** measures about five inches to about six inches in length with an inner diameter of about five-hundredths of an inch to about a tenth of an inch and an outer diameter of about a tenth of an inch to about fifteen hundredths of an inch. Other embodiments of the present invention include a suction tube **10** that is substantially shorter or longer, having inner diameters and outer diameters that are substantially smaller or larger as befits the intended use. For example, a veterinarian about to surgically remove debris from a laceration in a large animal, appropriately sedated, would be better served using a larger surgical suction device **1**; whereas, a dentist needing to sculpt a tooth in a young child would find a smaller such device more serviceable. Accordingly, the dimensions presented for the suction tube, as well as other components of the present invention, are merely examples of the various described embodiments of the present invention and are by no means to be considered limiting.

[0068] FIG. 3a illustrates the guide tube **20'** which includes a second longitudinal axis **22**, a proximal opening **24** and a distal opening **26**. The guide tube **20'** measures about five inches to about six inches in length with an inner diameter of about five-hundredths of an inch to about a tenth of an inch and an outer diameter of about a tenth of an inch to about fifteen-hundredths of an inch.

[0069] The suction tube **10** and guide tube **20'** may be made from materials such as any of the following, without limitation intended: (a) metals, such as stainless steel, aluminum, and other suitable metals or alloys thereof; (b) polymers, such as polyvinylchloride, nylon, polytetrafluoroethylene, polystyrene, acrylonitrile-butadiene styrene, polypropylene, and other suitable plastics; or (c) ceramics, such as silicon carbide, tungsten carbide, apatite, and other suitable ceramics; wherein the suitable metals, alloys, plastics, or ceramics respectively have a tensile strength sufficient to maintain a tubular structure and are capable of being sterilized for medical use. One of ordinary skill in the art is necessarily familiar with the indicated range of alternative materials that have the identified characteristics associated with their suitability for the identified use.

[0070] As shown in FIG. 1, the suction tube **10** and the guide tube **20'** may be bent obliquely. Alternatively, the suction tube **10** and the guide tube **20'** may be bent to approximate a right angle. In yet other embodiments, the suction tube **10** and the guide tube **20'** are not bent.

[0071] The suction tube **10** and guide tube **20'** may be conjoined by the bracket **30** proximate to the distal opening **16** of the suction tube **10** and the distal opening **26** of the guide tube **20'**, as illustrated by the completed assembly in FIG. 1a. The bracket **30** may be disposed at the distal end of the suction tube **10** and guide tube **20'** by overmolding, frictional attachment, welding, and/or glued around the suction tube **10** and guide tube **20'**. In one embodiment, the bracket is overmolded and glued around the suction tube **10** and guide tube **20'**. As shown in FIG. 4, a small length of the suction tube **10** extends beyond the distal end of the bracket **30**. In other embodiments a small length of both the suction tube **10** and guide tube **20'** may extend beyond the distal end of the bracket **30** or a small length of the guide tube **20'** may extend beyond the distal end of the bracket **30**.

[0072] The distal opening **16** of suction tube **10** extending beyond the distal end of the bracket **30** is in contact with a junction conduit **40** by way of inserting the distal end of the suction tube **10** extending beyond the distal end of the bracket **30** into a proximal opening **42** of the junction conduit **40** and set by a suitable adhesive, e.g., a cyanoacrylate adhesive, such as Loctite® 4011™ or 4161™ Prism® manufactured by Henkel, such that a distal opening **44** of the junction conduit **40** is substantially coaxial with the suction tube **10** along first longitudinal axis **12**, and in fluid communication with the suction tube **10**.

[0073] In alternative embodiments, the distal opening **44** of the junction conduit **40** is not coaxial

with the suction tube **10** along the first longitudinal axis **12**. The proximal opening **42**, as shown in FIG. 5b, has an elliptical shape with an inner minor axis length **43** ranging from about a tenth of an inch to about fifteen-hundredths of an inch. The junction conduit **40** may alternatively be set by welding. The junction conduit **40** may also be set by frictional attachment enabling
5 disengagement of the junction conduit **40** from the suction tube **10**.

[0074] The bracket **30** and junction conduit **40** may be made from materials such as any of the following, without limitation intended: (a) metals, such as stainless steel, aluminum, and other suitable metals or alloys thereof; (b) polymers, such as polyvinylchloride, nylon, polytetrafluoroethylene, polystyrene, acrylonitrile-butadiene styrene, polypropylene, and other
10 suitable plastics; or (c) ceramics, such as silicon carbide, tungsten carbide, apatite, and other suitable ceramics; wherein the suitable metals, alloys, plastics, or ceramics respectively have a tensile strength sufficient to maintain the intended structure and are capable of being sterilized for medical use. One of ordinary skill in the art is necessarily familiar with the indicated range of alternative materials that have the identified characteristics associated with their suitability for
15 the identified use.

[0075] As shown in FIG. 1, a tubular tip **50** may be in contact with the junction conduit **40**. FIG. 6 illustrates that the tubular tip **50** has a proximal opening **52** and distal opening **54**. The tubular tip **50** may be made of metals, alloys, polymers, or ceramics as mentioned above for alternative materials for the suction tube **10** and the guide tube **20**. The proximal opening **52** and
20 distal opening **54** have outer diameters ranging from about a tenth of an inch to about fifteen-hundredths of an inch, inner diameters ranging from about five-hundredths of an inch to about a tenth of an inch, and may or may not be uniform. In one embodiment, the tubular tip **50** is in contact with the junction conduit **40** by way of inserting the proximal end of the tubular tip **50** through the distal opening **44** of the junction conduit **40** and set by a suitable adhesive,
25 e.g., a cyanoacrylate adhesive, such as Loctite® 4011™ or 4161™ Prism® manufactured by Henkel, such that the tubular tip **50** is coaxial with the suction tube **10** along the first longitudinal axis **12**, and in fluid communication with the suction tube **10**. In alternative embodiments the tubular tip **50** is not coaxial with the suction tube **10** along the first longitudinal axis **12**.

[0076] The tubular tip **50** may alternatively be set by welding. The tubular tip **50** may also be
30 fitted without welding or adhesives enabling disengagement of the tubular tip **50** from the junction conduit **40**. For example, the tubular tip **50** may have an outside diameter that may

allow the tip to be pushed into the distal opening **44** of the junction conduit **40** and held by frictional forces. In another example, the proximal end of the tubular tip **50** may be threaded so that it may be twisted into the junction conduit **40** which, in this example, has corresponding threads disposed proximate to the inner diameter of the distal opening **44** of the junction conduit **40**.

[0077] As shown in FIG. 1, an embodiment of a self-cleaning surgical suction device **1** also comprises a tubular base member **60**. FIG. 7a shows that the tubular base member **60** comprises a proximal vacuum connector **62**, an intermediate region **64**, a distal attachment region **66**, and a distal attachment opening **67** that is in fluid communication with the proximal vacuum connector **62**. The tubular base **60** may be made from materials such as any of the following, without limitation intended: (a) metals, such as stainless steel, aluminum, and other suitable metals or alloys thereof; (b) polymers, such as polyvinylchloride, nylon, polytetrafluoroethylene, polystyrene, acrylonitrile-butadiene styrene, polypropylene, and other suitable plastics; or (c) ceramics, such as silicon carbide, tungsten carbide, apatite, and other suitable ceramics; wherein the suitable metals, alloys, plastics, or ceramics respectively have a tensile strength sufficient to maintain the intended structure and are capable of being sterilized for medical use. One of ordinary skill in the art is necessarily familiar with the indicated range of alternative materials that have the identified characteristics associated with their suitability for the identified use. In one embodiment, the tubular base **60** is made of acrylonitrile-butadiene styrene.

[0078] The proximal end of the suction tube **10** is inserted into the distal attachment region **66** through the distal attachment opening **67** such that the suction tube **10** is in fluid communication with the proximal vacuum connector **62**. The suction tube **10** is set within the distal attachment region **66** by welding or adhesives such that the tubular base member **60** is coaxial with the suction tube **10** along the first longitudinal axis **12**. In one embodiment, the suction tube **10** is set within the distal attachment region **66** by a suitable adhesive, e.g., a cyanoacrylate adhesive, such as Loctite 4011 or 4161 Prism® manufactured by Henkel. Alternative embodiments not shown include a connection such that the distal attachment region **66** is set within the suction tube **10** by welding or adhesives such that the suction tube **10** is coaxial with the tubular base member **60**.

[0079] As shown in FIG. 7b, the tubular base member **60** also comprises a receiving member **65**, a proximal receiving member opening **68**, and a distal receiving member opening **69**. The receiving member **65** may be disposed on the distal attachment region **66** by welding, gluing, or

may be part of a monolithic mold or cast of the tubular base member **60**. In one embodiment, the receiving member **65** is tubular and disposed on the distal attachment region **66** as part of a monolithic molding of the tubular base member **60** such that the receiving member **65** is substantially parallel to the distal attachment region **66**.

5 [0080] The proximal opening **24** of the guide tube **20** is in contact with the receiving member **65** by way of inserting the proximal end of the guide tube **20** into the receiving member **65** through the distal receiving member opening **69**. The guide tube **20** may be set within the receiving member **65** by welding or adhesives such that the receiving member **65** is coaxial with the guide tube **20** along the second longitudinal axis **22**. In one embodiment, the guide tube **20** is set
10 within the receiving member **65** by a suitable adhesive, e.g., a cyanoacrylate adhesive, such as Loctite 4011 or 4161 Prism® manufactured by Henkel. Alternative embodiments not shown include a connection such that the receiving member **65** is set within the guide tube **20** by welding or adhesives such that the receiving member **65** is coaxial with the guide tube **20** along the second longitudinal axis **22**.

15 [0081] The proximal vacuum connector **62** may or may not have external threads **62a** facilitating firm attachment of vacuum tubing (not shown) to the vacuum connector **62**.

[0082] A vent **61**, as shown in FIG. 7a, is disposed on the intermediate region **64** of the tubular base member **60** and is in fluid communication with the proximal vacuum connector **62** and the distal opening **54** of the tubular tip **50**. The vent **61** can act as a muffler by decreasing the noise
20 from rapid air flow. The vent **61** can also control the amount of negative pressure at the distal opening **54** of the tubular tip **50** by varying the amount the vent **61** is obstructed.

[0083] A vent-surrounding member **63** surrounds the vent **61** and facilitates manual control of the degree of obstruction. The vent-surrounding member **63** may be made from materials such as any of the following, without limitation intended: (a) metals, such as stainless steel,
25 aluminum, and other suitable metals or alloys thereof; (b) polymers, such as polyvinylchloride, nylon, polytetrafluoroethylene, polystyrene, acrylonitrile-butadiene styrene, polypropylene, and other suitable plastics; or (c) ceramics, such as silicon carbide, tungsten carbide, apatite, and other suitable ceramics; wherein the suitable metals, alloys, plastics, or ceramics respectively have a tensile strength sufficient to maintain the intended structure and are capable of being
30 sterilized for medical use. One of ordinary skill in the art is necessarily familiar with the indicated range of alternative materials that have the identified characteristics associated with

their suitability for the identified use. In one embodiment, the vent-surrounding member **63** is made of acrylonitrile-butadiene styrene.

[0084] The vent surrounding member **63** may be welded to the tubular base member **60**, glued to the tubular base member **60**, or may be part of a monolithic mold or cast of the tubular base member **60**. In one embodiment the vent surrounding member **63** is glued on the intermediate region **64** of the tubular base member **60** by a suitable adhesive, e.g., a cyanoacrylate adhesive, such as Loctite 4011 or 4161™ Prism manufactured by Henkel. In one embodiment the vent surrounding member **63** is concave and has an elliptical geometry to further aid in controlling the degree vent **61** is obstructed. Other embodiments may include a rectangular, and/or flat vent surrounding member **63**. Another embodiment does not include the vent surrounding member **63**.

[0085] A stylet **70** having a proximal end **72** and distal end **74**, as shown in FIG. 8a, is disposed within the guide tube **20'** by inserting the distal end **74** of the stylet **70** into the proximal receiving member opening **68**, through the receiving member **65**, out the distal receiving member opening **69**, and into the guide tube **20'**. The length of stylet **70** ranges from about seven inches to about nine inches. The diameter of the stylet **70** ranges from about five-hundredths of an inch to about a tenth of an inch. The stylet **70** may be made from materials such as any of the following without limitation intended: (a) metals such as stainless steel, aluminum, and other suitable metals or alloys thereof, or (b) polymers such as nylon, polyvinylchloride, polytetrafluoroethylene, polystyrene, acrylonitrile-butadiene styrene, polypropylene, and other suitable plastics; wherein the suitable metals, alloys, or plastics respectively have the suitable elasticity for non-linear movement and can be sterilized for medical use. One of ordinary skill in the art is necessarily familiar with the indicated range of alternative materials that have the identified characteristics associated with their suitability for the identified use. In one embodiment, the stylet is composed of a polymer compound, more particularly, the stylet is composed of nylon, polyvinylchloride, polytetrafluoroethylene, polystyrene, acrylonitrile-butadiene styrene, polypropylene, and other suitable plastics, the suitability of which is a function of sufficient flexibility, stiffness, and ability to be sterilized at least once.

[0086] As shown in FIG. 8b, a knob **75** having a node **76**, a web **77**, a flange **78**, and a grip **79** may be fixed to the stylet **70** by welding, gluing, and/or frictionally attaching the grip **79** to about the proximal end of the stylet **70**. In one embodiment the knob **75** is fixed at about the proximal

end 72 of the stylet 70 by frictional attachment to the grip 79, and in another embodiment the knob 75 may be located at about the proximal end of the stylet 70 as part of a monolithic mold or cast of the stylet 70. In one embodiment, the knob 75 facilitates manual urging of the stylet 70 in the distal direction through the guide tube 20' along the second longitudinal axis 22 by manually displacing the node 76 in the distal direction. As the distal end 74 of the stylet 70 is urged through the junction conduit 40, the motion of the distal end 74 is translated from the second longitudinal axis 22 to the first longitudinal axis 12 out the distal opening 44 of the junction conduit 40 and through the tubular tip 50. The distal end 74 of the stylet 70 can be retracted by manually displacing the knob 75 by urging the node 76 towards the proximal direction. Negative pressure exhibited at the distal opening 54 of the tubular tip 50 may be varied in proportion to the manual displacement of the knob 75 as the distal end 74 of the stylet 70 coincides with the suction tube 10.

[0087] The flange 78 may take an "L" shape with a curved bend as shown from a frontal view for an embodiment of the invention shown in FIG. 8b. The flange 78 may take other shapes such as an "L" shape with a sharp angled bend or any other suitable shape that allows the flange 78 and grip 79 assembly to get around the tubular base member 60.

[0088] The knob 75 may be made from materials such as any of the following, without limitation intended: (a) metals, such as stainless steel, aluminum, and other suitable metals or alloys thereof; (b) polymers, such as polyvinylchloride, nylon, polytetrafluoroethylene, polystyrene, acrylonitrile-butadiene styrene, polypropylene, and other suitable plastics; or (c) ceramics, such as silicon carbide, tungsten carbide, apatite, and other suitable ceramics; wherein the suitable metals, alloys, plastics, or ceramics respectively have a tensile strength sufficient to maintain the intended structure and are capable of being sterilized for medical use. One of ordinary skill in the art is necessarily familiar with the indicated range of alternative materials that have the identified characteristics associated with their suitability for the identified use. In one embodiment, the knob 75 is made of acrylonitrile-butadiene styrene.

[0089] As shown in FIG. 1, an embodiment also includes a handle member 100 comprising of a dorsal handle piece 80 and a ventral handle piece 90. The dorsal handle piece 80, as shown in FIG. 9, includes a vent-access opening 82, a plurality of interference fit posts 84, a proximal dorsal recess 86, and a distal dorsal recess 88. The dorsal handle piece 80 may be made from materials such as any of the following without limitation intended: (a) metals such as stainless

steel, aluminum, and other suitable metals or alloys thereof; (b) polymers such as nylon, polyvinylchloride, polytetrafluoroethylene, polystyrene, acrylonitrile-butadiene styrene, polypropylene, and other suitable plastics; or (c) ceramics such as silicon carbide, tungsten carbide, apatite, and other suitable ceramics; wherein the material has the tensile strength to
5 maintain the manufactured structure and can be sterilized for medical use. One of ordinary skill in the art is necessarily familiar with the indicated range of alternative materials that have the identified characteristics associated with their suitability for the identified use. In an embodiment, the dorsal handle piece **80** is made of acrylonitrile-butadiene styrene and includes four interference fit posts **84**.

10 [0090] The ventral handle piece **90**, as shown in FIG. 10, includes a plurality of sockets **92** that receive the interference frit posts **84** of the dorsal handle piece **80**, a track element **94**, a proximal ventral recess **96**, and a distal ventral recess **98**. The ventral handle piece **90** may be made from materials such as any of the following without limitation being intended: (a) metals such as stainless steel, aluminum, and other suitable metals or alloys thereof; (b) polymers such as nylon,
15 polyvinylchloride, polytetrafluoroethylene, polystyrene, acrylonitrile-butadiene styrene, polypropylene, or other suitable plastics; or (c) ceramics such as silicon carbide, tungsten carbide, apatite, or other suitable ceramics; wherein the material has the tensile strength to maintain the manufactured structure and can be sterilized for medical use. One of ordinary skill in the art is necessarily familiar with the indicated range of alternative materials that have the
20 identified characteristics associated with their suitability for the identified use. In one embodiment, the dorsal handle piece **90** is made of acrylonitrile-butadiene styrene and includes four sockets **92**.

[0091] As shown in FIG. 11, the inner cavity of the ventral handle piece **90** is suitable for disposing the tubular base member **60** and the region proximate to the proximal end **72** of the
25 stylet **70** within its inner cavity. The web **77** of the knob **75** has a proper length known to one of ordinary skill in the art to traverse the width of the track element **94** as shown in FIG. 11, thus allowing accessibility to the node **76** of the knob **75** for urging the connected stylet **70** along the second longitudinal axis **22**. The plurality of interference frit posts **84** are inserted to the corresponding sockets **92** of the dorsal handle piece **80** to complete the handle member **100**
30 surrounding the intermediate region **64** and the distal attachment region **66** of the base member **60**. After inserting the interference frit posts **84** into the corresponding sockets **92**, the

dorsal handle piece **80** and ventral handle piece **90** may be welded, glued, and/or frictionally attached to each other. In one embodiment, the dorsal handle piece **80** is glued to the ventral handle piece **90** by a suitable adhesive, e.g., a cyanoacrylate adhesive, such as Loctite 4011 or 4161 Prism manufactured by Henkel. In other embodiments the handle member **100** may be
5 overmolded on the tubular base member **60**.

[0092] As shown in FIG. 12, the proximal dorsal recess **86** and corresponding proximal ventral recess **96** encircle the tubular base member **60** proximate to the proximal vacuum connector **62** such that the nearness of the proximal dorsal recess **86** and the proximal ventral recess **96** to the outer wall of the tubular base member **60** allows for gluing, welding, and/or frictional
10 attachment.

[0093] The distal dorsal recess **88** and distal ventral recess **98** encircle the tubular base member **60** proximate to the distal attachment region **66** such that the nearness of the distal dorsal recess **88** and the distal ventral recess **98** to the outer wall of the tubular base member **60** allows for gluing, welding, and/or frictional attachment.

[0094] In one embodiment the dorsal hand piece **80** and the ventral hand piece **90** are glued to the outer wall of the tubular base member **60** at the proximal dorsal recess **86**, the proximal ventral recess **96**, the distal dorsal recess **88**, and distal ventral recess **98** by a suitable adhesive, e.g., a cyanoacrylate adhesive, such as Loctite 4011 or 4161 Prism manufactured by Henkel.
15

[0095] The vent-access opening **82** has dimensions known to one having ordinary skill in the art to surround the vent surrounding member **61** allowing for welding, gluing, and/or frictional attachment. In one embodiment, the vent-access opening **82** is glued to the vent surrounding member **62** by a suitable adhesive, e.g., a cyanoacrylate adhesive, such as Loctite® 4011 or 4161 Prism manufactured by Henkel.
20

[0096] In one embodiment shown in FIG. 1, the proximal vacuum connector **62** of the tubular base member **60** remains exposed.
25

[0097] In one embodiment shown in FIG. 10, the depth of the track element **94** on the ventral handle piece **90** should be suitable so that by disposing the dorsal handle piece **80** on the ventral handle piece **90** limits the knob **75** to displacement that is substantially parallel to the second longitudinal axis **22** along the track element **94**. In one embodiment shown in FIG. 11 and FIG.
30 13, the proper length of the web **77** as known to one having ordinary skill in the art restricts the

flange **78** to the interior cavity of the handle member **100** which impedes lateral movement of the knob **75** and further limits the knob **75** to displacement that is substantially parallel to the second longitudinal axis **22** along the track element **94**.

[0098] As shown in FIG. 14, one alternative embodiment of the self-cleaning surgical suction device **1** comprises a guide structure **20** of at least one annulus **20''** disposed on the suction tube **10** such that the annulus **20''** guides the stylet **70** through the proximal opening **42** of the junction conduit **40** and is substantially coaxial with the second longitudinal axis **22**. Furthermore, the annulus **20''** should be disposed on the suction tube **10** to provide suitable guidance as the distal end **74** of the stylet **70** is urged in the distal direction substantially along the second longitudinal axis **22**. The annulus **20''** may be disposed on the suction tube by welding, gluing, or as part of a monolithic mold or cast of the suction tube **10**. The annulus **20''** may be made from materials such as any of the following without limitation intended: (a) metals such as stainless steel, aluminum, and other suitable metals or alloys thereof; (b) polymers such as nylon, polyvinylchloride, polytetrafluoroethylene, polystyrene, acrylonitrile-butadiene styrene, polypropylene, and other suitable plastics; or (c) ceramics such as silicon carbide, tungsten carbide, apatite, and other suitable ceramics; wherein the suitable metals, alloys, plastics, or ceramics respectively have a tensile strength sufficient to maintain an annular structure and are capable of being sterilized for medical use. One of ordinary skill in the art is necessarily familiar with the indicated range of alternative materials that have the identified characteristics associated with their suitability for the identified use.

[0099] As shown in FIG. 15, one alternative embodiment of the self-cleaning surgical suction device **1** comprises a guide structure **20** in the form of a shortened guide tube **20'''** having a second longitudinal axis **22**, a proximal opening **24**, and distal opening **26**. The shortened guide tube **20'''** may be made from materials such as any of the following, without limitation intended: (a) metals, such as stainless steel, aluminum, and other suitable metals or alloys thereof; (b) polymers, such as nylon, polyvinylchloride, polytetrafluoroethylene, polystyrene, acrylonitrile-butadiene styrene, polypropylene, and other suitable plastics; or (c) ceramics, such as silicon carbide, tungsten carbide, apatite, and other suitable ceramics; wherein the suitable metals, alloys, plastics, or ceramics respectively have a tensile strength sufficient to maintain a tubular structure and are capable of being sterilized for medical use. One of ordinary skill in the art is necessarily familiar with the indicated range of alternative materials that have the identified

characteristics associated with their suitability for the identified use.

[00100] The shortened guide tube **20'''** may be substantially parallel to the suction tube **10**. The suction tube **10** and shortened guide tube **20'''** may be conjoined by the bracket **30** proximate to the distal opening **16** of the suction tube **10** and the distal opening **26** of the shortened guide tube **20'''**, as illustrated by the completed assembly in FIG. 15. The bracket **30** may be disposed at the distal end of the suction tube **10** and shortened guide tube **20'''** by overmolding, frictional attachment, welding, and/or glued around the suction tube **10** and shortened guide tube **20'''**.

[00101] In the depicted embodiment of FIG. 15, the proximal opening **24** is in contact with the receiving member **65** by way of inserting the proximal end of the shortened guide tube **20'''** into the receiving member **65** through the distal receiving member opening **69**. The shortened guide tube **20'''** may be set within the receiving member **65** by welding or adhesives such that the receiving member **65** is coaxial with the shortened guide tube **20'''** along the second longitudinal axis **22**. In one alternative embodiment, the shortened guide tube **20'''** is set within the receiving member **65** by a suitable adhesive, e.g., a cyanoacrylate adhesive, such as Loctite 4011 or 4161 Prism manufactured by Henkel. Alternative embodiments not shown include a connection such that the receiving member **65** is set within the shortened guide tube **20'''** by welding or adhesives such that the receiving member **65** is coaxial with the shortened guide tube **20'''** along the second longitudinal axis **22**.

[00102] Another alternative embodiment of the self-cleaning surgical suction device **1**, as shown in FIG. 16, does not incorporate the junction conduit **40**. Instead, a hooked stylet **112** is guided by a guide structure **20** of at least one annulus **20''** so that a hooked distal end **113** of the hooked stylet **112** is disposed within the entry port **114** disposed proximate to the distal end of the suction tube **10**. The annulus **20''** may be disposed on the suction tube by welding, gluing, or as part of a monolithic mold or cast of the suction tube **10**. As the hooked stylet **112** is urged in the distal direction substantially along the second longitudinal axis **22** through the annulus **20''**, the curvature of the hooked distal end **113** meeting resistance from the distal edge of the entry port **114** translates the hooked stylet **112** into the suction tube **10** and to the distal opening **16** of the suction tube **10**.

[00103] The hooked stylet **112** may be made from materials such as any of the following without limitation intended: (a) metals such as stainless steel, aluminum, and other suitable metals or alloys thereof, or (b) polymers such as polyvinylchloride, polytetrafluoroethylene, polystyrene, acrylonitrile-butadiene styrene, polypropylene, and other suitable plastics; wherein
5 the suitable metals, alloys, or plastics respectively have the suitable elasticity for non-linear movement, suitable shape memory to retain a hooked disposition at the distal end of the hooked stylet **112**, and can be sterilized for medical use. One of ordinary skill in the art is necessarily familiar with the indicated range of alternative materials that have the identified characteristics associated with their suitability for the identified use. The annulus **20''** can be made from
10 materials as described herein.

[00104] Another alternative embodiment of the self-cleaning surgical suction device **1**, as shown in FIG. 17, does not incorporate the junction conduit **40**. Instead, a hooked stylet **112** is guided by a guide structure **20** in the form of a shortened guide tube **20'''** so that a hooked distal end **113** of the hooked stylet **112** is disposed within the entry port **114** disposed proximate to the
15 distal end of the suction tube **10**. The suction tube **10** and shortened guide tube **20'''** may be conjoined by the bracket **30** proximate to the distal opening **16** of the suction tube **10** and the distal opening **26** of the shortened guide tube **20'''**, as illustrated by the completed assembly in FIG. 15. The bracket **30** may be disposed at the distal end of the suction tube **10** and shortened
20 guide tube **20'''** by overmolding, frictional attachment, welding, and/or glued around the suction tube **10** and shortened guide tube **20'''**. As the hooked stylet **112** is urged in the distal direction substantially along the second longitudinal axis **22**, the curvature of the hooked distal end **113** meeting resistance from the distal edge of the entry port **114** translates the hooked stylet **112** into the suction tube **10** and to the distal opening **16** of the suction tube **10**. The hooked stylet **112** may be made from materials as described herein. The shortened guide tube **20'''** can be made
25 from materials as described herein.

[00105] An alternative embodiment of the self-cleaning surgical suction device **1**, as shown in FIG. 18, does not incorporate the junction conduit **40** or the tubular tip **50**. Instead, the alternative embodiment of FIG. 14 comprises a guide structure **20** in the form of an alternative
30 guide tube **116** having a longitudinal axis (not shown) which intersects the first longitudinal axis **12**, a proximal opening (not shown), and a distal opening (not shown) that is in contact with an entry port **114**, as shown in FIG. 16, which is disposed proximate to the distal end of the

suction tube **10**. The alternative guide tube **116** may be substantially parallel to the suction tube **10** until the distal opening contacts the entry port **114**. Urging the stylet **70** along the longitudinal axis of the alternative guide tube **116** translates the distal end **74** of the stylet **70** through the entry port **114** of the suction tube **10** and to the distal opening **16** of the suction tube **10**.

[00106] The alternative guide tube **116** may be made from materials such as any of the following without limitation intended: (a) metals such as stainless steel, aluminum, and other suitable metals or alloys thereof; (b) polymers such as polyvinylchloride, polytetrafluoroethylene, polystyrene, acrylonitrile-butadiene styrene, polypropylene, and other suitable plastics; or (c) ceramics such as silicon carbide, tungsten carbide, apatite, and other suitable ceramics; wherein the suitable metals, alloys, plastics, or ceramics respectively have a tensile strength sufficient to maintain a tubular structure and are capable of being sterilized for medical use. One of ordinary skill in the art is necessarily familiar with the indicated range of alternative materials that have the identified characteristics associated with their suitability for the identified use.

[00107] As shown in FIG. 19, another alternative embodiment of the self-cleaning surgical suction device **1** does not incorporate the junction conduit **40** or the tubular tip **50**. Instead, the alternative embodiment depicted in FIG. 19 comprises a lip **118** which functions to translate the distal movement of the stylet **70** into the entry port **114** and to the distal opening **16** of the suction tube **10**. As the stylet **70** is urged through the guide structure **20** in the form of a shortened guide tube **20''**, a lip **118** disposed about the distal end of the entry port **114** guides the distal end **74** along an interior slope or curvature of the lip **118** into the entry port **114** and to the distal opening **16** of the suction tube **10**. The lip **118** may be disposed about the distal end of the entry port **114** as a part of the monolithic suction tube **10** structure, it may be glued about the distal end of the entry port **114**, or it may be welded about the distal end of the entry port **114**.

[00108] The lip **118** may be made from materials such as any of the following without limitation intended: (a) metals such as stainless steel, aluminum, and other suitable metals or alloys thereof; (b) polymers such as polyvinylchloride, polytetrafluoroethylene, polystyrene, acrylonitrile-butadiene styrene, polypropylene, and other suitable plastics; or (c) ceramics such as silicon carbide, tungsten carbide, apatite, and other suitable ceramics; wherein the suitable metals, alloys, plastics, or ceramics respectively have a tensile strength sufficient to provide

suitable resistance to the translation movement of the stylet **70** such that the distal end **74** of the stylet **70** may move along the interior slope or curvature of the lip **118** structure and are capable of being sterilized for medical use. One of ordinary skill in the art is necessarily familiar with the indicated range of alternative materials that have the identified characteristics associated with their suitability for the identified use.

[00109] The suction tube **10** and shortened guide tube **20'''** may be conjoined by the bracket **30** proximate to the distal opening **16** of the suction tube **10** and the distal opening **26** of the shortened guide tube **20'''**, as illustrated by the completed assembly in FIG. 19. The bracket **30** may be disposed at the distal end of the suction tube **10** and shortened guide tube **20'''** by overmolding, frictional attachment, welding, and/or glued around the suction tube **10** and shortened guide tube **20'''**.

[00110] Yet another alternative embodiment of the self-cleaning surgical suction device **1**, as shown in FIG. 20, also does not incorporate the junction conduit **40** or the tubular tip **50**. Similar to a prior embodiment shown in FIG. 19, the alternative embodiment depicted in FIG. 20 comprises a lip **118** which functions to translate the distal movement of the stylet **70** into the entry port **114** and to the distal opening **16** of the suction tube **10**. However, the guide structure **20** is at least one annulus **20''**. The annulus **20''** may be disposed on the suction tube by welding, gluing, or as part of a monolithic mold or cast of the suction tube **10**.

[00111] As the stylet **70** is urged through at least one annulus **20''**, a lip **118** disposed about the distal end of the entry port **114** guides the distal end **74** along an interior slope or curvature of the lip **118** into the entry port **114** and to the distal opening **16** of the suction tube **10**. The lip **118** may be disposed about the distal end of the entry port **114** as a part of the monolithic suction tube **10** structure, it may be glued about the distal end of the entry port **114**, or it may be welded about the distal end of the entry port **114**. The lip **118** may be made from materials as described herein.

[00112] A common feature shared by the various embodiments described herein above is a method comprising the steps of: (a) urging a stylet **70** through a guide structure **20** along a second longitudinal axis **22**; (b) translation of the stylet movement from the second longitudinal **22** axis into the suction tube **10** along a first longitudinal axis **12**; and (c) retracting the stylet **70** such that the stylet **70** is disposed substantially within the guide structure **20** substantially along the second longitudinal axis **22**. This method can be repeated any number of

times, as required to clear obstructions from the surgical suction device of the present invention.

[00113] While the present invention has been described in its various embodiments with some degree of particularity, it is understood that this description has been provided only by way of example and that numerous changes in the details of construction, fabrication, and use, including changes in the combination and arrangement of parts or materials, may be made
5 without departing from the spirit and scope of the invention.

WHAT IS CLAIMED:

1. A suction device comprising:

(a) a suction tube having a first longitudinal axis, a proximal opening, and a distal opening;

5 (b) a guide structure having a second longitudinal axis that is substantially parallel to the first longitudinal axis, a proximal opening, and a distal opening;

(c) a stylet having a proximal end and a distal end; and

(d) a junction conduit having a proximal opening and a distal opening;

wherein:

10 • the stylet is disposed along the second longitudinal axis and encircled by the guide structure, and

• the proximal opening of the junction conduit is in contact with at least the distal opening of the suction tube such that

15 ○ the distal opening of the junction conduit is in fluid communication with the suction tube, and

○ urging the stylet through the guide structure along the second longitudinal axis through the junction conduit translates the distal end of the stylet to the distal opening of the junction conduit.

2. The device of claim 1, further comprising a tubular base member having a proximal vacuum connector, an intermediate region, a distal attachment region, and a vent disposed on the
20 intermediate region in fluid communication with the vacuum connector that are each in fluid communication with one another, wherein the distal attachment region is in contact with the proximal opening of the suction tube such that the proximal vacuum connector is in fluid communication with the suction tube, and wherein the tubular base member further comprises a
25 vent-surrounding member disposed on the intermediate region.

3. The device of claim 2, further comprising a receiving member disposed at the distal attachment region, wherein the receiving member encircles the stylet and is coaxial with the guide structure along the second longitudinal axis.

4. The device of claim 3, further comprising a handle member that is operably attached to and
30 surrounds the intermediate region and distal attachment region which includes a track element extending substantially parallel to the second longitudinal axis that is proximate to the distal

attachment region, and a vent-access opening such that the vent and vent-surrounding member are accessible through the vent-access opening.

5. The device of claim 4, further comprising a tubular tip that contacts and is in fluid communication with the junction conduit and a knob fixed at or about the proximal end of the stylet; wherein the suction tube is bent between the proximal end and distal end, the receiving member is in contact with the proximal opening of the guide structure, and the guide structure is
5 (i) a guide tube that is substantially parallel to and coextensive with the suction tube wherein a bracket is disposed proximate to the distal end of the suction tube and proximate to the distal end of the guide tube, which bracket conjoins the suction tube and guide tube, or (ii) a shortened
10 guide tube that is substantially parallel to the suction tube wherein a bracket is disposed proximate to the distal end of the suction tube and proximate to the distal end of the guide tube, which bracket conjoins the suction tube and guide tube, or (iii) at least one annulus disposed on the suction tube.

6. A suction device comprising:

- 15 (a) a suction tube having a first longitudinal axis, a proximal opening, a distal opening, and an entry port disposed proximate to the distal opening;
- (b) a guide structure having a second longitudinal axis that is substantially parallel to the first longitudinal axis, a proximal opening, and a distal opening; and
- (c) a hooked stylet having a proximal end and a hooked distal end;

20 wherein:

- the stylet is disposed substantially along the second longitudinal axis and encircled by the guide structure such that the hooked distal end is disposed in or proximate to the entry port, and
- as the hooked stylet is urged in the distal direction substantially along the second
25 longitudinal axis and through the guide structure, the curvature of the hooked distal end meeting resistance from the distal edge of the entry port translates the hooked stylet into the suction tube and to the distal opening of the suction tube.

7. The device of claim 6, further comprising a tubular base member having a proximal vacuum connector, an intermediate region, a distal attachment region, and a vent disposed on the
30 intermediate region in fluid communication with the vacuum connector that are each in fluid communication with one another, wherein the distal attachment region is in contact with the

proximal opening of the suction tube such that the proximal vacuum connector is in fluid communication with the suction tube, and wherein the tubular base member further comprises a vent-surrounding member disposed on the intermediate region.

8. The device of claim 7, further comprising a receiving member disposed at the distal attachment region, wherein the receiving member encircles the stylet and is coaxial with the guide structure along the second longitudinal axis.

9. The device of claim 8, further comprising a handle member that is operably attached to and surrounds the intermediate region and distal attachment region which includes a track element extending substantially parallel to the second longitudinal axis that is proximate to the distal attachment region, and a vent-access opening such that the vent and vent-surrounding member are accessible through the vent-access opening.

10. The device of claim 9, further comprising a knob fixed at or about the proximal end of the stylet; wherein the suction tube is bent between the proximal end and distal end, the receiving member is in contact with the proximal opening of the guide structure, and the guide structure is (i) a shortened guide tube that is substantially parallel to the suction tube wherein a bracket is disposed proximate to the distal end of the suction tube and proximate to the distal end of the guide tube, which bracket conjoins the suction tube and guide tube, or (iii) at least one annulus disposed on the suction tube.

11. A suction device comprising:

- (a) a suction tube having a first longitudinal axis, a proximal opening, a distal opening, and an entry port disposed proximate to the distal opening;
- (b) a guide structure having a second longitudinal axis, a proximal opening, and a distal opening; and
- (c) a stylet having a proximal end and a distal end;

wherein:

- the stylet is disposed substantially along the second longitudinal axis and encircled by the guide tube, and
- the distal opening of the guide structure is in contact with the entry port of the suction tube and in fluid communication with the distal opening such that

o urging the stylet through the guide structure substantially along the second longitudinal axis translates the distal end of the stylet through the entry port of the suction tube to the distal opening of the suction tube.

12. The device of claim 11, further comprising a tubular base member having a proximal vacuum connector, an intermediate region, a distal attachment region, and a vent disposed on the intermediate region in fluid communication with the vacuum connector that are each in fluid communication with one another, wherein the distal attachment region is in contact with the proximal opening of the suction tube such that the proximal vacuum connector is in fluid communication with the suction tube, and wherein the tubular base member further comprises a vent-surrounding member disposed on the intermediate region.

13. The device of claim 12, further comprising a receiving member disposed at the distal attachment region, wherein the receiving member encircles the stylet and is coaxial with the guide structure along the second longitudinal axis.

14. The device of claim 13, further comprising a handle member that is operably attached to and surrounds the intermediate region and distal attachment region which includes a track element extending substantially parallel to the second longitudinal axis that is proximate to the distal attachment region, and a vent-access opening such that the vent and vent-surrounding member are accessible through the vent-access opening.

15. The device of claim 14, further comprising a knob fixed at or about the proximal end of the stylet; wherein the suction tube is bent between the proximal end and distal end, the receiving member is in contact with the proximal opening of the guide structure, and the guide structure is an alternative guide tube wherein the alternative guide tube is substantially parallel with the suction tube until the distal opening of the alternative guide tube connects with the entry port on the suction tube.

25

16. A suction device comprising:

(a) a suction tube having a first longitudinal axis, a proximal opening, a distal opening, and an entry port disposed proximate to the distal opening;

(b) a guide structure having a second longitudinal axis that is substantially parallel to the first longitudinal axis, a proximal opening, and a distal opening;

(c) a stylet having a proximal end and a distal end; and

(d) a lip disposed about the distal end of the entry port;

wherein:

- the stylet is disposed along the second longitudinal axis and encircled by the guide structure, and
- as the stylet is urged through the guide structure along the second longitudinal axis the distal end of the stylet moves along an interior slope or curvature of the lip and is translated through the entry port to the distal opening of the suction tube.

17. The device of claim 16, further comprising a tubular base member having a proximal vacuum connector, an intermediate region, a distal attachment region, and a vent disposed on the intermediate region in fluid communication with the vacuum connector that are each in fluid communication with one another, wherein the distal attachment region is in contact with the proximal opening of the suction tube such that the proximal vacuum connector is in fluid communication with the suction tube, and wherein the tubular base member further comprises a vent-surrounding member disposed on the intermediate region.

18. The device of claim 17, further comprising a receiving member disposed at the distal attachment region, wherein the receiving member encircles the stylet and is coaxial with the guide structure along the second longitudinal axis.

19. The device of claim 18, further comprising a handle member that is operably attached to and surrounds the intermediate region and distal attachment region which includes a track element extending substantially parallel to the second longitudinal axis that is proximate to the distal attachment region, and a vent-access opening such that the vent and vent-surrounding member are accessible through the vent-access opening.

20. The device of claim 19, further comprising a knob fixed at or about the proximal end of the stylet; wherein the suction tube is bent between the proximal end and distal end, the receiving

member is in contact with the proximal opening of the guide structure, and the guide structure is (i) a shortened guide tube that is substantially parallel to the suction tube wherein a bracket is disposed proximate to the distal end of the suction tube and proximate to the distal end of the guide tube, which bracket conjoins the suction tube and guide tube, or (iii) at least one annulus

5 disposed on the suction tube.

1/11

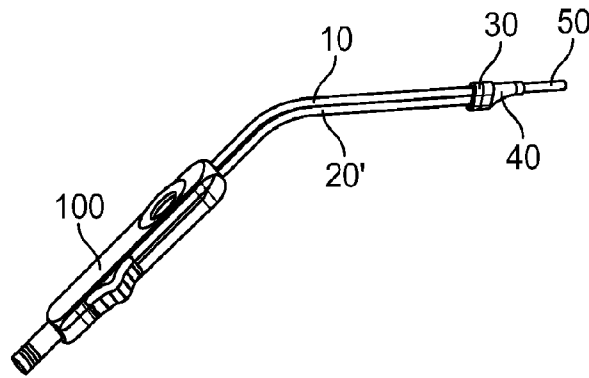

FIG. 1a

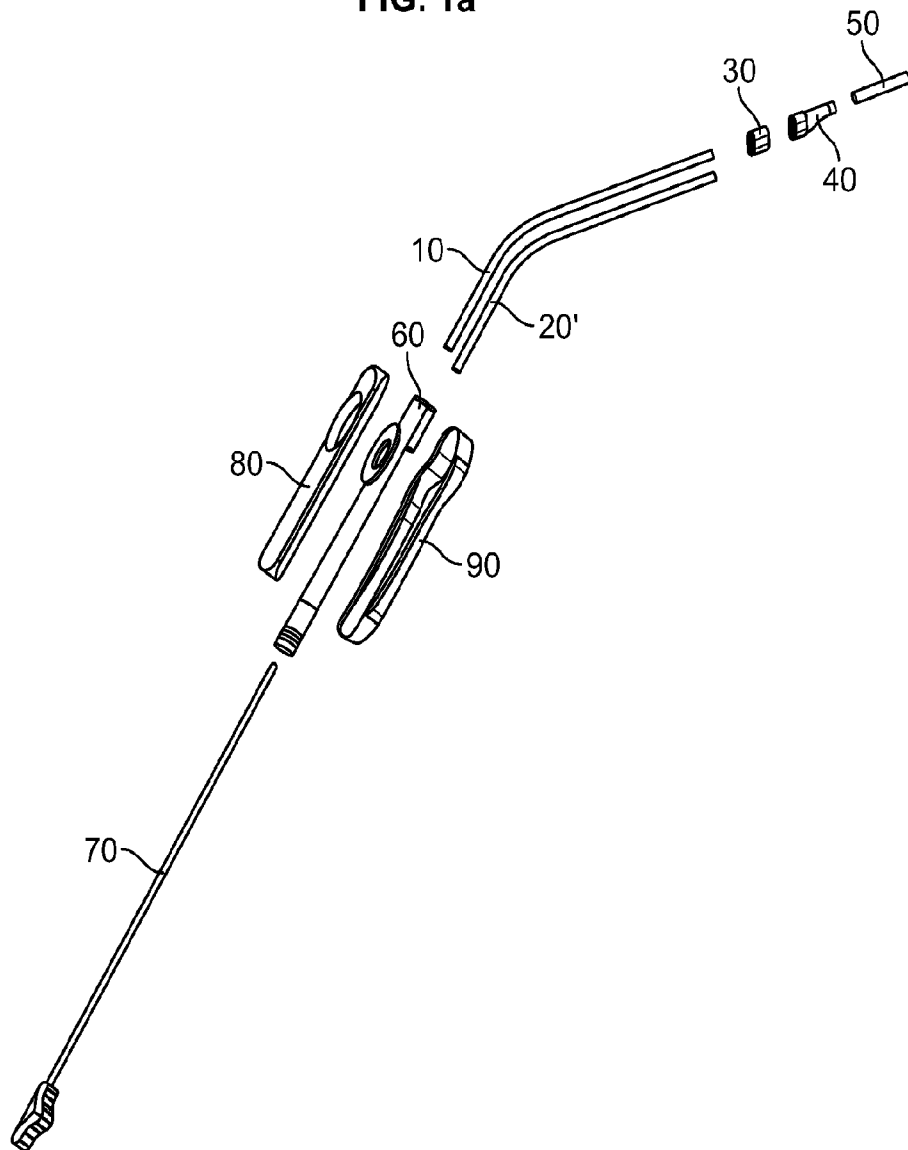

FIG. 1b

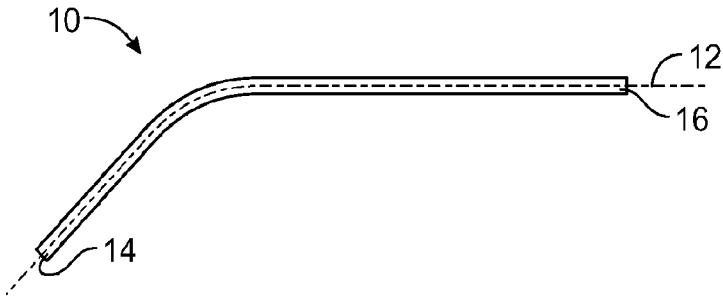

FIG. 2a

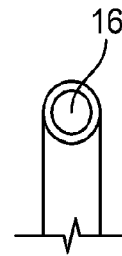

FIG. 2b

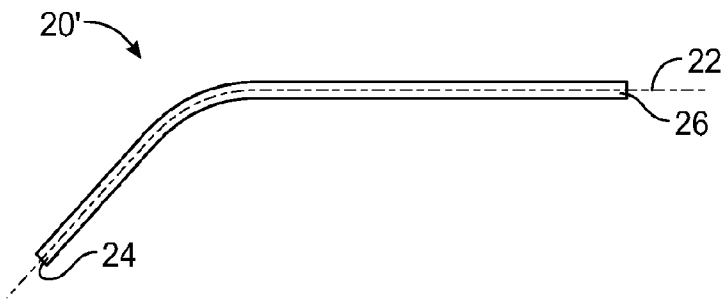

FIG. 3a

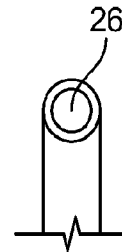

FIG. 3b

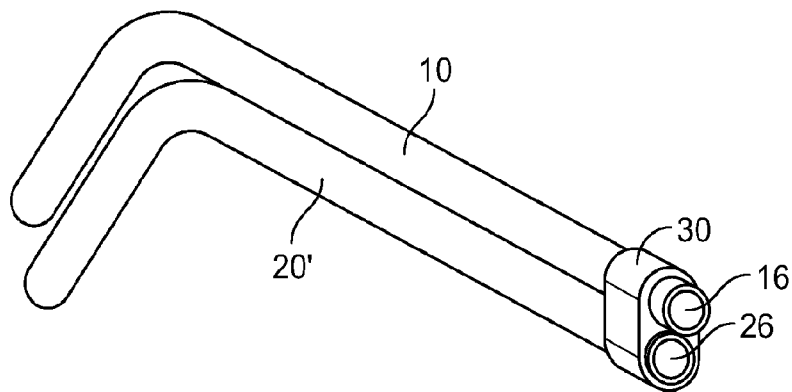

FIG. 4

3/11

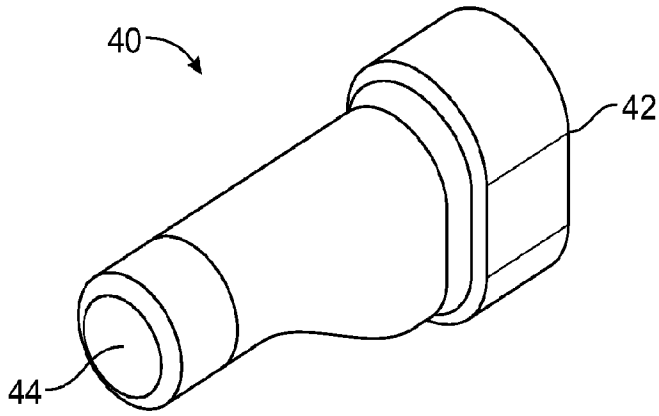

FIG. 5a

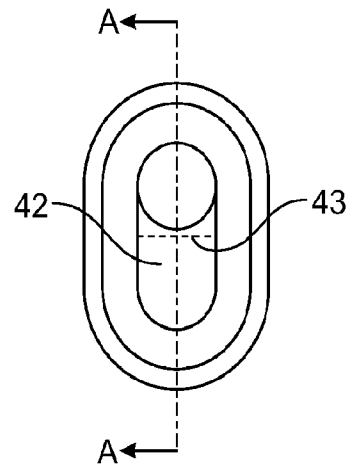

FIG. 5b

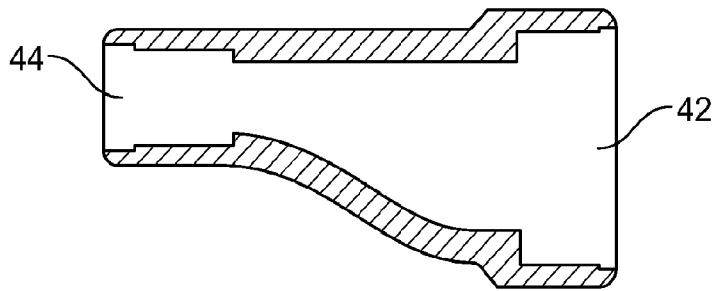

FIG. 5c

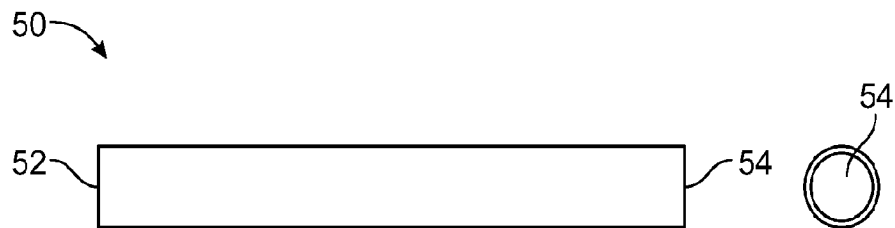

FIG. 6

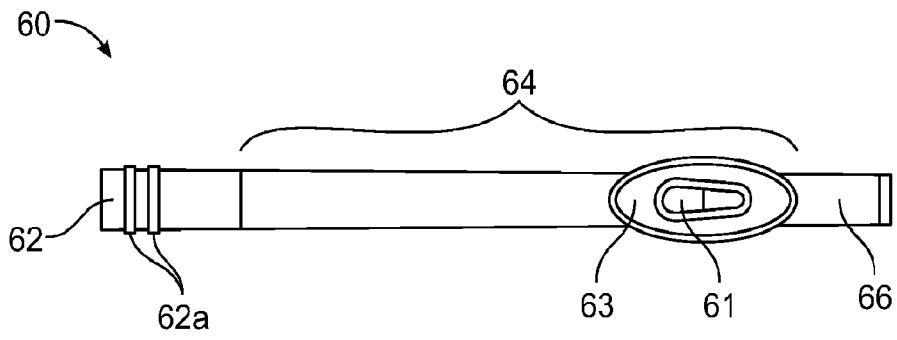

FIG. 7a

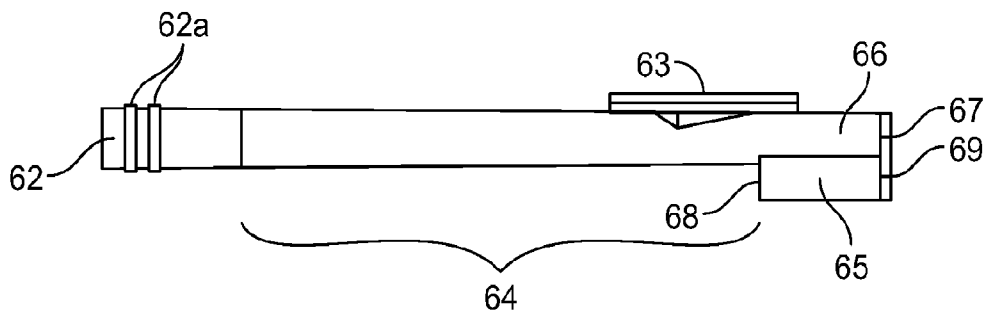

FIG. 7b

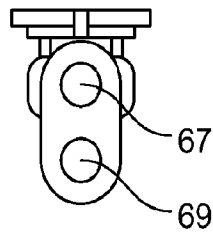

FIG. 7c

5/11

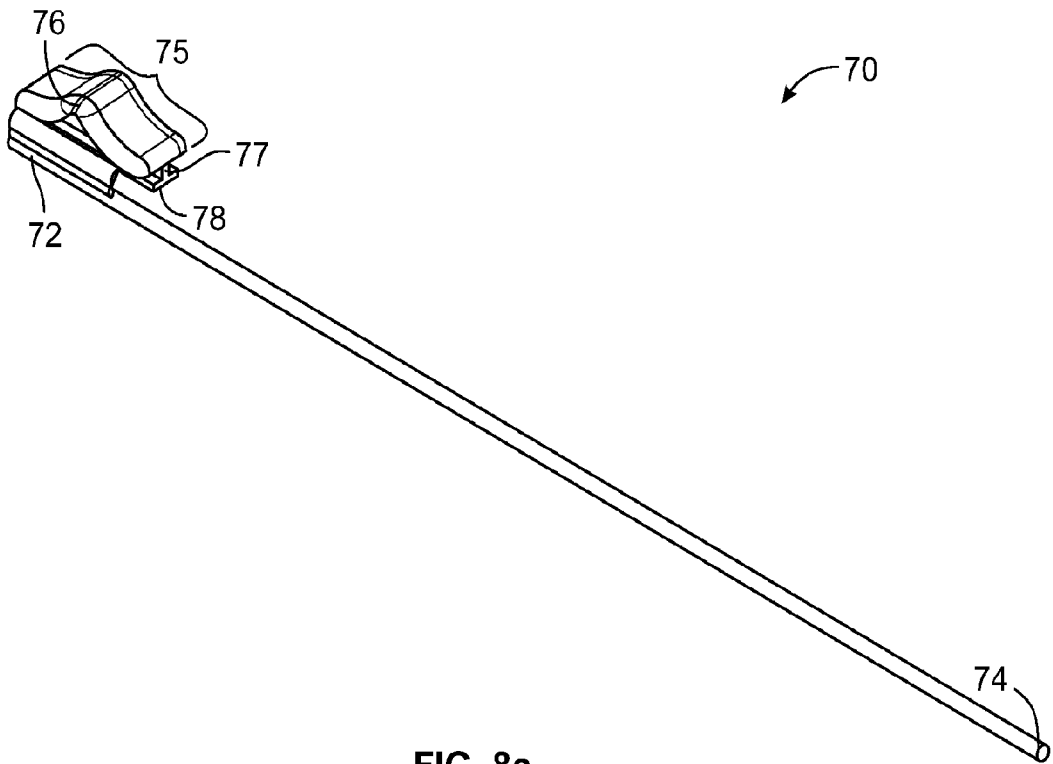

FIG. 8a

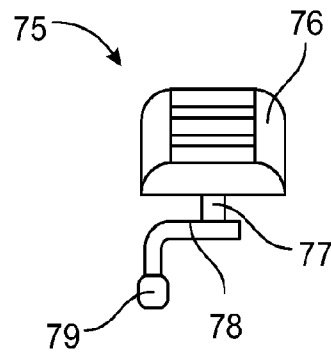

FIG. 8b

6/11

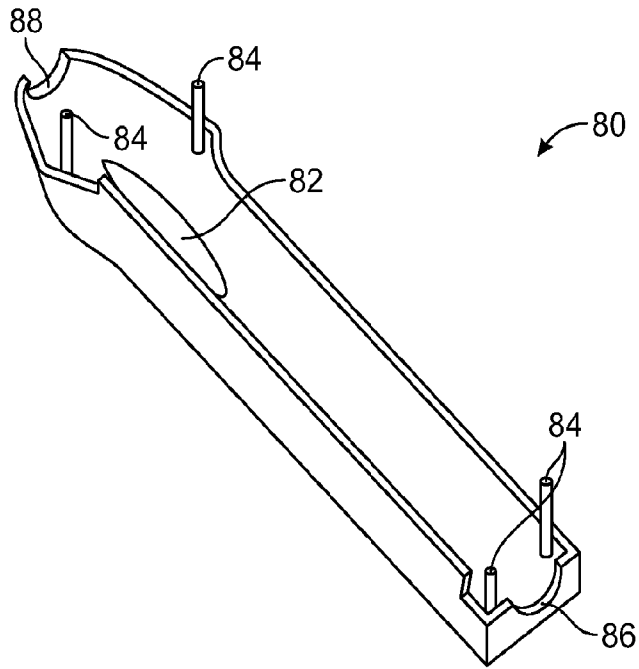

FIG. 9

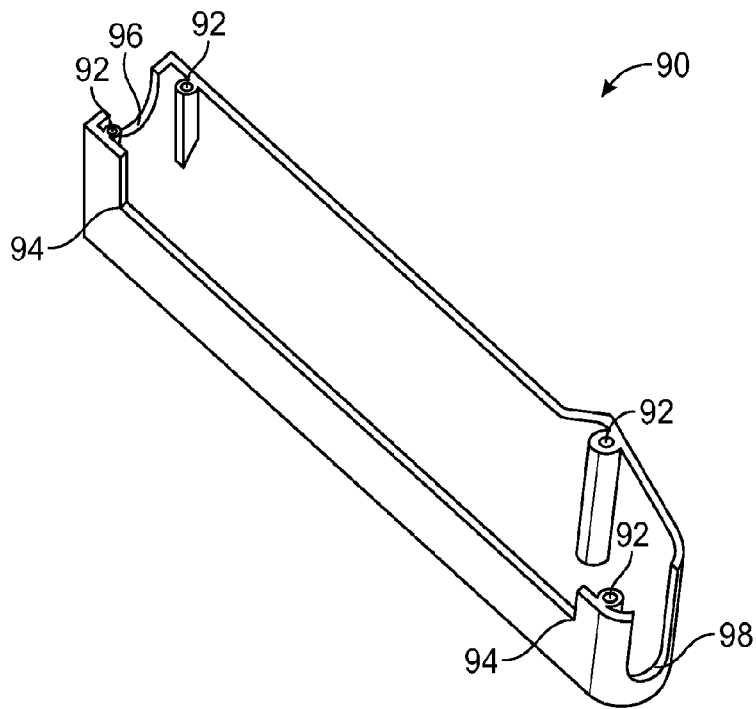

FIG. 10

7/11

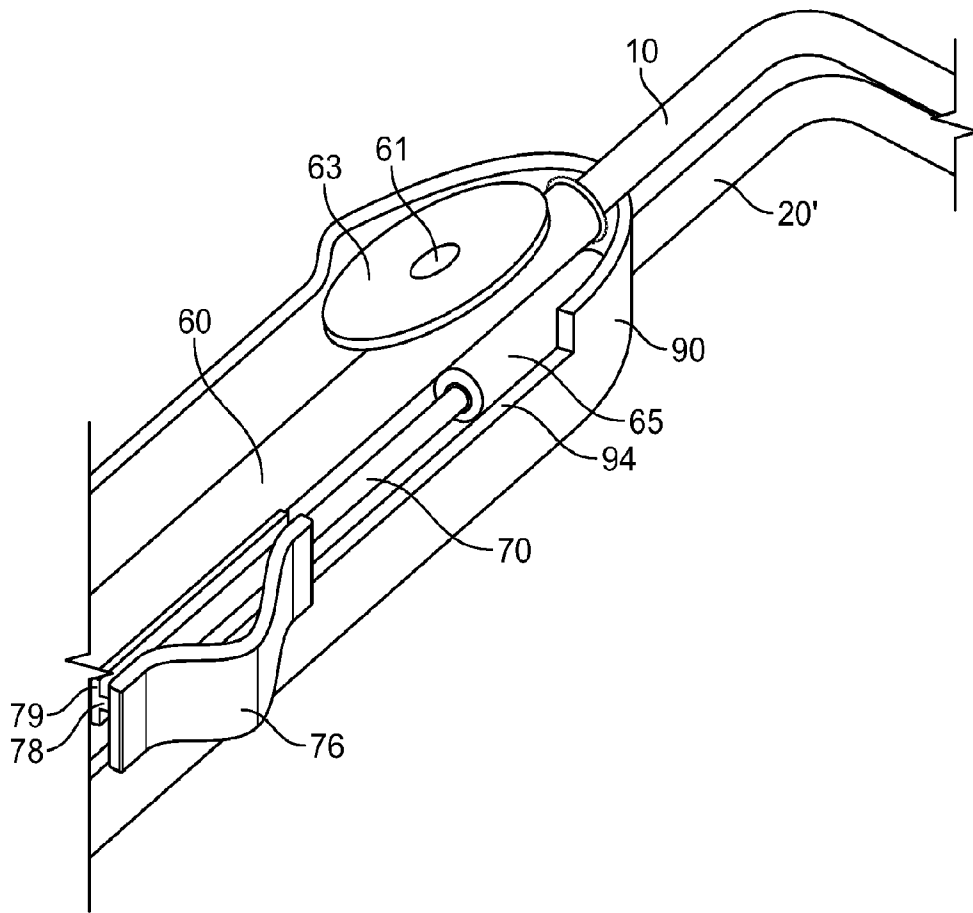

FIG. 11

8/11

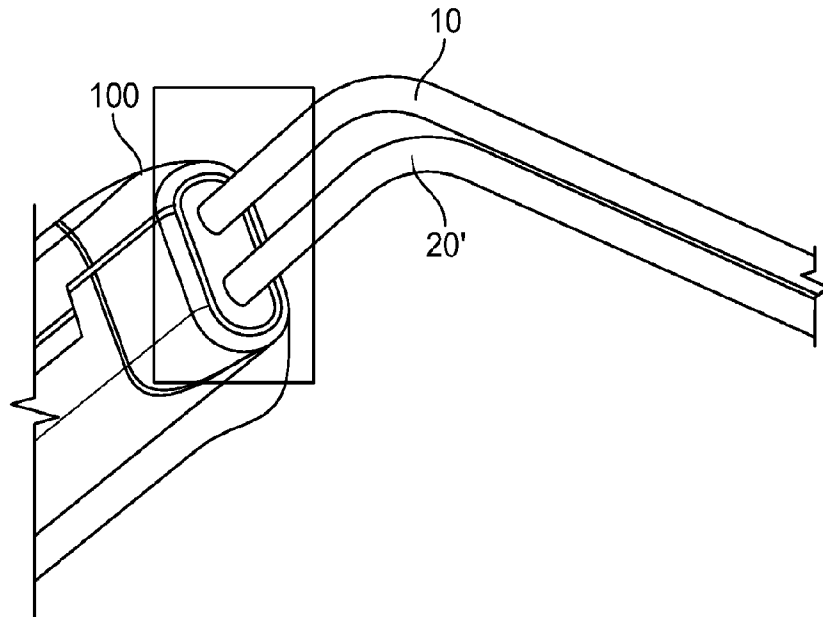

FIG. 12

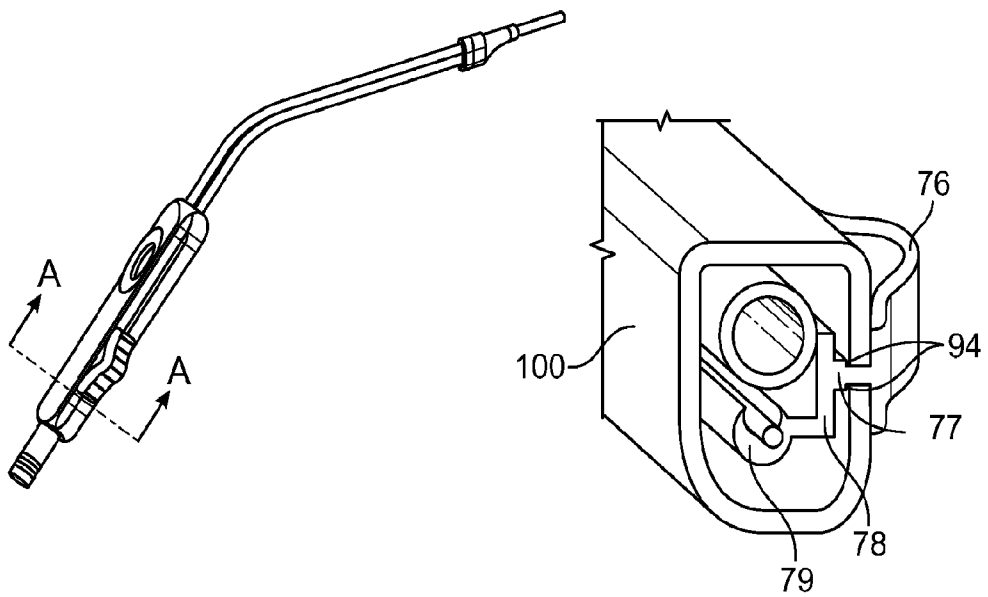

FIG. 13

SECTION A-A

9/11

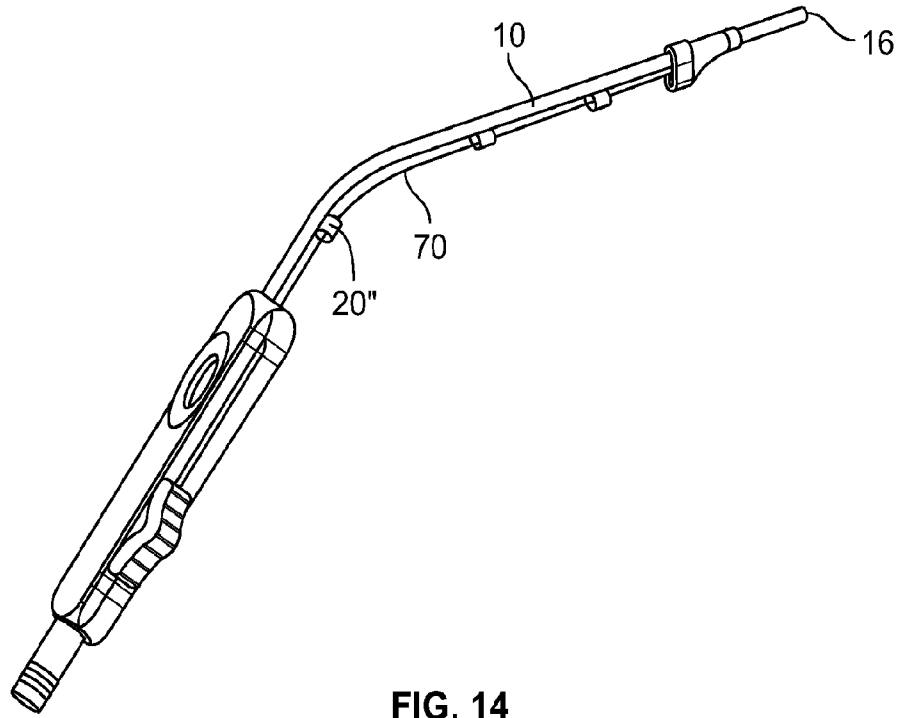

FIG. 14

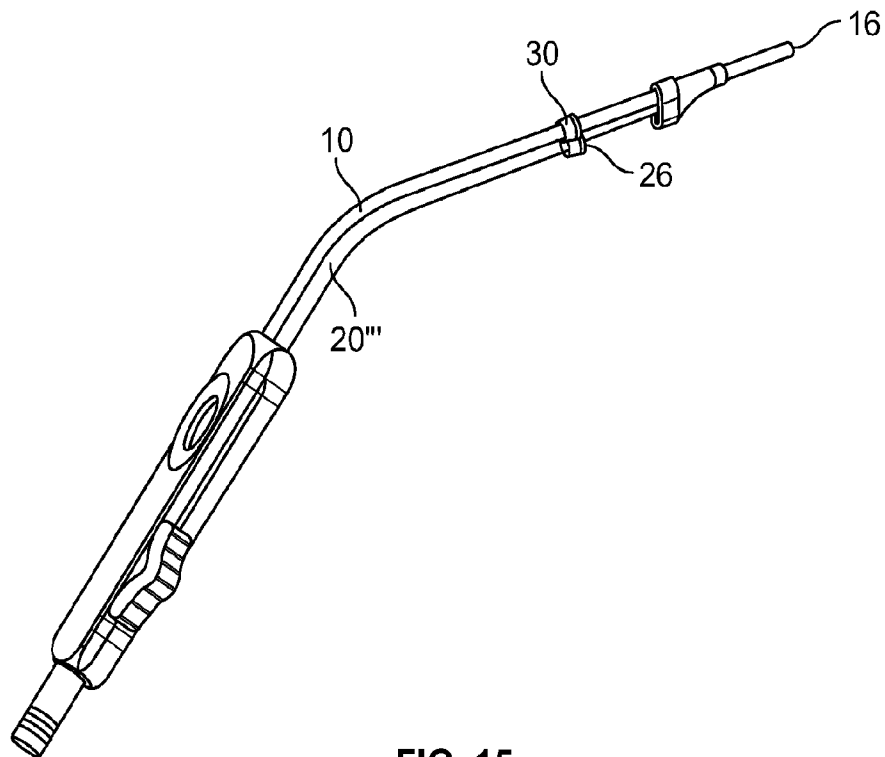

FIG. 15

10/11

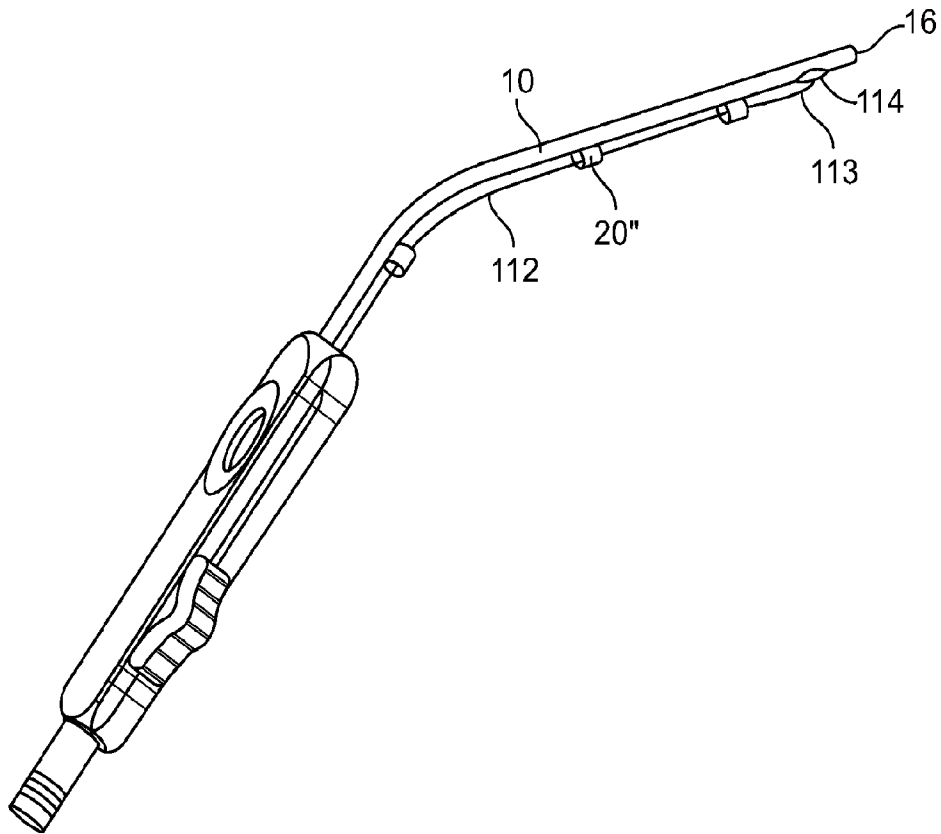

FIG. 16

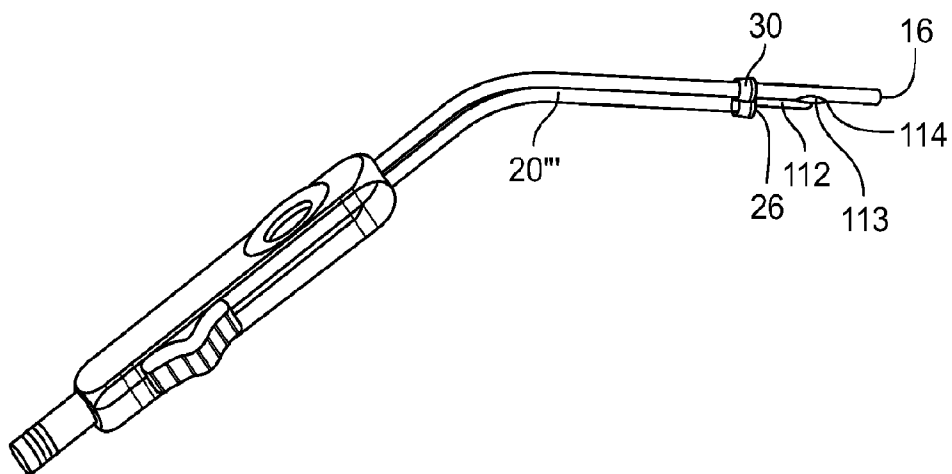

FIG. 17

11/11

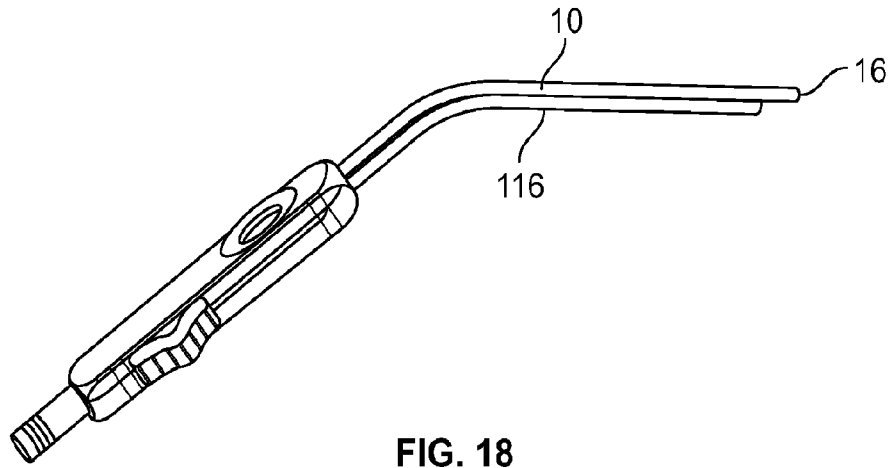

FIG. 18

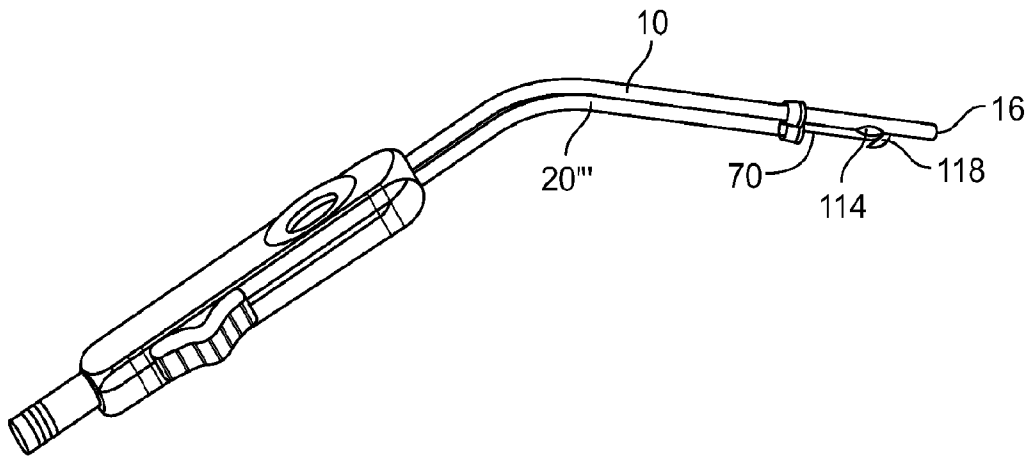

FIG. 19

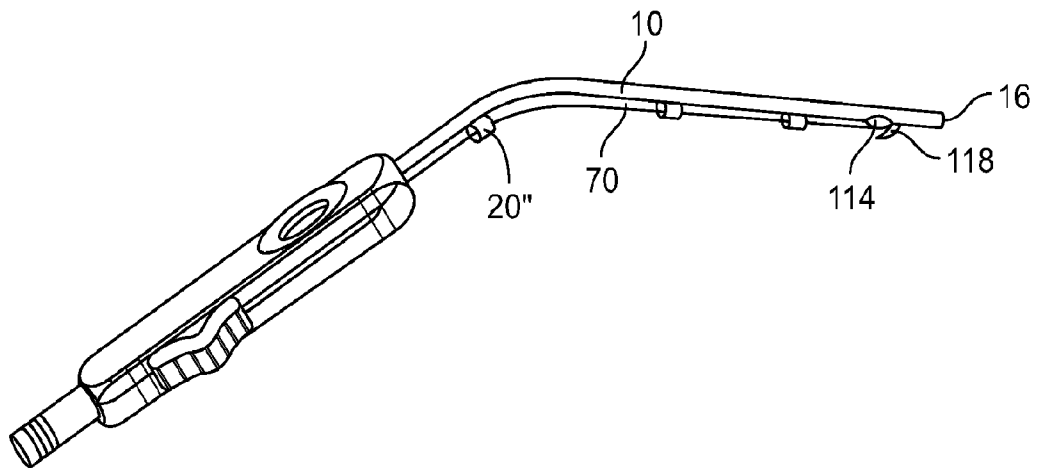

FIG. 20