

(19) World Intellectual Property Organization
International Bureau



(43) International Publication Date
11 May 2006 (11.05.2006)

PCT

(10) International Publication Number
WO 2006/049512 A2

(51) International Patent Classification: Not classified

(21) International Application Number:
PCT/NZ2005/000289

(22) International Filing Date:
1 November 2005 (01.11.2005)

(25) Filing Language: English

(26) Publication Language: English

(30) Priority Data:
60/624,425 2 November 2004 (02.11.2004) US

(71) Applicant (for all designated States except US): FISHER & PAYKEL APPLIANCES LIMITED [NZ/NZ]; 78 Springs Road, East Tamaki, 1706 Auckland (NZ).

(72) Inventors; and

(75) Inventors/Applicants (for US only): WHITE, David, Julian [NZ/NZ]; 307A Maxted Road Ramarama, 1850 Auckland (NZ). MCGILL, Ian, Campbell [NZ/NZ]; 88 Kohimarama Road, 1005 Auckland (NZ).

(74) Agents: ADAMS, Matthew, D. et al.; A J Park, Huddart Parker Building, 6th Floor, P.O. Box 949, 6015 Wellington (NZ).

(81) Designated States (unless otherwise indicated, for every kind of national protection available): AE, AG, AL, AM, AT, AU, AZ, BA, BB, BG, BR, BW, BY, BZ, CA, CH, CN, CO, CR, CU, CZ, DE, DK, DM, DZ, EC, EE, EG, ES, FI, GB, GD, GE, GH, GM, HR, HU, ID, IL, IN, IS, JP, KE, KG, KM, KN, KP, KR, KZ, LC, LK, LR, LS, LT, LU, LV, LY, MA, MD, MG, MK, MN, MW, MX, MZ, NA, NG, NI, NO, NZ, OM, PG, PH, PL, PT, RO, RU, SC, SD, SE, SG, SK, SL, SM, SY, TJ, TM, TN, TR, TT, TZ, UA, UG, US, UZ, VC, VN, YU, ZA, ZM, ZW.

(84) Designated States (unless otherwise indicated, for every kind of regional protection available): ARIPO (BW, GH, GM, KE, LS, MW, MZ, NA, SD, SL, SZ, TZ, UG, ZM, ZW), Eurasian (AM, AZ, BY, KG, KZ, MD, RU, TJ, TM), European (AT, BE, BG, CH, CY, CZ, DE, DK, EE, ES, FI, FR, GB, GR, HU, IE, IS, IT, LT, LU, LV, MC, NL, PL, PT, RO, SE, SI, SK, TR), OAPI (BF, BJ, CF, CG, CI, CM, GA, GN, GQ, GW, ML, MR, NE, SN, TD, TG).

Published:

— without international search report and to be republished upon receipt of that report

For two-letter codes and other abbreviations, refer to the "Guidance Notes on Codes and Abbreviations" appearing at the beginning of each regular issue of the PCT Gazette.

(54) Title: PISTON ROD CONNECTION FOR LINEAR COMPRESSOR

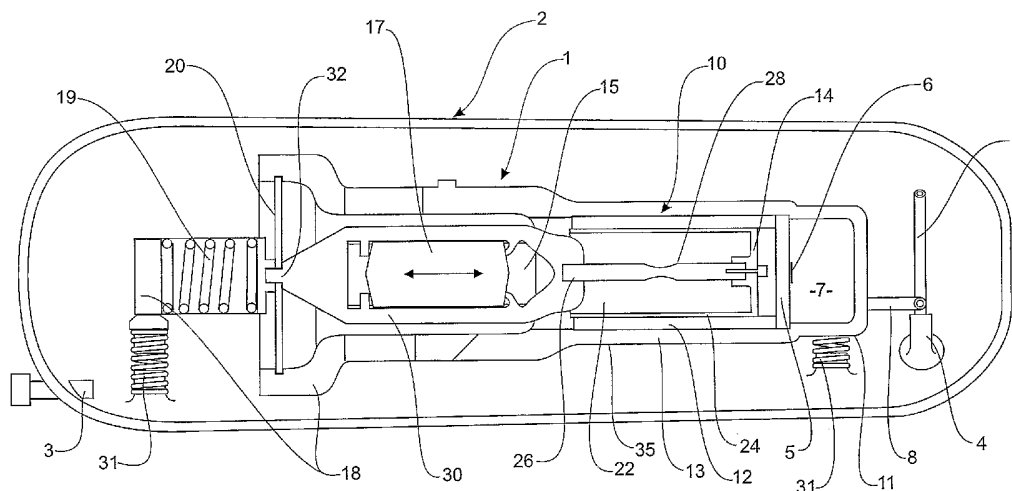

(57) Abstract: The present invention relates to a linear compressor having a piston rod and a hollow piston with a cylindrical wall and a crown. A connection between the end of the piston rod and the crown includes an aperture in the piston crown extending from an outer face to an inner face. The piston rod includes an axial hollow extending into one end. The hollow is of size similar to but not larger than the size of the aperture in the piston crown. A pin has a shank that extends through the aperture into the hollow. The end of the piston rod contacts the crown adjacent to the aperture. The pin exhibits a frictional engagement with the hollow of the piston rod to engage the end of the piston rod to the piston crown.

WO 2006/049512 A2

“PISTON ROD CONNECTION FOR LINEAR COMPRESSOR”**FIELD OF THE INVENTION**

The present invention relates to linear compressors, and in particular linear compressors
5 of the type suitable for use in a vapour compression refrigeration system.

BACKGROUND TO THE INVENTION

Linear compressors of a type for use in a vapour compression refrigeration system are
the subject of many documents in the prior art. One such document is our co-pending PCT
10 patent application PCT/NZ2004/000108. That specification describes a variety of
developments relating to such compressors, many of which have particular application to the
linear compressors. The present invention relates to further improvements to compressor
embodiments such as are described in that patent application which provides a general
exemplification of a compressor to which the present invention may be applied. However the
15 present may also be applied beyond the scope of the particular embodiments of a linear
compressor disclosed in that application. Persons skilled in the art will appreciate the general
application of the ideas herein to other embodiments of linear compressors such as are found in
the prior art.

The present invention relates generally to connection of a piston rod or connecting
20 member to the crown of a hollow piston.

SUMMARY OF THE INVENTION

It is an object of the present invention to provide an improved connection between a
piston rod and the crown of a hollow piston with particular application to linear compressors.

25 In a first aspect the invention may broadly be said to consist in a linear compressor
having a piston rod and a hollow piston with a cylindrical wall and an enclosing crown, the
improvement comprising a connection between an end of said piston rod and said crown
wherein said crown includes an aperture of a first size extending from an outer face to an inner
face, said piston rod includes an axial hollow of a second size in cross-section extending into
30 one end, said second size being similar to but not larger than said size of said aperture in said
piston crown, and a pin has a shank that extends through said aperture into said hollow, with the
end of said piston rod contacting said crown adjacent said aperture, said pin exhibiting a
frictional engagement with at least said hollow of said piston rod and engaging said end of said
piston rod to said piston crown.

According to a further aspect of the invention said pin includes a flange adjacent the outer face of said piston crown, said flange being larger than said aperture and preventing said pin passing fully into said aperture. Alternatively if the pin may have a driving fit in the aperture, or the pin may expand the piston rod end to engage features on the inner face of the piston crown. In either of these cases neither flange nor driving fit are required to retain the piston rod to the crown. However a flange may still be present to secure a valve member to the piston crown.

According to a further aspect of the invention said piston crown includes features on its inner face defining one or more surrounding surfaces facing inwardly toward said aperture to collectively define a socket for the end of said piston rod, and said end of said piston rod is compressed or gripped between said shank of said pin and said inwardly facing surface or surfaces.

According to a further aspect of the invention said inwardly facing surface or surfaces is defined by an inward cylindrical surface of an annular upstand wall extending from the inner face of the piston crown surrounding said aperture.

According to a further aspect of the invention said end of said piston rod is divided into a plurality of fingers surrounding said hollow with said fingers gripped between said shank of said pin and said inward surfaces.

According to a further aspect of the invention a planar suction valve is secured to said piston crown with a portion thereof located between a flange of said pin and the surface of said crown adjacent said aperture, said pin passing through an aperture in said valve member.

In a further aspect the invention may broadly be said to consist in a method of securing a piston to a piston rod, said piston having a piston crown with an aperture of a first size, and said piston rod having an end with a hollow of a second size, said method comprising the step of driving a pin having a shank which is of a size to have a close fit through said aperture and a driving fit into said hollow, through said aperture into said hollow until said piston crown is secured against said end of said piston rod.

According to a further aspect of the invention said piston crown includes on its inner face, features having one or more surrounding surfaces facing inwardly toward said aperture to collectively define a socket, and said method includes the step of fitting said end of said piston rod into said socket of said piston crown prior to driving said pin through said aperture.

To those skilled in the art to which the invention relates, many changes in construction and widely differing embodiments and applications of the invention will suggest themselves without departing from the scope of the invention as defined in the appended claims. The

disclosures and the descriptions herein are purely illustrative and are not intended to be in any sense limiting.

BRIEF DESCRIPTION OF THE DRAWINGS

5 Figure 1 is a side elevation in cross-section of a refrigeration compressor including a linear compressor suspended in a housing.

Figure 2 is a cross-sectional side elevation of the relevant portion of the piston to piston rod assembly according to the preferred embodiment of the present invention.

10 Figure 3 is a side elevation of a pin or rivet according to the preferred embodiment of the present invention.

Figure 4 is a cross-sectional side elevation of a piston rod member according to a preferred embodiment of the present invention.

Figure 5 is an end elevation of the piston rod member of Figure 4.

Figure 6 is an end elevation of the inside of the piston crown.

15

DETAILED DESCRIPTION

Referring to Figure 1 the compressor for a vapour compression refrigeration system includes a linear compressor 1 supported inside a housing 2. Typically the housing 2 is hermetically sealed and includes a gases inlet port 3 and a compressed gases outlet port 4. 20 Uncompressed gases flow within the interior of the housing, surrounding the compressor 1. These uncompressed gases are drawn into the compressor during intake stroke, compressed between the piston crown 14 and outlet valve plate 5 on the compression stroke and expelled through discharge valve 6 into a compressed gases manifold 7. Compressed gases exit the manifold 7 to the outlet port 4 in the shell through a flexible tube 8. To reduce the stiffness 25 effect of discharge tube 8 the tube is preferably arranged as a loop or spiral transverse to the reciprocating axis of the compressor.

The intake to the compression space may be through the piston (with an aperture and valve in the crown) or through the head, divided to include suction and discharge manifolds and valves.

30 The illustrated linear compressor 1 has, broadly speaking, a cylinder part and a piston part connected by a main spring. The cylinder part includes cylinder chassis 10, cylinder head 11, valve plate 5 and a cylinder liner 12. The cylinder part also includes stator parts 15 for a linear electric motor. An end portion 18 of the cylinder part, distal from the head 11, mounts

the main spring relative to the cylinder part. In the illustrated embodiment the main spring is formed as a combination of coil spring 19 and flat spring 20.

The piston part includes a hollow piston 22 with sidewall 24 and crown 14. A rod 26 connects between the crown 14 and a supporting body 30 for linear motor armature 17. The rod
5 has a flexible portion 28 in approximately the centre of the hollow piston 22. The linear motor armature 17 comprises a body of permanent magnet material (such as ferrite or neodymium) magnetised to provide one or more poles directed transverse to the axis of reciprocation of the piston within the cylinder liner. An end portion 32 of armature support 30 which is distal from the piston 22 is connected with the main spring 19, 20.

10 The linear compressor 1 is mounted within the shell 2 on a plurality of suspension springs to isolate it from the shell. In use the large outer body of the linear compressor, the cylinder part, will oscillate along the axis of reciprocation of the piston part within the cylinder part. In the preferred compressor the piston part is purposely kept very light compared to the cylinder part so that the oscillation of the cylinder part is small compared with the relative
15 reciprocation between the piston part and cylinder part. In the illustrated form the linear compressor is mounted on a set of four suspension springs 31 generally positioned around the periphery. Alternate suspension spring arrangements are illustrated in PCT/NZ2004/000108. The ends of each suspension spring fit over elastomeric snubbers connected with the linear compressor 1 at one end of each spring and connected with the compressor shell 2 at the other
20 end of each spring.

This briefly describes a linear compressor of a type for which the improved piston crown to piston rod connection of the present invention is useful. However it will be appreciated that the usefulness of the present invention is not restricted to linear compressors of the type and configuration illustrated. The improvement is generally applicable.

25 According to the present invention a rivet or pin is used to secure the piston to the end of the piston rod. This avoids using any screw type joint which can become unscrewed through small rotations of the piston induced by extension of the main spring.

The preferred arrangement is best described with reference to Figures 2 to 6 where a portion of the piston crown 14 is shown secured to an end of the piston rod 26. The piston
30 crown includes a small central aperture 42. The piston rod 26 includes a central hollow 44 extending in from one end. A rivet or pin 45 has a shank 46 that preferably has a transition fit through the aperture 42 and a driving fit within the hollow 44. The pin 45 is driven through the aperture 42 to engage in the hollow 44 and hold the piston crown 14 to the piston rod 26.

Preferably the pin 45 has a head 47 with an outward flange to engage on the outer face of piston crown 14. The flange may also retain a planar valve member 52 against the outer surface of the piston crown. Alternatively the shank 46 of the pin 45 may be also a driving fit within aperture 42 and/or may cause the end of piston rod 26 to expand and engage features on the inner side of piston crown 14.

Preferably an annular upstand wall 48 protrudes from the inner side of the piston crown 14, defining an inwardly facing cylindrical surface surrounding the aperture 42. Preferably the outer surface of the end of the piston rod 26 is an interference fit within this annular wall 48. The piston rod may be terminated with a slight chamfer to aid pushing the piston rod end into this socket. Preferably the piston rod end is formed, around said hollow 44, as a plurality of fingers, for example by two or more longitudinal slots 50. With the pin 46 driven into the hollow 44 the fingers are splayed apart so that the outer surface of the fingers engages against the inner surface of the annular wall 48.

By these means there is a friction force created between the rivet and the rod and between the rod and the socket. The force required to separate the rod from the piston is significantly greater than the rivet insertion force or the piston insertion force into the socket. It is intended that the pin is a "heavy drive" fit into the hollow end of the piston rod, requiring, for example, a 200N drive force to insert a pin approximately 10mm long with a 2mm shank diameter. Additional security of the joint can be achieved by applying adhesives before assembly. A suitable adhesive may include epoxy or cyanoacrylate for example.

Typically the piston will be constructed with a sintered steel crown and a steel tube cylindrical wall, the two components being brazed or welded together. The piston rod and the connecting pin may both be formed of suitable steel alloys.

CLAIMS:

1. A linear compressor having a piston rod and a hollow piston with a cylindrical wall and a crown, the improvement comprising a connection between an end of said piston rod and said crown wherein said crown includes an aperture of a first size (in cross-section) extending from an outer face to an inner face, said piston rod includes an axial hollow of a second size (in cross-section) extending into one end, said second size being similar to but not larger than said size of said aperture in said piston crown, and
- 5 a pin has a shank that extends through said aperture into said hollow, with the end of said piston rod contacting said crown adjacent said aperture, said pin exhibiting a frictional engagement with at least said hollow of said piston rod and engaging said end of said piston rod to said piston crown.
- 10
2. A linear compressor as claimed in claim 1, wherein said pin includes a flange adjacent the outer face of said piston crown, said flange being larger than said aperture and preventing said pin passing fully into said aperture.
- 15
3. A linear compressor as claimed in either claims 1 or claim 2 wherein the pin has a driving fit in the aperture.
- 20
4. A linear compressor as claimed in any one of claims 1 to 3, wherein the pin expands the piston rod end to engage features on the inner face of the piston crown.
5. A linear compressor as claimed in any one of claims 1 to 3, wherein said piston crown includes features on its inner face defining one or more surrounding surfaces facing inwardly toward said aperture to collectively define a socket for the end of said piston rod, and
- 25 said end of said piston rod is compressed or gripped between said shank of said pin and said inwardly facing surface or surfaces.
- 30
6. A linear compressor as claimed in claim 5, wherein said inwardly facing surfaces are defined by an inward cylindrical surface of an annular upstand wall extending from the inner face of the piston crown surrounding said aperture.

7. A linear compressor as claimed in either claims 5 or claim 6, wherein said end of said piston rod is divided into a plurality of fingers surrounding said hollow with said fingers gripped between said shank of said pin and said inward surfaces.
- 5 8. A linear compressor as claimed in any one of claims 1 to 7, wherein a planar suction valve is secured to said piston crown with a portion thereof located between a flange of said pin and the surface of said crown adjacent said aperture, said pin passing through an aperture in said valve member.
- 10 9. A method of securing a piston to a piston rod, said piston having a piston crown with an aperture of a first size, and said piston rod having an end with a hollow of a second size, said method comprising:
the step of driving a pin having a shank which is of a size to have a close fit through said aperture and a driving fit into said hollow, through said aperture, into said hollow, until said
15 piston crown is secured against said end of said piston rod.
10. A method as claimed in claim 9, wherein said piston crown includes on its inner face, features having one or more surrounding surfaces facing inwardly toward said aperture to collectively define a socket, and
20 said method includes the step of fitting said end of said piston rod into said socket of said piston crown prior to driving said pin through said aperture.
11. In a linear compressor, a connection between a piston and a piston crown, said connection being substantially as herein described with reference to and as illustrated by
25 Figures 2 to 6 of the accompanying drawings.
12. A method of securing a piston to a piston rod, said method being substantially as described with reference to the drawings.

1/2

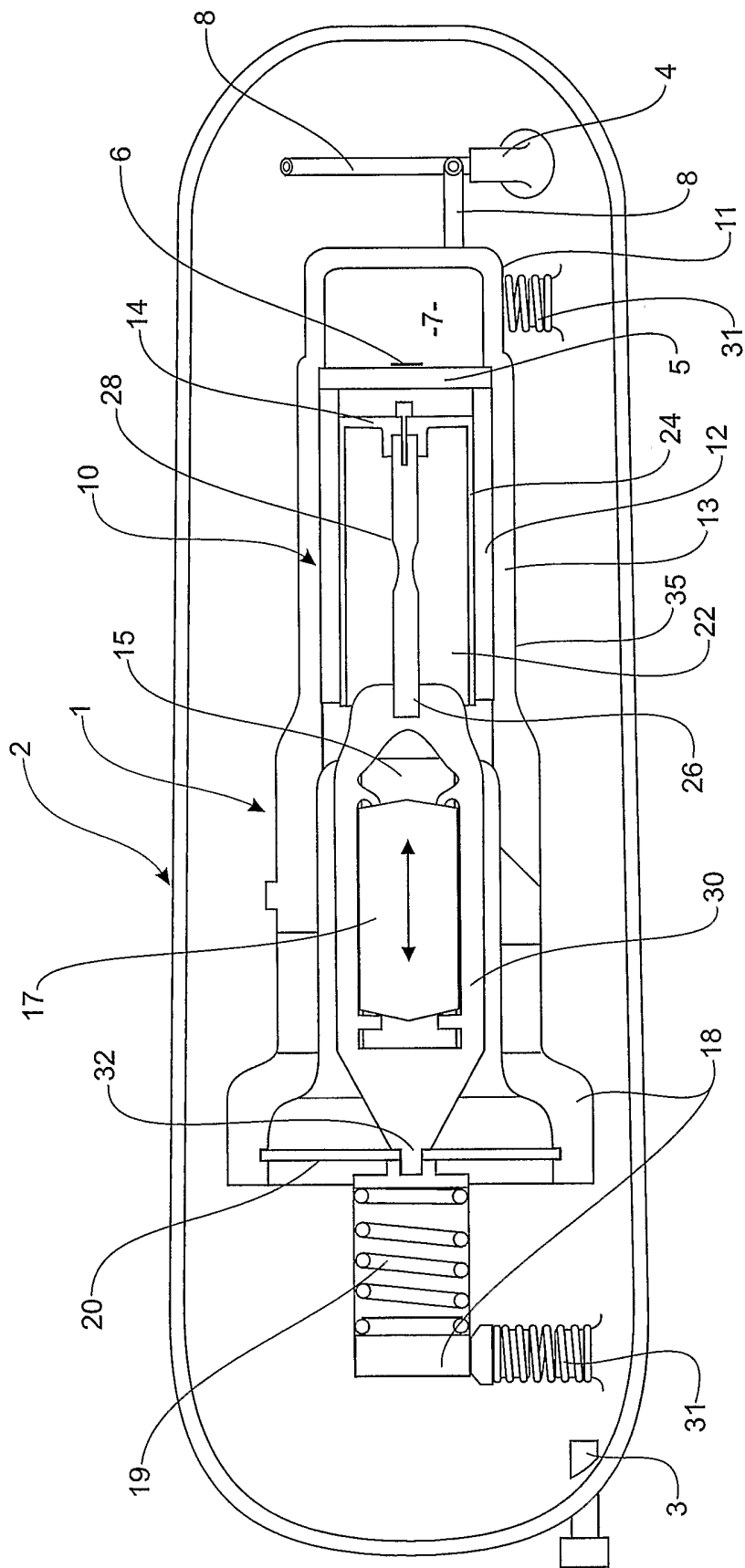

FIGURE 1

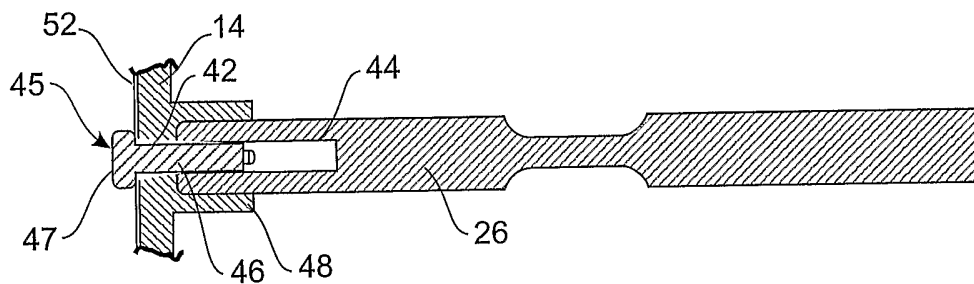

FIGURE 2

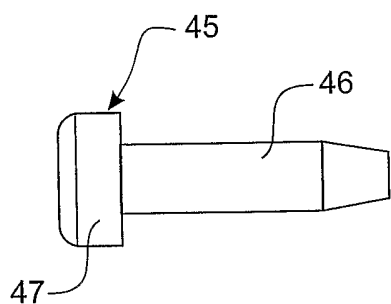

FIGURE 3

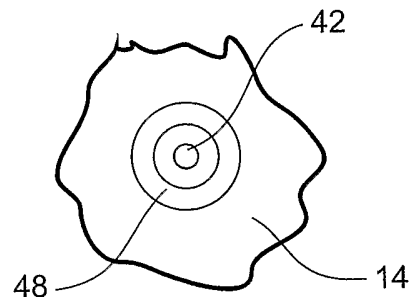

FIGURE 6

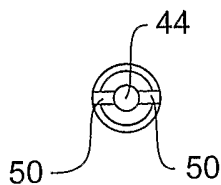

FIGURE 5

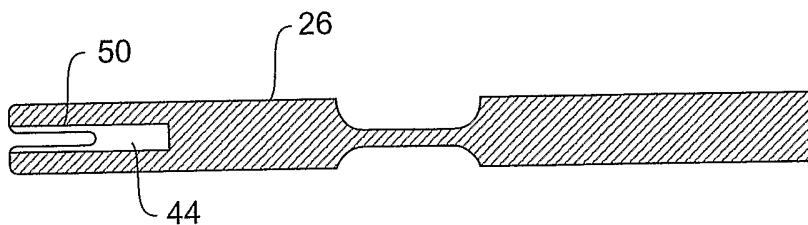

FIGURE 4