



INTERNATIONAL APPLICATION PUBLISHED UNDER THE PATENT COOPERATION TREATY (PCT)

<p>(51) International Patent Classification ⁵ : B60H 1/00, G05D 23/19</p>	<p>A1</p>	<p>(11) International Publication Number: WO 94/18021 (43) International Publication Date: 18 August 1994 (18.08.94)</p>
<p>(21) International Application Number: PCT/SE93/00103 (22) International Filing Date: 11 February 1993 (11.02.93) (71) Applicant (for all designated States except US): SAAB AUTOMOBILE AKTIEBOLAG [SE/SE]; S-461 80 Trollhättan (SE). (72) Inventors; and (75) Inventors/Applicants (for US only): KNUTSON, Anders, M. [SE/SE]; Kungsgatan 18, III, S-461 31 Trollhättan (SE). KIRCHNER, Wolfgang [DE/DE]; Stuttgarterstrasse 15, D-7024 Filderstadt 4 (DE). (74) Agent: FURHEM, Hans; Saab-Scania AB, Scania Trucks & Buses, Patents, S-151 87 Södertälje (SE).</p>	<p>(81) Designated States: DE, GB, US. Published With international search report.</p>	

(54) Title: AN APPARATUS AND METHOD FOR THE ENVIRONMENTAL CONTROL OF VEHICLE INTERIORS

(57) Abstract

An apparatus and method for controlling the air condition and heating within a vehicle interior compartment. The system includes a fan (13), heat exchangers (14, 15), temperature sensors (26, 27, 28) and a solar sensor (29) and temperature control (47) for setting a desired temperature. The system includes a control unit (47) which is operative to calculate a theoretical interior temperature T_I based only upon information from sensors (26, 29) sensing the external heat load on the compartment, a sensor (27) sensing the temperature on the air supplied to the compartment and blowerfan current representative of the volume of air supplied to the compartment. The control unit (47) compares this theoretical interior temperature T_I with the preset temperature T_{Iset} , calculates the difference ΔT_I , and then controls air flow and mixed temperature T_M to readjust or maintain the interior temperature within the compartment (19) in level with the preset temperature T_{Iset} .

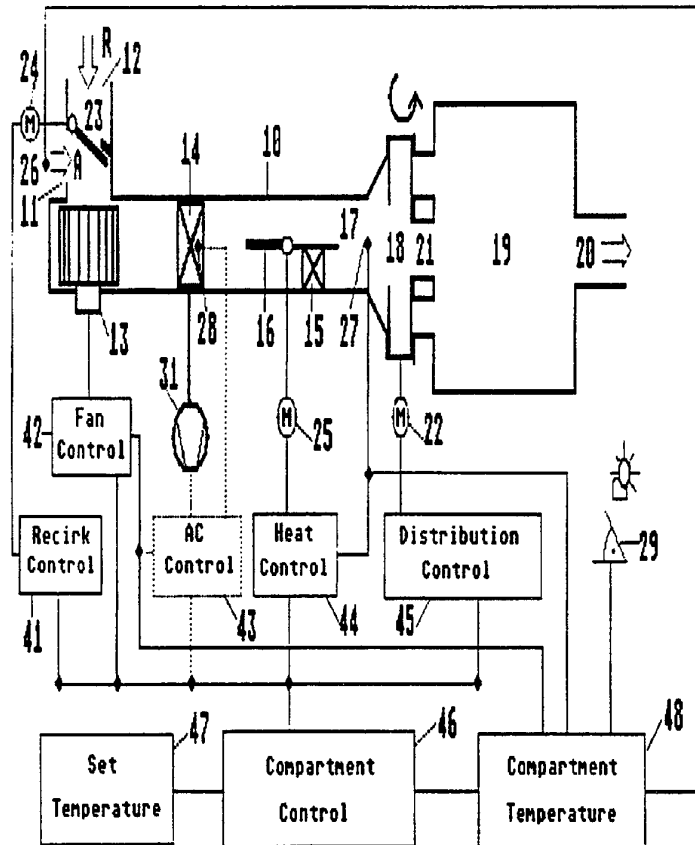

FOR THE PURPOSES OF INFORMATION ONLY

Codes used to identify States party to the PCT on the front pages of pamphlets publishing international applications under the PCT.

AT	Austria	GB	United Kingdom	MR	Mauritania
AU	Australia	GE	Georgia	MW	Malawi
BB	Barbados	GN	Guinea	NE	Niger
BE	Belgium	GR	Greece	NL	Netherlands
BF	Burkina Faso	HU	Hungary	NO	Norway
BG	Bulgaria	IE	Ireland	NZ	New Zealand
BJ	Benin	IT	Italy	PL	Poland
BR	Brazil	JP	Japan	PT	Portugal
BY	Belarus	KE	Kenya	RO	Romania
CA	Canada	KG	Kyrgyzstan	RU	Russian Federation
CF	Central African Republic	KP	Democratic People's Republic of Korea	SD	Sudan
CG	Congo	KR	Republic of Korea	SE	Sweden
CH	Switzerland	KZ	Kazakhstan	SI	Slovenia
CI	Côte d'Ivoire	LI	Liechtenstein	SK	Slovakia
CM	Cameroon	LK	Sri Lanka	SN	Senegal
CN	China	LU	Luxembourg	TD	Chad
CS	Czechoslovakia	LV	Latvia	TG	Togo
CZ	Czech Republic	MC	Monaco	TJ	Tajikistan
DE	Germany	MD	Republic of Moldova	TT	Trinidad and Tobago
DK	Denmark	MG	Madagascar	UA	Ukraine
ES	Spain	ML	Mali	US	United States of America
FI	Finland	MN	Mongolia	UZ	Uzbekistan
FR	France			VN	Viet Nam
GA	Gabon				

An apparatus and method for the environmental control of Vehicle interiors

Field

5 This invention relates to an apparatus and method for the environmental control of the interior space of a motor vehicle and in particular to the maintenance of air temperatures at predetermined temperature levels.

Background

10 Most vehicles are now equipped with air conditioning and heating systems for maintaining the air within the vehicle passenger compartment at a set desired temperature value.

15 In order to maintain the temperature at the desired value is it typically necessary to detect the ambient (external) air temperature, the internal air temperature, mixed air temperature (that is the temperature of air immediately prior to discharge into the vehicle interior) and to control the air flow and distribution within the compartment based on the detected parameters. More advanced systems also use a sunsensor to detect the
20 thermal load of the compartment.

The interior space temperature at various locations are depending on the thermal load of the interior space. It is therefore difficult to obtain a representative value of the temperature within a passenger compartment.
25 The thermal load of the interior space depend on the heat quantity introduced thereinto or discharged therefrom due to differencies in temperature between outside air temperature and inside air temperature, the heat quantity absorbed thereinto as solar heat, the heat radiated from the passengers bodies, the heat quantity absorbed thereinto from the
30 engine and electrical equipment and the heat quantity introduced or discharged therefrom due to the air-conditioning and heating system.
Furthermore, depending on the different temperatures, air-flow speed and the direction of the airflow introduced into the interior space, to maintain the appropriate preset value, makes it severe to servey a valid interior
35 space temperature.

In order to ideally monitor the heat distribution within the passenger compartment it is necessary to use more than one temperature sensor for control of the heating system in order to maintain the appropriate preset temperature. Such a temperature sensor is often connected to an air-pump, in order to obtain an sufficient circulation of air around the sensor. Even though an air-pump is used for circulating the air around the temperature sensor, most unreliable readings could be obtained due to local heat sources e.t.c around the temperature sensor. The control of the temperature in the passenger compartment could therefore be severely affected, especially if the control strategy basically is dependent of the readings from the interior temperature sensor. Temperature sensors are also relatively expensive and produces noise inside the vehicle. All of these things must be taken into consideration when designing a climate control system, therefor it is desirable to eliminate the interior space temperature sensor.

Objective of invention

The present invention provides an environmental control system for the interior of a motor vehicle in which the above problems have been eliminated since the control system does not use any temperature sensor within the vehicle interior.

The system includes a control unit which is operative to calculate a theoretical interior temperature T_I based only upon information from sensors sensing the external heat load on the compartment and the temperature on the air and volume of air supplied to the compartment , and compares this theoretical interior temperature T_I with the preset temperature $T_{I\text{Set}}$ calculates the difference ΔT_I , and then controls air flow and mixed temperature T_M to readjust or maintain the interior temperature within the compartment in level with the preset temperature $T_{I\text{Set}}$.

The inventive concept enables usage of temperature values only from temperature sensors so arranged that they are naturally exposed by the conditioning and heating system to a sufficient air-flow, thus enabling an accurate temperature reading, and the external heat load sensed by a solar radiation sensor.

Summary of Invention

Accordingly there is provided an apparatus for environmental control of interior of a motor vehicle, the apparatus comprising an ambient air temperature sensor for monitoring ambient air temperature, a radiation
5 sensor for measuring the intensity of radiation entering the interior of the vehicle, a mixed air temperature sensor for sensing the temperature of air in the air flow from the fan to the passenger compartment, at least one heat exchange to control the temperature of the air flow from the fan, a control for setting the desired interior temperature and a control unit connected to
10 said sensors, fan, heat exchangers, and temperature control and which is operative to calculate a theoretical interior temperature based on the ambient air temperature, the mixed air temperature, radiation intensity, and air flow from the fan and to compare the calculated theoretical temperature value with the preset temperature value, calculating the
15 difference and control the airflow and mixed temperature accordingly to achieve and maintain the preset interior temperature.

There is also provided a method of environmental control of the interior of a motor vehicle the vehicle having an environmental control apparatus
20 including a fan, a heat exchanger which can vary the temperature of the airflow from the fan, said method comprising:

presetting a desired interior temperature, detecting the exterior ambient temperature of air external of the vehicle, detecting a mixed air temperature of air in the air flow from the fan to the interior of the vehicle,
25 and detecting the volume of air flow from the fan to the interior of the vehicle, characterised in that the method further includes detecting any radiant energy entering the vehicle, and producing a theoretical interior temperature value calculated from ambient air temperature, mixed air temperature, radiant energy intensity, and airflow comparing the
30 theoretical temperature value with the preset temperature value to produce a temperature difference, which is utilised to control air flow, and mixed air temperature, in order to achieve and maintain preset interior temperature.

35 The invention thus only using information from sensors sensing the external heat load on the compartment and the temperature and volume of air supplied to the compartment in order to control the heating of the air

supplied to the compartment.

The invention will be described by way of example and with reference to the accompanying drawings in which:

- 5 Fig.1 shows a schematic layout of an environmental control system according to the present invention for a vehicle interior compartment,
Fig.2 shows a function for calculate a start/previous value for T_I ,
Fig.3 shows a function for controlling blower fan current I_F and mixed air temperature dependent of dT_I .

10 Detailed Description of Invention

With reference to the drawings there is illustrated in schematic form an environmental control system for the interior of a motor vehicle and more specifically an air conditioning and heating system for the passenger compartment of a vehicle.

15

Ducting 10 has an ambient air inlet 11 to receive ambient air A from outside of the vehicle. The ducting 10 also has a second inlet 12 to receive recirculated air R from within the vehicle. The air can be drawn into ducting 10 by a blower fan 13 which is driven by an electric motor.

20

The inducted air is then cooled by an evaporator 14 having a compressor 31, and then the cooled air passes over a heat exchanger 15 which heats a portion of the air flow. The amount of cooled air which is passed over the heat exchanger is controlled by a gate valve 16 operated by a motor 25.

25

The heated air is remixed with the cooled air in a mixing chamber 17 downstream of the gate valve 16 and is discharged into a passenger compartment 19 via air distribution system 18 and outlet ducts 21. The distribution system 18 is controlled by a motor 22 to determine the air distribution within the compartment 19. Air exits the interior of the

30

vehicle through exit ducts 20.
The ratio of recirculated air to fresh air entering the ducting 10 is controlled by a second gate valve 23 operated by a motor 24.

35

The operating conditions within the ducting are monitored by a plurality of sensors. An ambient air temperature sensor 26 is located in the ambient air inlet 11, a mixed air temperature sensor 27 is located in the mixing chamber 17, and a cooled air temperature sensor 28 is located adjacent the

evaporator 14. A solar sensor 29 within the passenger compartment measures the sun's intensity and elevation.

5 The system is controlled by an electronic circuit including micro processors. The control will be explained by means of a block diagram. The ambient/recirculated air for the value 23 is controlled by a recirculation control 41. The fan 13 is controlled by a fan control 42. The evaporator 14 and compressor 28 are controlled by an air conditioning control 43. The gate valve 16 is controlled by a heat control 44. The
10 distribution system is controlled by the distribution control 45. All said controls 41-45 are connected to compartment control 46 including micro processor means.

15 The compartment control 46 is connected a temperature control 47 for presetting a desired interior temperature $T_{I\text{Set}}$, and further includes a compartment temperature calculator 48 to which it is connected. The temperature calculator 48 includes microprocessor means and is connected to the sensors 26, 27, and 29, and to the fan control 42 and air conditioning control 43.

20 The recirculation control 41 operates the motor 24 to move the gate valve 23 depending upon the ambient air temperature, the distribution system setting for distributing air within the compartment 19, and the previous conditions within the system. The control 41 can be manually overrode.

25 The fan control 42 controls the fan motor by controlling the current to the motor and can be manually overrode.

30 The air conditioning control 43 is connected to the cooled air sensor 28 and controls the evaporator 14 dependant upon signals received from the compartment control 46. Again the air conditioning control can be manually overrode.

35 The heat control 44 measures the mixed air temperature via the sensor 27, detects the position of the gate valve 16, and controls the mixed air temperature by controlling the position of the gate valve 16. The gate valve position can vary between fully open and fully closed depending upon the desired temperture of the mixed air.

The distribution control detects and controls the operative condition of the distribution system so the desired outlet ducts 21 are utilised.

5 The compartment temperature calculator 48 measures the ambient air temperature T_A through sensor 26, the mixed air temperature T_M through sensor 27, the solar intensity S_I and solar elevation S_E through the solar sensor 29, the blow fan current I_F and calculates a theoretical interior compartment temperature T_I allowing to the following calculation;

$$10 \quad \frac{dT_I}{dt} = a \cdot I_F \cdot T_M + b \cdot f(T_M, T_A \dots) + c \cdot T_A + E \cdot \cos(S_E) \cdot S_I - e \cdot T_I$$

where :

$$e = a \cdot I_F + b + c$$

15

Temperatures are in C° , Celsius degrees.

$a - c$ are constants,

I_F is blower fan current in ampere (A),

T_A and T_M are as above,

20 T_I is the calculated interior space temperature,

S_E is angle of elevation of the sun (the Zenith = 90°),

S_I is the solar intensity measured in W/m^2 ,

E has in general a cosinus characteristic, but depending on window angel and size,

25 $f(T_M, T_A \dots)$ is a function for calculating a start/previous value for T_I and can for example look like this: $f(T_M, T_A \dots) = Q(T_A) \cdot T_M$. (se also fig.2)

The compartment control 46 compares the calculated temperature T_I value with the preset desired temperature T_{Iset} and calculates a temperature difference ΔT_I . The temperature difference ΔT_I is then used in combination with the measured ambient temperature T_A , mixed air temperature T_M , blower fan current I_F and solar intensity S_I and solar elevation S_E , to calculate new values for the blower current, mixed air temperature, distribution system condition, ambient/recirculated gate valve position. These new values are sent to the respective control units so
35 that they can be executed.

The control of the blower fan current I_F and the mixed air temperature T_M , are controlled by the fan control unit (42) and the heat control unit (44) where dT_I are one of its parameters and can preferably follow the relations depicted in figure 3.

5

Where it is desired to operate the control system to control the environment in a two zoned interior space for example, a left zone and a right zone or front and rear zones, then said equations are:

10 For the right (or front) zone,

$$dT_{Ir} / dt = a \cdot I_{Fr} \cdot T_{Mr} + b \cdot f_1(T_{Mr}, T_A, \dots) + c \cdot T_A + E \cdot \cos(S_E) \cdot S_I \cdot f_2(S_{Ar}) + g \cdot (T_{Il} - T_{Ir}) - e_r \cdot T_{Ir}$$

and for the left (or rear) zone,

15
$$dT_{Il} / dt = a \cdot I_{Fl} \cdot T_{Ml} + b \cdot f(T_{Ml}, T_A, \dots) + c \cdot T_A + E \cdot \cos(S_E) \cdot S_I \cdot f_2(S_{Al}) + g \cdot (T_{Ir} - T_{Il}) - e_l \cdot T_{Il}$$

where

$$e_r = a \cdot I_{Fr} + b + c$$

$$e_l = a \cdot I_{Fl} + b + c$$

20

a - c and g are constants

I_{Fr} is the blowerfan current (airflow) right side in ampere (A),

I_{Fl} is the blowerfan current (airflow) left side in ampere (A),

T_A is the ambient air temperature in degrees C° ,

25 T_{Mr} is the mixed air temperature right side in degrees celsius (C°),

T_{Ml} is the mixed air temperature left side in degrees celsius (C°),

T_{Ir} is the right side calculated interior temperature in degrees C° ,

T_{Il} is the left side calculated interior temperature in degrees C° ,

S_E is the angle of elevation of the sun in degrees (Zenit = 90°),

30 S_I is the solar intensity measured in W/m^2 ,

E has in general a cosinus characteristic, but depending on window angel and size,

$f_1(T_{Mr}, T_A, \dots)$ is a function for calculate a start-/previus value for T_{Ir} ,

$f_2(T_{Ml}, T_A, \dots)$ is a function for calculate a start-/previus value for T_{Il} ,

35 $f_2(S_{Ar})$ is a function for calculate the solarload of the right side,

$f_2(S_{Al})$ is a function for calculate the solarload of the left side.

The inventive apparatus and method is not limited to environmental control of interiors of motor vehicles with environmental control apparatuses entirely lacking the usage of an interior temperature sensor. The control method could preferably also be used together with an interior temperature sensor, and then be used to improve the system performance by achieving an average value between calculated interior space temperature and the interior temperature measured by the interior temperature sensor.

10

15

20

25

30

35

Claims

1. Apparatus for environmental control of interior of a motor vehicle, the apparatus comprising a fan (13) supplying an air flow to the vehicle compartment(19), an ambient air temperature sensor (26) for monitoring ambient air temperature, a radiation detector (29) for measuring the intensity of radiation entering the interior of the vehicle, at least one heat exchange(14,15) to control the temperature of the air flow from the fan (13), a mixed air temperature sensor (27) for sensing the temperature of air in the air flow from the fan (13) to the passenger compartment (19), a control (47) for setting the desired interior temperature and a control unit (46) connected to said sensors (26,27,29), fan (13), heat exchangers (14,15), and temperature control (42-44) and which is operative to calculate a theoretical interior temperature based on the ambient air temperature, the mixed air temperature, radiation intensity, and air flow from the fan and to compare the calculated theoretical temperature value with the preset temperature value, calculating the difference and control the airflow and mixed temperature accordingly to achieve and maintain the preset interior temperature.
2. Apparatus as claimed in Claim 1 wherein the heat exchanger comprises an evaporator(14) for cooling the air, and which is located downstream of the fan (13), and a heater (15) for heating the air and which is located downstream of the evaporator (14), and the control unit further controls a distributor means (16) for determining the percentage of cooled air which passes over the heater (15) in order to achieve the desired mixed air temperature.
3. Apparatus as claimed in Claim 2, characterised in that there is further provided an evaporator temperature sensor (28) which is connected to the control unit (43) of the evaporator (14) and its associated compressor (31) are operated by control unit (46) to produce cooled air to further provide mixed air of a desired temperature.
4. Apparatus as claimed in any one of Claims 1 to 3, characterised in that the radiation detector is a solar sensor (29).

5. Apparatus as claimed in Claim 4, characterised in that the solar sensor (29) measures the solar intensity (S_I), the solar elevation (S_E) and the solar azimuth (S_A).

5 6. A method of environmental control of the interior of a motor vehicle the vehicle having an environmental control apparatus including a fan, a heat exchanger which can vary the temperature of airflow from the fan, said method comprising:

10 presetting a desired interior temperature, detecting the exterior ambient temperature of air external of the vehicle, detecting a mixed air temperature of air in the air flow from the fan to the interior of the vehicle, and detecting the volume of air flow from the fan to the interior of the vehicle, characterised in that the method further includes
15 detecting radiation energy entering the vehicle, and producing a theoretical interior temperature value calculated from ambient air temperature, mixed air temperature, radiation intensity, and airflow
20 comparing the theoretical temperature value with the preset temperature value to produce a temperature difference, which is utilised to control air flow, and mixed air temperature, in order to achieve and maintain preset interior temperature.

7. A control method as claimed in Claim 6, characterised in that the radiation energy is solar energy .

25 8. A control method as claimed in Claim 7, characterised in that the solar energy is measured as a function of solar intensity and solar elevation.

30

35

9. A control method as claimed in Claim 8, wherein the calculated temperature is given by the following equation;

$$5 \quad \frac{dT_I}{dt} = a \cdot I_F \cdot T_M + b \cdot f(T_M, T_A \dots) + c \cdot T_A + E \cdot \cos(S_E) \cdot S_I - e \cdot T_I$$

where :

$$e = a \cdot I_F + b + c$$

10 Temperatures are in C°, Celsius degrees.

a - c are constants,

I_F is blower fan current in ampere (A),

T_A and T_M are as above,

T_I is the calculated interior space temperature,

15 S_E is angle of elevation of the sun (the Zenith = 90°),

S_I is the solar intensity measured in W/m²,

E has in general a cosinus characteristic, but depending on window angel and size,

f(T_M T_A...) is a function for calculating a start/previous value for T_I.

20

25

30

35

10. A control method as claimed in Claim 9 for a two zoned interior space, wherein calculated temperatures for two zones are given by equations :

for one zone,

$$5 \quad dT_{Ir} / dt = a \cdot I_{Fr} \cdot T_{Mr} + b \cdot f_1(T_{Mr}, T_A, \dots) + c \cdot T_A + E \cdot \cos(S_E) \\ \cdot S_I \cdot f_2(S_{Ar}) + g \cdot (T_{II} - T_{Ir}) - e_r \cdot T_{Ir}$$

and for the second zone,

$$dT_{II} / dt = a \cdot I_{FI} \cdot T_{MI} + b \cdot f(T_{MI}, T_A, \dots) + c \cdot T_A + E \cdot \cos(S_E) \\ \cdot S_I \cdot f_2(S_{AI}) + g \cdot (T_{Ir} - T_{II}) - e_l \cdot T_{II}$$

10

where

$$e_r = a \cdot I_{Fr} + b + c$$

$$e_l = a \cdot I_{FI} + b + c$$

15

a-c and g are constants

I_{Fr} is the blowerfan current (airflow) , first zone, in ampere (A),

I_{FI} is the blowerfan current (airflow), second zone, in ampere (A),

T_A is the ambient air temperature in degrees C° ,

T_{Mr} is the mixed air temperature, first zone, in degrees celsius (C°),

20 T_{MI} is the mixed air temperature, second zone, in degrees celsius (C°),

T_{Ir} is the, first zone, calculated interior temperature in degrees C° ,

T_{II} is the, second zone, calculated interior temperature in degrees C° ,

S_E is the angle of elevation of the sun in degrees (Zenit = 90°),

S_I is the solar intensity measured in W/m²,

25

E has in general a cosinus characteristic, but depending on window angel and size,

$f_1(T_{Mr}, T_A, \dots)$ is a function for calculate a start-/previus value for T_{Ir} ,

$f_2(T_{MI}, T_A, \dots)$ is a function for calculate a start-/previus value for T_{II} ,

$f_2(S_{Ar})$ is a function for calculate the solarload of the first zone,

30

$f_2(S_{AI})$ is a function for calculate the solarload of the second zone.

35

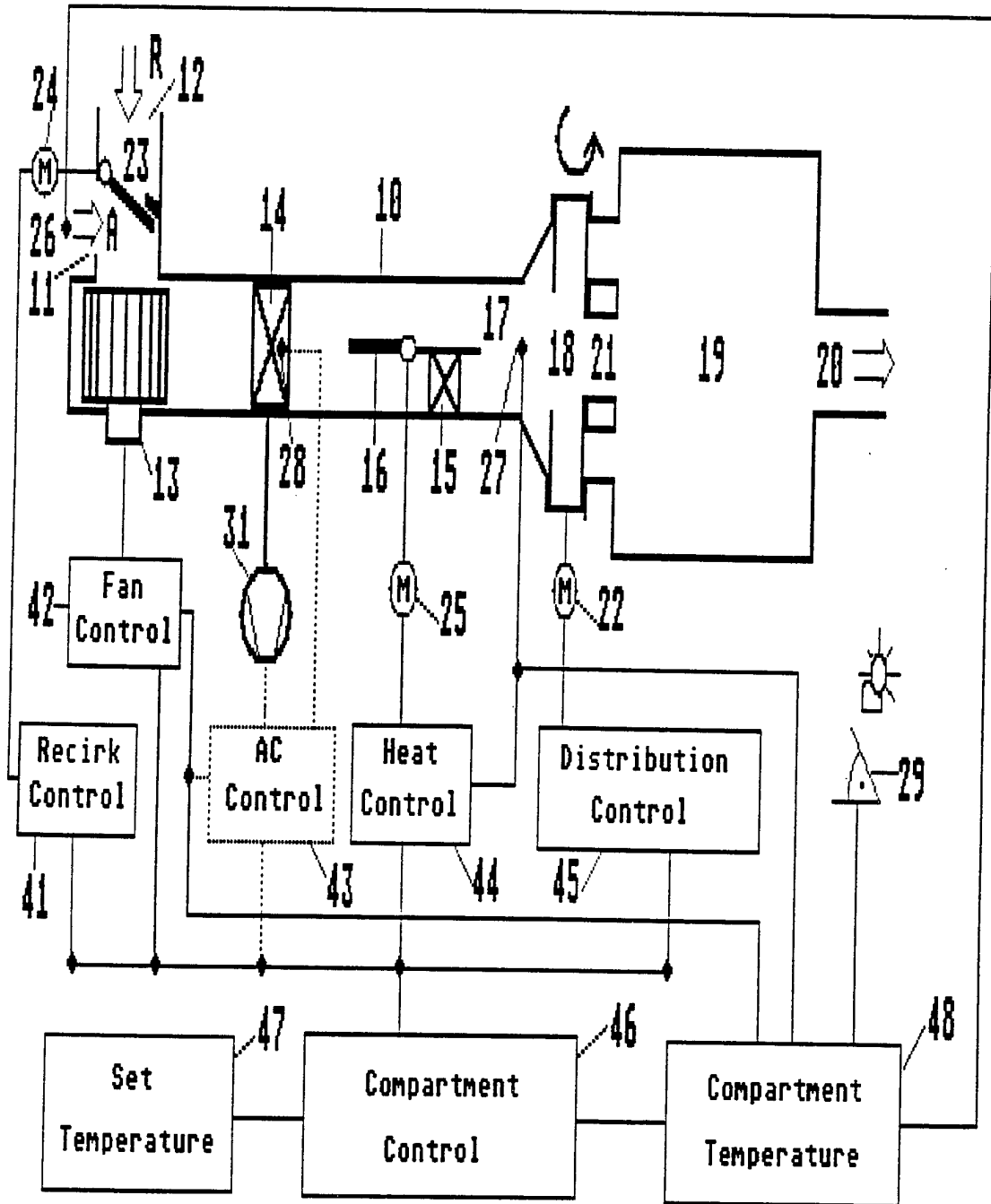

FIG. 1

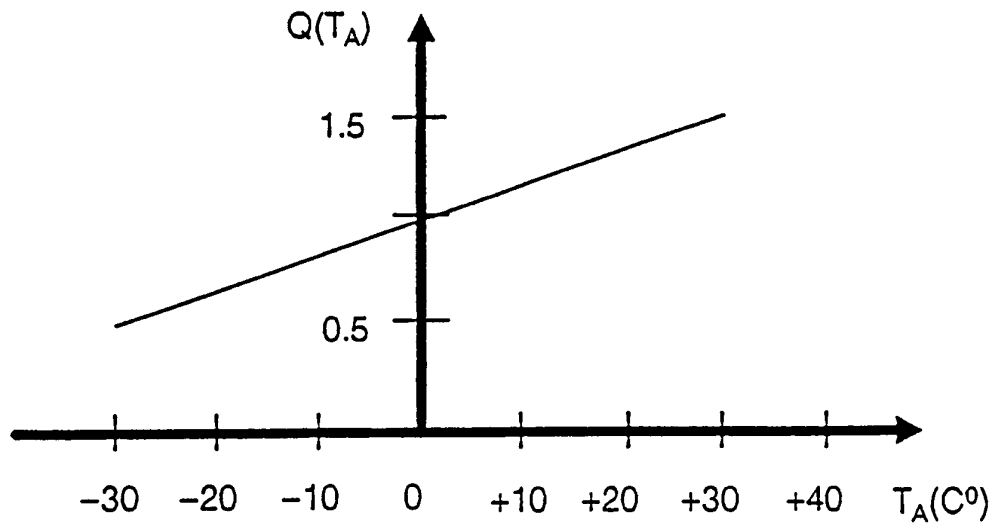

FIG. 2

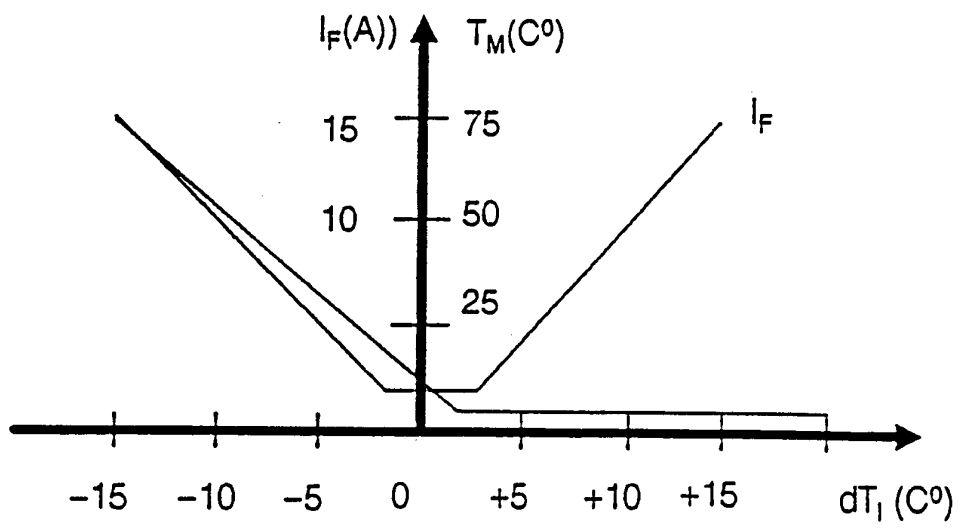

FIG. 3

INTERNATIONAL SEARCH REPORT

International application No.

PCT/SE 93/00103

A. CLASSIFICATION OF SUBJECT MATTER		
IPC5: B60H 1/00, G05D 23/19 According to International Patent Classification (IPC) or to both national classification and IPC		
B. FIELDS SEARCHED		
Minimum documentation searched (classification system followed by classification symbols)		
IPC5: B60H		
Documentation searched other than minimum documentation to the extent that such documents are included in the fields searched		
SE,DK,FI,NO classes as above		
Electronic data base consulted during the international search (name of data base and, where practicable, search terms used)		
DIALOG		
C. DOCUMENTS CONSIDERED TO BE RELEVANT		
Category*	Citation of document, with indication, where appropriate, of the relevant passages	Relevant to claim No.
A	EP, A2, 0381846 (SÜDDEUTSCHE KÜHLERFABRIK JULIUS FR. BEHR GMBH & CO. KG), 16 August 1990 (16.08.90), abstract --	1,6
A	EP, A2, 0492324 (HELLA KG HUECK & CO.), 1 July 1992 (01.07.92), abstract --	1,6
A	US, A, 4757944 (KAGOHATA ET AL.), 19 July 1988 (19.07.88), abstract -- -----	1,6
<input type="checkbox"/> Further documents are listed in the continuation of Box C. <input checked="" type="checkbox"/> See patent family annex.		
* Special categories of cited documents: "A" document defining the general state of the art which is not considered to be of particular relevance "E" earlier document but published on or after the international filing date "L" document which may throw doubts on priority claim(s) or which is cited to establish the publication date of another citation or other special reason (as specified) "O" document referring to an oral disclosure, use, exhibition or other means "P" document published prior to the international filing date but later than the priority date claimed		"T" later document published after the international filing date or priority date and not in conflict with the application but cited to understand the principle or theory underlying the invention "X" document of particular relevance: the claimed invention cannot be considered novel or cannot be considered to involve an inventive step when the document is taken alone "Y" document of particular relevance: the claimed invention cannot be considered to involve an inventive step when the document is combined with one or more other such documents, such combination being obvious to a person skilled in the art "&" document member of the same patent family
Date of the actual completion of the international search		Date of mailing of the international search report
14 Sept 1993		16 -09- 1993
Name and mailing address of the ISA/ Swedish Patent Office Box 5055, S-102 42 STOCKHOLM Facsimile No. +46 8 666 02 86		Authorized officer Björn Salén Telephone No. +46 8 782 25 00

INTERNATIONAL SEARCH REPORT
Information on patent family members

26/08/93

International application No.
PCT/SE 93/00103

Patent document cited in search report	Publication date	Patent family member(s)	Publication date
EP-A2- 0381846	16/08/90	DE-A- 3903462	09/08/90
EP-A2- 0492324	01/07/92	DE-A- 4040846	25/06/92
US-A- 4757944	19/07/88	CA-A- 1266314	27/02/90
		JP-A- 62234712	15/10/87