

(19) World Intellectual Property Organization
International Bureau



(43) International Publication Date
11 October 2001 (11.10.2001)

PCT

(10) International Publication Number
WO 01/75509 A1

- (51) International Patent Classification⁷: G02C 7/04
- (21) International Application Number: PCT/US01/09923
- (22) International Filing Date: 28 March 2001 (28.03.2001)
- (25) Filing Language: English
- (26) Publication Language: English
- (30) Priority Data:
60/193,493 31 March 2000 (31.03.2000) US
09/818,244 27 March 2001 (27.03.2001) US
- (71) Applicant: OCULAR SCIENCES, INC. [US/US]; 475
Eccles Avenue, So. San Francisco, CA 94080 (US).
- (72) Inventor: BACK, Arthur; 24 Oswald Street, Randwick,
NSW 2031 (AU).
- (74) Agents: UXA, Frank, J. et al.; Stout, Uxa, Buyan &
Mullins, LLP, 4 Venture #300, Irvine, CA 92618 (US).
- (81) Designated States (*national*): AE, AG, AL, AM, AT, AU,
AZ, BA, BB, BG, BR, BY, BZ, CA, CH, CN, CO, CR, CU,
CZ, DE, DK, DM, DZ, EE, ES, FI, GB, GD, GE, GH, GM,
HR, HU, ID, IL, IN, IS, JP, KE, KG, KP, KR, KZ, LC, LK,
LR, LS, LT, LU, LV, MA, MD, MG, MK, MN, MW, MX,
MZ, NO, NZ, PL, PT, RO, RU, SD, SE, SG, SI, SK, SL,
TJ, TM, TR, TT, TZ, UA, UG, UZ, VN, YU, ZA, ZW.
- (84) Designated States (*regional*): ARIPO patent (GH, GM,
KE, LS, MW, MZ, SD, SL, SZ, TZ, UG, ZW), Eurasian
patent (AM, AZ, BY, KG, KZ, MD, RU, TJ, TM), European
patent (AT, BE, CH, CY, DE, DK, ES, FI, FR, GB, GR, IE,
IT, LU, MC, NL, PT, SE, TR), OAPI patent (BF, BJ, CF,
CG, CI, CM, GA, GN, GW, ML, MR, NE, SN, TD, TG).

[Continued on next page]

(54) Title: CONTACT LENS HAVING A UNIFORM HORIZONTAL THICKNESS PROFILE

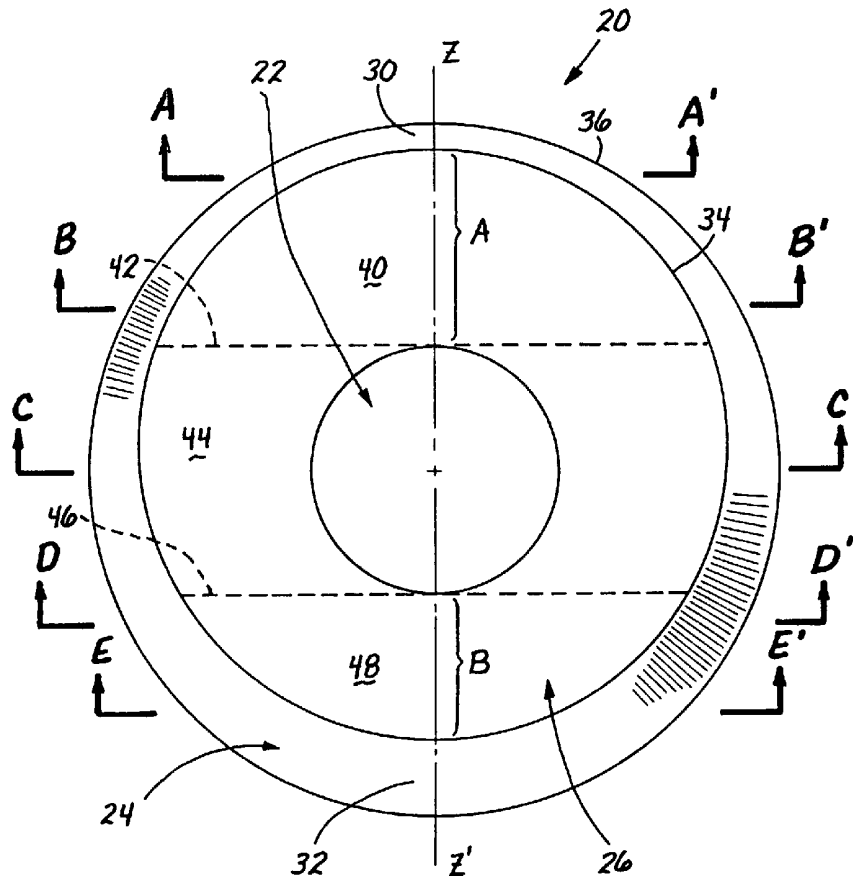

(57) Abstract: A contact lens (20) having a rotational stabilization mechanism thereon, and a thickness profile that reduces the torque imparted on the lens by the action of the eyelids. The prism ballast is provided on one or more portions of the anterior face of the lens such that the lens body has a uniform thickness of within 10% along horizontal cross-section. The anterior face of the lens may be segregated into a peripheral zone (24), an inner zone (26) circumscribed by the peripheral zone (24), and a central optic zone (22). The prism ballast portion is provided within the inner zone (26), which may be further subdivided into a superior portion (40), an intermediate portion (44) proximate the optic zone (22), and an inferior portion (48). The ballast portion increases in thickness along a superior-inferior line parallel to a vertical meridian, and has a substantially uniform thickness perpendicular thereto.



WO 01/75509 A1



Published:

— with international search report

For two-letter codes and other abbreviations, refer to the "Guidance Notes on Codes and Abbreviations" appearing at the beginning of each regular issue of the PCT Gazette.

CONTACT LENS HAVING A UNIFORM HORIZONTAL THICKNESS**PROFILE****Related Application**

This application claims the benefit of priority under 35 U.S.C. §119(e) of U.S. provisional application No. 60/193,493, filed March 31, 2000.

Background of the Invention

The present invention relates to contact lenses and, in particular, to an improved ballast, preferably a prism ballast, for toric lenses that imposes a low-torque rotational correction on the lens.

Astigmatism is a defect in the eye that is corrected by a lens with a non-spherical prescription. The prescription, which is usually expressed as cylinder on the patient's prescription order, causes at least a portion of the surface of the lens to have the shape of the toric segment. A torus is a surface or object defined by the rotation of a circle about an axis other than its own. For example, a donut has a toroidal shape. The toric portion of the lens is a small oval-shaped section of the toroid, with a major axis and a minor axis. As a result of this non-axi-symmetric configuration, proper rotational orientation of the lens must be maintained. It should be noted that other lenses, for instance that provide bifocal or multi-focal correction, are non-axi-symmetric and thus have a particular orientation outside of which performance suffers.

Astigmatism is often associated with other refractive errors such as myopia or hypermetropia, and so toric contact lenses often also provide some spherical correction, negative or positive. While the concave or posterior surface of a contact lens generally has a

spherical configuration, where the lens is used to correct astigmatism the posterior surface will usually have the toric configuration. That is, the curved portion of the posterior surface of the lens has a major axis and a minor axis. The radius of curvature of the posterior surface of the lens is larger in the major-axis direction than in the minor-axis direction. The major diameter of the toric surface is generally smaller in diameter than the overall lens, and is cut into a starting spherical base curve. Additionally, the anterior and/or posterior surface(s) of the optical zone may include a spherical portion that contributes to a distance refractive correction. The spherical correction is typically provided on the exterior or anterior surface. Of course, certain prescriptions provide the toric curve on the anterior surface, with the spherical correction also on the anterior surface, or on the posterior surface.

While spectacle lenses are held rigidly in place by a frame, toric contact lenses must be stabilized so that the cylindrical correction is stabilized in substantially the correct position on the eye. Soft contact lenses which had been designed for use to correct astigmatism are well-known in the art. Generally, these lenses rely on some type of ballasting or stabilizing method to cause the lens to be properly oriented in the eye. The ballast is typically provided on a contact lens by incorporating structures either on the front surface or on the back surface, or spread between both surfaces. Such orientation structures utilize eyelid forces generated during blinking. As the eyelids wipe across the contact lens, they tend to squeeze the lens down and against the cornea and displace elevated surface features.

A so-called "wedge" or "prism" ballast may be utilized wherein the lower or inferior portion of the lens is

relatively thicker than the upper or superior portion. As a result, the upper eyelid, which undergoes greater movement than the lower eyelid, and thus exerts greater influence on the contact lens, tends to displace the inferior portion of the contact lens downward, inherently rotating the contact lens over the cornea into the intended orientation. Alternatively, the lens may incorporate a so-called "periballast" (short for peripheral ballast) stabilization that involves a ballast region surrounding but excluding the central optic.

For examples of prism ballast, see U.S. Patent Nos. 4,573,774, 5,125,728, and 5,020,898, and PCT Publication No. WO 98/45749. Another orientation structure for contact lenses includes the provision of thin superior and inferior zones relative to a thicker central zone. Such structures are shown in U.S. Patent Nos. 4,095,878, and 5,650,837. Alternatively, channels or ridges may be provided on the contact lens, such as seen in PCT publication No. AU 92/00290.

U.S. Patent No. 5,020,898 describes a toric contact lens with ballast distributed outside the anterior optical zone such that the ballast thickens from the top of the lens to two points of maximum thickness proximate the lower peripheral edge.

U.S. Patent No. 5,125,728 also describes a ballast portion that increases from a superior part of the lens to a maximum thickness in the lower periphery on each side thereof. The maximum thickness of the ballast is located as close as possible to the lens edge so that these portions fit over the peripheral cornea and conjunctiva to limit lens rotation. A ballast-free corridor of least resistance is provided in the vertical mid-section of the lens above and below the central optical area. The patent asserts that the ballast-free corridor in combination with

the thicker ballast and thicker portions close to the lens periphery provides an improved stabilization mechanism.

Finally, PCT Publication No. WO 98/45749 describes a ballast lens with a prism through the optical zone. The anterior and posterior optical zone diameters are selected such that when combined to form a lens, the thickness at the superior and inferior junctions of the optical zone on the anterior face is controlled.

In addition to the relative ability of a lens to orient consistently on cornea, other factors affect the performance of the various stabilization structures. For example, some structures are better than others with respect to one or more of the following: reducing the overall thickness across the toric contact lens for the physiological benefit of the wearer, ease of manufacture, reducing the lens parameter inventory, clinical performance including wearer comfort and consistency of fitting between refractive powers. With respect to wearer comfort, in general, the thinner the lens and the smoother the surface, the more comfort will be provided. In addition, it is known to provide a periphery on the lens that is relatively thin and shaped for added comfort.

The principal limitation of existing toric contact lens designs is that orientation is highly variable and/or uncomfortable, for a given design, between individual toric lens wearers. Besides the lens design and lens material, patient factors also influence the orientation of a toric contact lens on the eye and contribute to this variability in lens orientation. Patient factors such as blink characteristics and ocular parameters such as eyelid, corneal, and conjunctival shape and anatomy may result in undesired interaction (for example, asymmetry) or insufficient interaction with the contact lens. However, many of the problems associated with prior art mechanisms

may be attributed to problems with failure of the stabilization mechanism to maximize eyelid interaction and reduce the variability of lens orientation between individuals.

Despite much effort in this area, there is still a need for a toric contact lens that has more consistent stabilization features between individuals.

Summary of the Invention

In accordance with the present invention, a contact lens having improved thickness and ballast arrangement is provided. The contact lens of the present invention reduces the known variability of lens orientation from individual to individual. Further, the lenses of the present invention provide more effective interaction between the stabilization mechanism and the eyelid during blinking, and preferably include a peripheral zone that is required for wearer comfort.

In one aspect, therefore, the present invention provides a contact lens, including a contact lens body having a generally spherical base curvature with a convex anterior face, a concave posterior face, and a peripheral edge therebetween. A peripheral zone is defined adjacent the peripheral edge of the anterior face. The body has a thickness between the anterior face and the posterior face and is non-axi-symmetric so as to define a superior edge and an inferior edge. Further, a vertical meridian is defined from the superior edge toward the inferior edge and a horizontal meridian is defined perpendicular thereto. The anterior face defines a plurality of zones thereon, including an inner zone circumscribed by the peripheral zone, and an optic zone defined generally in the middle of the inner zone. Additionally, the lens includes a prism ballast portion whereby the thickness increases parallel to

the vertical meridian from the superior edge toward the inferior edge in at least a ballast portion of the inner zone. The inner zone comprises a superior portion between the optic zone and the superior extent of the inner zone, an inferior portion between the optic zone and the inferior extent of the inner zone, and an intermediate portion between the superior and inferior portions. The ballast portion is defined within one or more of the superior, intermediate, and inferior portions and has a series of consecutive horizontal cross-sections exclusive of the peripheral zone and optic zone spanning a distance along the vertical meridian of at least 20% of the smallest dimension of the superior, intermediate, and inferior portions as measured along the vertical meridian, wherein each horizontal cross-section has a substantially uniform thickness not varying by more than about 30 μm or 20%, whichever is greater in absolute terms. In one embodiment, the thickness of the contact lens in each of the consecutive horizontal cross-sections does not vary by more than about 15 μm or about 10%, whichever is greater in absolute terms.

In one embodiment, the ballast portion is defined wholly within only one of the superior, intermediate, and inferior portions. In another embodiment, the ballast portion is defined wholly within only two of the superior, intermediate, and inferior portions. In still another embodiment, the ballast portion is defined within all three of the superior, intermediate, and inferior portions, or comprises the entire inner zone.

In a preferred embodiment, a rate of change of thickness in the tapered peripheral zone is less than about 250 $\mu\text{m}/\text{mm}$, more preferably less than about 200 $\mu\text{m}/\text{mm}$.

In an alternative embodiment, a contact lens of the present invention comprises a contact lens body having a

generally spherical base curvature with a convex anterior face, a concave posterior face, and a peripheral edge therebetween. A peripheral zone is defined adjacent the peripheral edge of the lens that tapers thinner toward the peripheral edge of the lens. The lens body has a thickness between the anterior face and the posterior face and is non-axi-symmetric so as to define a superior edge and an inferior edge. A vertical meridian is defined from the superior edge toward the inferior edge and a horizontal meridian is defined perpendicular thereto. The anterior face defines a plurality of zones thereon, including an inner zone circumscribed by the peripheral zone and having a prism ballast portion therein, and an optic zone defined generally in the middle of the inner zone, wherein the thickness increases parallel to the vertical meridian from the superior edge toward the inferior edge in at least the prism ballast portion of the inner zone. Along a 225° meridian, the distance between the inner zone and the peripheral edge is less than about 1.4 mm.

In accordance with one aspect of the invention, a molded contact lens includes a fully molded contact lens body (i.e., molded on both the anterior and posterior faces) having the general features as described above. As before, the molded lens has a prism ballast portion in the inner zone and, along a 225° meridian, the distance between the inner zone and the peripheral edge is less than about 1.8 mm. Alternatively, or desirably in addition, and along a 270° meridian, the distance between the inner zone and the peripheral edge is less than about 2.1 mm, while along a 180° meridian, the distance between the inner zone and the peripheral edge is less than about 1.3 mm.

Desirably, a band circumscribed by the peripheral zone and around the optic zone is substantially annular. Namely, a superior distance A is defined along the vertical

meridian and within the inner zone from the optic zone to the peripheral zone. An inferior distance B is defined along the vertical meridian and within the inner zone from the optic zone to the peripheral zone. For molded prism ballasted lenses the band is annular within the range of $0.33A \leq B \leq A$, while for all prism ballasted lenses the annular band is within the range of $0.55A \leq B \leq A$.

Each and every feature described herein, and each and every combination of two or more of such features, is included within the scope of the present invention provided that the features included in such a combination are not mutually inconsistent.

The invention, together with additional features and advantages thereof, may best be understood by reference to the following description taken in connection with the accompanying illustrative drawings in which like parts bear like reference numerals.

Brief Description of the Drawings

Figure 1 is a schematic front elevational view of a contact lens according to the present invention illustrating various zones defined thereon;

Figure 2 (A-A' to E-E') illustrate a series of horizontal cross-sections taken through the lens of figure 1;

Figure 3 is a graph showing the varying thickness of the contact lens of figure 1 taken along a vertical meridian Z-Z';

Figure 4a is a schematic diagram of the contact lens of the present invention having an exemplary topographical numerical thickness map superimposed thereon;

Figure 4b is a graph of a portion of the contact lens of the present invention illustrating a discontinuity and angular relationship between zones thereon;

Figures 5a-5d are elevational views of contact lenses of the present invention each having a spherical anterior optical zone and varying regions of substantially uniform horizontal thickness;

Figures 6a-6d are elevational views of contact lenses of the present invention each having a toric anterior optical zone and varying regions of substantially uniform horizontal thickness;

Figure 7 is a schematic front elevational view of a contact lens having a number of meridian lines superimposed thereon for reference; and

Figure 8 is a schematic front elevational view of a contact lens of the prior art illustrating various zones defined thereon.

Description of the Preferred Embodiments

The present invention provides stabilized contact lenses, especially contact lenses having a cylindrical correction for astigmatism. More broadly, the present invention provides contact lenses having elevated surfaces thereon that interact with the blinking action of the eyelids to rotationally stabilize the lens. The rotational stability is useful for any contact lens that is non-axi-symmetric. For example, the rotational orientation of toric lenses or multifocal lenses must be maintained for proper correction. It should be understood, however, that rotational stability may also be desirable for other specialized lenses.

In the following description, a number of surfaces and thicknesses of the contact lenses of the present invention will be described with reference to schematic elevational views of the lenses, in that the lenses have been flattened. Contact lenses typically possess an underlying spherical curvature, with the anterior face being convex,

and the posterior face being concave. The various surfaces and optic zones are then either molded or machined from the base sphere. For simplicity, the elevational views shown herein are flattened, with the base sphere removed. In this way, the lines of shading corresponding to the underlying spherical curvature are removed so that the particular surfaces and thicknesses of the present invention can be more clearly illustrated. In a preferred embodiment, lenses of the present invention have a negative spherical power distance correction, and a toric surface for cylindrical correction.

An exemplary contact lens 20 of the present invention is thus shown in schematic elevational view in Figure 1 flattened without shading to illustrate various zones thereon. The lens 20 includes a lens body of suitable soft or rigid material. Soft contact lenses are typically made of a hydrophilic material such as hydroxyethylmethacrylate, metallo-organic substances, silicone rubbers, silicone hydrogels, urethanes, etc. Alternatively, a rigid gas-permeable material such as siloxane acrylate or fluorosiloxane acrylate may be used. The lens body has an overall spherical curvature with a concave posterior face adapted to contact the cornea opposite an outwardly-facing concave anterior face.

With reference to Figure 1, the lens 20 includes an optic zone 22, a peripheral zone 24, and an inner zone 26 circumscribed by the peripheral zone, wherein the optic zone 22 forms a portion of the inner zone 26. Alternatively, the inner zone 26 may be defined between the optic zone and the peripheral zone. As will be described further herein, the optic zone 22 may be circular, toroidal, or other special shapes. The peripheral zone 24 may have a uniform radial dimension (width), or the radial dimension may vary. In the exemplary illustrated

embodiment, the peripheral zone 24 has a narrower radial dimension at a superior end 30, and a wider radial dimension at an inferior end 32. Stated another way, the inner zone 26 has a circular periphery or ballast periphery 34 that is slightly offset toward the top of the lens 20 along a vertical meridian or centerline Z-Z' therethrough. It should be noted that the clear delineations in the drawings between the optic zone 22 peripheral zone 24 and inner zone 26 should not be taken to imply that there is a discontinuity or corner at those locations, and in fact the exemplary lens of the present invention possesses gradually curved transitions between the zones.

A lens edge 36 defines the intersection of the anterior and posterior faces. The peripheral zone 24 desirably exhibits a taper so as to be thinner at the lens edge 36 than at the circular ballast periphery 34. In this regard, the peripheral zone 24 preferably defines a partial conical surface (albeit, superimposed on the underlying spherical curvature). Alternatively, the peripheral zone 24 may define a partial spherical or other curvature (i.e., shape), for example, any suitable curvature.

Various features of the lens 20 are believed to enhance wearer comfort in comparison to other similar lenses. Indeed, certain clinical trials resulted in findings that patients responded more favorably to questions designed to ascertain a comfort level of lenses made according to the present invention than with respect to questions on the comfort level of similar lenses.

The inner zone 26 may be segregated into three parts along the vertical meridian Z-Z'. Specifically, a superior portion 40 extends between the upper extent of the ballast periphery 34 and the upper extent of the optic zone 22, delineated by an imaginary line 42, perpendicular to the vertical meridian Z-Z'. An intermediate portion 44 extends

between the perpendicular line 42 and a second perpendicular line 46 at the lower extent of the optic zone 22. Finally, an inferior portion 48 extends between the perpendicular line 46 and the lower extent of the ballast periphery 34. The optic zone 22 thus lies entirely within the intermediate portion 44.

The superior portion 40, intermediate portion 44, and inferior portion 48 are used in the present application to segregate the inner zone 26 into discrete areas in which specific ballast surfaces can be provided. It should be understood, however, that the dividing lines 42, 46 between the areas may be shifted, or may be non-linear, for that matter. In one aspect, the present invention concerns particular ballast or prism ballast surfaces/thicknesses in one or more portions of the inner zone 26, which portions may be defined in a number of ways. Therefore, the reader will understand that the portions 40, 44, and 48 are shown as exemplary only. Desirably, iso-thickness ballast surfaces are formed in at least 20% (measured as a percent of the vertical dimension), preferably at least 50%, and more preferably at least 100%, of at least one of the portions 40, 44, and 48. More specifically, an iso-thickness prism ballast portion is defined within one or more of the superior, intermediate, and inferior portions 40, 44, and 48 as a series of consecutive horizontal cross-sections exclusive of the peripheral zone and optic zone spanning a distance along the vertical meridian of at least 20% of the smallest dimension of the superior, intermediate, and inferior portions as measured along the vertical meridian. The term "iso-thickness" means that each of the consecutive horizontal cross-sections has a substantially uniform thickness not varying by more than about 30 μm or 20%, whichever is greater in absolute terms. In a particularly preferred construction, ballast surfaces

are provided in at least two, more preferably all three of the portions 40, 44, and 48.

The present invention pertains to contact lenses having rotational stabilization mechanisms thereon, including those with ballasts, e.g., prism ballasts, periballasts, and so-called "dynamically stabilized" lenses. A ballasted lens provides some raised surface contour over which the eyelid wipes to re-orient the lens, generally about its optical axis. A prism ballast provides a wedge or tapered ballast for interaction with the eyelids even in the optic, while a periballast is exclusive of the optic. Dynamic stabilization involves superior and inferior flats on the lens leaving a thickened midsection to interact with the eye, as seen in U.S. Patent No. 4,095,878. Those of skill in the art will also recognize that there may be other such stabilization mechanisms with which the present invention could be advantageously used.

Figure 1 also illustrates a number of representative cross-sectional lines A-A', B-B', C-C', D-D', and E-E' extending perpendicularly with respect to the vertical meridian Z-Z' (i.e., horizontally). These sections are illustrated in Figure 2, with the base spherical curvature shown. The present invention provides that consecutive horizontal cross-sections shown in Figure 2 that possess ballast each has a substantially uniform or iso-thickness, except in the optic zone 22 and peripheral zone 24. For example, one of the cross-sections in Figure 2 having ballast, such as D-D', has a substantially uniform thickness. Alternatively, all of the cross sections shown in Figure 2 that possess ballast may have a uniform thickness except in the optic zone 22 and peripheral zone 24.

Desirably, the sections of substantially uniform thickness do not vary in thickness within one section by

more than about 30 μm or about 20% whichever is greater in absolute terms. In one embodiment, the thickness of the sections varies by no more than about 15 μm or about 10%, such as by no more than about 10 μm or about 7%, whichever is greater. Such variations will be understood to be sufficiently small that the sections can still be regarded as being of "substantially uniform" thickness.

In an exemplary embodiment of the present invention, the contact lens 20 has a so-called prism ballast superimposed thereon within the entire inner zone 26. That is, from the intersection of the ballast periphery 34 with the vertical meridian Z-Z' at the top of the lens 20, to the intersection between the same two lines at the bottom of the lens, the thickness generally increases. This thickness distribution along the vertical meridian Z-Z' is graphically illustrated in Figure 3, with the superior end 30 of the peripheral zone 24 shown at the right and the inferior end 32 shown at the left. Starting at the right side, the taper of the peripheral zone 24 within the superior end 30 from the edge 36 to the upper extent of the ballast periphery 34 is seen. In the superior portion 40, the thickness gradually increases to the horizontal line 42. The thickness further increases through the optic zone 22 to the horizontal line 46. The greatest thickness is in the inferior portion 48 to the lower extent of the ballast periphery 34. The lens again tapers downward within the peripheral zone 24 between the ballast periphery 34 to the inferior edge 36.

The thickness distribution represented in Figure 3 thus corresponds to a prism ballast within the lens 20 that extends through all of the superior portion 40, intermediate portion 44, and inferior portion 48. Indeed, even the optic zone 22 exhibits this prism ballast. Importantly, the present invention provides a prism ballast

in at least one of these portions 40, 44, 48 having horizontal cross-sections of uniform thickness. Therefore, as seen in Figure 2, all of the cross-sections illustrated have uniform thicknesses along their widths, except in the peripheral zone 24. Of course, because of the increasing thickness in the superior-inferior direction parallel to the vertical meridian Z-Z', the thickness of each cross-section increases from cross-section A-A' to cross-section E-E'.

The uniform thickness in the horizontal cross-sections helps to stabilize lenses of the present invention, in contrast to previous lenses. More specifically, lenses of the present invention are suitable for a greater number of wearers than those of the prior art because of the lower torque exerted by the eyelids on the lens by virtue of the uniform thickness or iso-thickness configuration. The iso-thickness ballast arrangement maximizes eyelid interaction by achieving an even contact across each section of the lens as the eyelid travels down and up the lens during blinking. In contrast, the eyelid generates more rotational torque during a normal blink when interacting with horizontal lens sections of non-uniform thickness, as in the prior art. This is because for a lens to orient appropriately on the eye the lens-eyelid interaction should be maximized across the lens (i.e., across each horizontal cross-section) so that the lens is squeezed into the desired orientation (overall orientation) and undergoes minimal fluctuation during blinking (interblink orientation).

Prior art lenses, having narrow peaks or points of maximum thickness on either side of the vertical meridian are more likely to create a non-uniform lens-eyelid interaction across horizontal sections. In addition, the horizontal distance between peaks of maximum thickness in

the prior art lenses typically increases from a superior portion to the horizontal midline, and then decreases from the mid-line to the inferior portion. This further varies the lens-eyelid interaction forces.

The uniform thicknesses in the horizontal cross-sections of the lens 20 have proven to enhance performance of the lenses in comparison to other similar lenses in terms of maintaining a correct rotational orientation in the eye. Clinical trials have shown that there is less variability in the position of a location mark on the lens over time. For example, groups of 20 people at a time were studied to determine the positions of location marks over time on various lenses in the eye, and the standard deviations of the positions of the location marks were determined. The results are that the standard deviation for lenses of the present invention are measurably smaller than in other lenses, meaning the present lenses had less rotational instability in the eye.

Exemplary values for the thickness of the contact lens 20 having the distribution as seen in Figure 3 are provided in the topographical depiction of Figure 4a. It is understood that the contact lens 20 shown in Figure 4a is generally circular. In Figure 4a, the inner zone 26 is divided by horizontal and vertical grid lines into a plurality of discrete units. Each horizontal row of units has a uniform thickness throughout the inner zone 26. On the other hand, the thickness along a vertical column of units generally increases from the superior to the inferior. For example, horizontal row 50 has a uniform thickness of 140 μm other than in the optic zone. Vertical column 52 has a thickness of 70 μm at the top, gradually increases to 280 μm , and begins to decrease just prior to the inferior portion of the peripheral zone 24. The values provided in Figure 4a are exemplary and are suitable for a

soft hydrogel contact lens. The values for lenses made of other materials may vary depending on the optical or other properties of the particular material.

It will be understood by the reader that the discrete units mapped in Figure 4a represent the average thickness within each unit. That is, the thickness down the lens 20 changes gradually, rather than at a stepped border between units. More generally, although the present application describes distinct zones or portions in contact lenses, those zones are shown for clarity of description of the invention only. It will be appreciated by those skilled in the art that there are no sharp distinctions between these different zones of the lens, but that they are instead smoothly blended into one another.

Figure 4a also illustrates the decreasing thickness or taper of the lens 20 through the peripheral zone 24. For example, at the inferior midpoint, the thickness decreases from 210-140-70 μm . This is also seen in the graph of Figure 3. This taper within the peripheral zone 24 provides a so-called comfort zone around the edge of the lens 20. Because of the reduced thickness, movement of the eyelids across the contact lens is facilitated, and there is less irritation. Specifically, the eyelids more easily travel over the tapered peripheral zone 24 than if there were a more abrupt thickness change.

In an exemplary embodiment, the lens 20 has a corneal fitting relationship to maintain the lens centered on the cornea. The preferred lens has a diameter sufficient to achieve corneal coverage, and optimum stability is provided so that the lens does not become loose and unstable with gaze and blinking, which may influence the comfort and vision of the wearer. The sagittal depth (concave depth of the posterior face) for an optimum lens-cornea fitting relationship is between about 3.0 and 5.0 mm over a lens

diameter of between about 13.0 mm and 16.0 mm. The lens diameter is more preferably between about 13.5-14.8 mm. A preferred thickness of the lens edge 36 is less than about 120 μm , more preferably about 90 μm . In this respect, the thickness is measured radially with respect to the curvature of the anterior face. The extreme outermost extent of the edge 36 may incorporate a preferred rounding of the anterior edge corner.

A plurality of meridian lines may be defined through the center of the lens. In a preferred embodiment, for maximum wearer comfort, the rate of change in lens radial thickness from the end of the ballast zone 34 to the lens edge 36 (i.e., in the peripheral zone 24) is less than about 250 $\mu\text{m}/\text{mm}$ along any meridian of the lens. For example, in the topographical map of Figure 4a, the rate of change of thickness along any meridian and within the peripheral zone 24 is less than about 250 $\mu\text{m}/\text{mm}$. More preferably, the rate of change in the peripheral zone 24 is less than about 200 $\mu\text{m}/\text{mm}$.

The advantageous interaction between the peripheral zone 24 and the iso-thickness is further exemplified in the proximity to the lens edge 36 of the point of maximum thickness, as variously measured around the lens. To illustrate this principle, Figure 7 shows various meridians through the optical axis and around the lens in degrees, starting at the 3:00 o'clock position and moving counterclockwise. Of course, with iso-thickness in the inner zone 26, the point of maximum thickness along any horizontal meridian corresponds to the thickness along the entire horizontal meridian excluding the optical zone. Therefore, the beginning of the inner zone 26 and the point of maximum thickness along any meridian always lies on the ballast periphery 34. However, because of the preferred ballasting, the maximum thickness changes around the

ballast periphery 34.

For prism ballasted lenses in accordance with the present invention, and along the 225° meridian, the distance between the point of maximum thickness (e.g., the ballast periphery 34) and the lens edge 36 is no greater than about 1.4 mm, regardless of the thickness. For any type of ballasted lens, the maximum thickness along the 225° meridian in accordance with the present invention is between about 200-4000 μm , preferably between about 250-350 μm , and more preferably about 320 μm . Along the 270° meridian, the distance between the point of maximum thickness (e.g., the ballast periphery 34) and the lens edge 36 is no greater than 1.8 mm, also regardless of the thickness, though a thickness of about 320 μm is preferred. For fully molded prism ballasted lenses (i.e., molded on both the anterior and posterior faces), and along a 225° meridian, the distance between the between the point of maximum thickness (e.g., the ballast periphery 34) and the peripheral edge is less than about 1.8 mm, and desirably, along a 270° meridian, the distance between the point of maximum thickness and the peripheral edge is less than about 2.1 mm. Also, along a 180° meridian, the distance between the inner zone and the peripheral edge is less than about 1.3 mm. In general, the peripheral zone 24 of the lenses of the present invention are relatively narrow in comparison to the prior art ballasted lenses, yet because of the preferred thicknesses the comfort taper angle in the peripheral zone 24 is relatively shallow, as mentioned above.

Although the preferred lens of the present invention has smooth, rounded transitions between different portions thereon, discrete boundaries or corners are not excluded. For example, the transition between the peripheral zone 24 and the inner zone 26 may be defined by a rounded corner or

discontinuity at the circular ballast periphery 34. An example of the transition between the ballast area 26 and the peripheral zone 24 (i.e., at 34) along the meridian Z-Z' is seen in Figure 3.

Figures 5a-5d illustrate several variations of the contact lens of the present invention having different ballast portions defined within the ballast zone. For purpose of explanation, the reader will refer back to Figure 1 for the definition of the various portions (i.e., superior, intermediate, and inferior) of the inner zone 26. Figure 5a shows a contact lens 70 having a ballast portion 72 defined within the superior portion of the inner zone. Again, the inner zone lies between an optic zone 74 and a peripheral zone 76. Figure 5b illustrates a contact lens 80 of the present invention having a ballast portion 82 defined within both the superior and intermediate portions of the inner zone. Figure 5c shows a contact lens 90 having a ballast portion 92 defined within the entire inner zone, through the superior, intermediate, and inferior portions thereof. Finally, Figure 5d illustrate a contact lens 100 having a ballast portion 102 defined only within the inferior portion of the inner zone.

Other variations not shown include a ballast portion defined wholly within either the intermediate or inferior portions of the inner zone, or within the intermediate and inferior portions combined, exclusive of the superior portion. Also, the ballast portion could surround the optic zone in a so-called "periballast" arrangement, or could continue through the optic zone in a so-called "prism ballast" arrangement.

Figures 6a-6d illustrate a number of other contact lenses of the present invention having a cylindrical correction on the anterior face thereof. More specifically, a toric optic zone 110 is shown in each of

the lenses oriented along a major axis 112 that is rotated with respect to the superior-inferior axis of the lens. The need for proper ballasting for the lenses is thus apparent to maintain the proper offset orientation of the axis 112.

Figure 6a shows a contact lens 120 having a ballast portion 122 beginning in the superior portion and continuing through both the intermediate and inferior portions of the inner zone. Figure 6b shows a contact lens 130 having a ballast portion 132 located entirely within the inferior portion of the inner zone. Figure 6c depicts a contact lens 140 having a ballast portion 142 wholly within the intermediate portion of the inner zone. Finally, Figure 6d shows a lens 150 having a ballast portion 152 only within the superior portion of the inner zone.

Figure 8 shows a prism ballast lens of the prior art (CooperVision Frequency Xcel (Encore) Toric) with lines demarking the transitions between various zones drawn. Specifically, an optic zone 200 is separated from a ballast zone 202 by a generally circular inner line 204, and the ballast zone is separated from a peripheral zone 206 by a generally circular outer line 208. While the inner line 204 is approximately centered as expected on the optical axis OA, the outer line 208 is offset upward along the vertical meridian 210. As a result, the ballast zone 202 is wider in the superior region than the inferior. Specifically, the superior radial width A of the ballast zone 202 is significantly greater than the inferior radial width B. Indeed, the superior radial width A is more than twice the inferior radial width B.

In contrast, as seen in Figure 1, the lenses of the present invention have an inner zone 26 that is substantially annular, with a radial dimension A that is

within about 300% of the radial width B. That is, for molded prism ballasted lenses the band is annular and the relationship $0.33A \leq B \leq A$ holds. Alternatively, for all prism ballasted lenses the annular band is within the range of $0.55A \leq B \leq A$.

It will be appreciated that the present invention may be embodied in lenses having varying optical powers. For example, a contact lens of present invention may have an optic power of about between about -8 to about +8 diopters, although this range is not to be considered limiting.

Additionally, the contact lenses according to the present invention may also comprise stabilization features other than the uniform thickness ballast arrangement. For example, the peripheral zone may include a flattened region for dynamic stabilization, or the lens may incorporate a periballast stabilization outside of the central optic.

While this invention has been described with respect to various specific examples and embodiments, it is to be understood that the invention is not limited thereto and that it can be variously practiced within the scope of the following claims.

WHAT IS CLAIMED IS:

1. A contact lens, comprising:

a contact lens body having a generally spherical base curvature with a convex anterior face, a concave posterior face, and a peripheral edge therebetween with a peripheral zone being defined adjacent the peripheral edge of the anterior face that is tapered thinner toward the peripheral edge of the lens, the body having a thickness between the anterior face and the posterior face and being non-axisymmetric so as to define a superior edge and an inferior edge, with a vertical meridian being defined from the superior edge toward the inferior edge and a horizontal meridian being defined perpendicular thereto;

a plurality of zones on the anterior face, including an inner zone circumscribed by the peripheral zone, and an optic zone defined generally in the middle of the inner zone, wherein the inner zone includes a ballast portion and the thickness increases parallel to the vertical meridian from the superior edge toward the inferior edge in at least the ballast portion of the inner zone;

wherein the inner zone comprises a superior portion between the optic zone and the superior extent of the inner zone, an inferior portion between the optic zone and the inferior extent of the inner zone, and an intermediate portion between the superior and inferior portions; and

the ballast portion is defined within one or more of the superior, intermediate, and inferior portions and has a series of consecutive horizontal cross-sections exclusive of the peripheral zone and optic zone spanning a distance along the vertical meridian of at least 20% of the smallest dimension of the superior, intermediate, and inferior portions as measured along the vertical meridian, wherein each horizontal cross-section has a substantially uniform thickness not varying by more than about 30 μm or 20%,

whichever is greater in absolute terms.

2. The contact lens of claim 1, wherein the thickness of the at least one horizontal cross-section does not vary by more than about 15 μm or 10%, whichever is greater in absolute terms.

3. The contact lens of claim 1, wherein, along a 225° meridian, the distance between the inner zone and the peripheral edge is less than about 1.45 mm.

4. The contact lens of claim 1, wherein, along a 225° meridian, a rate of change of thickness in the tapered peripheral zone is less than about 250 $\mu\text{m}/\text{mm}$.

5. The contact lens of claim 1, wherein the ballast portion is a prism ballast.

6. The contact lens of claim 1, wherein the ballast portion spans a distance along the vertical meridian of at least 50% of the smallest dimension of the superior, intermediate, and inferior portions as measured along the vertical meridian.

7. The contact lens of claim 1, wherein the ballast portion is defined wholly within only one of the superior, intermediate, and inferior portions.

8. The contact lens of claim 1, wherein the ballast portion is defined wholly within only two of the superior, intermediate, and inferior portions.

9. The contact lens of claim 1, wherein the ballast portion is defined within all three of the superior,

intermediate, and inferior portions.

10. The contact lens of claim 1, wherein the ballast portion spans a distance along the vertical meridian of at least 50% of the respective dimensions of the superior, intermediate, and inferior portions as measured along the vertical meridian.

11. The contact lens of claim 10, wherein the ballast portion spans a distance along the vertical meridian of at least 100% of the respective dimensions of the superior, intermediate, and inferior portions as measured along the vertical meridian.

12. The contact lens of claim 11, wherein the ballast portion is provided on the entire inner zone including the optic zone.

13. The contact lens of claim 11, wherein the ballast portion is provided on the entire inner zone except for the optic zone.

14. The contact lens of claim 1, further including a cylindrical correction on either the anterior face or the posterior face.

15. The contact lens of claim 14, wherein the cylindrical correction is provided on the posterior face, and wherein the optic zone of the anterior face comprises a spherical correction.

16. The contact lens of claim 1, wherein the inner zone is of substantially uniform radial width around the circumference of the lens.

17. The contact lens of claim 16, wherein a band circumscribed by the peripheral zone and around the optic zone is substantially annular, with a superior distance A being defined along the vertical meridian and within the inner zone from the optic zone to the peripheral zone, and an inferior distance B being defined along the vertical meridian and within the inner zone from the optic zone to the peripheral zone, and wherein $0.25A \leq B \leq A$.

18. The contact lens of claim 1, wherein the body is a soft contact lens.

19. The contact lens of claim 1, wherein the ballast portion is a periballast.

20. The contact lens of claim 1, wherein the lens further incorporates a dynamic stabilization mechanism.

21. The contact lens of claim 1, wherein the lens further incorporates a negative spherical power distance correction.

22. A contact lens, comprising:

a contact lens body having a generally spherical base curvature with a convex anterior face, a concave posterior face, and a peripheral edge therebetween with a peripheral zone being defined adjacent the peripheral edge of the lens that tapers thinner toward the peripheral edge of the lens, the body having a thickness between the anterior face and the posterior face and being non-axi-symmetric so as to define a superior edge and an inferior edge, with a vertical meridian being defined from the superior edge toward the inferior edge and a horizontal meridian being defined perpendicular thereto;

wherein the anterior face defines a plurality of zones thereon, including an inner zone circumscribed by the peripheral zone and having a prism ballast portion therein, and an optic zone defined generally in the middle of the inner zone, wherein the thickness increases parallel to the vertical meridian from the superior edge toward the inferior edge in at least the prism ballast portion of the inner zone; and

wherein, along a 225° meridian, the distance between the inner zone and the peripheral edge is less than about 1.4 mm.

23. The contact lens of claim 22, wherein, along the 225° meridian, a rate of change of thickness in the tapered peripheral zone is less than about 250 $\mu\text{m}/\text{mm}$.

24. The contact lens of claim 23, wherein, along the 225° meridian, a rate of change of thickness in the tapered peripheral zone is less than about 200 $\mu\text{m}/\text{mm}$.

25. The contact lens of claim 22, wherein the maximum thickness along a 225° meridian of the lens is between about 200-400 μm .

26. The contact lens of claim 25, wherein the maximum thickness along the 225° meridian is between about 250-350 μm .

27. The contact lens of claim 22, wherein the inner zone comprises a superior portion between the optic zone and the superior extent of the inner zone, an inferior portion between the optic zone and the inferior extent of the inner zone, and an intermediate portion between the superior and inferior portions, and wherein the prism

ballast portion is defined within one or more of the superior, intermediate, and inferior portions and has a series of consecutive horizontal cross-sections exclusive of the peripheral zone and optic zone spanning a distance along the vertical meridian of at least 20% of the smallest dimension of the superior, intermediate, and inferior portions as measured along the vertical meridian, wherein each horizontal cross-section has a substantially uniform thickness not varying by more than about 30 μm or 20%, whichever is greater in absolute terms.

28. The contact lens of claim 22, wherein, along a 270° meridian, the distance between the inner zone and the peripheral edge is less than about 1.8 mm.

29. A molded contact lens, comprising:

a fully molded contact lens body having a generally spherical base curvature with a convex anterior face, a concave posterior face, and a peripheral edge therebetween with a peripheral zone being defined adjacent the peripheral edge of the lens that tapers thinner toward the peripheral edge of the lens, the body having a thickness between the anterior face and the posterior face and being non-axi-symmetric so as to define a superior edge and an inferior edge, with a vertical meridian being defined from the superior edge toward the inferior edge and a horizontal meridian being defined perpendicular thereto;

wherein the anterior face defines a plurality of zones thereon, including an inner zone circumscribed by the peripheral zone and having a prism ballast portion therein, and an optic zone defined generally in the middle of the inner zone, wherein the thickness increases parallel to the vertical meridian from the superior edge toward the inferior edge in at least the prism ballast portion of the

inner zone; and

wherein, along a 225° meridian, the distance between the inner zone and the peripheral edge is less than about 1.8 mm.

30. The contact lens of claim 29, wherein the maximum thickness along the 225° meridian is between about 200-400 μm .

31. The contact lens of claim 29, wherein the inner zone comprises a superior portion between the optic zone and the superior extent of the inner zone, an inferior portion between the optic zone and the inferior extent of the inner zone, and an intermediate portion between the superior and inferior portions, and wherein the prism ballast portion is defined within one or more of the superior, intermediate, and inferior portions and has a series of consecutive horizontal cross-sections exclusive of the peripheral zone and optic zone spanning a distance along the vertical meridian of at least 20% of the smallest dimension of the superior, intermediate, and inferior portions as measured along the vertical meridian, wherein each horizontal cross-section has a substantially uniform thickness not varying by more than about 30 μm or 20%, whichever is greater in absolute terms.

32. The contact lens of claim 29, wherein, along a 270° meridian, the distance between the inner zone and the peripheral edge is less than about 2.1 mm.

33. The contact lens of claim 29, along a 180° meridian, the distance between the inner zone and the peripheral edge is less than about 1.3 mm.

34. A molded contact lens, comprising:

a fully molded contact lens body having a generally spherical base curvature with a convex anterior face, a concave posterior face, and a peripheral edge therebetween with a peripheral zone being defined adjacent the peripheral edge of the lens that tapers thinner toward the peripheral edge of the lens, the body having a thickness between the anterior face and the posterior face and being non-axi-symmetric so as to define a superior edge and an inferior edge, with a vertical meridian being defined from the superior edge toward the inferior edge and a horizontal meridian being defined perpendicular thereto;

wherein the anterior face defines a plurality of zones thereon, including an inner zone circumscribed by the peripheral zone and having a prism ballast portion therein, and an optic zone defined generally in the middle of the inner zone, wherein the thickness increases parallel to the vertical meridian from the superior edge toward the inferior edge in at least the prism ballast portion of the inner zone; and

wherein, along a 180° meridian, the distance between the inner zone and the peripheral edge is less than about 1.3 mm.

35. The contact lens of claim 34, wherein, along a 270° meridian, the distance between the inner zone and the peripheral edge is less than about 2.1 mm.

36. The contact lens of claim 34, wherein the inner zone comprises a superior portion between the optic zone and the superior extent of the inner zone, an inferior portion between the optic zone and the inferior extent of the inner zone, and an intermediate portion between the superior and inferior portions, and wherein the prism

ballast portion is defined within one or more of the superior, intermediate, and inferior portions and has a series of consecutive horizontal cross-sections exclusive of the peripheral zone and optic zone spanning a distance along the vertical meridian of at least 20% of the smallest dimension of the superior, intermediate, and inferior portions as measured along the vertical meridian, wherein each horizontal cross-section has a substantially uniform thickness not varying by more than about 30 μm or 20%, whichever is greater in absolute terms.

37. A contact lens, comprising:

a contact lens body having a generally spherical base curvature with a convex anterior face, a concave posterior face, and a peripheral edge therebetween with a peripheral zone being defined adjacent the peripheral edge of the lens that tapers thinner toward the peripheral edge of the lens, the body having a thickness between the anterior face and the posterior face and being non-axi-symmetric so as to define a superior edge and an inferior edge, with a vertical meridian being defined from the superior edge toward the inferior edge and a horizontal meridian being defined perpendicular thereto;

wherein the anterior face defines a plurality of zones thereon, including an inner zone circumscribed by the peripheral zone and having a ballast portion therein, and an optic zone defined generally in the middle of the inner zone, wherein the thickness increases parallel to the vertical meridian from the superior edge toward the inferior edge in at least the ballast portion of the inner zone; and

wherein a band circumscribed by the peripheral zone and around the optic zone is substantially annular, with a superior distance A being defined along the vertical

meridian and within the inner zone from the optic zone to the peripheral zone, and an inferior distance B being defined along the vertical meridian and within the inner zone from the optic zone to the peripheral zone, and wherein $0.55A \leq B \leq A$.

38. A molded contact lens, comprising:

a contact lens body having a generally spherical base curvature with a convex anterior face, a concave posterior face, and a peripheral edge therebetween with a peripheral zone being defined adjacent the peripheral edge of the lens that tapers thinner toward the peripheral edge of the lens, the body having a thickness between the anterior face and the posterior face and being non-axi-symmetric so as to define a superior edge and an inferior edge, with a vertical meridian being defined from the superior edge toward the inferior edge and a horizontal meridian being defined perpendicular thereto;

wherein the anterior face defines a plurality of zones thereon, including an inner zone circumscribed by the peripheral zone and having a molded prism ballast portion therein, and an optic zone defined generally in the middle of the inner zone, wherein the thickness increases parallel to the vertical meridian from the superior edge toward the inferior edge in at least the ballast portion of the inner zone; and

wherein a band circumscribed by the peripheral zone and around the optic zone is substantially annular, with a superior distance A being defined along the vertical meridian and within the inner zone from the optic zone to the peripheral zone, and an inferior distance B being defined along the vertical meridian and within the inner zone from the optic zone to the peripheral zone, and wherein $0.33A \leq B \leq A$.

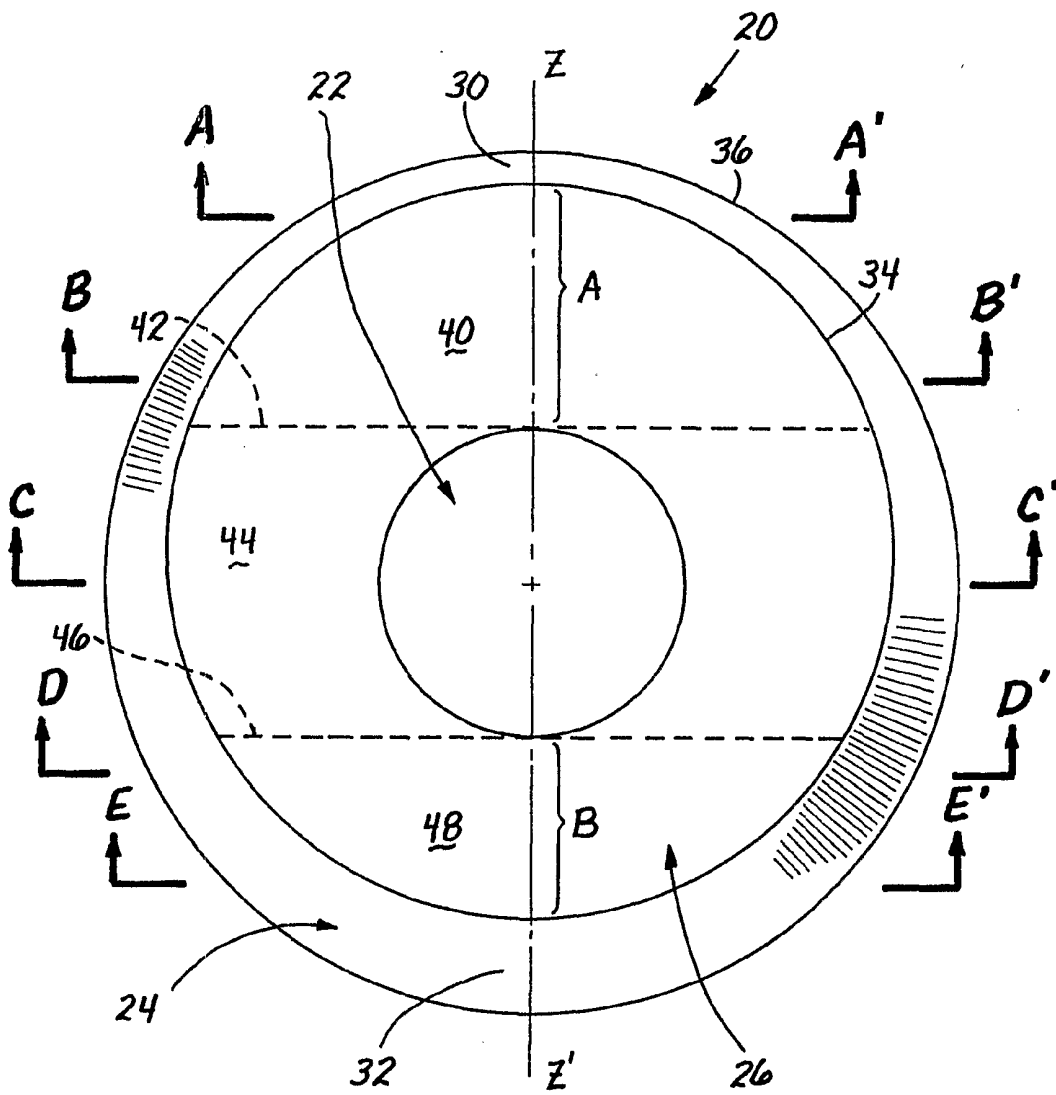

Fig. 1

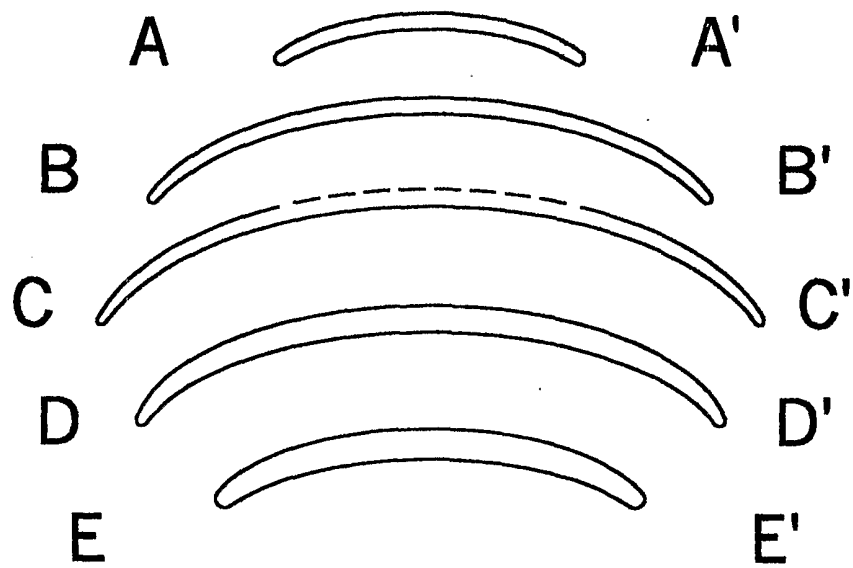
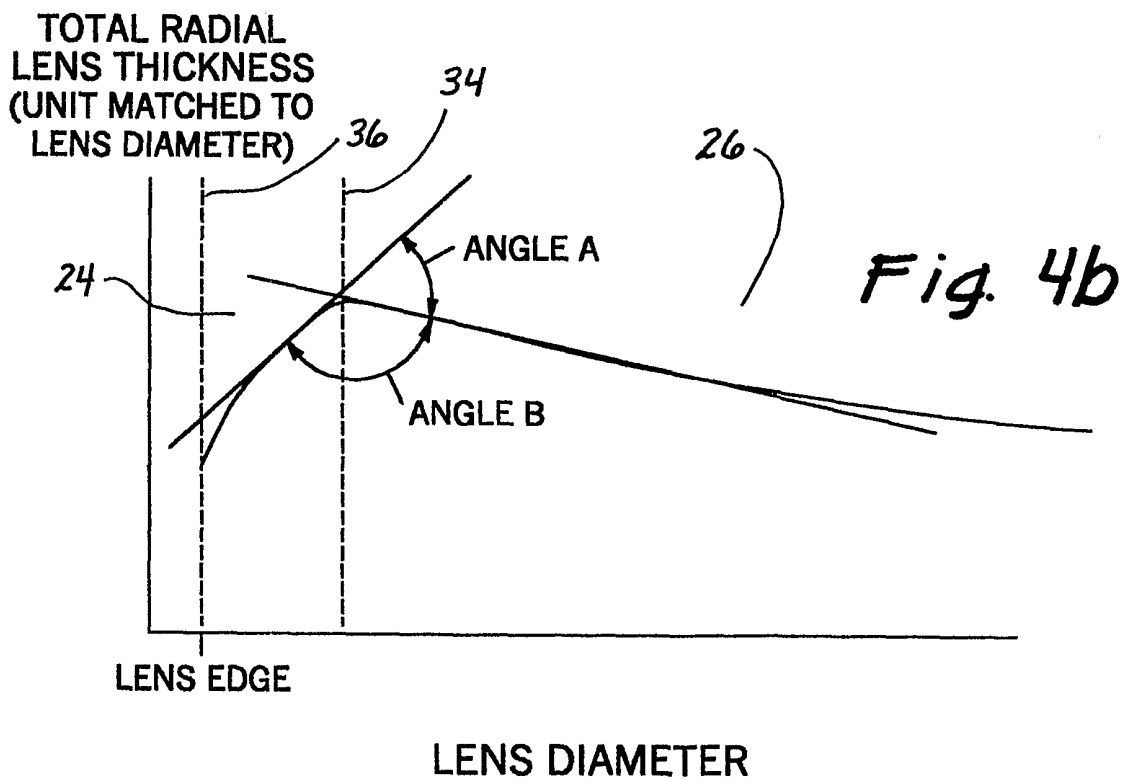
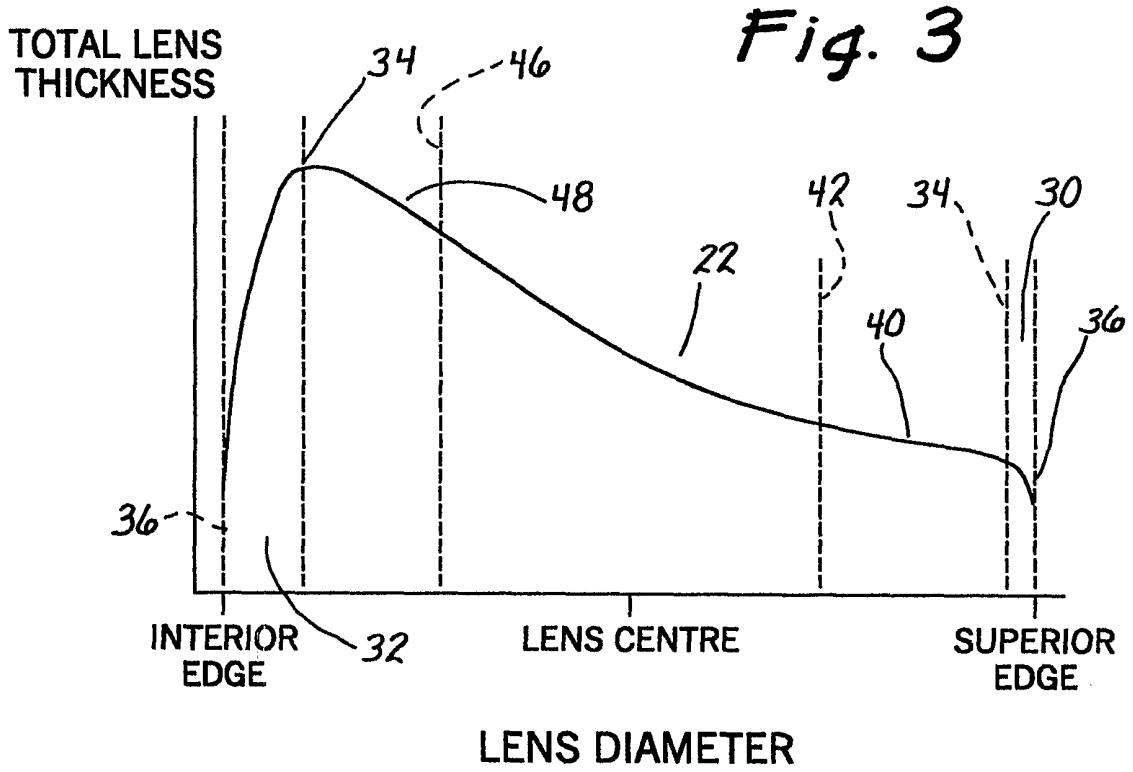

Fig. 2



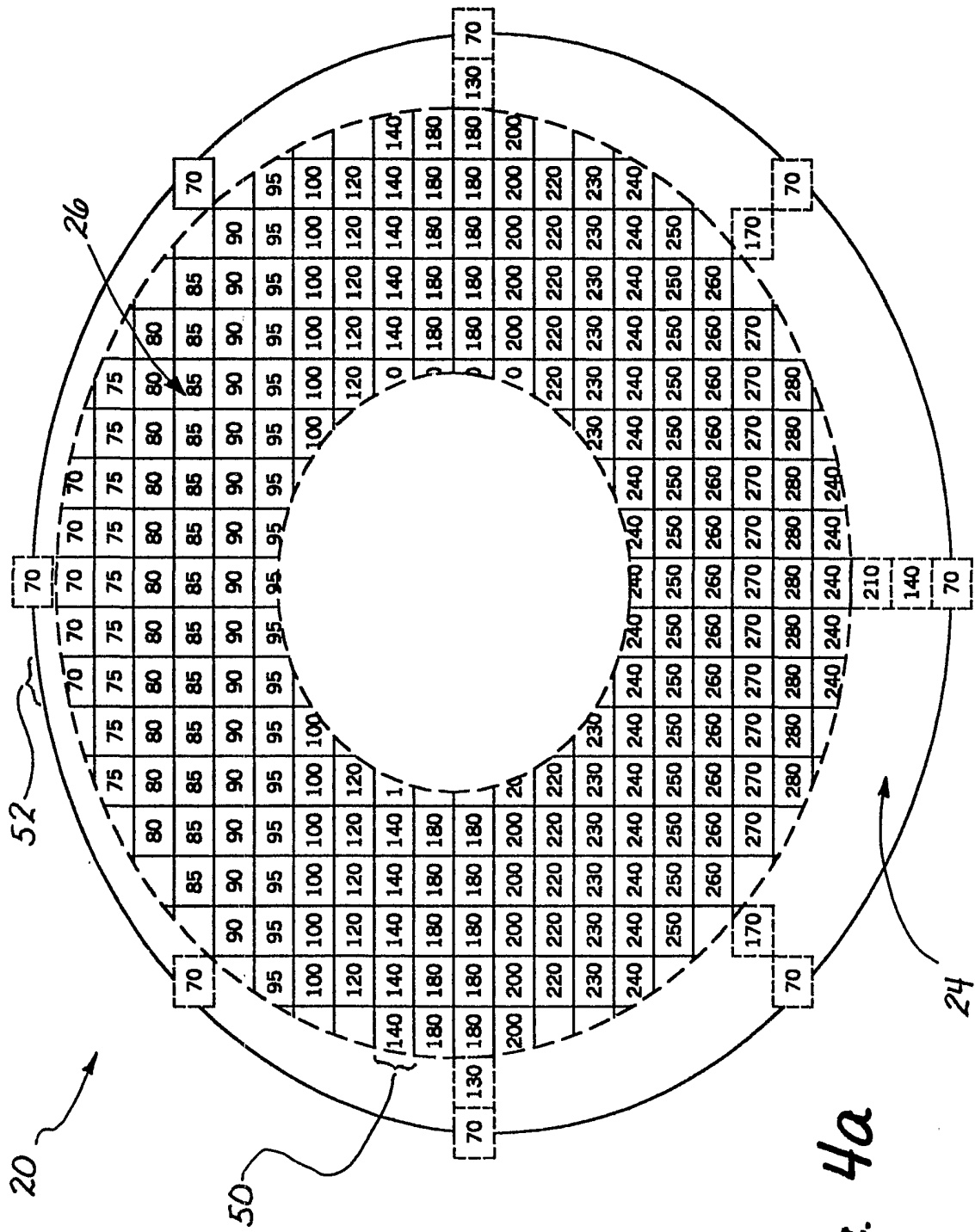

Fig. 4a

Fig. 5a

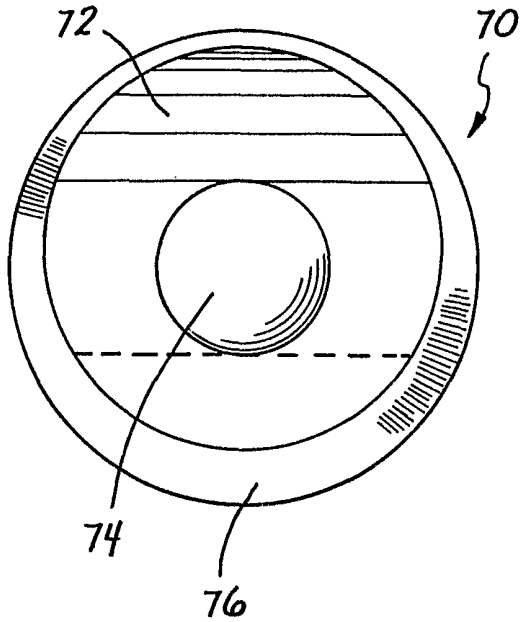

Fig. 5b

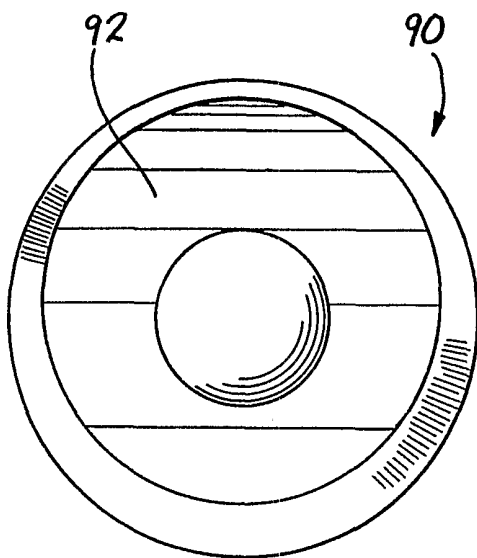
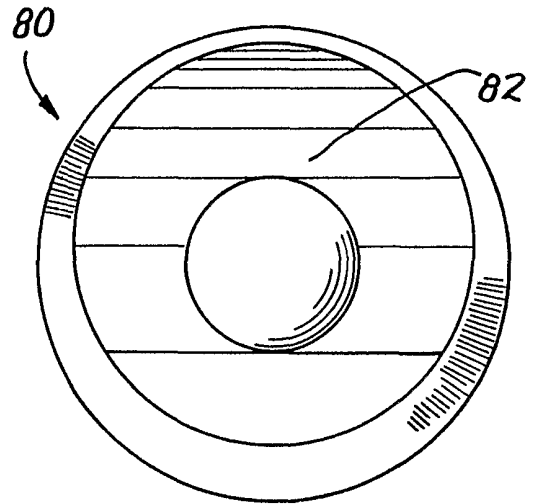

Fig. 5c

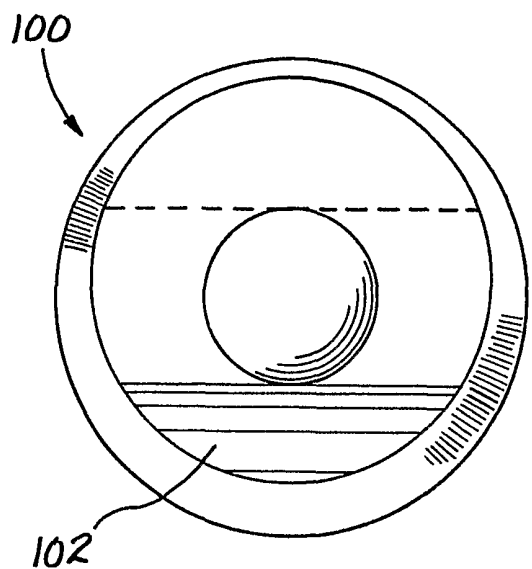

Fig. 5d

Fig. 6a

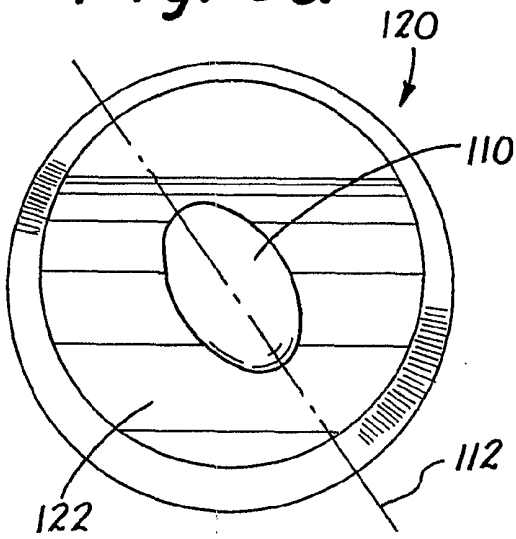
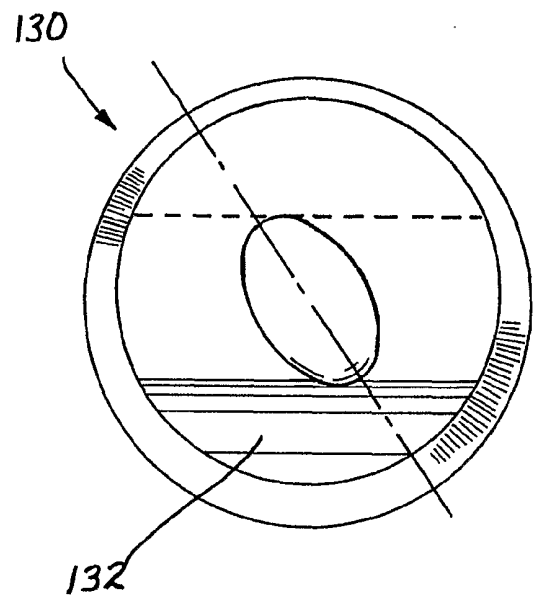
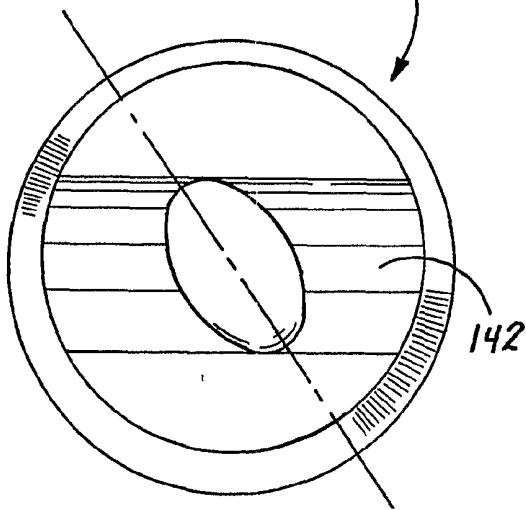

Fig. 6b



140



150

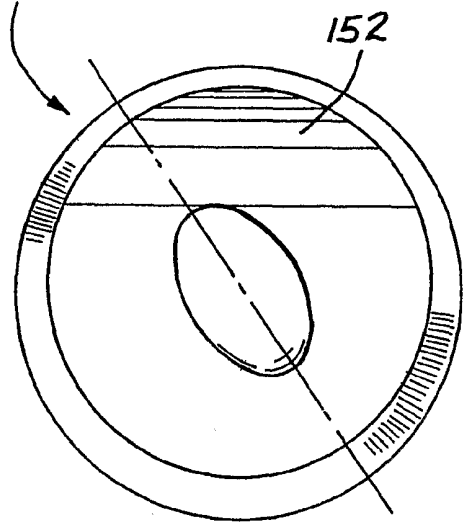

Fig. 6c

Fig. 6d

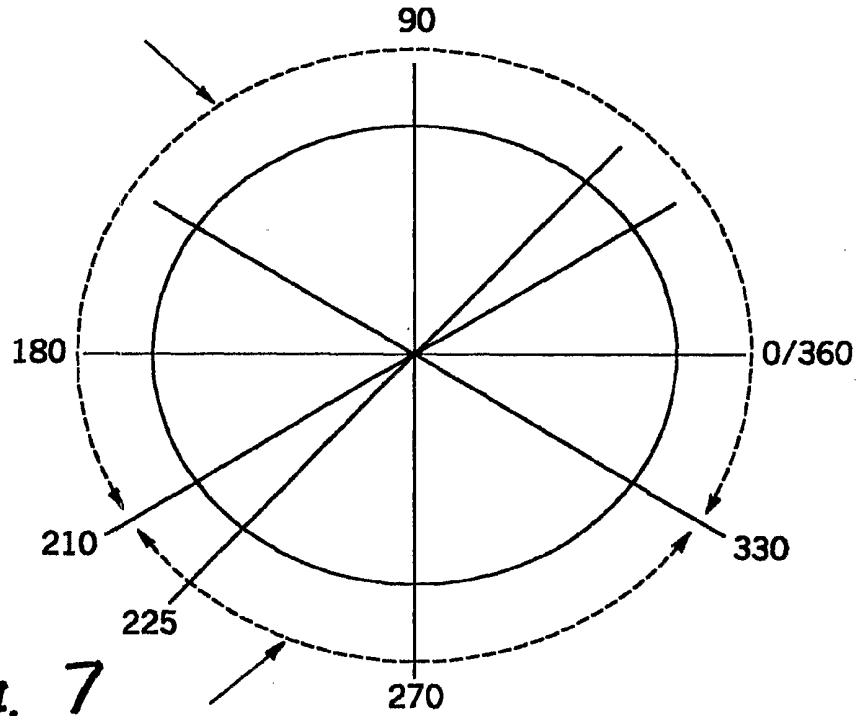

Fig. 7

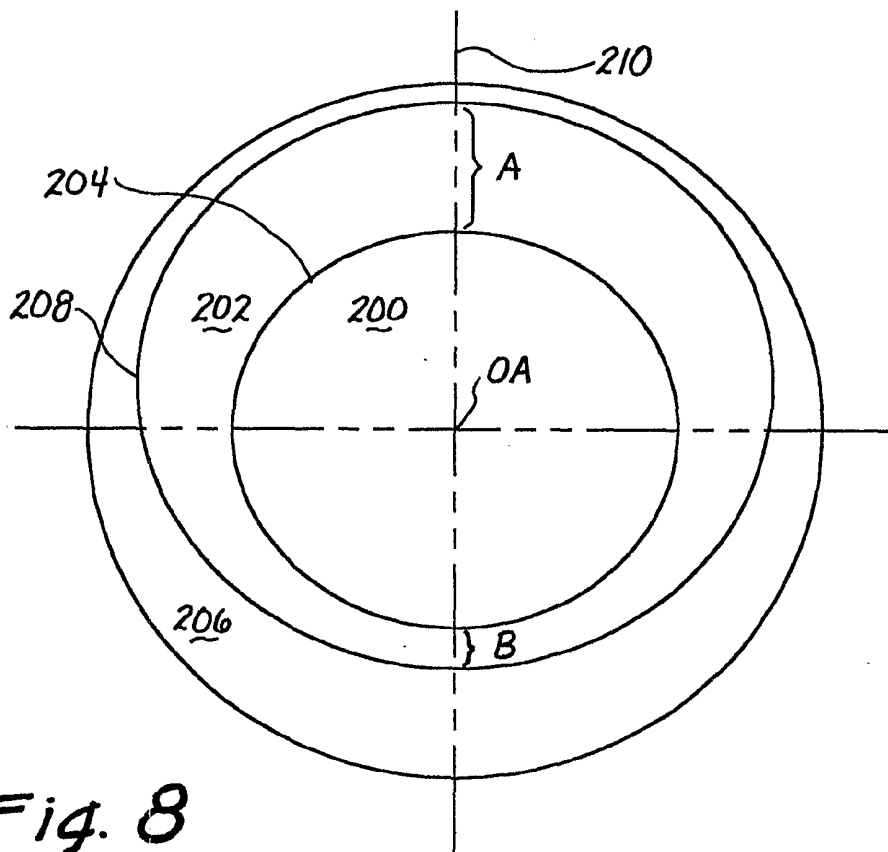

Fig. 8
PRIOR ART

INTERNATIONAL SEARCH REPORT

International application No.
PCT/US01/09923

A. CLASSIFICATION OF SUBJECT MATTER
 IPC(7) :G02C 7/04
 US CL :351/160.R, 161
 According to International Patent Classification (IPC) or to both national classification and IPC

B. FIELDS SEARCHED
 Minimum documentation searched (classification system followed by classification symbols)
 U.S. : 351/160.R, 160.H, 161

Documentation searched other than minimum documentation to the extent that such documents are included in the fields searched

Electronic data base consulted during the international search (name of data base and, where practicable, search terms used)

C. DOCUMENTS CONSIDERED TO BE RELEVANT

Category*	Citation of document, with indication, where appropriate, of the relevant passages	Relevant to claim No.
A	US 5,760,870 A (PAYOR et al) 02 June 1998, (02/06/98) see Figs. 3 and 6.	1-38
A	US 5,650,837 A (ROFFMAN et al) 22 July 1997, (22/07/97) see Fig. 1.	1-38
A	US 5,532,768 A (ONOGI et al) 02 July 1996, (02/07/96) see Fig. 3.	1-38

Further documents are listed in the continuation of Box C. See patent family annex.

* Special categories of cited documents:	"T" later document published after the international filing date or priority date and not in conflict with the application but cited to understand the principle or theory underlying the invention
"A" document defining the general state of the art which is not considered to be of particular relevance	"X" document of particular relevance; the claimed invention cannot be considered novel or cannot be considered to involve an inventive step when the document is taken alone
"E" earlier document published on or after the international filing date	"Y" document of particular relevance; the claimed invention cannot be considered to involve an inventive step when the document is combined with one or more other such documents, such combination being obvious to a person skilled in the art
"L" document which may throw doubts on priority claim(s) or which is cited to establish the publication date of another citation or other special reason (as specified)	"&" document member of the same patent family
"O" document referring to an oral disclosure, use, exhibition or other means	
"P" document published prior to the international filing date but later than the priority date claimed	

Date of the actual completion of the international search 29 MAY 2001	Date of mailing of the international search report 18 JUN 2001
--	--

Name and mailing address of the ISA/US Commissioner of Patents and Trademarks Box PCT Washington, D.C. 20231 Facsimile No. (703) 305-3230	Authorized officer SCOTT J. SUGARMAN <i>J. M. ...</i> Telephone No. (703) 308-0956
---	--