

(No Model.)

11 Sheets—Sheet 1.

C. R. RICHARDS.

MACHINE FOR PRINTING WADS ON BOTH SIDES.

No. 524,610.

Patented Aug. 14, 1894.

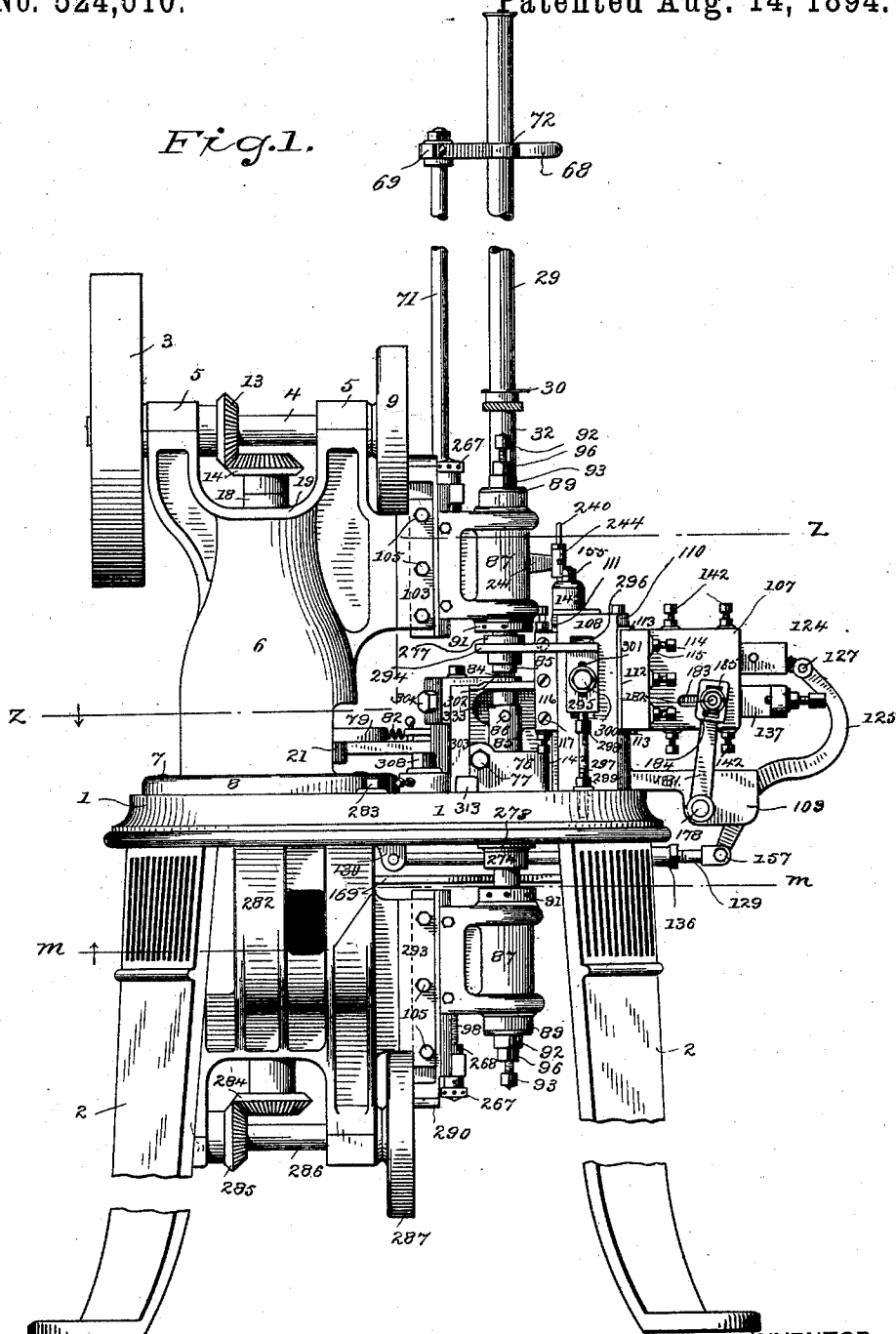

WITNESSES

*H. A. Lambly*  
*S. V. Richardson.*

INVENTOR

*Charles R. Richards*  
By *A. M. Wooster*  
*Atty.*



(No Model.)

11 Sheets—Sheet 3.

C. R. RICHARDS.

MACHINE FOR PRINTING WADS ON BOTH SIDES.

No. 524,610.

Patented Aug. 14, 1894.

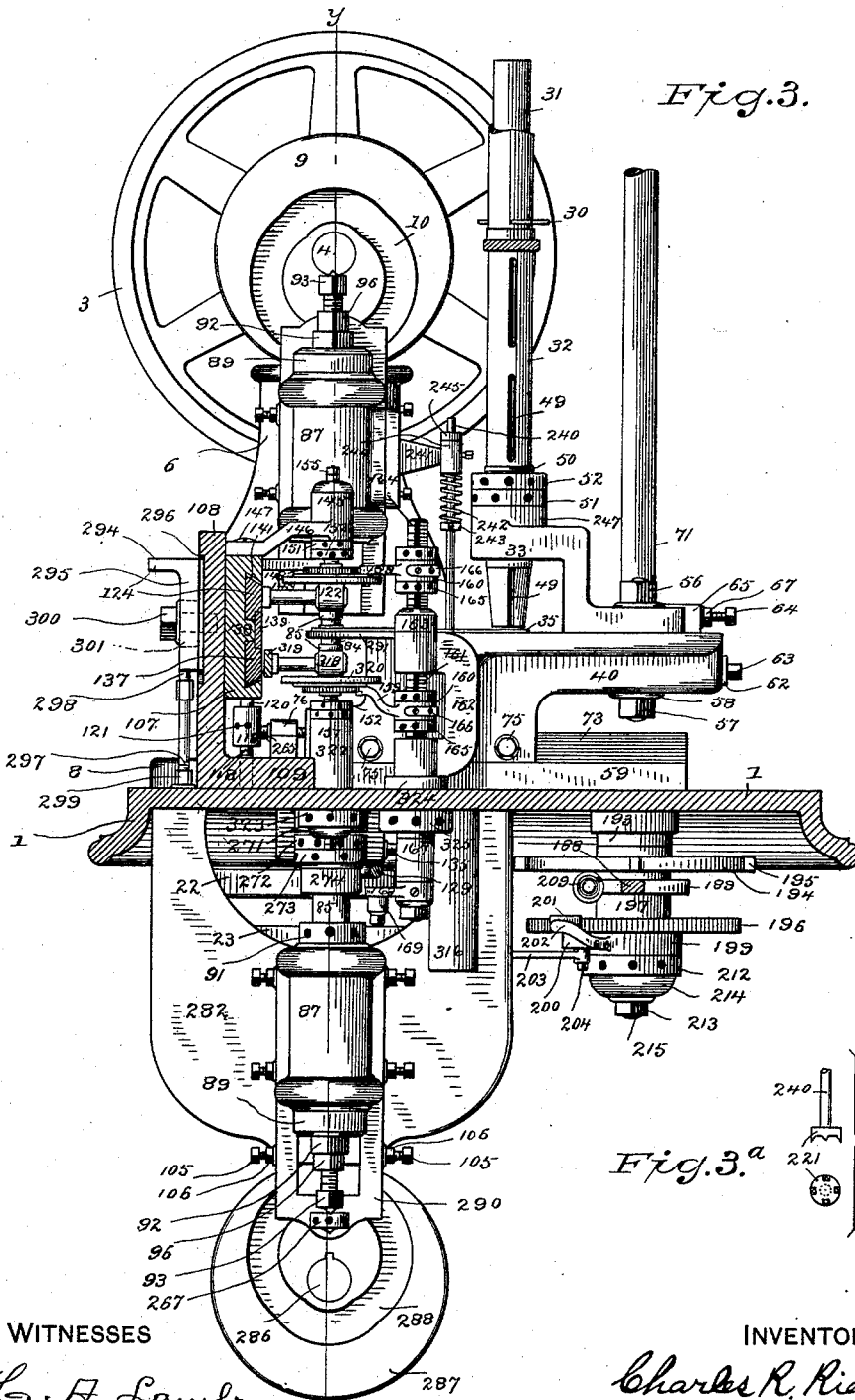

Fig. 3.

Fig. 3. a

WITNESSES

H. A. Lamb,  
S. V. Richardson.

INVENTOR

Charles R. Richards  
By  
A. M. Wooster  
Att'y.

(No Model.)

11 Sheets—Sheet 4.

C. R. RICHARDS.  
MACHINE FOR PRINTING WADS ON BOTH SIDES.

No. 524,610.

Patented Aug. 14, 1894.

Fig. 4.

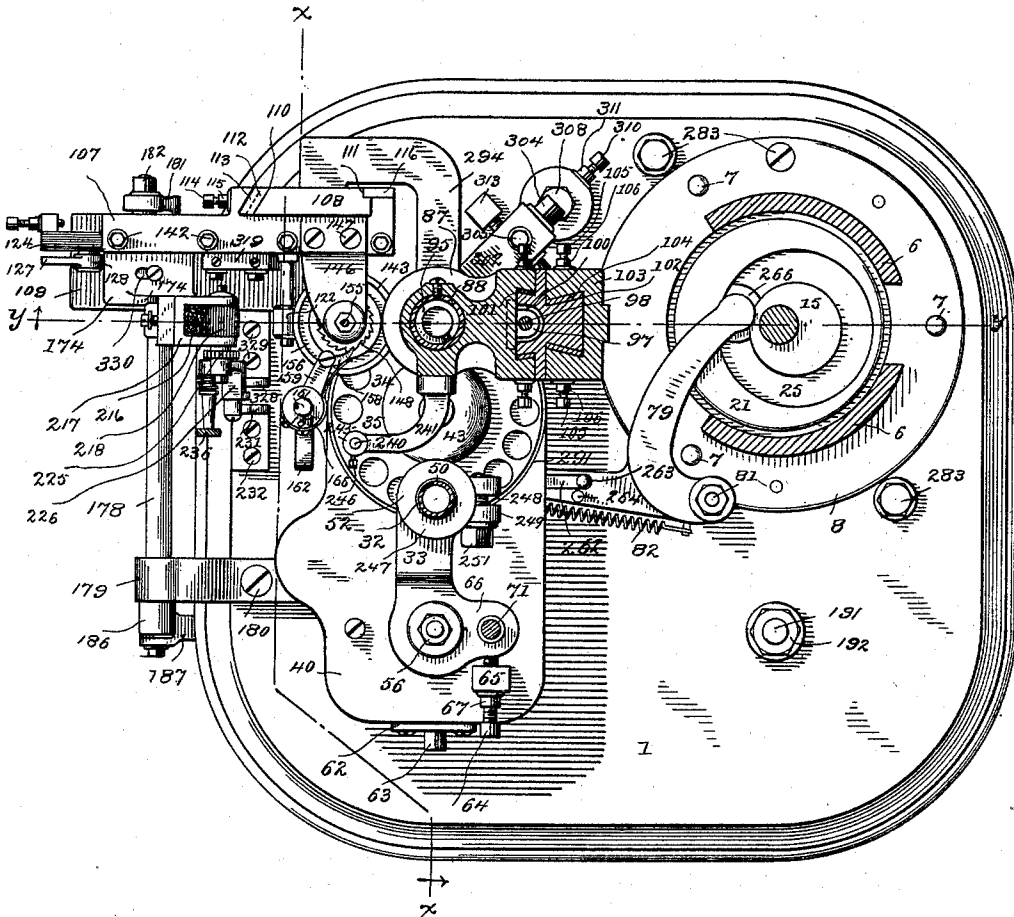

WITNESSES

*H. A. Lundy*  
*S. V. Richardson.*

INVENTOR

*Charles R. Richards*  
By *A. M. Wooster*  
Att'y.

(No Model.)

11 Sheets—Sheet 5.

C. R. RICHARDS.

MACHINE FOR PRINTING WADS ON BOTH SIDES.

No. 524,610.

Patented Aug. 14, 1894.

Fig. 5.

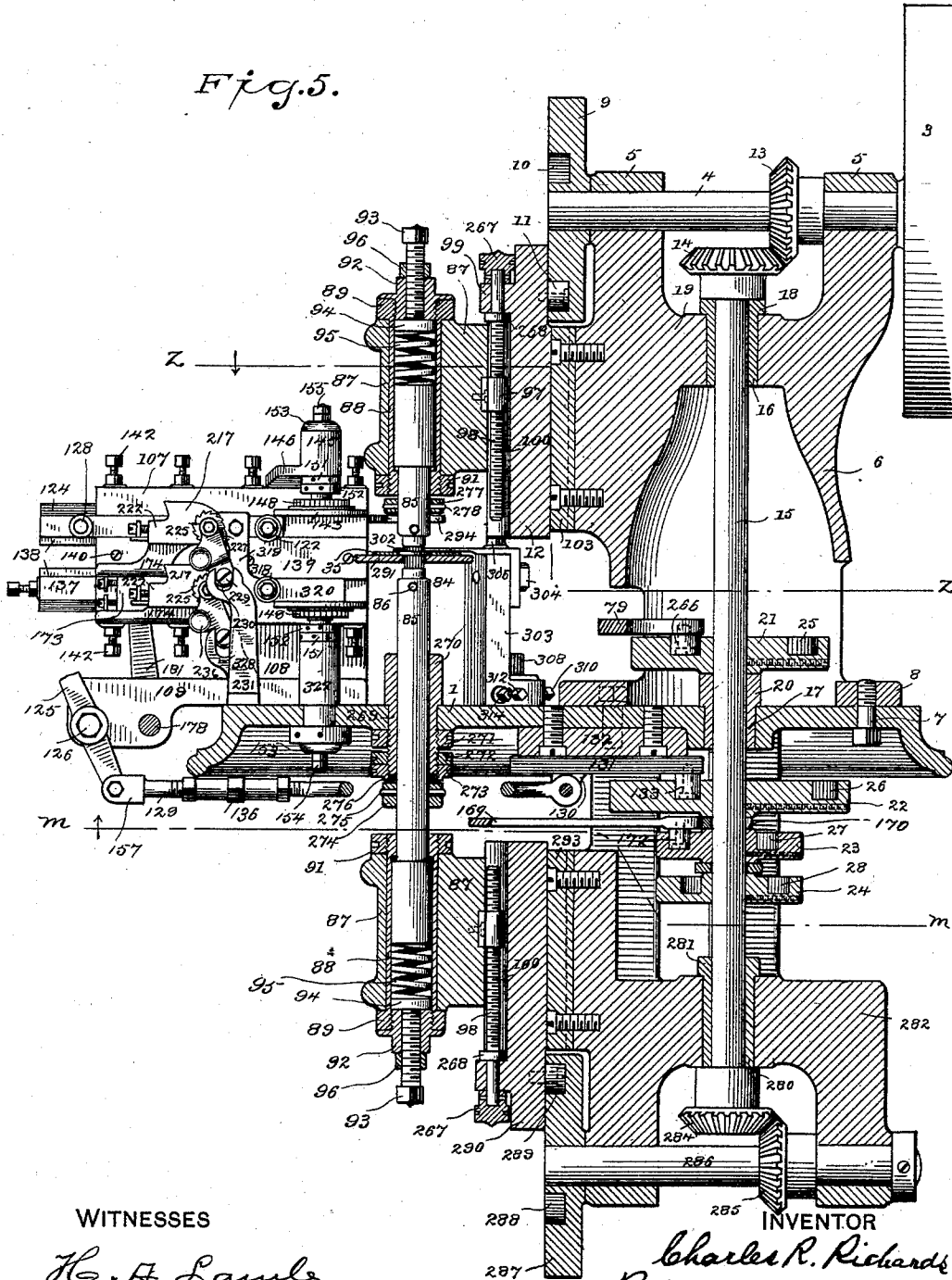

WITNESSES

H. A. Lawley  
S. V. Richardson.

INVENTOR

Charles R. Richards  
By  
A. M. Worcester  
Atty.

(No Model.)

11 Sheets—Sheet 6.

C. R. RICHARDS.

MACHINE FOR PRINTING WADS ON BOTH SIDES.

No. 524,610.

Patented Aug. 14, 1894.

Fig. 6.

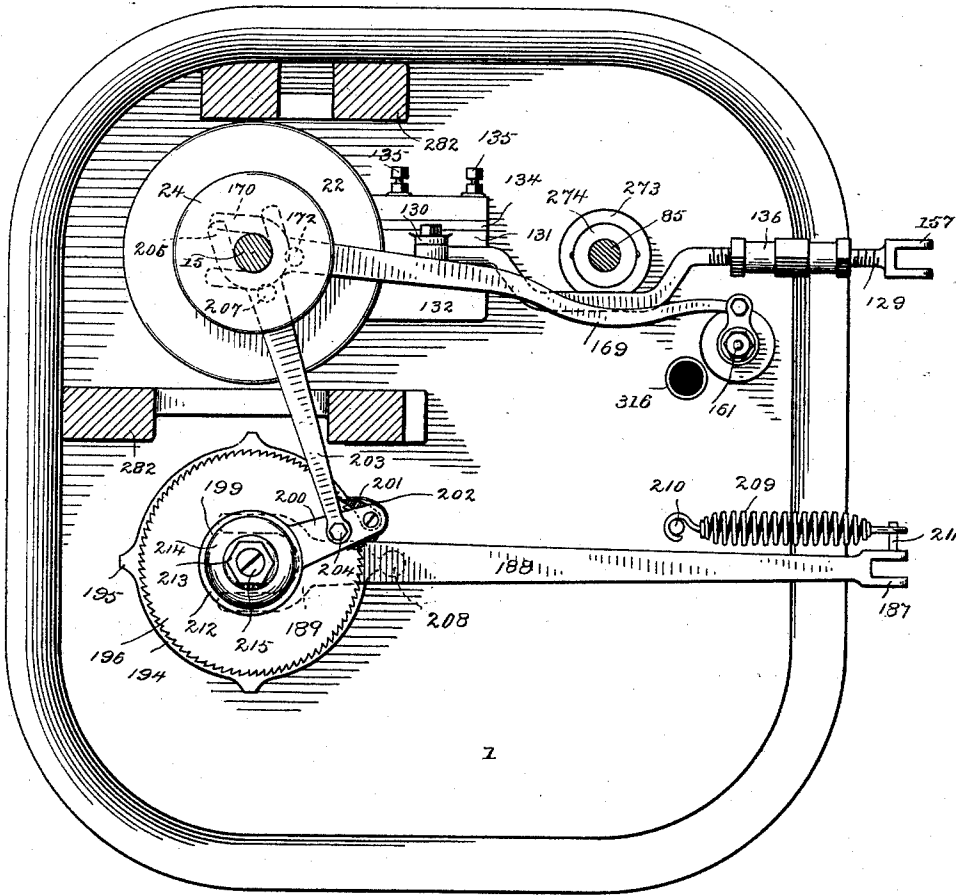

WITNESSES

H. A. Lamb  
S. J. Richardson

INVENTOR

Charles R. Richards  
By A. M. Wooster  
Atty.

(No Model.)

11 Sheets—Sheet 7.

C. R. RICHARDS.

MACHINE FOR PRINTING WADS ON BOTH SIDES.

No. 524,610.

Patented Aug. 14, 1894.

Fig. 7.

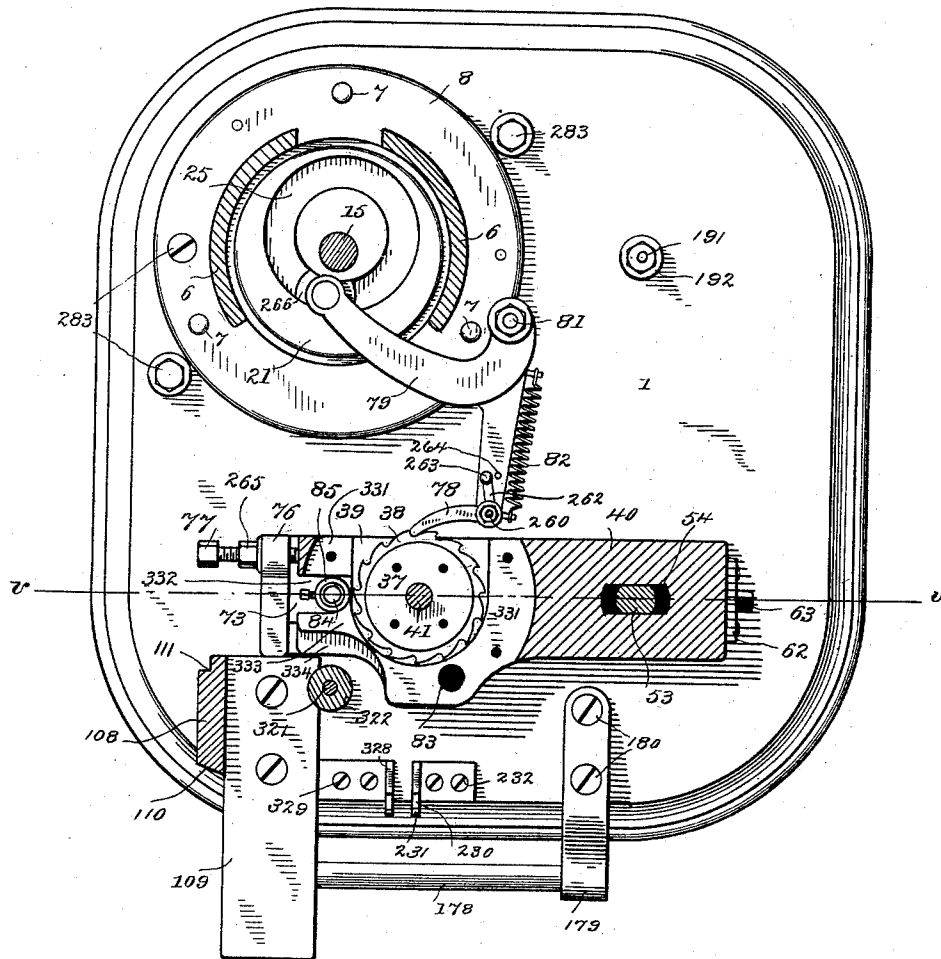

WITNESSES

*H. A. Lamb*  
*S. V. Richardson.*

INVENTOR

*Charles R. Richards*  
*By A. M. Wooster*  
*Atty.*

(No Model.)

11 Sheets—Sheet 8.

C. R. RICHARDS.

MACHINE FOR PRINTING WADS ON BOTH SIDES.

No. 524,610.

Patented Aug. 14, 1894.

Fig. 8.

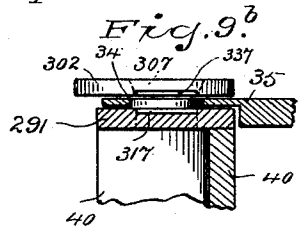
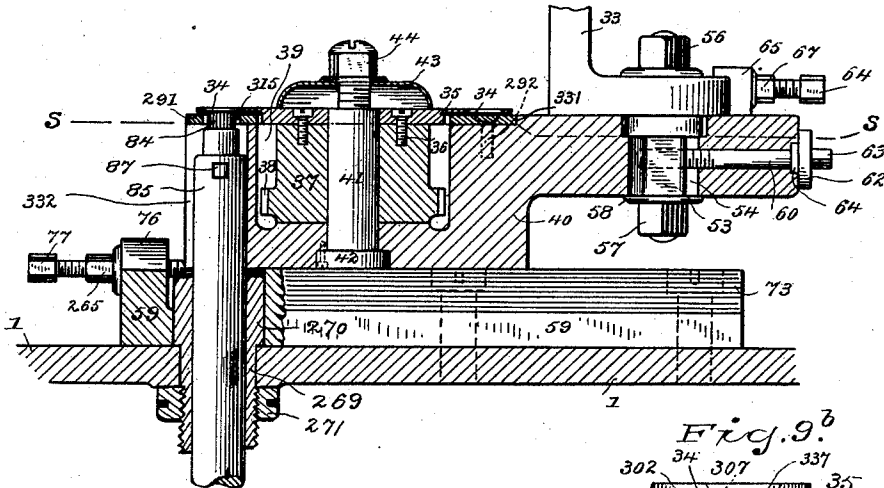

Fig. 9.

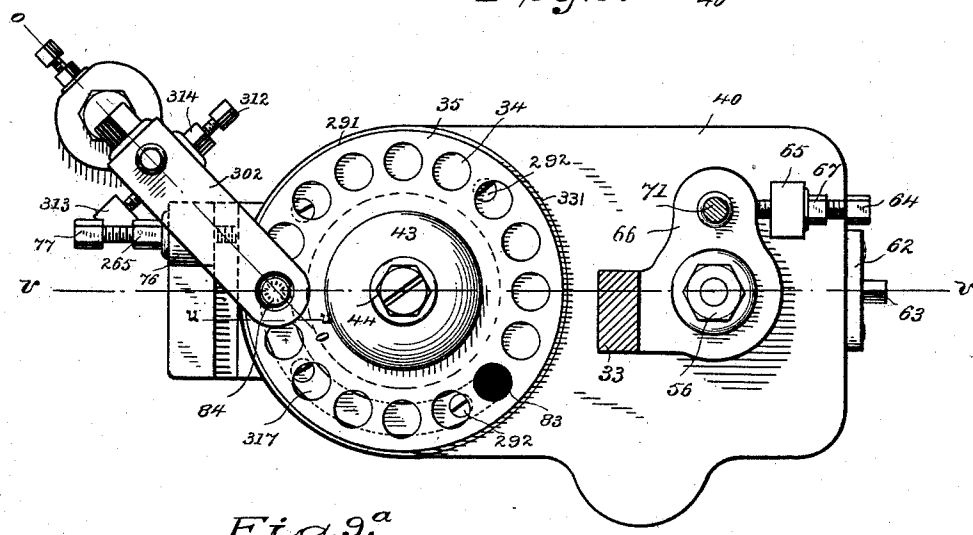
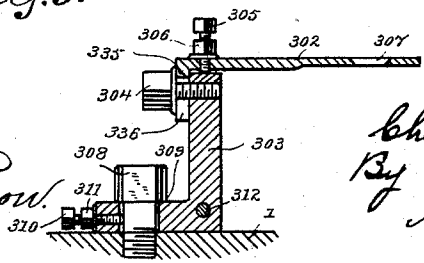

Fig. 9<sup>a</sup>

WITNESSES

*H. A. Lamb*  
*S. V. Richardson*



INVENTOR

*Charles R. Richards*  
 By *A. M. Proster*  
 Atty.

C. R. RICHARDS.

MACHINE FOR PRINTING WADS ON BOTH SIDES.

No. 524,610.

Patented Aug. 14, 1894.

Fig. 10.

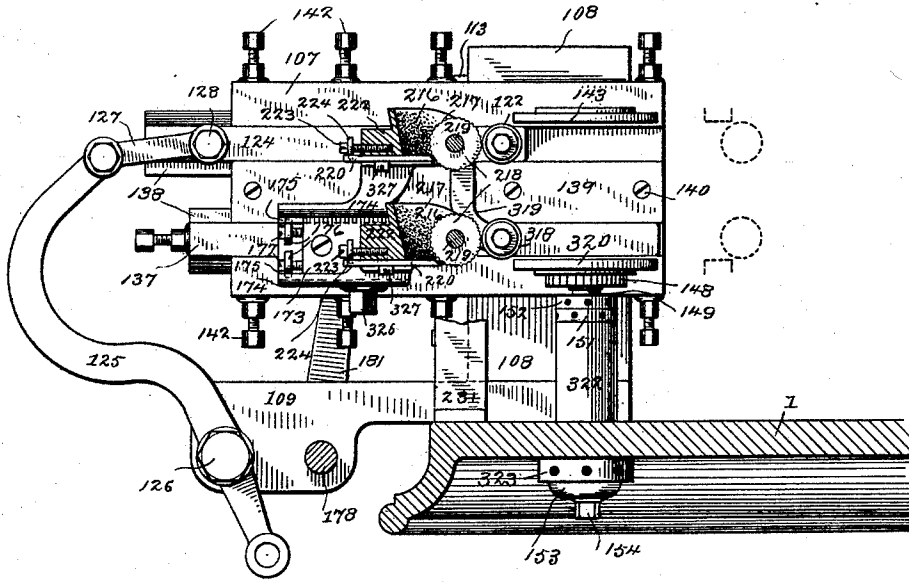

Fig. 10.<sup>a</sup>

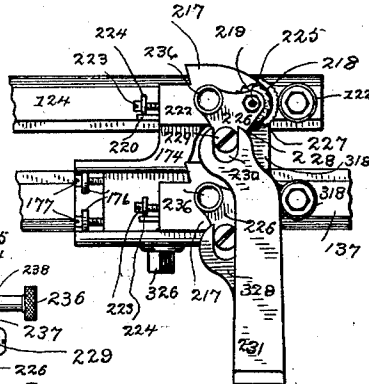
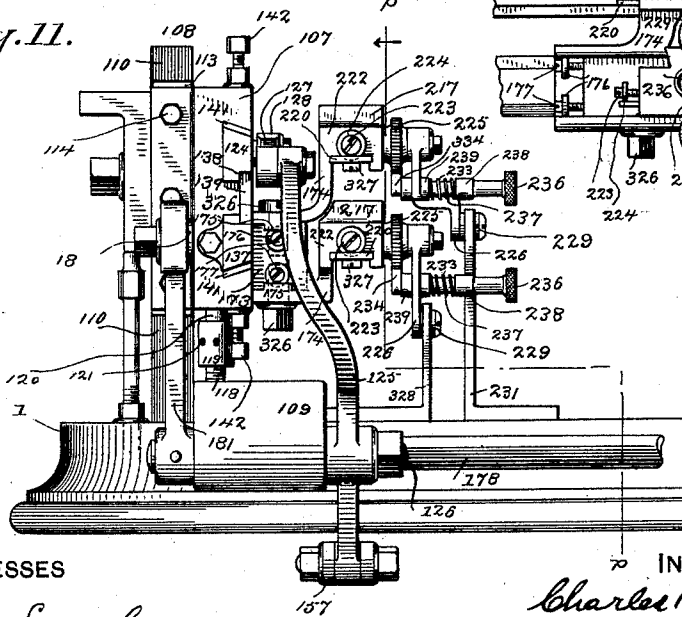

Fig. 11.



WITNESSES

H. A. Lamb  
S. V. Richardson.

INVENTOR

Charles R. Richards  
By  
A. M. Wooster  
Atty.



(No Model.)

11 Sheets—Sheet 11.

C. R. RICHARDS.

MACHINE FOR PRINTING WADS ON BOTH SIDES.

No. 524,610.

Patented Aug. 14, 1894.

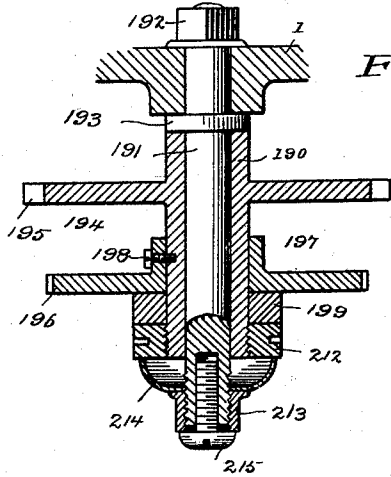

Fig. 15.

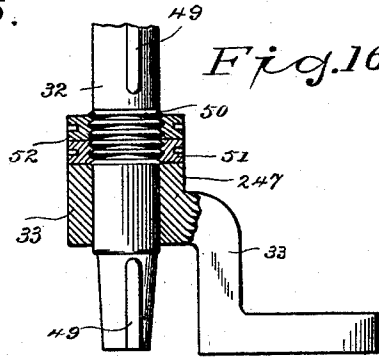

Fig. 16.

Fig. 17.

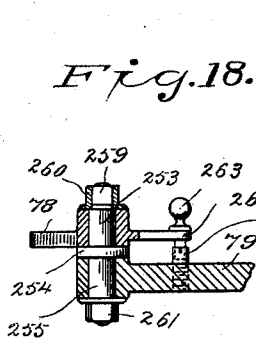

Fig. 18.

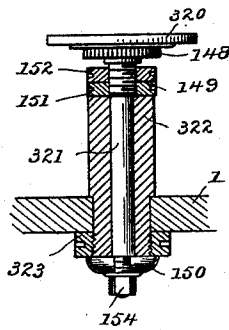

Fig. 19.

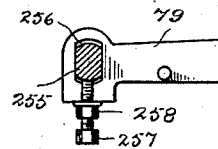
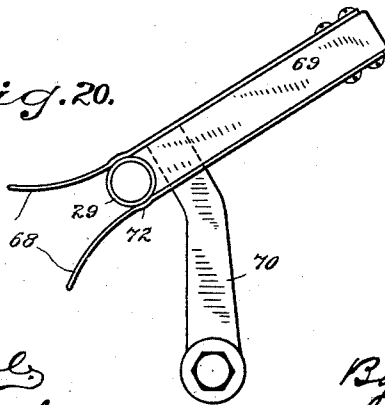

Fig. 20.



WITNESSES

H. F. Lantz  
S. V. Richardson.

INVENTOR

Charles R. Richards  
By  
A. W. Wooster  
Atty.

# UNITED STATES PATENT OFFICE.

CHARLES R. RICHARDS, OF BRIDGEPORT, CONNECTICUT, ASSIGNOR TO  
THE UNION METALLIC CARTRIDGE COMPANY, OF SAME PLACE.

## MACHINE FOR PRINTING WADS ON BOTH SIDES.

**SPECIFICATION** forming part of Letters Patent No. 524,610, dated August 14, 1894.

Application filed April 30, 1894. Serial No. 509,480. (No model.)

*To all whom it may concern:*

Be it known that I, CHARLES R. RICHARDS, a citizen of the United States, residing at Bridgeport, in the county of Fairfield and State of Connecticut, have invented certain new and useful Improvements in Machines for Printing Wads on Both Sides; and I do hereby declare the following to be a full, clear, and exact description of the invention, such as will enable others skilled in the art to which it appertains to make and use the same.

My invention relates to the class of machines illustrated and described in Letters Patent No. 506,374, for a machine for printing wads, granted to me October 10, 1893, and has for its object to perfect certain of the details of construction of said machine and to so improve the machine as a whole that it will print both sides of the wad simultaneously, the requirements being, as stated in my former patent, that the machine shall work rapidly, shall print the wads clearly, shall manipulate them in such a manner that no blurring shall take place and that the machine moreover shall be capable of receiving the finest adjustments and at the same time be simple in construction and not liable to get out of repair.

With these ends in view I have devised the novel machine of which the following description in connection with the accompanying drawings is a specification, numbers being used to designate the several parts.

Figure 1 is a side elevation of the machine complete; Fig. 2 a side elevation on an enlarged scale the point of view being from the side opposite to that in Fig. 1; Fig. 3 a section on the line *xx* in Fig. 4 the inking mechanism being removed and the operative parts of the machine being in end elevation as seen from the left in Fig. 2; Fig. 3<sup>a</sup> a detail view illustrating in side elevation and in inverted plan the lower end of the expelling rod; Fig. 4 a sectional view on the line *zz* in Figs. 1, 2 and 5; Fig. 5 a vertical section on the line *yy* in Figs. 3 and 4; Fig. 6 an inverted plan view corresponding with Fig. 4 portions of the machine being in section on the line *mm* in Figs. 1, 2 and 5; Fig. 7 a section on the line *ss* in Fig. 8; Fig. 8 a section

on an enlarged scale on the line *vv* in Figs. 7 and 9; Fig. 9 a detail plan view corresponding with Fig. 8; Fig. 9<sup>a</sup> a detail sectional view on the line *oo* in Fig. 9; Fig. 9<sup>b</sup> a detail sectional view on an enlarged scale on the line *uu* in Fig. 9, but showing the dial as having advanced to an intermediate position, a wad in one of the holes in the dial appearing in elevation, and the end of the stripper plate also appearing in elevation. Figs. 10, 10<sup>a</sup>, 11, 12, 13 and 14 are views on an enlarged scale illustrating the inking mechanism detached, Fig. 10 being a section on the line *pp* in Fig. 11, and Fig. 11 an end elevation, both of said views showing the position of the parts when the inking rollers are taking ink from the ink supply rollers, Fig. 12 being a side elevation showing the parts at the completion of the forward movement of the inking rollers, Fig. 13 being a similar view showing the position of the parts at the instant a wad is being printed, the inking rollers being at their retracted position as in Fig. 10 but the ink supply rollers being out of operative position, and Fig. 14 being a detail view illustrating the special mechanism for rotating one of the inking rollers the point of view being opposite to that in Figs. 12 and 13, said view being in fact a section on the line *pp* in Fig. 11 but looking toward the right, *i. e.* in the opposite direction from that indicated by the arrow; Fig. 15 a detail sectional view on an enlarged scale illustrating the construction of certain mechanism under the bed, which is shown clearly in elevation in Fig. 2; Fig. 16 a similar view illustrating the construction of the lower end of the wad tube; Fig. 17 a similar view illustrating the construction and adjustment of the lower ink distributing table; Figs. 18 and 19 are similar views illustrating the adjustment of the dial feed pawl, and Fig. 20 is a detail plan view of the tube holder detached.

1 denotes the bed of the machine and 2 suitable legs by which it is supported.

Power is applied to drive the machine by a belt not shown running over a pulley 3 on the shaft 4 journaled in boxes 5 upon a standard, *i. e.*, a heavy casting 6, which rests upon the bed, said standard being held in position by

bolts 7 which extend upward through the bed and engage threaded holes in the base 8 of the standard.

9 denotes a disk at one end of shaft 4 having a cam groove 10 which is engaged by a roller 11 carried by a slide 12 which carries the upper printing die or types as will be fully explained.

13 denotes a bevel gear on shaft 4 which engages a corresponding bevel gear 14 on a vertical shaft 15 which is journaled in upper, middle and lower bushings denoted respectively by 16, 17 and 280, bushing 16 having a flange 18 which rests upon a web 19 in standard 6, the bushing extending through said web, bushing 17 having a flange 20 which rests upon the top of the bed, the bushing itself extending through the bed as shown in Fig. 5, and bushing 280 having a flange 281 which rests upon a casting 282 secured to the under side of the bed by means of bolts or screws 283, see Figs. 2 and 4, said bushing extending through the casting as shown in Fig. 5. At the lower end of shaft 15 is a bevel gear 284 which engages a corresponding bevel gear 285 on a shaft 286 journaled in casting 282. This shaft carries a disk 287 having a cam groove 288 which is engaged by a roller 289 carried by a slide 290 which carries the lower printing die or types as will be fully explained.

The several mechanisms of the machine with the exception of the printing dies or types are driven by means of disks 21, 22, 23 and 24 on shaft 15, disk 21 being above the bed, and disks 22, 23 and 24 being below the bed, and each of said disks being provided with a cam groove, said grooves being denoted respectively by 25, 26, 27 and 28, cam groove 25 being in disk 21, &c.

For convenience in description I will state here that the mechanism by which the wad carrying dial is moved is driven from disk 21, the inking rollers are driven from disk 22, the ink distributing tables are driven from disk 23 and the ink supplying mechanism is driven from disk 24.

The wads are fed to the machine in tubes 29 each wad tube being provided with a cutoff 30 in its lower end and a weight 31 being placed above the wads in the tube to force them downward. The wads are placed in the tubes in any suitable manner and when a tube is exhausted another one is put in its place and the cutoff drawn out to let the wads pass downward. The machine does not require to be stopped in changing tubes. The wads as they leave the tubes pass into a wad receiver 32 which is carried by a bracket 33, see Figs. 3 and 16. At the inner end of this bracket is a head 247 having a slot 248 in one side, and on opposite sides of the slot ears 249, through which a screw 250 passes, see Figs. 2 and 4. One end only of this screw is threaded the other end passing loosely through the ear and being provided with a head 251 adapted to be engaged by a hand piece 252 for conven-

ience in operation. The hand piece is made detachable, but is ordinarily allowed to remain on the head so that if necessary the wad receiver may be removed without an instant's delay and a new one substituted and clamped in place by a movement of the hand piece. From the wad receiver the wads pass into holes 34 in a dial 35. The edge of the dial, *i. e.*, the operative portion, is made the exact thickness of the wads themselves, the central portion of the dial being made thicker, see Fig. 8, and being attached by means of screws 36 to a drum 37 the periphery of which is provided with teeth comprising a ratchet 38. The drum and ratchet lie in a recess 39 in a casting 40 which is movable transversely to the bed in the manner which I will presently describe. The dial turns upon a standard 41 which extends upward through the casting said standard being provided with a head 42 and being locked in position by a set screw passing through the head and engaging the casting. The edge of the dial rests upon a ring 291 which lies in a recess 331 in casting 40 and is secured to the casting by screws 292. The casting is also provided with a vertical recess 332 to receive the lower plunger, see Fig. 7, with a transverse recess 333, see Fig. 1 in connection with Fig. 7 which permits the lower inking roller to pass over the surface of the lower die or types as will be more fully explained and with a recess 334, see Fig. 7, which receives the edge of the lower inking table. This recess does not appear in any other view and is not of the essence of my invention, it being merely a removal of metal to accommodate one of the operative parts. After the wads have been placed in holes 34 in the dial they are carried over the surface of the ring, the parts being fitted so accurately that but one wad can pass into a hole at a time thereby wholly preventing any clogging of the wads. This ring is provided with a hole 315, see Figs. 5 and 8, which registers with one of the holes in the dial and with the upper and lower dies or types. The printing of the wads takes place at this point as will be more fully explained.

83, see Fig. 7, denotes another hole through ring 291, through casting 40 and through the bed. This hole registers with a tube 316, see Figs. 2 and 3, through which the printed wads are expelled from the machine as will presently be fully described. Between holes 315 and 83 in ring 291 there is formed a curved groove 317. This groove is slightly wider than the width of the print made by the lower die or types so that as the wad is carried along by the dial over the surface of the ring opposite edges only of the printed wad will engage the surface of the ring, the central, that is, the printed under side of the wad being over the groove so that blurring of the print is wholly prevented and the ink on both sides of the printed wad is permitted to dry more or less during the time that elapses between the printing of the wad and the instant

of its expulsion from the machine. The upper end of the standard is reduced and screw threaded to receive a curved spring disk 43 which bears upon the top of the dial, the pressure of the spring disk on the dial being adjusted by a nut 44 engaging the threaded end of the standard, and said nut being locked in position by a lock screw 215. This construction will be found clearly illustrated in connection with another part of the machine in Fig. 15, which see in connection with Fig. 8. This spring disk is in practice so adjusted as to produce sufficient friction to stop the forward movement of the drum and dial the instant the application of power to the ratchet ceases.

The construction of wad receiver 32 and bracket 33 by which it is carried will be clearly understood from Figs. 3, 4, 8 and 16. The wad receiver is provided with slots 49 in order that the operator may see if the wads are feeding properly, and with an external screw thread 50. The lower end of the wad receiver is passed through a hole in the bracket in which it is adjusted vertically by means of a nut 51 which engages the thread and rests upon the top of the bracket, being held therein by screw 250 engaging ears 249 as already described. After adjustment nut 51 is locked in position by a check nut 52. In addition to this vertical adjustment the wad receiver has an adjustment toward and from the dial and also a lateral oscillatory adjustment. The bracket carrying the wad receiver is carried by a stud 53 which lies in an opening 54 in casting 40. The stud is made flat sided and the opening shaped to correspond therewith so as to prevent the stud from turning therein, see Figs. 7 and 8. The stud is also provided with a collar 55 which rests on the bottom of an enlargement of the recess. The upper end of the stud is threaded and is engaged by a nut 56. The lower end of the stud is also screw threaded and is engaged by a nut 57 which bears against a washer 58, the latter engaging the under side of the casting, this portion of which overhangs the supporting plate 59 upon which the casting is adjustable as will be more fully explained.

The adjustment of the wad receiver toward or from the dial is effected by means of a screw 60 which turns freely in the casting and engages stud 53, said screw being provided with a collar 61 which lies in a corresponding recess of the casting, and being retained in position by means of a plate 62 secured to the outer side of the casting. The outer end of the screw is squared as at 63 to receive a wrench when it is required to adjust the wad receiver in or out relatively to the dial. The oscillatory adjustment of the wad receiver is effected by means of a screw 64 which passes through a block 65 on the casting and bears against an arm 66 extending outward from bracket 33, see Fig. 4.

Should it be required at any time to ad-

just the wad receiver toward or from the dial nut 57 is loosened and screw 60 turned toward the right or left as may be required to impart the required inward or outward movement to the bracket and wad receiver. After the parts have been adjusted they are locked in position by tightening up nut 57.

Should it be required to give to the wad receiver slight lateral adjustment nut 56 is loosened and screw 64 is turned either in or out as may be required, it being of course understood that the end of said screw bears at all times against arm 66. Having secured the desired adjustment of the wad receiver and bracket, the parts are locked in position by tightening the nut 56. In order to prevent the possibility of screw 64 moving to the slightest extent in use I provide a check nut 67 which must be turned backward before the screw can be turned. Having set the screw to give the required adjustment to the bracket it is locked there by tightening up the check nut. The lower ends of the wad tubes simply fit down into the upper end of the wad receiver which is made just large enough to receive them.

The upper ends of the wad tubes are supported by springs 68 secured to a block 69 upon an arm 70 extending from the upper end of a rod 71, see Figs. 1 and 6, the lower end of said rod being rigidly secured in arm 66 of bracket 33. The springs are curved as at 72 to just receive and hold the tube locking it firmly in position but permitting it to be easily removed when exhausted and a filled tube substituted in its place.

In addition to the adjustments of the wad receiver just described casting 40 is movable bodily transversely of the bed, carrying with it the dial, wad receiver, wad tube and the various parts just described. Supporting plate 59 upon which the casting rests is rigidly secured to the bed and is provided with a dovetail 73, this dovetail engaging a corresponding way in the under side of the casting, a gib 74 being placed between the dovetail and the way, said gib being adjustable by set screws 75 which are provided with lock nuts, see Figs. 2 and 3. This construction enables me to move the dial and all the parts operating in connection therewith out from under the dies or types should it be necessary to remove any of said parts from the casting for any purpose whatever.

At one end of supporting plate 59, see Fig. 8, is a block 76 through which a screw 77 passes. The inner end of this screw serves as a stop to determine the inward movement of casting 40 in moving it back to place. Having once given to screw 77 the proper adjustment it is secured in position by a lock nut 265. Intermittent rotary motion is imparted to the dial by means of a pawl 78 pivoted to one arm of a lever 79. This lever is practically a bell crank lever, the two arms being at approximately right angles to each other. The lever is provided with a sleeve 80 which

turns on a stud 81 extending upward from the bed, said stud constituting the fulcrum of the lever. The pawl is retained in engagement with the ratchet by means of a spring 82 one end of which is connected to the pawl, the other to the lever.

The special construction of pawl 78 is clearly illustrated in Figs. 18 and 19 in connection with Fig. 7.

253 denotes a stud on which pawl 78 is pivoted, and which is provided with a collar 254 which rests upon the top of lever 79, and below said collar is a portion 255 which is flat sided and of greater size one way than the other. This flattened portion passes through a slot 256 at the inner end of the inner arm of bell crank lever 79.

257 is a set screw in lever 79 the inner end of which passes into the slot and against which one edge of portion 255 of the stud rests. This set screw is locked in position after adjustment by check nut 258. The upper end of stud 253 is reduced and threaded as at 259, said threaded portion being engaged by a nut 260 which bears against the shoulder at the lower end of the reduced portion. The lower end of said stud is also threaded and is engaged by a nut 261.

It will of course be apparent that nut 260, will retain the pawl in position on the stud and nut 261 will hold the stud in position in the slot in lever 79, the tightening up of the nut drawing the collar against the lever. Stud 253 is additionally held in position by the set screw 257 it being apparent that the pressure in use is all in the direction of the screw. This set screw affords a very fine adjustment in setting the pawl in position and also serves as a stop to prevent the stud which carries the pawl from being moved out of position after adjustment. At the inner end of the pawl is an angle arm 262 which is provided with a hand piece 263 for convenience in disengaging the pawl from the ratchet when it is desired to move casting 40 and the parts carried thereby out from under the dies or types.

264 is a stop pin in lever 79 which prevents the possibility of the pawl being thrown far enough away from the ratchet under any circumstances to permit it to become permanently disengaged. Should the pawl be thrown violently away from the ratchet arm 262 will come in contact with the stop pin and the pawl will at once drop back to place. At the outer end of the other arm of lever 79 is pivoted a segmental slide, block or shoe 266, see Figs. 4 and 7, which engages cam groove 25 in disk 21, each rotation of said disk causing an oscillation of the arm carrying the pawl and consequently producing a backward movement of the pawl over the face of the ratchet and a forward movement of the pawl which carries the ratchet and with it of course the drum and dial forward the exact distance that the pawl moves. As already stated the ratchet, drum and dial are prevented from

moving any farther than the exact distance they are carried by the pawl, by the pressure of spring disk 43 upon the upper surface of the dial.

The wads after being dropped into the holes in the dial from the wad receiver are carried around into position to be acted on by the printing mechanism which I have arranged directly opposite the point at which the wads pass into the dial. The printing is done by dies or types 84 which are locked in recesses at the ends of plungers 85 by set screws 86. Vertical movement is imparted to the plungers by carriers 87 in which the plungers are socketed. The construction of the carriers will be clearly understood from Fig. 5. Each carrier is provided with a vertical recess in which is a sleeve 88 externally screw threaded at its inner end and internally screw threaded at its outer end, and provided with an enlargement 89 which rests upon the end of the carrier. The threaded end of sleeve 88 extends beyond the carrier and is engaged by a nut 91. The internal thread at the outer end of the sleeve is engaged by a flanged nut 92. An adjusting screw 93 passes through the flanged nut and bears upon a washer 94 within the sleeve. A coil spring 95 is interposed between the plunger and the washer, this spring being sufficiently rigid to insure a perfect print upon a wad but at the same time yielding sufficiently to prevent the slightest injury to the type under any circumstances. In practice the flanged nut is screwed down tight upon the end of enlargement 89. Adjusting screw 93 is turned in forcing the washer inward as far as may be required to give the required rigidity to the spring. When the screw has been properly adjusted it is locked in position by a set nut 96. On the inner side of each carrier is a lug 97 which may be cast separately and secured thereto as shown in the drawings, or may be cast integral therewith if preferred. This lug is internally screw threaded to receive a screw 98 by which the carrier and the various parts moving therewith may be adjusted vertically.

The head of each screw 98 rests upon, and said screw turns freely in, a lug 99 extending from one of the slides (12 or 290) said slides being provided with grooves 100 to receive lugs 97 on the carriers, lugs 99 on the slides being directly in line with lugs 97. The head of each screw, denoted by 267, is secured in place by a pin and is provided with holes to receive a turning rod, said screws being also provided with collars 268 which lie on the inner sides of lugs 99, and act to hold the screws against endwise movement except as carried by the slides. The portions of the screws which engage lugs 99 on the slides being unthreaded and the portions engaging lugs 97 on the carriers being threaded, it follows that rotation of the screws must necessarily move the carriers and accompanying parts upward or downward relatively to the slides and give to said parts the finest pos-

sible adjustment. The upper slide is provided on its inner face with a roller 11, and the lower slide with a roller 289 which engage respectively cam grooves 10 and 288 in disks 9 and 287, each rotation of said disks acting to impart a complete reciprocation to the slides. The inner and outer sides of the slides are both shaped to form dovetails, the outer dovetails lying in correspondingly shaped grooves 101 in the carriers and the inner dovetails lying in the correspondingly shaped grooves 102 in plates 103 and 293 which are respectively rigidly secured to standard 6 and to casting 282 in any suitable manner, for example by heavy screws as shown in Fig. 5. Gibs 104 are provided on both sides of these dovetails, said gibs being adjustable by means of set screws 105 which are locked in position after adjustment by check nuts 106.

In order to prevent the upper and lower dies or types from striking each other should there be no wad between them when the inward movement takes place I provide means which I will now describe for limiting the movement of each plunger and consequently of the die or types carried thereby. The lower plunger 85 by which the lower die or types are carried passes through a bushing 269 which passes through the bed and is provided with a flange 270 which rests upon the bed. The portion of the bushing below the bed is threaded as shown and carries three nuts indicated respectively by 271, 272 and 273. Nut 271 is turned up tight against the under side of the bed to lock the bushing rigidly in position. The lower nut 273 serves as a stop and is engaged by a block 274 which is rigidly secured to the lower plunger 85 in any suitable manner as by a pin 275. I have shown nut 273 as provided with a flange 276 on its lower side which is engaged by the block. This flange simply adds thickness to the central portion of the nut which engages the screw thread. The upward movement of the lower plunger is regulated by placing nut 273 at the exact position required and locking it there by turning nut 272 down upon it tight, the latter nut serving simply as a check nut. The downward movement of the upper plunger 85 is determined by the engagement of a block 277, which is rigidly secured to the plunger by means of a pin 278 or in any suitable manner, with a stop plate 294 the outer end of which partially incloses the upper plunger as indicated in Fig. 5 so as to provide ample surface for engagement by the block. The shape of this plate may be readily understood by reference to Figs. 1, 3 and 4 in connection with Fig. 5. It will of course be apparent that the exact shape of this plate is not of the essence of my invention, it being simply necessary to provide a plate adapted to be engaged by block 277 and having a very fine adjustment. In the present instance I have shown plate 294 as carried by a block 295 which is adapted to slide vertically in a

groove 296 in standard 108 presently to be described which carries the inking mechanism, see Fig. 3. Block 295 and with it the stop plate is adjusted vertically by means of a screw 297 which engages the bed and bears upon the under side of the block, see Figs. 1 and 3. 298 denotes a head on this screw for engagement by a wrench in adjusting and 299 is a set nut which is turned down to lock the screw in position after adjustment. As already stated block 295 slides in a groove in standard 108, it being immaterial whether the entire block engages the groove or whether the groove is made narrower as shown in Fig. 1 and is engaged by a reduced portion of the block. The block and stop plate are rigidly secured in position after adjustment by a bolt 300 which passes through a slot 301 and engages standard 108. It will be seen that I am thus enabled to give a very fine adjustment to both upper and lower plungers.

It is of course required in practice that the die or types carried by both plungers strike the opposite sides of the wad with sufficient force to give a clear and sharp impression upon the wad. On the other hand it is absolutely necessary that the upper and lower dies or types should be prevented from coming in contact with each other should there be no wad in the special hole in the dial which registers with the dies or types when the inward movement takes place. This is accomplished by the adjustment just described.

It will be seen that the several exceedingly fine adjustments just described enable me to secure what is practically absolute accuracy in adjusting the parts, it being practicable to take up wear from use in any portion of the machine so as to retain perfect accuracy of adjustment for any reasonable length of time.

It will of course be understood that the several parts of the machine are timed to correspond with each other, each rotation of shaft 4 causing a forward movement of the dial, presenting a new wad to be printed, and also causing a reciprocation of the slides, carriers, types, &c., whereby the wad is printed on both sides. After receiving the impact of the type in printing the wad is prevented from being lifted out of the hole in the dial by means of a stripper plate 302, see Figs. 1, 4, 5 and 9, which is provided with an attaching arm 335 having a slot 336, and is secured to a bracket 303 by a screw 304, which passes through the slot. This stripper plate is provided with a hole 307 which is adapted to register with the holes in the dial but is smaller so as to prevent the possibility of the wad being drawn out from the hole in the dial when the upward movement of the upper plunger takes place. At the outer end of the stripper plate on its under side, see Fig. 9<sup>b</sup>, is a curved groove 337 which extends from hole 307 to the edge of the stripper plate at one side of the center. The location of this groove when the

parts are assembled corresponds exactly with groove 317 in ring 291, that is to say, one groove is directly above the other. Groove 337 is made slightly wider than the print made by the upper die or types and its purpose is to prevent the print upon the upper side of the wad from being blurred by the stripper plate as the printed wad is carried along by the dial. There is ordinarily no contact between the wads and the stripper plate but under certain circumstances however, the edges of the wads may be sufficiently ragged to prevent the wads from fitting perfectly in the holes in the dial so that contact between the wads and stripper plate is possible. This however, does not affect the operation of the machine to the slightest extent and owing to the fact that the printed portion of the wad is under groove 337 blurring of the print on the upper side of the wad is made impossible, blurring of the print on the under side being made impossible by groove 317 in ring 291. It is of course essential that this stripper plate be capable of very fine adjustment. This I accomplish in the manner which I will now describe and which will be clearly understood from Figs. 9 and 9<sup>a</sup>. The vertical adjustment is obtained by means of a screw 305 which passes through the stripper plate and bears upon the top of the bracket.

To raise or lower the stripper plate it is simply necessary to loosen screw 304 and turn screw 305 in or out as may be required. Having obtained the desired adjustment screw 305 is locked in position by a check nut 306, and the bracket is locked in position by turning in screw 304. Bracket 303 is secured to the bed by a bolt 308 which passes through slot 309 in the base of the bracket. This slot permits the bracket and stripper plate to be adjusted longitudinally relatively to the dial as will be clearly understood from the drawings. The adjustment is effected by means of a screw 310 which passes through the base of the bracket in the horizontal plane and bears against bolt 308. After the bracket has been given the necessary longitudinal adjustment by means of this screw the screw itself is locked in place by turning down check nut 311 and the bracket is locked in place by turning down bolt 308. Transverse adjustment of the bracket and stripper plate is provided for by means of a screw 312 which passes through the base of the bracket and bears against a stump 313 which extends upward through the bed.

It will of course be understood that both longitudinal and lateral adjustments are effected before bolt 308 is turned down to place, the latter serving to lock the bracket itself. Adjusting screw 312 is provided with a check nut 314 by which it is locked in position after adjustment.

Turning now to Figs. 5, 6, 10 and 12 in connection with the general views I will describe the inking mechanism which is driven from

disks 22, 23 and 24. The entire inking mechanism is carried by a plate 107 which is vertically adjustable on a standard 108 cast integral with or rigidly secured to a plate 109 which is itself rigidly secured to the bed by heavy screws as shown in Fig. 7. The back of plate 107 is so shaped as to form a way to receive standard 108, the standard being preferably beveled upon one side as at 110, see Fig. 1, and provided with a shoulder 111 on the other side, see Figs. 1 and 4.

112 denotes a gib having angle pieces 113 which I place between plate 107 and the standard. This gib may be set up to take up lost motion by means of set screws 114 which are provided with lock nuts 115. The angle pieces act to prevent the possibility of the gib becoming displaced in use. Plate 107 is retained in engagement with the standard by means of a plate 116 which engages shoulder 111 in the standard and is secured to the plate by screws 117.

118 denotes a screw engaging plate 109 and having a head 119 provided with a bearing 120 engaging the under side of plate 107, and with holes 121 to receive a turning rod. It will be seen that the entire weight of plate 107 and the inking mechanism rests upon bearing 120.

Should it be desired at any time to give vertical adjustment to the entire inking mechanism, this result may be accomplished by turning screw 118 either way as may be required to raise or lower plate 107 and the parts carried thereby.

As has already been fully explained slides 12 and 290, carriers 87 and the dies or types receive intermittent reciprocatory motion through the engagement of rollers 11 and 289 on the slides with the cam grooves in disks 9 and 287. It will be seen in Fig. 3 that the shape of the cam grooves is such that when the plungers are at their retracted position they will be held stationary for an instant. The relative position of the types at this moment is clearly shown in Fig. 13. While the types are temporarily stationary at the retracted position they are inked by means of upper and lower inking rollers 122 and 318, the former being carried by a slide 124 and the latter by a bracket 319 rigidly secured thereto. Casting 40 as already stated is provided with a recess 333, see Fig. 1, which permits inking roller 318 to pass over the surface of the die or types carried by the lower plunger. Slide 124 reciprocates in a groove in plate 107, movement being imparted to said slide by means of a lever 125, see Figs. 10 and 13, said lever being fulcrumed on a stud 126 extending outward from plate 109. The lever is connected to the slide by means of a link 127 pivoted to the upper end of the lever and to the slide as at 128.

129 denotes a connecting rod one end of which is provided with a yoke 157 in which the lower end of the lever 125 is pivoted, the other end of said rod being pivoted between

ears 130 on a dove-tail slide 131 moving in ways in a block 132 which is cast integral with or rigidly secured to the under side of the bed. At the inner end of slide 131 is a roller 133 which engages cam groove 26 in disk 22 carried by vertical shaft 15, see Figs. 5 and 6. Connecting rod 129 is suitably curved, see Fig. 6, to avoid interference with block 274 on the lower plunger.

It will of course be apparent that there must be no lost motion whatever or looseness of parts in a machine required to run with the absolute accuracy necessary in machines of this class. In order to insure the necessary perfection of adjustment even after long continued use I place a gib 134 between slide 131 and the block which may be set up at any time by set screws 135. Connecting rod 129 is made in two parts, one part being provided with a right and the other with a left hand screw thread, said threaded parts being engaged by a nut 136. It will be seen that rotation of nut 136 will either lengthen or shorten the connecting rod as may be required thereby changing the position of slide 124 in its groove in plate 107 and of course changing the position of the inking rollers. Below slide 124 in a similar groove in plate 107 is a slide 137. The shape of slides 124 and 137 in cross section is clearly shown in Fig. 3. On the sides toward each other the slides are both provided with shoulders 138 which are engaged by a plate 139 which is itself secured to plate 107 by screws 140, the sides of the slides below the shoulders being parallel. The opposite sides of the slides are inclined, said slides being widest at the bottom, the grooves being of course correspondingly under-cut to receive them. Gibs 141 are placed between the slides and plate 107 and may be set up to compensate for wear in long continued use by screws 142.

In Fig. 12 the position of the parts is shown at the instant the inking rollers are inking the dies or types and in Fig. 13 the position of the parts is shown at the instant the types are at their inward position, as in the act of printing a wad. At this instant the inking rollers are at their farthest position toward the left, that is away from the types. While the inking rollers are moving backward and also when moving forward again toward the types, they pass over the surface of ink distributing tables 143 and 320, from which the inking rollers receive sufficient ink to ink the types for each impression.

In Fig. 10 the inking rollers are shown as receiving ink from the ink supplying mechanism this being a position of the parts that takes place only once during a pre-determined number of revolutions of shaft 15 and the operating disks, in the present instance, once in eighteen revolutions all of which will presently be fully explained.

Before proceeding to describe the manner in which the ink is supplied to the distributing tables, I will describe the operation of the

distributing tables themselves. The upper ink distributing table, 143, is carried by a vertical shaft 144 which is journaled in a hub 145 carried by a bracket 146 which is rigidly secured to the top of plate 107 by screws 147, see Fig. 4. Just above the table on shaft 144, is a ratchet 148, see Figs. 12 and 13. Above the ratchet is a screw thread 149, and at the upper end of the shaft is another screw thread 150. The vertical adjustment of the table is determined by a nut 151 which engages thread 149. After the table has been fixed at the exact adjustment required it is locked there by means of a set nut 152. Nut 151 is held in contact with the lower side of the hub by means of a curved spring disk 153 which is provided with a central opening through which the upper end of shaft 144 passes, the tension of said spring disk being adjusted by a nut 154 engaging thread 150 and said nut being locked in position after adjustment by a set nut 155. The special purpose of the spring disk is to cause sufficient frictional contact between nut 151 and the hub to insure that the disk and ink distributing table shall be carried forward at each actuation of the machine the exact distance that the operating mechanism moves and no more, that is to say the friction being sufficient to stop the movement of the ratchet and ink distributing table the instant the forward movement of the operating mechanism ceases.

The lower ink distributing table, 320, see Figs. 10 and 17, is carried by a vertical shaft 321 which is journaled in a standard 322 which extends through the bed and upward therefrom, casting 40 being cut away as at 334, see Fig. 7, to receive the edge of the table. The portion of the standard below the bed is screw threaded and is engaged by a nut 323 by which the standard is rigidly held in place. Shaft 321 carries a ratchet 148 and is provided with screw threads 149 and 150 in the same manner as shaft 144. The vertical adjustment is determined by a nut 151 which engages thread 149 and is locked in position by a set nut 152, nut 151 being held in contact with nut 323 by a curved spring disk 153 provided with a central opening through which the lower end of shaft 321 passes and the tension of said disk being adjusted by a nut 154 engaging thread 150, the operation of the spring disk being precisely the same as the similar disk used in connection with the upper ink distributing table which has just been described in detail.

156, see Fig. 4, also dotted lines in Figs. 12 and 13, denotes a groove in the upper surface of the upper ink distributing table which receives any oil that may possibly collect upon the upper side of the table and renders it impossible for any oil to run over the edge of the table and mix with the ink on the under side thereof.

The ink distributing tables are given slight rotary motion at each actuation of the machine by means of pawls 158 pivoted to crank arms 159, see Figs. 3 and 4, extending outward

from blocks 160 which are vertically adjustable on a rock shaft 161 extending above and below the bed, see Figs. 2 and 3. This rock shaft is journaled in a bracket 162, having a flange 324 which rests upon the bed and a threaded portion which extends through the bed and is engaged by a nut 325 by which the bracket is held in place.

163 is a flange on rock shaft 161 which rests upon the top of bracket 162, the weight of said shaft and the parts carried thereby being supported by said flange. 164 denotes screw threads on shaft 161. Blocks 160 are preferably connected to the rock shaft by keys and grooves so as to permit them to be readily adjusted or removed if necessary. When the blocks have been properly adjusted they are locked in position by nuts 165 above and below the blocks. See Fig. 3.

166 denotes springs secured to blocks 160, the free ends of which bear against the pawls and act to hold them in engagement with the ratchets. At the lower end of rock shaft 161 is a hub 167 having extending outward therefrom a crank arm 168 to which a connecting rod 169 is pivoted. At the inner end of this connecting rod is a yoke 170 which embraces shaft 15. This engagement of the yoke with the shaft retains the connecting rod at all times in operative position.

172 is a roller on connecting rod 169 which engages cam groove 27 in disk 23.

It will be seen from the above that each rotation of shaft 15 and disk 23 produces a longitudinal reciprocatory movement of the connecting rod, which in turn through crank arm 168, produces an oscillation of the rock shaft, the backward movement of said shaft causing pawls 158 to move backward over one tooth on ratchets 148 and the forward movement thereof causing the pawls to move the ratchets forward one tooth, the forward movement of the ratchets being stopped as already stated the instant the forward movement of the pawls ceases by friction between nuts 151 and hub 145 and standard 322 caused by spring disks 153.

Turning now to Figs. 4, 5, 10 and 12 I will describe the ink supplying mechanism.

173 is a block extending outward from slide 137. The ink supplying mechanism is carried by brackets 174 which are rigidly secured to slides 175, see Figs. 10 and 11, which are adapted to be adjusted in grooves in the block. This adjustment is effected by means of disks 176 carried by screws 177 which engage the end of the block. The edges of the disks engage recesses cut in the inner sides of the slides as clearly indicated in Figs. 10 and 11. The disks being rigidly secured to the screws it follows that rotation of the latter will move the slides, brackets, and entire inking mechanism longitudinally relatively to the block. The slides are locked in position after adjustment by means of screws or bolts 326, which pass through slots 330 (one appearing in Fig. 4) in the slides and engage

the block. It is of course necessary to loosen the screws before an adjustment can be made in use. Slide 137 by which all of the parts just referred to are carried receives motion in the manner which I will now describe.

178, see especially Figs. 4, 10 and 11, is a rock shaft, one end of which has its bearing in plate 109, and the other end in a bracket 179 which is secured to the bed by screws 180. At one end of this rock shaft is an arm 181 which extends upward, see Figs. 1 and 11, and is connected to slide 137 by a stud 182 which passes through a slot 183 in the back of plate 107 and is rigidly fixed in said slide. The outer end of stud 182 turns freely in a block 184 which slides in a recess 185 at the upper end of arm 181, said block being shown in Fig. 1 and in dotted lines in Fig. 13. At the other end of rock shaft 178 is an arm 186 which extends downward and is pivoted in a yoke 187 at the outer end of a connecting rod 188. At the inner end of said connecting rod is a yoke 189, see Fig. 2, which embraces a short shaft 190 which turns on a stud 191 extending downward from the bed. The upper end of this stud passes through the bed and is threaded to receive a nut 192. Just under the bed is a collar 193 which is drawn up against the bed when the nut is tightened up, thereby locking the parts firmly in position.

194 denotes a disk on shaft 190 which is made integral therewith or rigidly secured thereto, and is provided with bosses 195. In the present instance four bosses are shown on said disk.

196 denotes a ratchet also carried by shaft 190. In the present instance I have shown the ratchet as provided with a hub 197 and as attached to the shaft by a set screw 198. Below the ratchet is a collar 199 which turns freely on the shaft and is provided with an outwardly extending arm 200.

201 denotes a pawl at the outer end of this arm which engages the ratchet, and 202 a spring secured to the outer end of the arm and acting to hold the pawl in engagement with the ratchet.

203 is a connecting rod one end of which is pivoted to arm 200 as at 204, see Fig. 6, the other end being provided with a yoke 205 which embraces shaft 15. This engagement of the yoke with the shaft retains the connecting rod at all times in operative position.

207 is a roller on connecting rod 203 which engages cam groove 28 in disk 24.

It will be seen from the above that each rotation of shaft 15 and disk 24 causes a longitudinal reciprocatory movement of the connecting rod which in turn, through the oscillation of arm 200 moves pawl 201 backward over one tooth of the ratchet and when the forward movement takes place carries the ratchet, shaft and disk 194, having bosses 195, forward a distance depending upon the number of teeth in the ratchet. In the present instance I have shown the ratchet as pro-

vided with seventy-two teeth. It therefore requires seventy-two actuations of the machine, *i. e.* rotations of shafts 4 and 15 and the cam disks carried thereby, to produce one revolution of the ratchet and disk.

Upon the upper side of connecting rod 188 is a roller 208 which is adapted to lie in contact with the surface of disk 194 and to be engaged by the bosses on said disk. A spring 209 one end of which is connected to a pin 210 on the under side of the bed, the other end being connected to a pin 211 extending outward from yoke 187 at the outer end of the connecting rod, acts to hold the roller in contact with the periphery of the disk until said roller is engaged by one of the bosses 195. Each time one of these bosses comes in contact with roller 208 on connecting rod 188 said connecting rod is forced outward longitudinally against the power of spring 209. This movement swings arm 186 outward, oscillates rock shaft 178 and of course swings arm 181 which extends in the opposite direction from arm 186 inward, thereby moving slide 137 and the ink supplying mechanism carried by said slide inward toward the inking rollers, this position of the parts being clearly shown in Fig. 10 as will presently be more fully explained. It will be apparent from the above that this inward movement of the ink supplying mechanism toward the inking rollers takes place in the present instance once in eighteen actuations of the machine, there being seventy-two teeth in the ratchet and four bosses producing this movement on disk 194 which moves with the ratchet. This adjustment of the parts I have found to work perfectly satisfactorily in use. Should it be found necessary to supply ink more or less frequently to the inking rollers, disk 194 would be removed and a new one substituted having more or less bosses 195, for example a disk having two, three or six bosses, it being preferable although not essential, that the number representing the bosses on the disk be contained an even number of times in the number representing the teeth on the ratchet. Shaft 190, the disk, ratchet, collar, &c., are retained upon stud 191 in the manner which I will now describe. Shaft 190 is threaded at its lower end and is engaged by a nut 212, collar 199 lying between the ratchet and this nut, the nut being screwed up tightly enough to prevent lost motion but without interfering with the free movement of the collar. It is of course essential however, that the ratchet shall not be carried forward any more than the exact distance the pawl moves. This result I accomplish by a friction device similar to the ones used in connection with the dial feed ratchet, and the feed ratchets which carry the ink distributing tables. The lower end of stud 191 is screwed and is engaged by a nut 213.

214 denotes a curved spring disk having a central opening through which the lower end of the stud passes. The edge of this disk

bears upon nut 212. It will be seen therefore that the action of this spring disk is to press nut 212, shaft 190 and all the parts carried thereby upward, the upper end of said shaft bearing against collar 193. Nut 213 is turned against the disk until sufficient friction is produced to stop the movement of the shaft, ratchet, &c., the instant the forward movement of the pawl ceases. After the parts have been correctly adjusted nut 213 is locked in position by lock screw 215 which engages the end of said stud, the head of said screw engaging the outer face of the nut.

216, see Figs. 4 and 10, denotes masses of thick ink in boxes 217, having at their forward ends ink-supplying rollers 218 which are preferably corrugated. These rollers are carried by shafts 219 journaled in the sides of the boxes. Within the boxes are slides 220, the forward ends of which extend partly under rollers 218 and act to determine the quantity of ink that can be taken up by the ink supplying rollers the slides when moved up in contact with the rollers acting as scrapers and when moved back slightly permitting a limited quantity of ink to pass through the openings between the slides and the rollers and to be taken up by the rollers. At the rear ends of the boxes are blocks 222. The rear ends of the slides extend through these blocks and are engaged by screws 223 carrying disks 224, which engage recesses cut in the rear ends of the slides, see Figs. 10 and 11. The disks being rigidly secured to the screws it follows that when the screws are turned in or out in the blocks the engagement of the disks with the slides will move the latter in or out relatively to the ink supplying rollers thereby regulating the size of the openings and consequently the quantity of ink taken up by the rollers. Slides 220 are locked in position after adjustment by means of screws 327 which pass through slots, not shown, in the slides and engage blocks 222. In making an adjustment these screws are slightly loosened and are then tightened up again. The position of rollers 218 is changed axially at each backward movement of the boxes by the mechanism which I will now explain.

225, see Figs. 11 and 14, denotes ratchets on shafts 219, these ratchets as well as the rollers being rigidly fixed to the shafts.

226 denotes arms which swing on shafts 219 and carry pawls 227 which engage the ratchets, said pawls being held in engagement with the ratchets by springs 228. At the lower ends of arms 226 are rollers 229 which engage slots 230 in uprights 231 and 328 the bases of which are rigidly secured to the bed by screws 232, and 329.

233, see Figs. 4, 11 and 14, denotes shafts which are adapted to turn in swinging arms 226 and carry at their inner ends lugs 234 which are adapted to engage corresponding lugs 235 extending outward from the rear ends of pawls 227. Shafts 233 are provided

with thumb pieces 236 for convenience in operation.

237 denotes springs surrounding said shafts and bearing against collars 238 on said shafts and against bosses 239 on the swinging arms through which the shafts pass to give increased bearing. These springs are strong enough to draw lugs 234 tightly against the sides of the swinging arms and to hold said lugs in any position in which they may be placed.

As shown in Fig. 14 the lug 234 is out of operative position and consequently each time slide 137 moves forward as in Figs. 10 and 10<sup>a</sup> the swinging arms will be held backward through the engagement of rollers 229 with slots 230 and pawls 227 will each be dragged backward over a tooth of the corresponding ratchet. When the backward movement of slide 137 takes place, that is when the parts are moved from the position shown in Figs. 10 and 10<sup>a</sup> to the position shown in Fig. 12 the pawls will carry the ratchets forward one tooth and with them of course the shafts and ink supplying rollers 218.

Should it be preferred for any reason that roller 218 remain stationary while the machine is in use shaft 219 is turned until lug 234 engages lug 235 and throws the pawl out of engagement with the ratchet against the power of spring 228, spring 237 being strong enough to hold the parts in the position in which they are placed and to retain the pawl out of engagement against the power of spring 228.

The wads are expelled from the machine after being printed by means of a rod 240 which is carried by an arm 241 extending outward from carrier 87. At the lower end of rod 240 is a head having engaging points 221, see Fig. 3<sup>a</sup>, which engage the face of each wad near the edge so as to prevent the possibility of blurring the imprint before the ink is dry. At each movement of the carriers, types, &c., this head passes down through one of the holes in the dial and the points engage a wad and force it out from the dial, expelling it from the machine through hole 83 in the bed, ring 291 and casting 40, see Fig. 9, a suitable receptacle being placed under the bed to receive the printed wads. In order to prevent a solid blow being given by the expelling rod should any displacement or other accident happen to any of the parts of the machine, I provide a spring 242 which surrounds the rod, one end bearing against an adjustable collar 243, the other end bearing against the under side of an enlargement 244 at the outer end of the arm through which the rod passes. A collar 245 above the enlargement prevents the rod from dropping out. Should it be desired to lock the rod in a rigid position it may be done by tightening up set screw 246.

The operation of each mechanism in the machine has been so fully described in explaining the mechanism itself that detailed description of the operation of the entire ma-

chine is not thought to be necessary. It is sufficient to say in brief that a wad is fed to the dial at each actuation of the machine. The wads are carried around by the dial, one being printed on both sides at each actuation of the machine and a printed wad being expelled at each actuation of the machine. Each time the types move inward they are inked by rollers which pass across their faces, said rollers during the backward movement passing twice across the face of ink distributing tables which are themselves rotating in the horizontal plane. At a predetermined time, in the present instance at each eighteenth backward movement of the inking rollers, the ink supplying mechanism as a whole moves forward and meets the inking rollers, the inking rollers receiving ink from ink supplying rollers in the ink boxes which are given a slight axial movement each time they move backward so that at the next forward movement of the ink supplying rollers other portions of their surfaces will be presented to the inking rollers. The inking rollers after receiving ink from the ink supplying rollers pass over the ink distributing tables so that the ink is spread evenly upon the surface of the inking rollers and the greater portion of the ink received is left upon the ink distributing tables. Mechanism is provided for preventing the rotation of the ink supplying rollers if preferred so that but a small quantity of ink will be transferred from said rollers to the inking rollers.

Having thus described my invention, I claim—

1. The combination with a dial having holes to receive wads and a receiver by which the wads are delivered to the holes in the dial, of plungers carrying types by which each wad is printed on both sides and suitable means for limiting the inward movement of the plungers so that the types will not strike should there be no wad in the corresponding hole in the dial.

2. The combination with suitable wad feeding mechanism, of a dial having holes to receive wads, a casting 40 having a recess to receive the dial, and a ring 291 secured to the casting over whose surface the wads are carried by the dial and which is provided with an opening 83 which also extends through the casting by which the wads are expelled and reciprocating plungers carrying types by which the wads are printed on both sides simultaneously.

3. The combination with suitable wad feeding mechanism, casting 40 having a recess and a dial 35, the operative portion of which is made the exact thickness of the wads themselves, and which is provided with holes adapted to receive wads and to register with said recess, of upper and lower plungers, the latter lying in said recess which are adapted to register with the holes in the dial and to print the wads simultaneously on both sides.

4. The combination with suitable wad feed-

ing mechanism, and a casting 40 having a recess 39, of a ring 291 secured to the casting and provided with a hole 315, a dial journaled in the recess the operative portion of which extends over and rests upon the ring, is made the exact thickness of the wads themselves and is provided with holes to receive the wads and reciprocating plungers carrying types which register with hole 315 and print the wad therein on both sides.

5. The combination with suitable wad feeding mechanism, and a casting 40 having a recess 39, of a ring 291 secured to said casting and provided with a hole 315 and a curved groove 317, a dial journaled in said recess the operative portion of which extends over and rests upon the ring, is made the exact thickness of the wads themselves and is provided with holes to receive the wads, and plungers adapted to register with hole 315 by which the wad in said hole is printed on both sides simultaneously, said groove 317 being slightly wider than the width of the print so that as the wad is carried along by the dial over the surface of the ring opposite edges only of the wad will engage the ring, the printed portion of the under side being over the groove so that blurring of the print is prevented.

6. In a machine of the character described the combination with suitable wad feeding mechanism and reciprocating plungers carrying types by which the wads are printed on both sides simultaneously, of a ring 291 having a hole 315 with which the plungers register and a curved groove 317 extending therefrom and a dial having an operative portion which extends over and rests upon the ring, and is provided with holes which receive the wads from the feeding mechanism and carry them into position to be printed and then over the surface of the groove which is wider than the width of the print so that the edges only of the wad rest upon the ring and the print is not blurred.

7. In a machine of the character described the combination with suitable wad feeding mechanism and reciprocating plungers carrying types by which the wads are printed on both sides simultaneously, of a ring 291 having a hole 315 with which the plungers register, a hole 83 through which the wads are expelled and a curved groove 317 between said holes, a dial having an operative portion which extends over and rests upon the ring and is provided with holes which receive the wads from the feeding mechanism, carry them into position to be printed and then over the surface of the groove, to hole 83 and a reciprocating rod 240 by which the printed wads are expelled from the machine.

8. The combination with suitable wad feeding mechanism of a dial having holes to receive wads, a casting 40 having a recess to receive the dial, a ring 291 secured to the casting over whose surface the wads are carried by the dial and which is provided with a hole 315, reciprocating plungers carrying types

which are adapted to register with said hole and print the wad therein on both sides and an adjustable stripper plate 302 through which the upper plunger passes in the downward movement and which prevents the removal of the wad when the upward movement of the plunger takes place.

9. The combination with wad feeding mechanism, the dial having holes to receive wads, casting 40 having a recess to receive the dial and a ring 291 secured to the casting and having a hole 315, of the plungers carrying types which register with said hole and print the wad on both sides, a stripper plate 302 having a hole 307 through which the upper plunger passes, a bracket 303 by which said plate is carried, and bolt 308 and adjusting screws 310 and 312 by which the stripper plate is adjusted relatively to hole 315.

10. The combination with suitable wad feeding mechanism, a dial having holes to receive wads and plungers carrying types by which the wads are printed on both sides, of casting 40 having a recess 39 to receive the dial, a recess 332 to receive the lower plunger and a recess 331, and a ring 291 secured in said recess and having a hole 315 at which the wads are printed and a hole 83 through which they are expelled from the machine.

11. The combination with suitable wad feeding mechanism, a dial having holes to receive wads therefrom and reciprocating plungers by which the wads are printed on both sides, of inking rollers 122 and 318, ink supplying rollers 218, ink distributing tables 143 and 320, and casting 40 having a recess 333 to receive inking roller 318 and a recess 334 to receive table 320.

12. The combination with the dial, carriers 87 and plungers 85 carrying types by which the wads in the dial are printed, of blocks 274 and 277 on said plungers, and a stop plate 294 and a nut 273 which are engaged by said blocks to prevent contact of the types should there be no wad in the dial.

13. The combination with upper carrier 87 and upper plunger 85 carrying block 277, of stop plate 294, block 295 by which it is carried, and screw 297 whose head bears on the under side of block 295 whereby the stop plate is adjusted relatively to block 277.

14. The combination with upper carrier 87 and upper plunger 85 carrying block 277, of stop plate 294, block 295 carrying the stop plate and having a slot 301, standard 108 having a groove to receive block 295, screw 297 by which the block and stop plate are adjusted and bolt 300 which passes through the slot and locks block 295 in position.

15. The combination with the dial having holes to receive wads, ring 291 over which the wads are carried by the dial and which is provided with a hole 315 and plungers carrying dies or types which register with hole 315 and print the wads on both sides, of a wad receiver by which the wads are delivered to the holes in the dial and independent tubes

through which the wads pass to the wad receiver.

16. The combination with the dial having holes to receive wads, ring 291 over which the wads are carried by the dial and which is provided with a hole 315 and plungers carrying dies or types which register with hole 315 and print the wads on both sides, of a wad receiver by which the wads are delivered to the holes in the dial, independent tubes which engage the wad receiver and are provided with cut-offs to hold the wads in place and a weight for forcing the wads down when the cutoff is drawn out.

17. The combination with the dial having holes to receive wads, ring 291 over which the wads are carried by the dial and which is provided with a hole 315 and plungers carrying dies or types which register with hole 315 and print the wads on both sides, of the wad receiver, wad tube 29 and spring 68 by which the upper end of the wad tube is supported.

18. The combination with the dial having holes to receive wads, ring 291 over which the wads are carried by the dial and which is provided with a hole 315 and plungers carrying dies or types which register with hole 315 and print the wads on both sides, of the wad receiver, the wad tube, rod 71 carrying an arm and block, a spring 68 secured to said block and provided with curves which receive and hold the wad tube.

19. The combination with the dial having holes to receive wads, ring 291 over which the wads are carried by the dial and which is provided with a hole 315 and plungers carrying dies or types which register with hole 315 and print the wads on both sides, of the wad tube having a cutoff 30 and a wad receiver which receives the lower end of the tube and is provided with holes 49 and springs 68 which support the upper end of the tube.

20. The combination with the dial having holes to receive wads, ring 291 over which the wads are carried by the dial and which is provided with a hole 315 and plungers carrying dies or types which register with hole 315 and print the wads on both sides, of bracket 33 having external screw thread 50 and a nut 51 which engages the thread and rests upon the top of the bracket whereby the height of the wad receiver relatively to the dial is adjusted.

21. The combination with the dial having holes to receive wads, ring 291 over which the wads are carried by the dial and which is provided with a hole 315 and plungers carrying dies or types which register with hole 315 and print the wads on both sides, of the wad receiver having a nut 51, bracket 33 having a head 247 through which the wad receiver passes and upon which the nut rests, a slot in one side of the head, ears on opposite sides of the slot and a screw 250 provided with a head 251 said screw passing loosely through one of the ears and being threaded to engage the other ear whereby the wad receiver is locked in place.

22. The combination with casting 40 having opening 54, the dial having holes to receive wads, ring 291 having hole 315 and plungers carrying dies or types which register with hole 315 and print the wads on both sides, of the wad receiver, bracket 33 by which it is carried, stud 53 lying in opening 54 and carrying the bracket and suitable means for adjusting the stud and with it the bracket and wad receiver relatively to the dial and ring.

23. The combination with casting 40 having opening 54, the dial having holes to receive wads, ring 291 having hole 315 and plungers carrying dies or types which register with hole 315 and print the wads on both sides, of bracket 33, stud 53 lying in the opening and carrying the bracket and screw 60 in the casting which engages the stud for the purpose of adjustment.

24. The combination with the dial having holes to receive wads, ring 291 over which the wads are carried by the dial and which is provided with a hole 315 and plungers carrying dies or types which register with hole 315 and print the wads on both sides, of bracket 33 having an arm 66, stud 53 by which the bracket is carried, the wad receiver and wad tube, rod 71, spring 68 carried by said bracket, block 65 and a screw 64 in said block which engages arm 66 to determine the lateral adjustment of the wad receiver relatively to the dial.

25. The combination with movable casting 40 having a recess 39 the dial having holes to receive wads, drum 37 which carries the dial and ratchet 38 within said recess, of ring 291 over which the wads are carried and which is provided with a hole 315, plungers carrying dies or types which register with hole 315 and print the wads on both sides, a pawl operating in connection with the ratchet to impart intermittent rotary motion to the dial and block 76 and screw 77 for determining the inward movement of the casting as and for the purpose set forth.

26. The combination with the dial having holes to receive wads, ring 291 having hole 315 and the upper and lower plungers carrying dies or types by which the wad in said hole is printed on both sides, of movable casting 40 by which the dial is carried and which is provided with a recess 332 to receive the lower plunger and suitable means for limiting the inward movement of the casting so as to preserve the alignment of the dies and types with hole 315.

27. The combination with the dial having holes to receive wads and ratchet 38, ring 291 over which the wads are carried and which is provided with a hole 315 and plungers carrying dies or types which register with hole 315 and print the wads on both sides, of bell crank lever 79, and spring actuated pawl 78 which is carried by said lever and engages the ratchet whereby intermittent rotary motion is imparted to the dial.

28. The combination with the wad receiver,

casting 40 having a recess 39, ring 291 secured to said casting and having a hole 315, of a dial journaled in said recess the operative portion of which is made the exact thickness of the wads and provided with holes to receive wads from the wad receiver said operative portion extending over the ring so that the holes successively register with hole 315 and upper and lower plungers carrying dies or types which register with hole 315 and print the wad therein on both sides.

29. The combination with upper and lower plungers having dies or types at their inner ends, the wad receiver, casting 40 having a recess 39 and ring 291 secured to said casting and having a hole 315, of a dial in said recess the operative portion of which extends over and rests upon the ring and is provided with holes to receive wads and an adjustable stripper plate which registers with hole 315 as and for the purpose set forth.

30. The combination with the wad receiver, casting 40 having a recess 39 and a ring 291 having holes 315 and 83 and between said holes a curved groove 317, of a dial journaled within said recess and having an operative portion made the exact thickness of the wads and provided with holes to receive wads and extending over the ring, upper and lower plungers carrying dies or types which register with hole 315 and print the wad therein on both sides, the print made by the lower die or types being narrower than the groove so that as the wad is carried along by the dial the print is not blurred.

31. The combination with the wad receiver and ring 291 having holes 315 and 83 and between said holes a curved groove 317, of a dial having an operative portion which extends over the ring and is provided with holes to receive wads and upper and lower plungers carrying dies or types which register with hole 315 and print the wad therein on both sides after which the wads are carried over the groove by the dial and reciprocating rod 240 having engaging points 221 which register with hole 83 and expel the printed wads from the machine.

32. The combination with the movable casting 40, the dial, ratchet and ring 291 having hole 315, of the plungers having dies or types which register with hole 315 and print the wad on both sides, and the pawl and operating lever by which the dial is actuated, said pawl being detachable from the ratchet so as to permit movement of the casting and parts carried thereby toward or from the plungers.

33. The combination with suitable wad feeding mechanism, ring 291 having hole 315, and the dial having holes to receive wads, of upper and lower carriers having vertical recesses, sleeves 88 in said recesses externally screw threaded at their lower ends and internally screw threaded at their upper ends, plungers within said sleeves carrying dies or types which register with hole 315, nuts 91 and 92, washers within the sleeves, springs

between the plungers and washers and set screws passing through nuts 92 and engaging the washers by which the tension of the springs is adjusted.

34. The combination with suitable wad feeding mechanism, ring 291 having hole 315 and the dial having holes to receive wads, of upper and lower plungers carrying types registering with hole 315 by which the wads are printed on both sides, vertically movable carriers in which the plungers are socketed, and springs interposed between the plungers and carriers whereby a perfect print is insured and which will yield to prevent injury of the dies or types.

35. The combination with suitable wad feeding mechanism, casting 40, the dial having holes to receive wads, and ring 291 having holes 315 and 83, of plungers carrying dies or types which register with hole 315 and print the wads on both sides and a vertically movable expelling rod which registers with hole 83 so that at each actuation of the machine a wad is received from the feeding mechanism, a wad is printed on both sides, and a wad is expelled from the machine.

36. The combination with suitable wad feeding mechanism, casting 40, the dial having holes to receive wads, a ring 291 having holes 315 and 83, and mechanism for imparting intermittent rotary motion to the dial, of plungers carrying dies or types which register with hole 315 and print the wads on both sides and a vertically movable expelling rod by which the wads are expelled from the machine.

37. The combination with suitable wad feeding mechanism, an intermittently rotating dial having holes to receive wads and ring 291 having hole 315, of reciprocating plungers carrying dies or types which register with hole 315 and print the wads on both sides and a reciprocating slide 124 carrying inking rollers 122 and 318 which pass over the face of the dies or types while the latter are at the retracted position.

38. The combination with suitable wad feeding mechanism, an intermittently rotating dial having holes to receive wads and ring 291 having hole 315, of reciprocating plungers carrying dies or types which register with hole 315 and print the wads on both sides, a reciprocating slide 124 carrying inking rollers 122 and 318 which pass over the face of the dies or types while the latter are at the retracted position and ink distributing tables 143 and 320 over which the inking rollers pass at each backward movement.

39. The combination with suitable wad feeding mechanism, an intermittently rotating dial having holes to receive wads and ring 291 having hole 315, of reciprocating plungers carrying dies or types which register with hole 315 and print the wads on both sides, a reciprocating slide 124 carrying inking rollers which pass over the face of the dies or types while the latter are at the retracted position, a reciprocating slide 137 carrying ink

supplying rollers 218 and mechanism for reciprocating slide 137 once during a predetermined number of actuations of the machine as and for the purpose set forth.

5 40. The combination with wad feeding mechanism, an intermittently rotating dial having holes to receive wads, ring 291 having hole 315 and plungers carrying dies or types which register with said hole and print the  
10 wad therein, of inking rollers 122 and 318, ink supplying rollers 218, ink boxes 217 in which said rollers are journaled, slides 220 in said boxes which extend partly under the rollers and means for adjusting said slides to regulate the quantity of ink taken up by the  
15 rollers.

41. The combination with wad feeding mechanism, an intermittently rotating dial having holes to receive wads, ring 291 having  
20 hole 315 and plungers carrying dies or types which register with said hole and print the wad therein, of inking rollers 122 and 318, ink supplying rollers 218, ink boxes 217 in which said rollers are journaled, slides 220 in said  
25 boxes the forward ends of which extend partly under the rollers the rear ends extending through the boxes, and screws 223 engaging the boxes and carrying disks 224 which engage the slides whereby the latter may be adjusted to determine the quantity of ink to be  
30 taken up by the rollers.

42. The combination with wad feeding mechanism, an intermittently rotating dial having holes to receive wads, ring 291 having  
35 hole 315 and plungers carrying dies or types which register with said hole and print the wad therein, of slide 137, brackets 174, the ink boxes carried by said brackets, the inking rollers the ink supplying rollers, shafts 219  
40 journaled in said boxes and carrying said rollers, ratchets 225 lying outside of the boxes, swinging arms 226 carrying pawls engaging the ratchets and uprights 231 and 328 having slots engaged by said swinging arms so that  
45 each time the slide and parts carried thereby move forward the pawls will move backward over the ratchets and when the slide moves backward the ratchets will be carried forward by the pawls thereby imparting movement to  
50 the rollers.

43. The combination with wad feeding mechanism, an intermittently rotating dial having holes to receive wads, ring 291 having  
55 hole 315 and plungers carrying dies or types which register with said hole and print the wads on both sides, of ink supplying rollers the inking rollers by which the types are inked, slide 137, the ink boxes carried thereby, shafts 219 journaled in said boxes and carrying  
60 the ink supplying rollers, ratchets 225, swinging arms 226, spring controlled pawls carried by said arms and engaging the ratchets, rollers 229 and uprights 231 and 328 having slots 230 engaged by said rollers as and  
65 for the purpose set forth.

44. The combination with wad feeding

mechanism, an intermittently rotating dial having holes to receive wads, ring 291 having hole 315 and plungers carrying dies or types which register with said hole and print the  
70 wad therein, of the inking rollers, slide 137, block 173 extending outward therefrom, slides 175 in said block, brackets 174 extending from the slides and the ink boxes and ink supplying rollers carried thereby.

45. The combination with wad feeding mechanism, an intermittently rotating dial having holes to receive wads, ring 291 having  
80 hole 315 and plungers carrying dies or types which register with said hole and print the wad therein, of the inking rollers, slide 137, block 173 extending outward from said slide, the ink boxes and ink supplying rollers carried thereby and screws 177 engaging the block and carrying disks engaging slides 175  
85 whereby the latter and the parts carried thereby may be adjusted independently of each other.

46. The combination with wad feeding mechanism, an intermittently rotating dial  
90 having holes to receive wads, ring 291 having hole 315 and plungers carrying dies or types which register with said hole and print the wad therein, of slide 124 carrying inking rollers which engage the types at the retracted  
95 position, slide 137, brackets 174 secured thereto and ink boxes and ink supplying rollers carried by said brackets.

47. The combination with upper and lower plungers having dies or types at their inner  
100 ends and inking rollers carried by the reciprocating slide by which the dies or types are inked while at their retracted position, of the ink distributing tables, ratchets 148, vertical rock shaft 161, bracket 162 by which the rock  
105 shaft is carried, crank arms 159 on said rock shaft, pawls carried by said arms which engage the ratchets and suitable means for giving vertical adjustment to the crank arms.

48. The combination with wad feeding  
110 mechanism, a dial having holes to receive wads, ring 291 having hole 315 and upper and lower plungers carrying dies or types at their inner ends, of the inking rollers carried by a reciprocating slide by which the dies or types  
115 are inked while at their retracted position, ink distributing tables over the surface of which the inking rollers pass while at their retracted position and ink supplying rollers which supply ink to the inking rollers once  
120 during a predetermined number of actuations of the machine.

49. The combination with suitable wad feeding mechanism, and a dial having holes  
125 to receive wads, of a ring 291 over whose surface the wads are carried by the dial and which is provided with a hole 315 and a curved groove 317 leading therefrom and reciprocating plungers carrying dies or types which register with hole 315 and print the wads simul-  
130 taneously on both sides, the wads after the printing being carried along by the dial over

the groove the edges only of the wads resting on the ring so that the print made by the lower die is not blurred.

5 50. The combination with the dial and the plungers, of ring 291 having groove 317 and the stripper plate having a groove 337 as and for the purpose set forth.

10 51. The combination with suitable wad feeding mechanism and a dial having holes to receive wads, of a ring 291 over whose surface the wads are carried by the dial and which is provided with a hole 315 and a curved groove 317 leading therefrom, reciprocating plungers carrying dies or types which register  
15 with hole 315 and print the wads simultaneously on both sides and a stripper plate 302 having a hole 307 and a groove 337 corresponding with groove 317, the wads after the printing being carried along by the dial the  
20 edges only of the wads resting on the ring, the printed portions thereof being under groove 337 and over groove 317 so that blurring of the print on either side of the wad is prevented.

25 52. The combination with suitable wad feeding mechanism and a dial having holes to receive wads, of a ring over whose surface the wads are carried by the dial and which is provided with a hole 315, reciprocating  
30 plungers carrying dies or types which regis-

ter with hole 315 and print the wads on both sides and a stripper plate which prevents the removal of the wad by the upper plunger, said stripper plate having a hole through which the plunger passes and a groove 337 slightly  
35 wider than the printed portion of the wad so that as the latter is carried along by the dial the print cannot be blurred by the stripper plate.

53. The combination with the bed, bracket 40 303, and suitable means for adjusting said bracket longitudinally and transversely on the bed, of stripper plate 302 having a slotted attaching arm, screw 304 passing through the slot and screw 305 which passes through the  
45 stripper plate and bears upon the top of the bracket whereby vertical adjustment is imparted to the stripper plate.

54. The combination with suitable wad feeding mechanism and a dial having holes  
50 to receive wads, of upper and lower plungers carrying dies or types, ring 291 having a hole 315 and a groove 317 and stripper plate 302 having a groove 337.

In testimony whereof I affix my signature in  
55 presence of two witnesses.

CHARLES R. RICHARDS.

Witnesses:

A. M. WOOSTER,  
S. B. RICHARDSON.