



(12) **DEMANDE DE BREVET CANADIEN**  
**CANADIAN PATENT APPLICATION**

(13) **A1**

(22) Date de dépôt/Filing Date: 2020/06/22  
(41) Mise à la disp. pub./Open to Public Insp.: 2020/12/24  
(30) Priorités/Priorities: 2019/06/24 (US62/865,547);  
2019/10/31 (US16/670,246)

(51) Cl.Int./Int.Cl. *F15B 11/12* (2006.01)  
(71) Demandeur/Applicant:  
AIR POWER SYSTEMS CO., LLC, US  
(72) Inventeurs/Inventors:  
THOMPSON, KENNETH E., US;  
TIETZ, RYAN S., US;  
DANDAMUDI, VINAY, US  
(74) Agent: ROBIC

(54) Titre : ACTIONNEUR DE FLUIDE DE REGULATION A ACTION PROPORTIONNELLE  
(54) Title: PROPORTIONAL CONTROL FLUID ACTUATOR

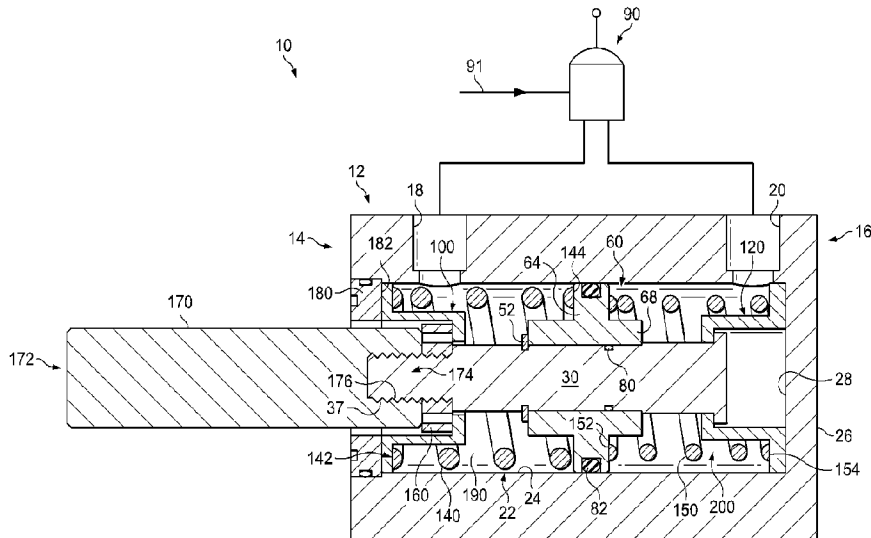

(57) **Abrégé/Abstract:**

A proportional control fluid actuator that is used as a positioning device in applications such as a hydraulic directional control valve. The activating device has a cylinder body attachable to a valve body and has a bore carrying a piston that is coaxially secured to an end of a valve spool. The device is provided with spaced openings in the cylinder body that communicate with the bore therein to introduce fluid to act on opposite sides of the piston. Factory pre-compressed spring means are provided for normally urging the piston and spool to a center position. Since the areas of the fluid pressure applied on both sides of the piston are different (due to a spool on one side of the piston), two pre-compressed springs are used to compensate the area difference to achieve a proportional movement of the spool.

**ABSTRACT**

A proportional control fluid actuator that is used as a positioning device in applications such as a hydraulic directional control valve. The activating device has a cylinder body attachable to a valve body and has a bore carrying a piston that is coaxially secured to an end of a valve spool. The device is provided with spaced openings in the cylinder body that communicate with the bore therein to introduce fluid to act on opposite sides of the piston. Factory pre-compressed spring means are provided for normally urging the piston and spool to a center position. Since the areas of the fluid pressure applied on both sides of the piston are different (due to a spool on one side of the piston), two pre-compressed springs are used to compensate the area difference to achieve a proportional movement of the spool.

**PROPORTIONAL CONTROL FLUID ACTUATOR**

**INVENTORS:**

Vinay Kumar Dandamudi, Kenneth E. Thompson, Ryan S. Tietz

**APPLICANT:**

Air Power Systems Co., LLC

**DOCKET NO.:**

013342-00012

**CROSS-REFERENCE TO CO-PENDING APPLICATIONS**

**[0001]** This application claims priority to U.S. Provisional Application No. 62/865,547, filed June 24, 2019, the entire application is incorporated herein by reference.

**FIELD OF THE DISCLOSURE**

**[0002]** The disclosure relates to a fluid powered actuator having a piston reciprocally positioned to move to three different positions. In particular, the present disclosure is directed to a fluid powered actuator which will reciprocate the piston proportionally to the applied fluid pressure.

**BACKGROUND**

**[0003]** Various types of fluid actuators are utilized for moving various types of machinery from one position to another position. These actuators utilize fluid to force a piston within a bore to move a shaft and may be either hydraulic or pneumatic. In one type of actuator, fluid pressure is directed to either side of the piston within a fluid tight cylinder to move the piston between positions. Three position actuators are known, such as Assignee's own actuator shown in U.S. Pat. No. 3,991,661.

**[0004]** Oftentimes, actuators are attached to the end of a hydraulic valve spool to raise or lower equipment such as a dump bed of a trailer or to extend or retract a hydraulic cylinder on various types of equipment. The actuator may be attached to the spool of the hydraulic valves. Therefore, an effective area in a fluid chamber on the spool side is less than an effective area in the opposite chamber by same amount as the area of the spool. As a result, response of the piston movement to the applied pressure is different in extend and retract directions.

#### SUMMARY

**[0005]** Embodiments of the present disclosure provide a fluid powered actuator that will respond proportionally to an applied fluid pressure. The fluid actuator includes a piston that is reciprocally positioned within a cylindrical chamber of a body of the actuator. The piston has a channel formed on its external circumferential surface. An O-ring or other seal mechanism resides in the channel to engage an interior wall of the cylindrical chamber and to form a fluid tight seal therewith. The piston includes an axial opening through which a piston shaft passes.

**[0006]** The piston shaft includes multiple steps, an O-ring groove, and a snap ring groove on its surface. The piston shaft passes through a flange bushing and piston while compressing a spring in between them. The piston is held on the piston shaft by the means of the snap ring. The piston shaft is passed through another flange bushing for compressing another spring in between the piston and second flange bushing. The second flange bushing is stopped at the end of the piston shaft. The force of the compression springs on the both sides of the piston will urge the piston to a center position.

**[0007]** The cylindrical chamber forms a fluid tight chamber that may be pressurized. Fluid to the cylindrical chamber is delivered by one of two fluid passageways, *i.e.*, a first fluid passageway and a second fluid passageway. Spring rates and initial compression of the springs are calculated based

on the area of the piston, the area of the spool and required working ranges of the fluid pressure. For purposes of this application, "neutral positioning force" is defined as a minimum force required to return the actuator to the neutral position and provide positive holding force to maintain the neutral position when no control fluid pressure is present. Actuator springs are pre-loaded to forces greater than or equal to the desired neutral positioning force. The design described has springs on opposing sides of the piston, but the springs are never at a condition of force equilibrium. The following calculations may be used to determine the required spring rate and initial compression:

**[0008]** Let the area of the piston be  $A_p$  and Area of the spool be  $A_s$ . Let the spring rate of a first spring in a first chamber be  $K_1$  and that of a second spring in a second chamber be  $K_2$ . Let the drag force due to the O-rings be  $F_d$ . Let the stroke of the actuator be  $S$ , fluid pressure in the first chamber is  $P_1$  and fluid pressure in the second chamber is  $P_2$ . Preload in the first spring be  $PL_1$  and preload in the second spring is  $PL_2$ .

**[0009]** The area of the fluid pressure application in the first chamber is  $A_1 = A_p$ .

**[0010]** The area of the fluid pressure application in the second chamber is  $A_2 = A_p - A_s$ .

**[0011]** The free body diagram of Figure 1 shows forces acting on a piston when starting pressure ( $P_{1s}$ ) is applied to chamber 1.

**[0012]** The free body diagram of Figure 2 shows forces acting on a piston when ending pressure ( $P_{1E}$ ) is applied to chamber 1.

**[0013]** The free body diagram of Figure 3 shows forces acting on a piston when starting pressure ( $P_{2s}$ ) is applied to chamber 2.

**[0014]** The free body diagram of Figure 4 shows forces acting on a piston when ending pressure ( $P_{2E}$ ) is applied to chamber 2.

[0015] From the above free body diagrams, we get the starting pressure  $P_{1S}$  and ending pressure  $P_{1E}$  when pressure is applied in the first chamber for a given stroke  $S$  are as follows.

$$[0016] P_{1S} = (PL_2 + F_d) / A_1;$$

$$[0017] P_{1E} = (PL_2 + F_d + K_2 S) / A_1;$$

[0018] From the above free body diagrams, we get the starting pressure  $P_{2S}$  and ending pressure  $P_{2E}$  when pressure is applied in the second chamber for a given stroke  $S$  as follows.

$$[0019] P_{2S} = (PL_1 + F_d) / A_2;$$

$$[0020] P_{2E} = (PL_1 + F_d + K_1 S) / A_2;$$

[0021] Since  $A_1 > A_2$ , the preloads and spring rates of the springs must be adjusted to make the actuator work in the required pressure ranges.

[0022] For purposes of this application, a "proportional positioning actuator" is an actuator wherein fluid pressure is applied to a double acting piston that generates a force acting against a spring, which results in a linear displacement that is proportional to the control fluid pressure.

[0023] The design described allows for wider control pressure range and greater ability to configure the minimum pressure at which the actuator begins to move from neutral and the pressure at which the actuator is at maximum displacement.

[0024] The actuator of the invention having a piston with only one response to the applied fluid pressure in either directions (extend or retract). This actuator can ensure more precise control of the equipment such as dump bed or hydraulic cylinder.

[0025] It is a further object and purpose of the present disclosure to provide a fluid actuator having a piston that can be held at a position in the range of its travel to ensure different flow rates in the hydraulic valves.

**[0026]** It is a further object and purpose of the present disclosure to provide a fluid actuator comprised of readily available components that is simple to assemble and install.

#### BRIEF DESCRIPTION OF THE DRAWINGS

**[0027]** Figure 1 is a free body diagram showing forces acting on a piston when a starting pressure is applied to a first chamber.

**[0028]** Figure 2 is a free body diagram showing forces acting on a piston when ending pressure is applied to the first chamber.

**[0029]** Figure 3 is a free body diagram showing forces acting on a piston when a starting pressure is applied to a second chamber.

**[0030]** Figure 4 is a free body diagram showing forces acting on a piston when an ending pressure is applied to the second chamber.

**[0031]** Figure 5 is a schematic and cutaway elevational view of an embodiment of the control fluid actuator of this disclosure in a neutral position.

**[0032]** Figure 6 is a schematic and cutaway elevational view of the control fluid actuator of FIG. 5 shown in an extended position.

**[0033]** Figure 7 is a schematic and cutaway elevational view of the control fluid actuator of FIG. 5 shown in a retracted position.

**[0034]** Figure 8 is a schematic view of internal components of the control fluid actuator of the of FIGS. 5-7.

DETAILED DESCRIPTION OF THE PREFERRED EMBODIMENTS

[0035] Referring now to Figures 5-7, shown is a position proportional control fluid actuator designated generally 10. Fluid actuator 10 includes body 12 defining a first end 14, a second end 16, a first fluid passageway 18, a second fluid passageway 20, and a bore 22. Bore 22 defines interior wall 24. Second end 16 has an end wall 26 defining an interior surface 28.

[0036] Piston shaft 30 is received in bore 22. Referring now primarily to Figure 8, piston shaft 30 has a first end 32 and a second end 34. Piston shaft 30 further defines a threaded portion 36 adjacent to first end 32, a central portion 38 having a larger diameter than threaded portion 36, and a third portion 40 defining a larger diameter than central portion 38. Threaded portion 36 defines external threads 37. Piston shaft 30 further defines lip 42 adjacent to second end 34. Lip 42 has a larger diameter than third portion 40. Piston shaft 30 defines first step 44 between threaded portion 36 and central portion 38. Piston shaft 30 also defines second step 46 between central portion 38 and third portion 40. Piston shaft 30 additionally defines third step 48 between third portion 40 and lip 42.

[0037] Piston shaft 30 defines snap ring groove 50 on central portion 38 between first step 44 and second step 46. Snap ring 52 (FIGS. 5-7) is located in snap ring groove 50.

[0038] Piston shaft 30 further defines O-ring groove 54 on central portion 38 between snap ring groove 50 and third step 48.

[0039] Piston member 60 has a piston cylinder 62 and piston disk 64. Piston cylinder 62 surrounds piston shaft 30. Piston cylinder 62 has first end 66, second end 68, and inside surface 70. Second end 68 abuts third step 48 of piston shaft 30. First end 66 is adjacent snap ring 52 for retaining piston cylinder 62 on piston shaft 30. Piston disk 64 is positioned between first fluid passageway 18 and second fluid passageway 20. Piston disk 64 has a first side 72, a second side 74, and an

external circumference defining channel **78**. O-ring **80** is located in O-ring groove **54** of piston shaft **30**. O-ring **80** is in sealing engagement with inside surface **70** of piston cylinder **62**. Seal **82** is located in channel **78** of piston disk **64**. Seal **82** is providing sealing engagement with interior wall **24** of bore **22**.

**[0040]** Fluid pressure supply switch **90** is provided for selectively routing fluid from forward pressure supply **91** to first fluid passageway **18** and second fluid passageway **20** for selectively moving piston member **60** longitudinally within bore **22** of body **12**.

**[0041]** A first flange bushing **100** defines an open end **102** and a closed end **104**. Closed end **104** defines first inside surface **106** and first orifice **108** for receiving third portion **38** of piston shaft **30**. Open end **102** defines first collar **110** having first end surface **112** and first spring receiving surface **114**.

**[0042]** Second flange bushing **120** defines open end **122** and closed end **124**. Closed end **124** defines second inside surface **126** and second orifice **128** for receiving central portion **40** of piston shaft **30**. Open end **122** defines a second collar **130** having a second end surface **132** and second spring receiving surface **134**.

**[0043]** Referring to Figures 5-7, first spring **140** has first end **142** and second end **144**. First end **142** abuts first spring receiving surface **114** of first flange bushing **100**. Second end **144** abuts first side **72** of piston disk **64**.

**[0044]** Second spring **150** has first end **152** and second end **154**. First end **152** abuts second side **74** of piston disk **64**. Second end **154** abuts second spring receiving surface **134** of second flange bushing **120**.

[0045] First securing nut **160** is received on threaded portion **36** of piston shaft **30**. First securing nut **160** abuts first step **44** and is adjacent to first inside surface **106** of closed end **104** of first flange bushing **100**.

[0046] Valve spool **170** has a first end **172** and a second end **174**. Second end **174** defines internal threads **176** for receiving threaded portion **36** of piston shaft **30**.

[0047] First seal ring **180** is adjacent first end **14** of body **12**. First seal ring **180** is received within bore **22** of body **12**. First seal ring **180** has inside surface **182**. Inside surface **182** is for limiting travel of first flange bushing **100** by abutting against first end surface **112** of first flange bushing **100** when first spring **140** is at maximum compression.

[0048] First chamber **190** is defined by inside surface **182** of first seal ring **180**, interior wall **24** of bore **22** and by first side **72** of piston disk **64**.

[0049] Second chamber **200** is defined by interior surface **28** of end wall **26** of second end **16** of body **12**, interior wall **24** of bore **22** and by second side **74** of piston disk **64**.

[0050] First area of pressure application **210** is defined by (Area of piston disk **64**) – (Area of the spool **170**) and is located within first chamber **190**.

[0051] Second area of pressure application **220** is defined by Area of piston disk **64** and is located within second chamber **200**.

[0052] First area of pressure application **210** in first chamber **190** is less than second area of pressure application **220** in second chamber **200**.

[0053] A preload and spring rate of first spring **140** is different than a preload and spring rate of second spring **150** for compensating for a difference between first area of pressure application **210** and second area of pressure application **220**.

\* \* \* \*

**[0054]** Embodiments of the present disclosure are well adapted to carry out the objectives and attain the ends and advantages mentioned above as well as those inherent therein. While presently preferred embodiments have been described for purposes of this disclosure, numerous changes and modifications will be apparent to those of ordinary skill in the art. Such changes and modifications are encompassed within the spirit of this disclosure as defined by the claims.

CLAIMS

1. An actuator comprising:
  - a body defining a bore;
  - a piston in said bore, said piston having a first side and a second side, said first side partially defining a first chamber in said bore, said second side partially defining a second chamber in said bore;
  - a first spring on said first side of said piston, said first spring having a first spring rate;
  - a second spring on said second side of said piston, said second spring having a second spring rate;
  - a fluid pressure supply switch for selectively routing fluid to one of said first chamber and said second chamber for moving said piston in a desired direction.
  
2. The actuator according to claim 1 wherein:
  - said first chamber defines a first area of pressure application;
  - said second chamber defines a second area of pressure application; and
  - wherein said first area of pressure application in said first chamber is greater than said second area of pressure application in said second chamber.
  
3. The actuator according to claim 2 further comprising:
  - wherein a preload and said first spring rate of said first spring is different than a preload and said second spring rate of said second spring for compensating for a difference between said first area of pressure application and said second area of pressure application.

4. A method of operating a proportion control fluid actuator comprising the steps of:
  - positioning a fluid pressure supply switch for routing pressurized fluid to one of a first chamber and a second chamber, said first chamber and said second chamber having a piston therebetween;
  - wherein a first area of pressure application is in said first chamber;
  - wherein when said pressurized fluid is routed to said first chamber, said piston moves in a second direction, wherein movement of said piston is resisted by a second spring having a second spring rate;
  - wherein a second area of pressure application is in said second chamber;
  - wherein said first area of pressure application in said first chamber is greater than said second area of pressure application in said second chamber;
  - wherein when said pressurized fluid is routed to said second chamber, said piston moves in a first direction, wherein movement of said piston is resisted by a first spring having a first spring rate.
  
5. The actuator according to claim 4 further comprising:
  - wherein a preload and said first spring rate of said first spring is different than a preload and said second spring rate of said second spring for compensating for a difference between said first area of pressure application and said second area of pressure application.

6. The method according to claim 4 wherein:

a starting pressure in said first chamber is equal to a sum of a preload of said second spring and the drag force of O-rings on said piston, said sum divided by said first area of pressure application in said first chamber.

7. The method according to claim 6 wherein:

said first area of pressure application in said first chamber is equal to an area of a first side of said piston.

8. The method according to claim 4 wherein:

an ending pressure in said first chamber is equal to sum of a preload of said second spring, a drag force of O-rings on said piston, said second spring rate of said second spring times a stroke length of said piston, said sum divided by said first area of pressure application in said first chamber.

9. The method according to claim 4 wherein:

a starting pressure in said second chamber is equal to a sum of a preload of said first spring and the drag force of O-rings on said piston, said sum divided by said first area of pressure application in said first chamber.

10. The method according to claim 4 wherein:

an ending pressure in said second chamber is equal to a sum of a preload of said first spring, a drag force of O-rings on said piston, said first spring rate of said first spring times a stroke length of said piston, said sum divided by said first area of pressure application in said first chamber.

11. The method according to claim 4 wherein:

said first area of pressure application in said first chamber is equal to an area of said piston minus an area of a spool.

12. A position proportional control fluid actuator comprising:

a body defining a first end, a second end, a first fluid passageway, a second fluid passageway, and a bore, said bore defining an interior wall, said second end having an end wall defining an interior surface;

a piston shaft received in said bore, said piston shaft having a first end and a second end;

a piston member having a piston cylinder and a piston disk, said piston cylinder surrounding said piston shaft, said piston cylinder having a first end, a second end and an inside surface, said second end abutting said second step of said piston shaft, said piston disk positioned between said first fluid passageway and said second fluid passageway, said piston disk having a first side, a second side and an external circumference defining a channel;

a fluid pressure supply switch for selectively providing fluid to said first fluid passageway and said second fluid passageway for selectively moving said piston member longitudinally within said bore of said body;

a first spring having a first end and a second end, said second end abutting said first side of said piston disk;

a second spring having a first end and a second end, said first end abutting said second side of said piston disk;

wherein a first chamber is adjacent said first side of said piston disk;

wherein said second chamber is adjacent said second side of said piston disk;

wherein a first area of pressure application is in said first chamber;

wherein a second area of pressure application is in said second chamber;

wherein said first area of pressure application in said first chamber is greater than said second area of pressure application in said second chamber.

13. The actuator according to claim 12 wherein:

said piston shaft further defining a threaded portion adjacent said first end, a central portion having a larger diameter than said threaded portion, a third portion defining a larger diameter than said central portion, and a lip adjacent said second end, said lip having a larger diameter than said third portion, said piston shaft defining a first step between said threaded portion and said central portion, said piston shaft defining a second step between said central portion and said third portion, said piston shaft defining a third step between said third portion and said lip.

14. The actuator according to claim 12 further comprising:
- said piston shaft defining a snap ring groove on said central portion between said first step and said second step;
  - a snap ring in said snap ring groove;
  - said piston shaft defining an O-ring groove on said central portion between said snap ring groove and said second step;
  - said first end of said piston cylinder adjacent said snap ring for retaining said piston cylinder on said piston shaft.
15. The actuator according to claim 12 further comprising:
- an O-ring located in said O-ring groove of said piston shaft, said O-ring for sealing engagement with said inside surface of said piston cylinder;
  - a seal located in said channel of said piston disk, said seal for providing sealing engagement with said interior wall of said bore.
16. The actuator according to claim 12 further comprising:
- a first flange bushing defining an open end and a closed end, said closed end defining a first inside surface and a first orifice for receiving said central portion of said piston shaft, said open end defining a first collar having a first end surface and a first spring receiving surface;
  - a second flange bushing defining an open end and a closed end, said closed end defining a second inside surface and second orifice for receiving said third portion of said piston shaft, said open end defining a second collar having a second end surface and a second spring receiving surface.

17. The actuator according to claim 16 further comprising:
- a first spring having a first end and a second end, said first end abutting said first spring receiving surface of said first flange bushing, said second end abutting said first side of said piston disk;
  - a second spring having a first end and a second end, said first end abutting said second spring receiving surface of said second flange bushing, said second end abutting said second side of said piston disk.
18. The actuator according to claim 12 further comprising:
- a first seal ring adjacent said first end of said body and received within said bore, said first seal ring having an inside surface, said inside surface for limiting travel of said first flange bushing by abutting against said first end surface of said first flange bushing when said first spring is at maximum compression.
19. The actuator according to claim 12 further comprising:
- a valve spool actuator having first end and a second end, said second end defining internal threads for engaging said external threads of said threaded portion of said piston shaft.
20. The actuator according to claim 12 further comprising:
- wherein a preload and spring rate of said first spring is different than a preload and spring rate of said second spring for compensating for a difference between said first area of pressure application and said second area of pressure application.

21. The actuator according to claim 12 wherein:

said first chamber is defined by said inside surface of said first seal ring, said interior wall of said bore, and by said first side of said piston disk; and

said second chamber is defined by said interior surface of said end wall of said second end of said body, said interior wall of said bore and by said second side of said piston disk.

22. The actuator according to claim 12 wherein:

wherein a first area of pressure application is an area of said first side of said piston;

wherein a second area of pressure application is an area of said second side of said piston minus an area of said spool.

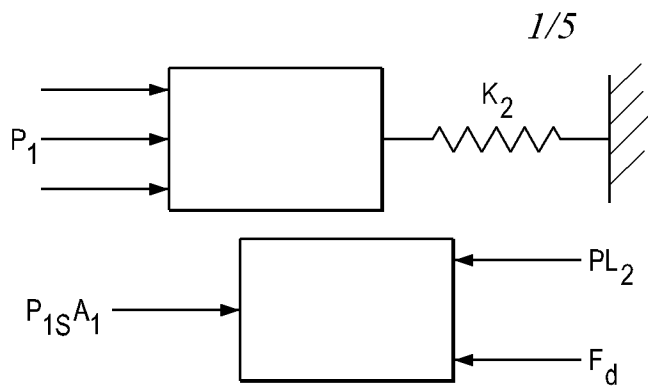

FIG. 1

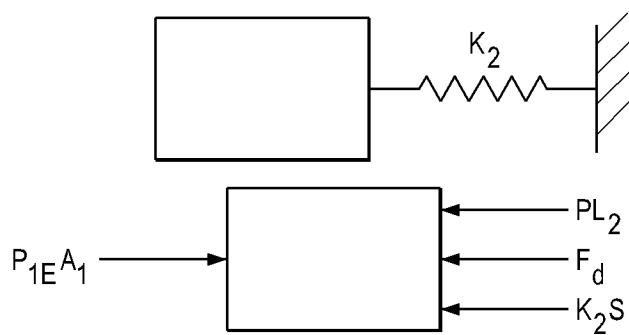

FIG. 2

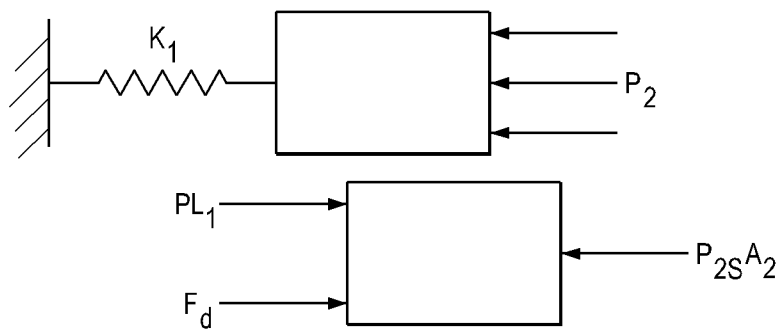

FIG. 3

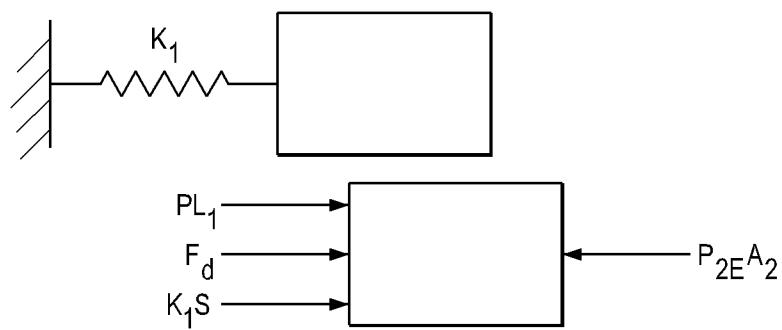

FIG. 4

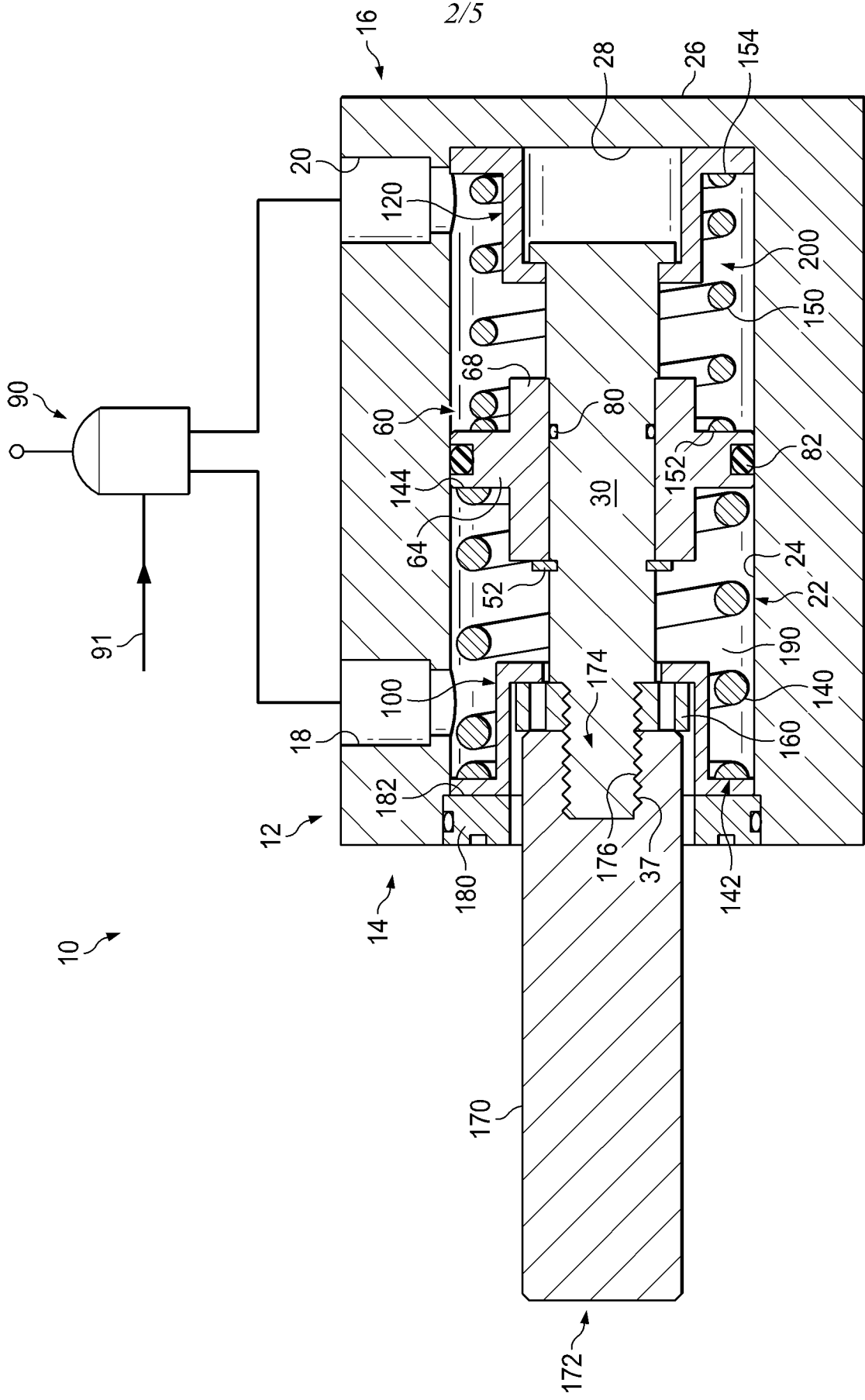

FIG. 5

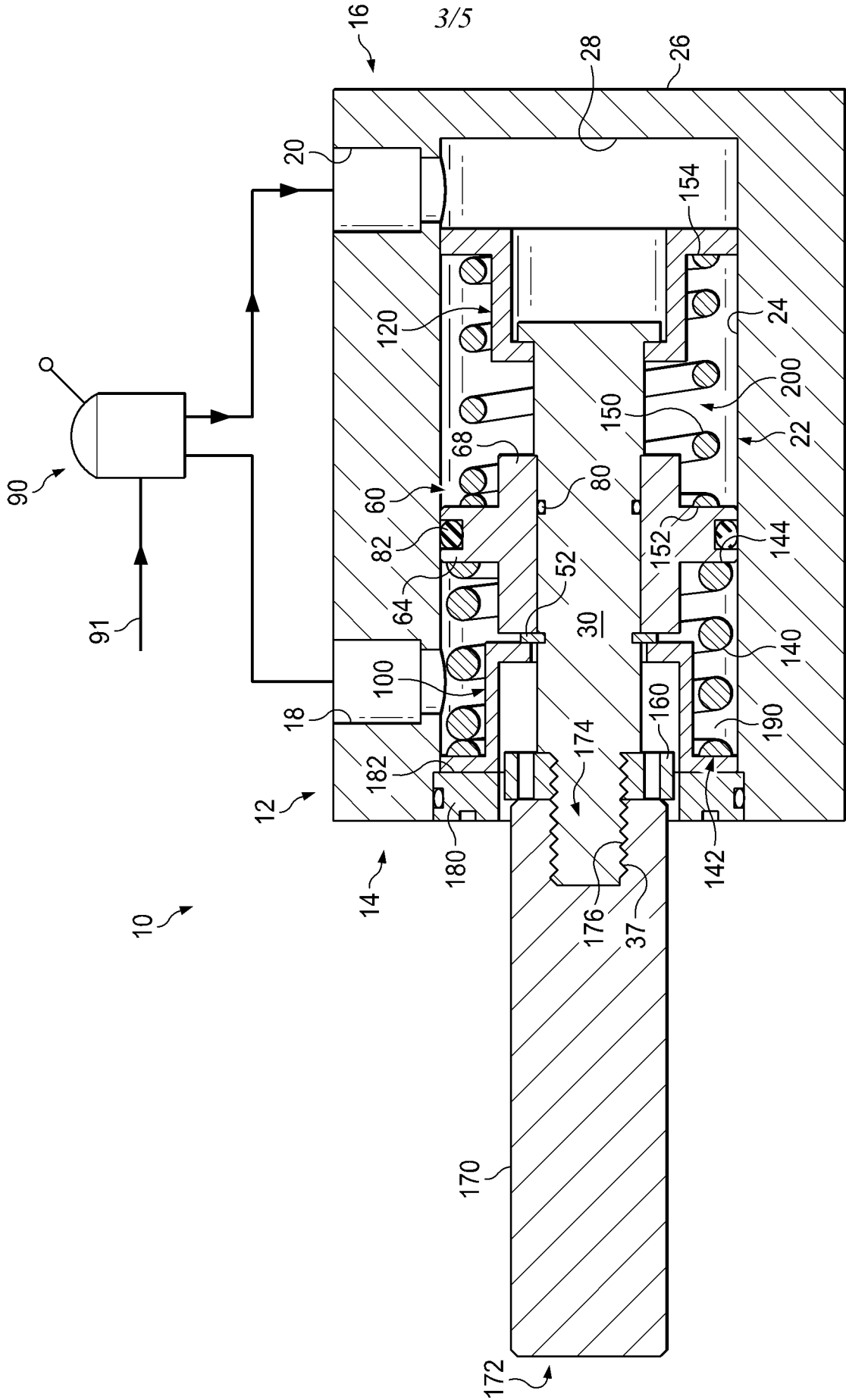

FIG. 6

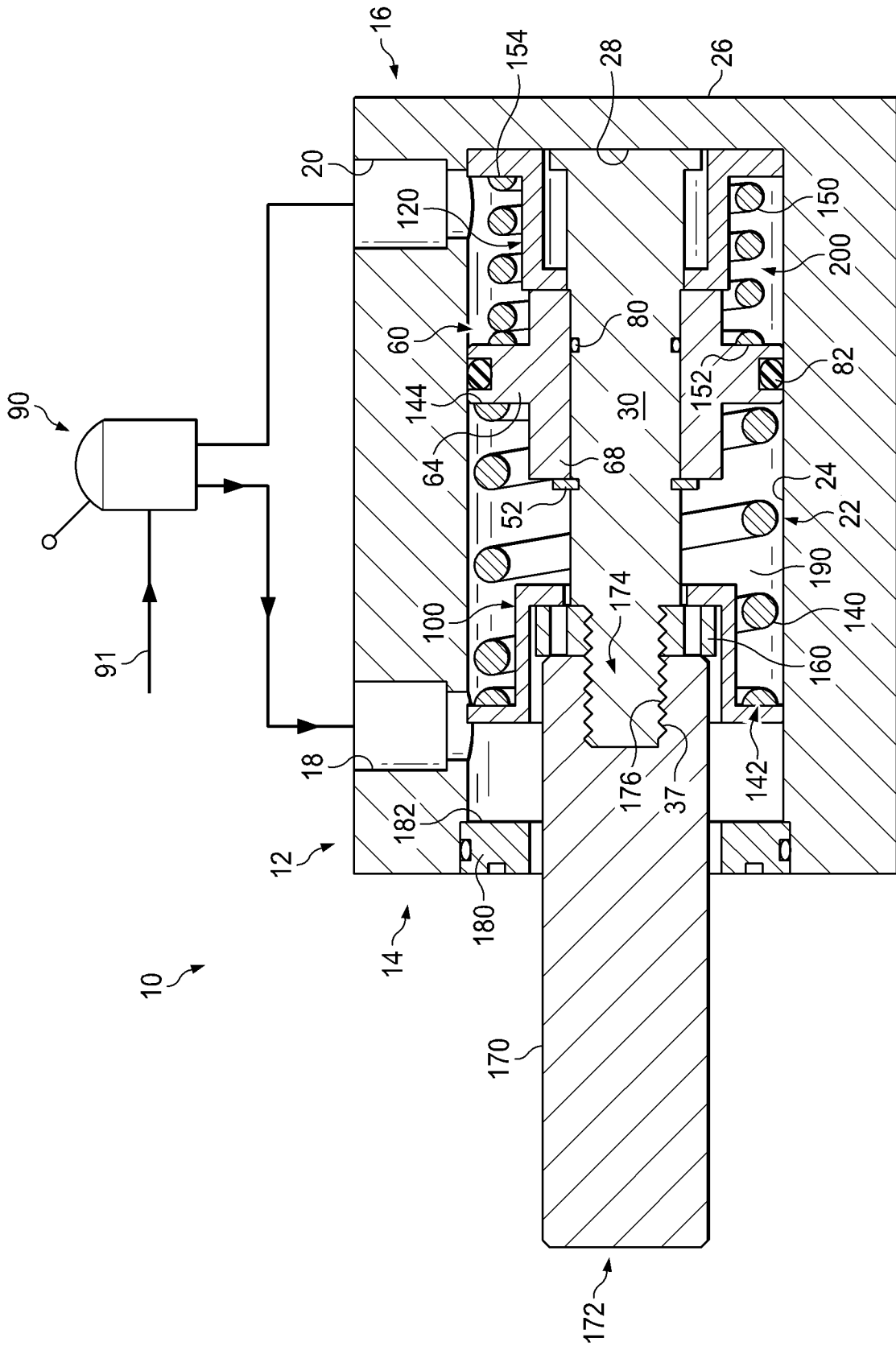

FIG. 7

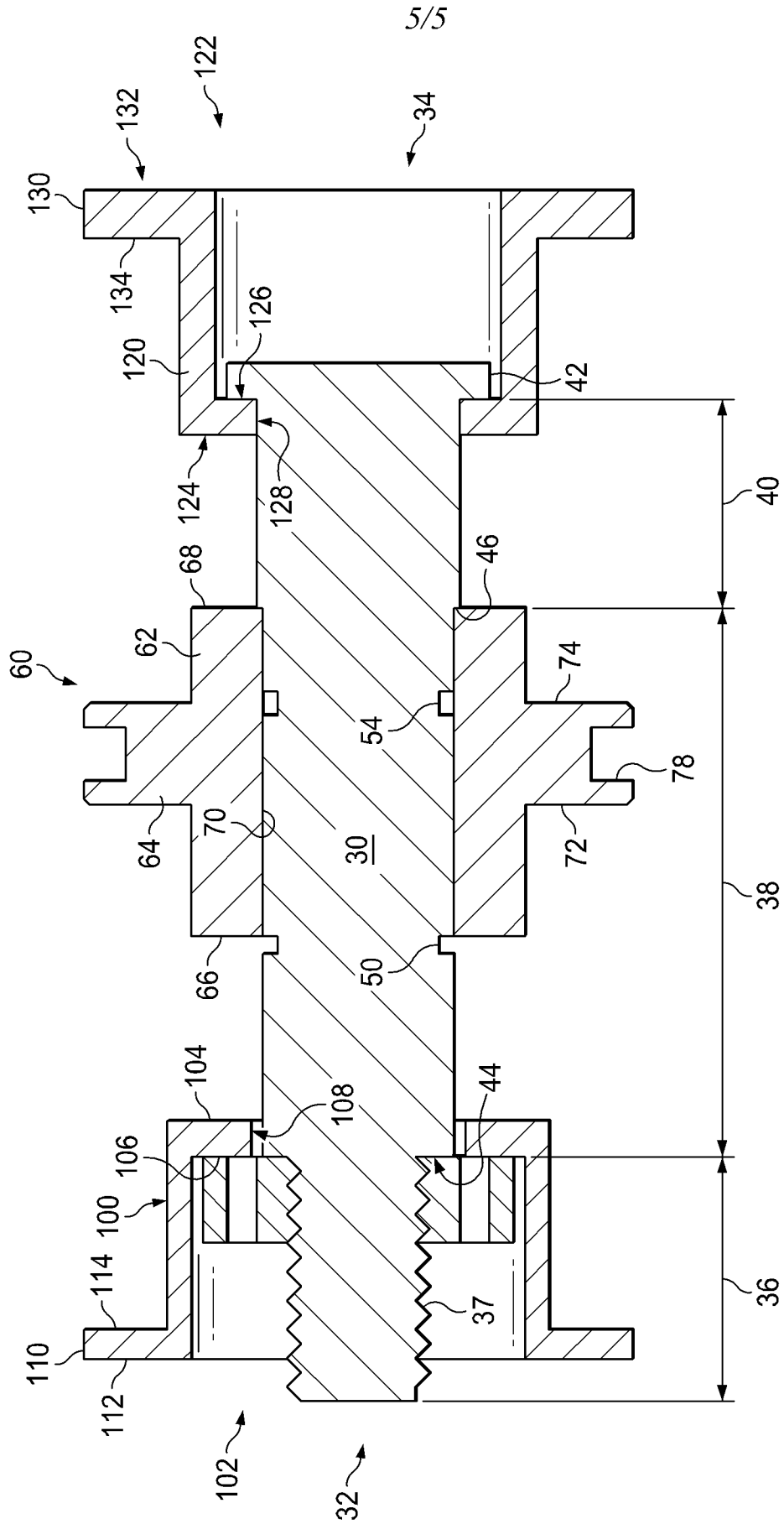

FIG. 8

