

948,677.

G. S. WILLIAMSON.  
MATRIX FORMING MACHINE.  
APPLICATION FILED OCT. 10, 1907.

Patented Feb. 8, 1910.

2 SHEETS—SHEET 1.

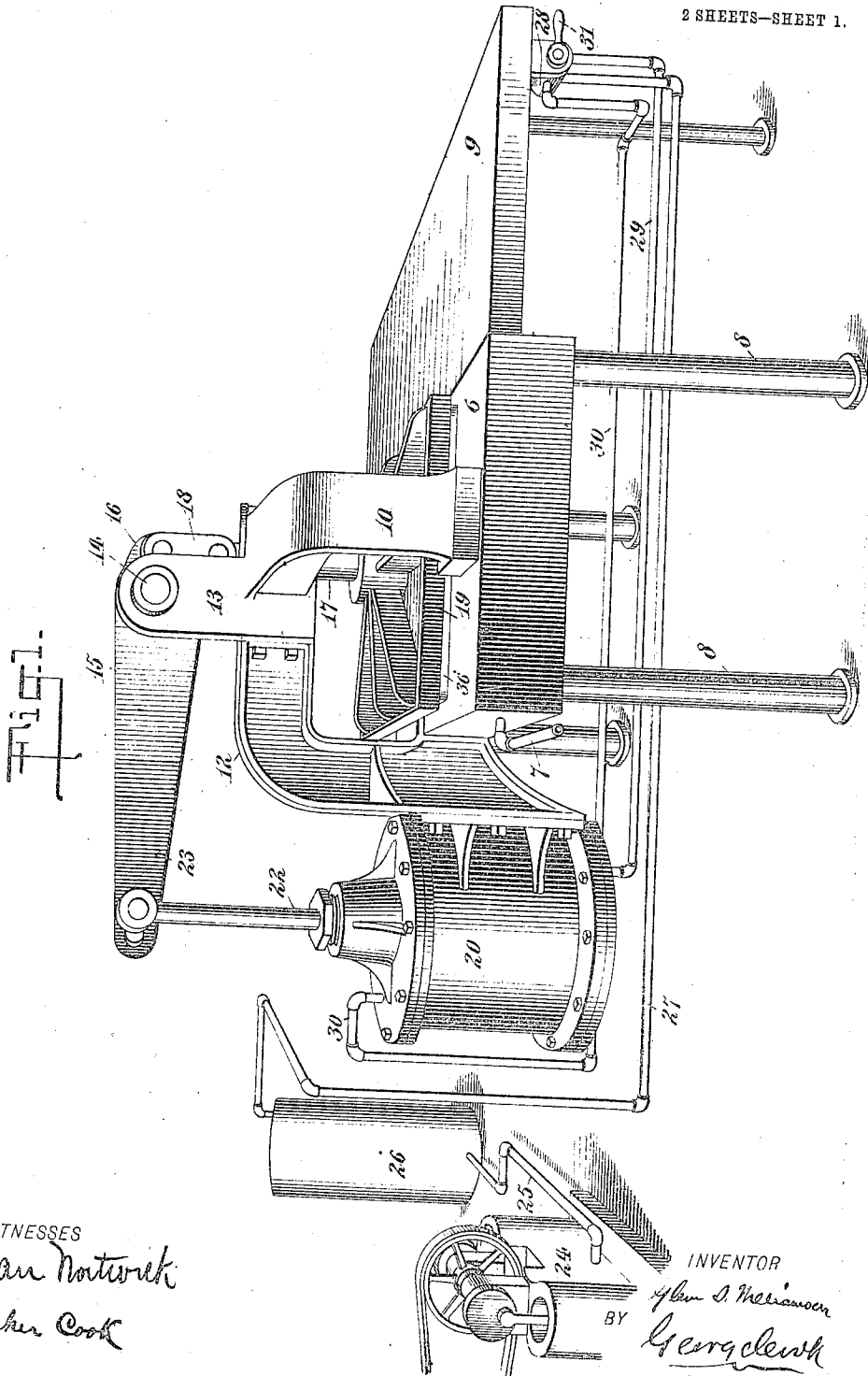

WITNESSES  
*M. Van Natterck*  
*Parker Cook*

INVENTOR  
*G. S. Williamson*  
BY  
*George Clark*  
ATTORNEY

948,677.

Patented Feb. 8, 1910.

2 SHEETS—SHEET 2.

Fig. 2.

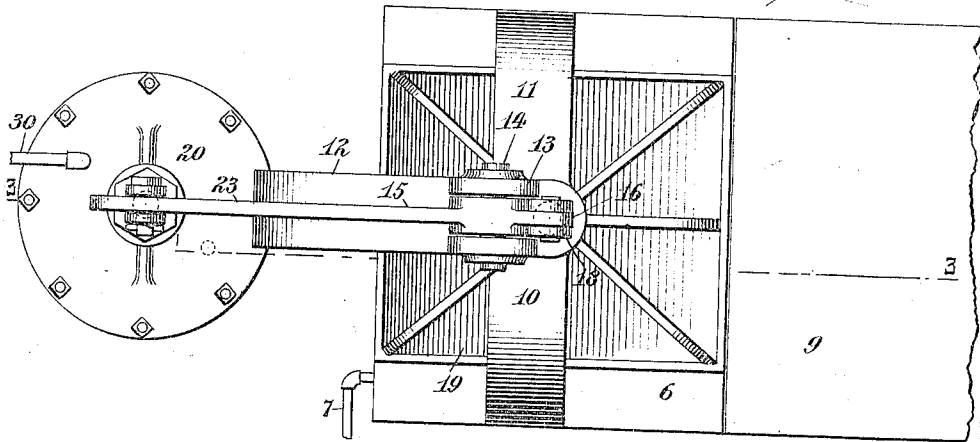

Fig. 3.

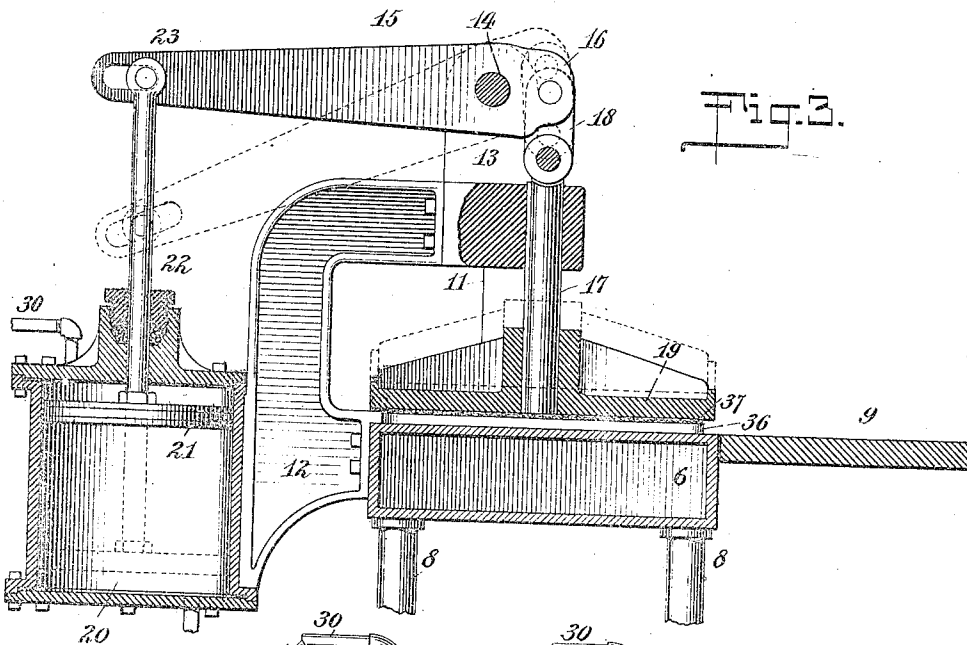

Fig. 4.

WITNESSES  
*M. Van Nortwick*  
*Parker Cook*

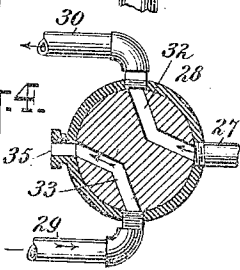
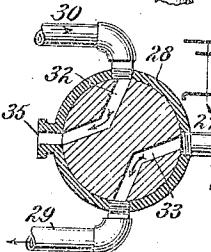

Fig. 5.



INVENTOR  
*G. S. Williamson*  
BY  
*Esery Clark*  
ATTORNEY

# UNITED STATES PATENT OFFICE.

GLENN S. WILLIAMSON, OF NEW YORK, N. Y., ASSIGNOR TO F. WESEL MANUFACTURING COMPANY, OF BROOKLYN, NEW YORK, A CORPORATION OF NEW YORK.

## MATRIX-FORMING MACHINE.

948,677.

Specification of Letters Patent.

Patented Feb. 8, 1910.

Application filed October 10, 1907. Serial No. 396,728.

*To all whom it may concern:*

Be it known that I, GLENN S. WILLIAMSON, a citizen of the United States, and a resident of New York, borough of Manhattan, in the county of New York and State of New York, have made and invented certain new and useful Improvements in Matrix-Forming Machines, of which the following is a specification.

My invention relates to machines to be employed in the art of printing, and more particularly to a machine designed for the making of a matrix from which to cast a stereotype plate for employment in a printing press.

Heretofore it has been customary to employ a device constructed much after the plan of a copying or letter press, the necessary pressure being imparted to the platen by the manual turning of a wheel attached to the upper end of a screw, the lower end being attached to the platen. This method, however, has proved objectionable by reason of the amount of labor and time consumed in practicing the same, requiring as it does several minutes to apply the pressure to the matrix and form, and subsequently releasing the same by the reverse operation. It has also been attempted, but with unsatisfactory results, to employ a device wherein a cylinder was located immediately above and over the platen, a piston rod being secured at one end to the piston contained within the cylinder and at the opposite end to the platen, the pressure from the cylinder being applied in suchwise directly to the platen. The failure in this instance, however, has been due to the fact that sufficient pressure could not be obtained or exerted upon the platen excepting by the use of a very large and cumbersome cylinder.

The object of my invention is to overcome the objections above noted, and to provide a device which will be simple and compact in construction, easily and readily operated, which will be effective in use, and by means of which a great saving of time and labor will be effected.

With these and other ends in view, I have designed my improved forming machine to be operated by pneumatic pressure, a small air compressor, tank and cylinder being located in the rear of the matrix table and operated from the front of the latter, the piston rod being connected at one end to the

piston in the cylinder, and at the opposite end to the end of the long arm of a lever, the shorter arm of the latter being linked to the upper end of the rod secured to the platen, the result being that by so multiplying the leverage, the necessary pressure can be imposed upon the platen to quickly and properly form the matrix.

The device further consists in certain novel features of construction and combinations of parts, as will be hereinafter fully described and pointed out in the claims.

In the accompanying drawings, Figure 1 is a view in perspective of my improved device. Fig. 2 is a plan view thereof, the air compressor and tank being omitted. Fig. 3 is a sectional view taken on the line 3-3 of Fig. 2. Figs. 4 and 5 are sectional views of the three-way valve in its different positions.

Referring to the drawings, 6 represents a hollow table to be supplied by steam from any suitable source through the inlet pipe 7, said table being supported on the legs or standards 8 and in front of which is located an apron table 9. To the steam table 6 is secured a frame consisting of the three legs or brackets 10, 11, 12, the two former extending lengthwise across the table, and the latter bracket 12 extending rearwardly for the purpose hereinafter indicated. From the bracket 10-11 extends upwardly the post or support 13, to which is fulcrumed at 14 the lever 15, the short arm 16 of which is connected to the upper end of the post 17 by means of the link 18, the lower end of said post being secured to the platen 19 located over the steam table 6.

To the bracket 12 is secured the cylinder 20 having contained therein the piston 21 to which latter is secured the lower end of the piston rod 22, the upper end being connected with the longer arm 23 of the lever 15. The respective lengths of the two arms 16 and 23 of the lever 15, will of course depend upon the amount of pressure to be exerted by the platen upon the matrix, those which I have used with good results being as 28 to 4.

At some convenient place, preferably to the rear of the device, is located an air compressor 24, from which leads a pipe 25 to a tank or reservoir 26, also located in some convenient place, and from which tank leads the outlet pipe 27 to a three-way valve 28 preferably supported below the forward end

or edge of the supporting or apron table 9. From this valve 28 also leads the pipe 29 to the lower end of the cylinder 20, that is, below the piston 21, and from the upper portion of the cylinder, that is, above the piston 21, leads the pipe 30 to the three-way valve 28, said valve being provided with a handle or lever 31. As shown in Figs. 4 and 5, this valve is provided with the two passages 32—33, the valve casing 34 being provided with an outlet or exhaust 35.

When it is desired to form the matrix, the type form 36 with the paper 37, or other material from which it is desired to form the matrix, is placed upon the steam table 6 and below the platen 19. The handle or lever 31 is then so turned as to allow the air contained within the tank or reservoir 26 to flow through the pipe 27, three-way valve 28, through the passage 33, through the pipe 29 into the cylinder 20 below the piston 21, the result being that the latter is forced upwardly, and by means of the lever 15 and rod 17, the platen 19 is lowered, the pressure thereof on the paper and type form being continued until the matrix is properly formed and dried.

In those machines which I have practically used with good results, it has been usual to maintain an air pressure in the tank or reservoir 26, say from 45 to 75 lbs., a reducing valve being employed in the piping connecting said tank or reservoir with the cylinder, in order that the pressure of air flowing from said tank to the cylinder shall be reduced to about 45 pounds and there maintained during the operation of the machine, the corresponding pressure exerted upon the platen by reason of the multiplication of leverage being from about 75,000 to 100,000 pounds.

The time required in the formation of the matrix, that is, the time required to properly impress and dry the material, depends, of course, somewhat upon the pressure exerted thereon, that required in the machines which I have used in practice being from two to three minutes.

After the matrix has been properly formed and dried, the lever or handle 31, which it will be noticed, is within convenient reach of the operator, is turned in the opposite direction, whereby the air passages 32—33 in the three-way valve will be shifted from the positions as illustrated in Fig. 5 to those illustrated in Fig. 4, permitting the air in the cylinder 20 and below the piston 21 to flow through the pipe 29, passage 33, and out of the exhaust 35, and the air to flow out of the tank 26, through the pipe 27, passage 32 and pipe 30 into the top of the cylinder 20 above the piston 21, thereby causing the latter to be forced downwardly and the platen 19 upwardly, whereupon the type form 36 with the finished matrix 37, may be

removed from the machine, the several parts of the latter occupying their normal positions, as illustrated in Fig. 1, and in dotted lines Fig. 3.

From the foregoing it will be understood that my invention is exceedingly simple in construction, and may be easily and readily operated with unskilled labor; that it is very effective in operation, and can be employed in the formation of a matrix either with or without first passing the type form and matrix blank under the usual forming or compressing roll, the device being capable of exerting any desired amount of pressure by varying or altering the lengths of the longer or shorter arms of the lever 15, or by raising or lowering the air pressure in the tank 26. Furthermore, by its use, I have found in practice that the time required in the formation of the matrix may be reduced from one-half to two-thirds, and entirely eliminating the hand labor required in the use of the old screw press.

It will of course be understood that several changes may be made in the detail construction and arrangement of the several parts from those shown and described, without departing from the spirit and scope of my invention, as for instance, the location of the air compressor, tank and cylinders, the piping, etc. Again, it will be understood without illustration that instead of returning the parts to their normal positions by means of air pressure over and upon the piston 21, a spring may be employed, and hence I do not limit the scope of my invention to such details, but:—

Having fully described my invention, what I claim as new and desire to secure by Letters Patent, is:—

1. An improved matrix-forming machine having in combination a table, a platen vertically disposed thereover, a frame secured to the table and consisting of three brackets, two of which extend lengthwise across the table while the third extends rearwardly at substantially right-angles with the other brackets having a portion disposed parallel with the edge of the table, a post or support extending upwardly from the first-named brackets, a lever fulcrumed between its ends to said post, a link carried by a short arm of the lever and connected to the platen, a fluid-pressure cylinder secured to the third-named bracket, a piston operable in the cylinder having a rod connected with a long arm of the lever, and means for controlling the admission of fluid-pressure to the cylinder.

2. In an apparatus for producing stereotype matrices, the combination of a table, a platen vertically disposed thereover, a frame secured to the table and consisting of three upwardly extending members, two of which extend lengthwise across the table

while the third extends rearwardly at substantially right angles with the others, a post or support extending upwardly from said frame, a lever fulcrumed between its ends to said post, a link carried by a short arm of the lever and connected to the platen, a fluid-pressure cylinder secured to the rearwardly extending member, a piston operable in the cylinder having a rod connected with a long arm of the lever, and means for controlling the admission of fluid-pressure to the cylinder.

3. In an apparatus for producing stereo-type matrices, the combination of a table, a vertically-operable platen having an upwardly extending stem, an arched frame fixed to the table and extending transversely across the same, said frame having a post extending vertically above its upper end and the central portion of said frame having a part extending horizontally in front of said post and provided with a vertical

guide and bearing for the upper end of the stem of the platen, a lever fulcrumed between its ends to said post so as to form a long and short arm; a link disposed substantially vertically in line with the stem of the platen having one end secured thereto and the other end secured to the short arm of the lever; a fluid-pressure cylinder and connections between the same and the long arm of the lever; circulating pipes for the cylinder, and means located at a distant point for controlling the fluid supply to the cylinder.

Signed at New York, borough of Manhattan, in the county of New York, and State of New York, this 9th day of October, A. D. 1907.

GLENN S. WILLIAMSON.

Witnesses:

M. VAN NORTWICK,  
PARKER COOK.