

(19) World Intellectual Property Organization  
International Bureau



(43) International Publication Date  
29 April 2010 (29.04.2010)

(10) International Publication Number  
**WO 2010/046202 A1**

(51) International Patent Classification:  
*H04L 5/00* (2006.01)

(21) International Application Number:  
PCT/EP2009/062571

(22) International Filing Date:  
29 September 2009 (29.09.2009)

(25) Filing Language: English

(26) Publication Language: English

(30) Priority Data:  
61/106,958 20 October 2008 (20.10.2008) US

(71) Applicant (for all designated States except US): **NOKIA SIEMENS NETWORKS OY** [FI/FI]; Karaportti 3, FI-02610 Espoo (FI).

(72) Inventors; and

(75) Inventors/Applicants (for US only): **CHUN, Joon Hwa** [KR/US]; 6229 Love Dr. Apt#427, Irving, TX, 75039 (US). **KANG, Jian Feng** [CN/CN]; Building No. 13, room 1-201, Yue Fu Jiang Nan, Yong Ding Lu B1, Hai

Dian district, Beijing, P.R.C. 100039 (CN). **LI, Shaohua** [CN/CN]; Lingxiu xinguigu, xi er qi, Haidian district, Beijing (CN). **LI, Zexian** [CN/FI]; Finnontie 52 D 11, FI-02280 Espoo (FI). **MALKOV, Andrei** [RU/FI]; Heikintie 8, FI-25130 Muurla (FI). **QI, Xin** [CN/CN]; Jasmin Garden, 5#2-801, Xibeiwang, Dezhenglu, Haidian District, Beijing, 100094 (CN). **WANG, Shu Shaw** [US/US]; 1803 Longbranch Ct., Arlington, TX, 76012 (US).

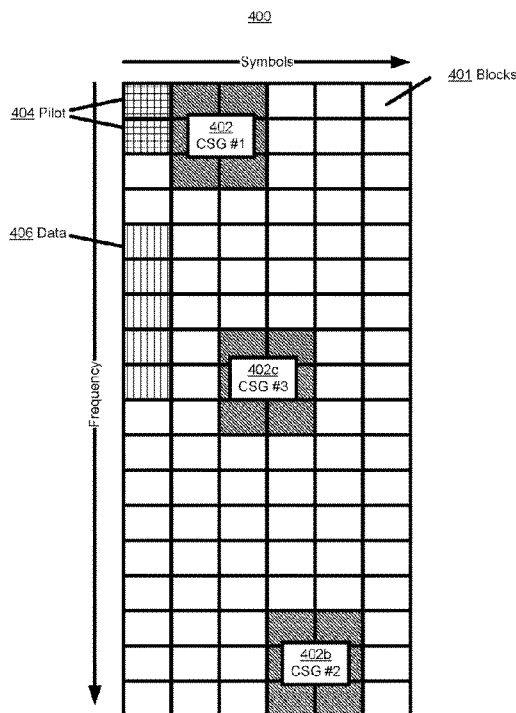
(74) Common Representative: **NOKIA SIEMENS NETWORKS OY**; COO RTP IPR/Patent Administration, 80240 Munich (DE).

(81) Designated States (unless otherwise indicated, for every kind of national protection available): AE, AG, AL, AM, AO, AT, AU, AZ, BA, BB, BG, BH, BR, BW, BY, BZ, CA, CH, CL, CN, CO, CR, CU, CZ, DE, DK, DM, DO, DZ, EC, EE, EG, ES, FI, GB, GD, GE, GH, GM, GT, HN, HR, HU, ID, IL, IN, IS, JP, KE, KG, KM, KN, KP, KR, KZ, LA, LC, LK, LR, LS, LT, LU, LY, MA, MD, ME, MG, MK, MN, MW, MX, MY, MZ, NA, NG, NI, NO, NZ, OM, PE, PG, PH, PL, PT, RO, RS, RU, SC, SD,

[Continued on next page]

(54) Title: SOUNDING CHANNEL APPARATUS AND METHOD

**FIG. 4**



(57) Abstract: Sounding Channel Apparatus and Method. According to an example embodiment, a method may include allocating, within a single physical resource unit (PRU), a plurality of channel sounding groups. Wherein each channel sounding group includes a frequency-time domain code division multiplexing (CDM) allocation. The method may also include broadcasting, in a downlink direction to one or more mobile stations in a wireless network, a signal that causes the receiving mobile stations to transmit a channel sounding signal. The method may further include receiving at least one channel sounding signal from at least one of the one or more mobile stations, the channel sounding signal being received in an uplink direction via one or more channel sounding groups. And, the method may include estimating the channel quality, of the channel used by the physical resource unit, based upon the received at least one channel sounding signal.

WO 2010/046202 A1



SE, SG, SK, SL, SM, ST, SV, SY, TJ, TM, TN, TR, TT, TZ, UA, UG, US, UZ, VC, VN, ZA, ZM, ZW.

ES, FI, FR, GB, GR, HR, HU, IE, IS, IT, LT, LU, LV, MC, MK, MT, NL, NO, PL, PT, RO, SE, SI, SK, SM, TR), OAPI (BF, BJ, CF, CG, CI, CM, GA, GN, GQ, GW, ML, MR, NE, SN, TD, TG).

**(84) Designated States** (*unless otherwise indicated, for every kind of regional protection available*): ARIPO (BW, GH, GM, KE, LS, MW, MZ, NA, SD, SL, SZ, TZ, UG, ZM, ZW), Eurasian (AM, AZ, BY, KG, KZ, MD, RU, TJ, TM), European (AT, BE, BG, CH, CY, CZ, DE, DK, EE,

**Published:**

— *with international search report (Art. 21(3))*

**DESCRIPTION****TITLE**

5                   **Sounding Channel Apparatus and Method**

**TECHNICAL FIELD**

10           **[0001]**       This description relates to communications, and more specifically to the feedback of communication channel condition information and the allocation of resources based, in part, upon the information feedback.

**BACKGROUND**

15           **[0002]**       Worldwide Interoperability for Microwave Access (WiMAX) is a telecommunications technology often aimed at providing wireless data over long distances (e.g., kilometers) in a variety of ways, from point-to-point links to full mobile cellular type access. A network based upon WiMAX is occasionally also called a Wireless Metropolitan Access Network (WirelessMAN or WMAN); although, it is understood that WMANs may include protocols other than WiMAX. WiMAX often  
20 includes a network that is substantially in compliance with the IEEE 802.16 standards, their derivatives, or predecessors (hereafter, "the 802.16 standard"). Institute of Electrical and Electronics Engineers, *IEEE Standard for Local and Metropolitan Area Networks, Part 16*, IEEE Std. 802.16-2004.

25           **[0003]**       One particular derivative of the 802.16 standard is the 802.16m standard that attempts to increase the data rate of wireless transmissions to 1 Gbps while maintaining backwards compatibility with older networks. IEEE 802.16 Broadband Wireless Access Working Group, *IEEE 802.16m System Requirements*, Oct. 19, 2007.  
30

**[0004]**       Wireless Local Area Network (WLAN) is a telecommu-

nications technology often aimed at providing wireless data over shorter distances (e.g., meters or tens of meters) in a variety of ways, from point-to-point links to full mobile cellular type access. A network based upon the WLAN standard is occasionally also referred to by the common or marketing name "WiFi" (or "Wi-Fi") from Wireless Fidelity; although it is understood that WLAN may include other shorter ranged technologies. WiFi often includes a network that is substantially in compliance with the IEEE 802.11 standards, their derivatives, or predecessors (hereafter, "the 802.11 standard"). Institute of Electrical and Electronics Engineers, *IEEE Standard for Information Technology -- Telecommunications and Information Exchange between Systems -- Local and Metropolitan Area Network -- Specific Requirements -- Part 11: Wireless LAN Medium Access Control (MAC) and Physical Layer (PHY) Specifications*, IEEE Std. 802.11-2007.

**[0005]** Multiple-input and multiple-output (MIMO), is generally the use of multiple antennas at both a transmitter and a receiver to improve communication performance. It is often considered one of several forms of smart antenna technology. MIMO technology frequently offers significant increases, compared to single input/output technology, in data throughput and link range without additional bandwidth or transmit power. MIMO systems generally achieve this by higher spectral efficiency (e.g., more bits per second per hertz of bandwidth) and link reliability or diversity (e.g., reduced fading). In general, Close Loop (CL) multi-user (MU) MIMO systems require feedback of communications channel information from all the active users. The feedback overhead however, often decreases the efficiency of the MU-MIMO system capacity.

**[0006]** A frequent cellular network implementation may have multiple antennas at a base station (BS) and a single antenna on the mobile station (MS). In such an embodiment, the cost

of the mobile radio may be minimized. As the costs for radio frequency (RF) components in mobile station are reduced, second antennas in mobile device may become more common. Multiple mobile device antennas may currently be used in Wi-Fi  
5 technology (e.g., IEEE 802.11n).

#### SUMMARY

**[0007]** According to one general aspect, a method may include allocating, within a single physical resource unit  
10 (PRU), a plurality of channel sounding groups. Wherein each channel sounding group includes both a frequency division multiplexing (FDM) allocation and a code division multiplexing (CDM) allocation. The method may also include broadcasting, in a downlink direction to one or more mobile stations  
15 in a wireless network, a signal that causes the receiving mobile stations to transmit a channel sounding signal. The method may further include receiving at least one channel sounding signal from at least one of the one or more mobile stations, the channel sounding signal being received in an  
20 uplink direction via one or more channel sounding groups. And, the method may include estimating the channel quality, of the channel used by the physical resource unit, based upon the received at least one channel sounding signal.

**[0008]** According to another example embodiment, an apparatus may include a transceiver, and a controller. In various  
25 embodiments, the apparatus may be configured to allocate, within a single physical resource unit (PRU), a plurality of channel sounding groups. Wherein each channel sounding group includes both a frequency-time domain allocation and a code  
30 domain allocation. In some embodiments, the apparatus may also be configured to broadcast, in a downlink direction to one or more mobile stations in a wireless network, a signal that causes the receiving mobile stations to transmit a channel sounding signal. In various embodiments, the apparatus

may also be configured to receive at least one channel sounding signal from at least one of the one or more mobile stations, the channel sounding signal being received in an uplink direction via one or more channel sounding groups. And, in one embodiment, the apparatus may also be configured to estimate the channel quality, of the channel used by the entire physical resource unit, based upon the received at least one channel sounding signal.

**[0009]** According to another example embodiment, a method may include receiving, in a downlink direction, an allocation, within a single physical resource unit (PRU), of a plurality of channel sounding groups. Wherein each channel sounding group includes both a frequency division multiplexing (FDM) allocation and a code division multiplexing (CDM) allocation. The method may also include broadcasting a channel sounding signal in an uplink direction via one or more channel sounding groups.

**[0010]** According to another example embodiment, an apparatus may include a transceiver, and a controller. In various embodiments, the apparatus may be configured to receive, in a downlink direction, an allocation, within a single physical resource unit (PRU), of a plurality of channel sounding groups. Wherein each channel sounding group includes both a frequency division multiplexing (FDM) allocation and a code division multiplexing (CDM) allocation. The apparatus may also be configured to, in various embodiments, broadcast a channel sounding signal in an uplink direction via the allocated channel sounding groups.

**[0011]** The details of one or more implementations are set forth in the accompanying drawings and the description below. Other features will be apparent from the description and drawings, and from the claims.

**[0012]** A system and/or method for communicating informa-

tion, substantially as shown in and/or described in connection with at least one of the figures, as set forth more completely in the claims.

5

**BRIEF DESCRIPTION OF THE DRAWINGS**

**[0013]** FIG. 1 is a block diagram of an example embodiment of a system in accordance with the disclosed subject matter.

**[0014]** FIG. 2 is a block diagram of an example embodiment of an apparatus in accordance with the disclosed subject matter.  
10

**[0015]** FIG. 3 is a block diagram of an example embodiment of a series of physical resource units in accordance with the disclosed subject matter.

**[0016]** FIG. 4 is a block diagram of an example embodiment of a physical resource unit in accordance with the disclosed subject matter.  
15

**[0017]** FIG. 5 is a block diagram of another example embodiment of a physical resource unit in accordance with the disclosed subject matter.

**[0018]** FIG. 6 is a block diagram of an example embodiment of a system in accordance with the disclosed subject matter.  
20

**[0019]** FIG. 7 is a flow chart of an example embodiment of a technique in accordance with the disclosed subject matter.

**[0020]** FIG. 8 is a flow chart of an example embodiment of a technique in accordance with the disclosed subject matter.  
25

**DETAILED DESCRIPTION**

**[0021]** Referring to the Figures in which like numerals indicate like elements, FIG. 1 is a block diagram of a wireless network 102 including a base station (BS) 104 and mobile stations (MSs) 106, 108, 110, according to an example embodiment. Each of the MSs 106, 108, 110 may be associated with BS 104, and may transmit data in an uplink direction to BS 104, and may receive data in a downlink direction from BS 104, for example. Although only one BS 104 and three mobile stations (MSs 106, 108 and 110) are shown, any number of base stations and mobile stations may be provided in network 102. Also, although not shown, mobile stations 106, 108 and 110 may be coupled to base station 104 via relay stations or relay nodes, for example. The base station 104 may be connected via wired or wireless links to another network (not shown), such as a Local Area Network, a Wide Area Network (WAN), the Internet, etc.. In various embodiments, the base station 104 may be coupled or connected with the other network 120 via an access network controller (ASN) or gateway (GW) 112 that may control, monitor, or limit access to the other network.

**[0022]** FIG. 2 is a block diagram of two example embodiments of apparatuses 201 and 203 in accordance with the disclosed subject matter. In one embodiment, the communications device 201 may include a base station (BS) or a mobile station (MS) such as that illustrated in Fig. 1. In one embodiment, the communications device 201 may include a transceiver 202, a controller 204, and a memory 206. In some embodiments, the transceiver 202 may include a wireless transceiver configured to operate based upon a wireless networking standard (e.g., WiMAX, WiFi, WLAN, etc.). In other embodiments, the transceiver 202 may include a wired transceiver config-

ured to operate based upon a wired networking standard (e.g., Ethernet, etc.). In various embodiments, the controller 204 may include a processor. In various embodiments, the memory 206 may include permanent (e.g., compact disc, etc.), semi-permanent (e.g., a hard drive, etc.), and/or temporary (e.g., volatile random access memory, etc.) memory. For example, some operations illustrated and/or described herein, may be performed by a controller 204, under control of software, firmware, or a combination thereof. In another example, some components illustrated and/or described herein, may be stored in memory 206.

**[0023]** FIG. 2 is also a block diagram of a communications device 203 in accordance with an example embodiment of the disclosed subject matter. In one embodiment, the communications device 203 may include a base station (BS) or a mobile station (MS) such as that illustrated in Fig. 1. In one embodiment, the communications device 203 may include a wireless transceiver 202, a controller 204, and a memory 206. In some embodiments, the transceiver 202 may include a wireless transceiver configured to operate based upon a wireless networking standard (e.g., WiMAX, WiFi, WLAN, etc.). In other embodiments, the transceiver 202 may include a wired transceiver configured to operate based upon a wired networking standard (e.g., Ethernet, etc.). In various embodiments, the controller 204 may include a processor. In various embodiments, the transceiver 202 may include a plurality of antennas, such as antenna #1 211 and antenna #2 212. In some embodiments, the communications device 203 may include at least one identifier 210 configured to substantially uniquely identify each antenna (e.g., antennas 211 and 212) or apparatus 203 as a whole. In various embodiments, the identifier 210 may be stored by the memory 206.

**[0024]** FIG. 3 is a block diagram of an example embodiment of a series of physical resource units (grouped as, for exam-

ple, frames, etc.) in accordance with the disclosed subject matter. In one embodiment, the base station and various mobile stations may communicate with each other using a series or plurality of physical resource units (PRUs) organized into frames or super-frame 300; although, it is understood that various embodiments using other communication standards may organize PRUs differently.

**[0025]** These PRUs may be transmitted over or via a communications channel. The following provides an overall context of the communications channel. In this context, a communications channel may include a medium used to convey information from a sender to a receiver. Fig. 3 illustrates the division of the communications channel as a function of time (e.g., time division multiplexing). In addition, a communications channel may also be divided as a function of frequency, illustrated more completely in Figs. 4 and 5. In various embodiments, this communications channel may include a plurality of frequencies or a bandwidth of frequencies. This bandwidth may be sub-divided into sub-channels. Each of these sub-channels may include their own respective bandwidth. In various embodiments, these sub-channels may generally be of equal size.

**[0026]** In various embodiments, the communications channel may be divided by both time and frequency into physical resource units. In such an embodiment, a physical resource unit may include a given sub-channel or sub-channels for a period of time. These physical resource units, or a subdivision thereof, may provide the fundamental blocks of communication. According to an example embodiment, a physical resource unit may include a group of sub-channels, such as 18 sub-channels (as an example), or any number of sub-channels.

**[0027]** A controlling device (e.g., a base station), in one embodiment, may allocate PRUs amongst client devices (e.g.,

mobile devices). In such an embodiment, the base station may attempt to perform this allocation in such a way as to reduce the number of un-received or un-usable (e.g., garbled, noise ridden, etc.) transmissions. In various embodiments, it may  
5 not be possible to make use of every possible PRU.

**[0028]** Fig. 3 illustrates a plurality of frames. In various embodiments, the plurality of frames may be organized into a super-frame 300. In one embodiment, this super-frame 300 may include frames 302a, 302b, 302, and 302n. Frame 302  
10 may include a down-link (DL) portion and an uplink (UL) portion. In various embodiments, a DL sub-frame 306 may be reserved for communication from the base station to a mobile station. Conversely, an UL sub-frame 310 may be reserved for communication from the mobile station to the base station.  
15 Downlink (DL) may refer to a direction of transmission from base station to a mobile station, and uplink (UL) may refer to a direction of transmission from a mobile station to a base station.

**[0029]** In one embodiment, a frame 302 may include a plurality of DL sub-frames (e.g., DL sub-frames 306a, 306b,  
20 306c, 306, and 306n) and a plurality of UL sub-frames (e.g., UL sub-frames 310a, 310, and 310n). In various embodiments, a mid-amble 308 and pre-amble 304 may, respectively, delineate the transition between the DL and UL portions of the  
25 frame 302 and between frames themselves. In one embodiment, the pre-amble 304 and mid-amble 308 may include a signal that is broadcast to any listening devices (e.g., mobile stations) within the range of the base station or other transmitting device.

**[0030]** Conversely, a DL sub-frame 306 or UL sub-frame 310  
30 may include messages or signals generally intended for a specific receiver or group of receivers. Occasionally these sub-frames may be used to broadcast information (e.g., re-

source allocation, channel condition feedback, etc.). These time based sub-frames may be, in one embodiment, additionally divided by frequency into the PRUs (not shown) which are allocated to mobile stations to either receive or send information. In such an embodiment, the sub-frame may be the practical time division of the communications channel.

**[0031]** In various embodiments, the DL sub-frame 306 may include a plurality of symbols 312. In one specific embodiment, the DL sub-frame 306 may include five symbols 312 and duration of approximately 0.514 ms. In various embodiments, the UL sub-frame 310 may include a plurality of symbols 312. In one specific embodiment, the UL sub-frame 310 may include six symbols 312 and duration of approximately 0.617 ms. In various embodiments, these symbols 312 may include orthogonal frequency-division multiple access (OFDMA) symbols. In one embodiment, an UL PRU may include a bandwidth of 18 sub-channels, and a time duration or length of six symbols 312. In various embodiments, a PUR size may be configurable or predefined. It is understood that the above are merely a few illustrative examples to which the disclosed subject matter is not limited.

**[0032]** FIG. 4 is a block diagram of an example embodiment of a physical resource unit (PRU) 400 in accordance with the disclosed subject matter. In various embodiments, the physical resource unit 400 may be divided both in terms of frequency and time (or symbols). In the illustrated embodiment of PRU 400, the X-axis illustrates division by symbols and the Y-axis illustrates division by frequency or sub-carriers. In various embodiments, the PRU 400 may include a plurality of blocks 401. Please note, that Figs. 4 and 5 are oriented in such a way that the higher frequencies of the RPU 400 are located at the bottom of the figures; it is understood that this orientation is immaterial and non-limiting to the disclosed subject matter and only a graphic design choice.

**[0033]** In various embodiments, the PRU 400 illustrated may include an Up-Link (UL) PRU. The PRU 400 may include 18 sub-carriers or frequency bandwidth sub-divisions, and 6 symbols or time divisions. In such an embodiment, the PRU 400 may  
5 therefore include 108 sub-carriers or blocks. Although, it is understood that the above is merely one illustrative example to which the disclosed subject matter is not limited.

**[0034]** In various embodiments, a portion of the PRU 400 may be allocated to form a plurality of channel sounding  
10 groups (CSGs). In the illustrated embodiment, three CSGs may be allocated, CSG 402, CSG 402b, and CSG 402c. In various embodiments, these CSGs 402 may be allocated or created by a controlling device (e.g., a bases station).

**[0035]** In some embodiments, each of these CSGs 402 may include a plurality of contiguous blocks of the PRU. For example,  
15 it may be seen in the illustrated embodiment that each CSG 402 includes six blocks 401, three sub-carriers high and two symbols wide (3x2). Although, it is understood that the above is merely one illustrative example to which the disclosed  
20 subject matter is not limited.

**[0036]** In this context, because these CSGs 402 include more than one block in length and width, they may be considered to be two-dimensional, having both frequency and time or  
symbol components. This is contrasted with a block group,  
25 such as data 406, which includes only the width of one block or sub-carrier 401, and therefore may be considered one-dimensional, in this context, and only having a frequency component.

**[0037]** Generally, frequency-division multiplexing (FDM) is  
30 a form of signal multiplexing where multiple signals are modulated on different frequency carrier waves or sub-carriers. In various embodiments, a CSG 402 may include a plurality of frequency sub-carriers, and, therefore, be said

to include FDM. Likewise, code-division multiplexing (CDM) is generally a form of signal multiplexing where multiple codes or symbols are used to modulate a signal. In various embodiments, the CSG 402 may include a plurality of symbol  
5 blocks or sub-carriers, and therefore be said to include CDM. In such an embodiment, the two-dimensional CSG 402 may include both FDM and CDM.

**[0038]** In various embodiments, the controlling device (e.g., a base station) may communicate the CSG 402 allocation to one or more listening devices (e.g., a mobile stations) associated with the controlling device. However, it is understood, that in some embodiments, while a BS may transmit such a signal or message some of the MSs may not, for various reasons (e.g., noise, movement out of range,  
15 etc.) receive the signal. This message or signal may, in one embodiment, instruct or cause the MSs to use the allocated CSGs 402 to transmit a channel sounding signal.

**[0039]** In various embodiments, a second message or signal, separate from the allocation message (e.g., a channel quality signal), may be used to trigger or request the transmittal of  
20 the channel sounding signal from the MSs. In some embodiments, this channel sounding signal may indicate that each MS may test the channel quality, a respectively experienced, and selectively transmit a channel sounding signal only if the  
25 measured channel quality exceeds a certain threshold or criteria. In various embodiments, this signal may include the pilot signal 404. Although, it is understood that the above are merely a few illustrative examples to which the disclosed subject matter is not limited.

**[0040]** In such an embodiment, the plurality of MSs may respond using the CSGs 402. In various embodiments, the MSs may respond using each of the CSGs 402, 402b, and 402c. In some embodiments, the channel sounding signal may include a  
30

sounding message including one value for each block of particular CSG (e.g., CSG 402, 402b, and 402c). In various embodiments, this value may be a substantially unique identification code associated with the transmitting MS. In various  
5 embodiments, the same channel sounding signal may be transmitted by a MS using all three CSGs 402, 402b, and 402c.

**[0041]** In various embodiments, the BS may use the received channel sounding signals to estimate or determine the quality of the channel used by the PRU 400. In various embodiments,  
10 this may include determining a channel quality estimation for each MS.

**[0042]** For example, a first MS (MS #1, e.g., MS 106 of Fig. 1) may transmit its channel sounding signal on all three illustrated CSGs 402, 402b, and 402c. Likewise, a second MS  
15 (MS #2, e.g., MS 110 of Fig. 1) may also transmit its channel sounding signal on all three illustrated CSGs 402, 402b, and 402c. However, the BS may receive these signals with various degrees of strength and clarity. In one embodiment, the BS may receive MS #1's channel sounding signal on all three CSGs  
20 402, 402b, and 402c but only receive MS #2's channel sounding signal on CSG 402 and CSG 402c. From this the BS may infer that messages transmitted to MS #2 using the sub-channels comprising CSG 402b may not be received by MS #2. Although, it is understood that the above is merely one illustrative  
25 example to which the disclosed subject matter is not limited.

**[0043]** Returning to the above specific example, the BS may be expecting channel sounding signals from three MSs (e.g., MSs 106, 108 and 110 of Fig. 1). If at least one channel sounding signal is received via a CSG (e.g., CSG 402 which  
30 was used by both MS #1 and MS #2 of the example above), it may be desirable to determine which MS transmitted the received channel sounding signal.

**[0044]** In various embodiments, the controlling device

(e.g., a base station) may assign specific identification codes to each listening device (e.g., a mobile station). In one embodiment, the BS may assign, to each MS or antenna thereof associated with it, a substantially unique identification code. In some embodiments, these substantially unique identification codes may be substantially orthogonal (e.g., a Walsh code, etc.). In such an embodiment, the BS may be able to determine, using the orthogonal codes, which MSs or antennas transmitted the channel sounding signal for each CSG 402. For example, the BS may use the XOR Boolean operation to correlate a received signal with the identification code associated with a given MS or antenna.

**[0045]** In various embodiments, a channel sounding group 402 may include one block (e.g., a code symbol or frequency band) for each mobile station or antenna associated with the allocating or controlling device (e.g., a base station). In such an embodiment, the CSG 402 may include enough symbols to uniquely identify each MS or antenna. For example, a system with six MSs or antennas (e.g., 3 MSs each with 2 antennas) may be uniquely identified via orthogonal identification codes of six bits. In such an embodiment, a 3x2 CSG (e.g., CSG 402, 402b or 402c) would include enough symbols (2 symbols per 3 frequency bands, totaling 6 sub-carriers 401) to fully communicate the assigned identification code. Although, it is understood that the above are merely a few illustrative examples to which the disclosed subject matter is not limited.

**[0046]** In various embodiments, if the number of MSs or antennas associated with a BS changes (e.g., moving in or out of range, etc.), the BS may reassign identification codes and subsequently allocate differently sized CSGs 402. For example, if only 4 MSs exist a CSG may include a 2x2 block (not illustrated). Or, if 8 MSs exist a CSG may include a 4x2 block. Although, it is understood that the above is merely

one illustrative example to which the disclosed subject matter is not limited.

**[0047]** In less desirable embodiments, a channel sounding group (CSG) may not be large enough to allow for uniquely  
5 identifying all associated MSs or antennas. For example, if seven MSs or antennas exist, the CSG 402 (a 3x2 CSG) would include one less block or sub-carrier 401 (symbol or frequency band) than needed to use Walsh coding to provide orthogonal identification codes. In such an embodiment, the BS  
10 may re-assign mostly unique identifiers to each MS or, in one embodiment, the BS may simply accept that the origin of some channel sounding signals may be indeterminate and assign identifiers in such a way as to minimize or manage that possibility. It is understood that in other embodiments, the  
15 size of the CSG may be increased to accommodate the extra MSs or antennas.

**[0048]** In various embodiments, the size of the CSGs may be determined by the lowest power of two (e.g., 2, 4, 8, 16, etc.) that may accommodate the MSs or antennas. In another  
20 embodiment, the CSGs may be rectangular. In yet another embodiment, the CSGs may be non-rectangular or jagged, as would occur with a two-dimensional CSG of five blocks 401. Although, it is understood that the above are merely a few illustrative examples to which the disclosed subject matter is  
25 not limited.

**[0049]** In various embodiments, the MSs may be divided into user groups. In such an embodiment, the BS may allocate CSGs, not to all the MSs associated with BS but to a selected user group. In various embodiments, this may improve the  
30 channel estimation accuracy of the physical resource unit. Conversely, in one embodiment, the CSGs within one PRU can be allocated to the multiple user groups, which may increase the sounding users.

**[0050]** In various embodiments, the controlling device (e.g., a base station) may allocate the number and position (within the PRU) of the CSGs (e.g., CSG 402, 402b, and 402c) to assist channel quality estimation. For example, in various  
5 embodiments, frequency selective fading is the phenomenon that channel quality often differs by frequency. Two identical signals, transmitted on different frequencies, may not both be received. In one frequency band the noise or interference may be substantial, while in a second frequency band  
10 it may be non-existent, to highlight the phenomenon. Although, it is understood that the above is merely one illustrative example of an affecter of channel quality to which the disclosed subject matter is not limited.

**[0051]** In one embodiment, the BS may allocate a first CSG block (e.g., CSG #1 402) at the lower frequency edge of the PRU. In such an embodiment, the BS may then allocate a second CSG block (e.g., CSG #2 402b) at the upper frequency edge of the PRU. In various embodiments, the PRU may experience above average or even significant frequency selective fading  
20 at the edges of the PRU's frequency range. This is often referred to as "frequency roll-off". In such an embodiment, by allocating CSGs to the frequency edges of the PRU 400, a "worst case" estimation of channel quality may be obtained.

**[0052]** In another embodiment, the BS may allocate CSGs 402 and 402b to the edges of the frequency range of the PRU 400, and a third or additional CSG 402c to middle or substantially the middle of the frequency range of the PRU 400. An embodiment with three CSGs (e.g., CSGs 402, 402b and 402c) may produce three separate channel quality data points generally  
30 spread across the entire frequency range of the PRU 400. In such an embodiment, the BS may obtain a more accurate estimation of the channel's quality. In various embodiments, additional CSG's may be used. In some embodiments, the BS may

allocate CSGs or different sizes; although if substantially orthogonal identification codes are used the benefit of this may not be great.

**[0053]** In various embodiments, as a CSG 402 is made or allocated to be longer in the frequency domain, the value of the information returned by the MS's channel sounding signal may be reduced (relative to shorter frequency-wise CSGs). Each CSG 402 may provide an average channel quality estimation for that CSG. If a 3x2 CSG is used, in one embodiment, three frequency sub-channels may be estimated or averaged together to provide a single data point. In various embodiments, this may be acceptable as the channel quality from a first sub-carrier may be roughly similar to a sub-carrier one frequency block away. But, in various embodiments, the correlation between the channel quality of two sub-channels often decreases as the distance (frequency-wise) from them increase. For example, channel quality of that first sub-carrier may be less similar to a sub-carrier three frequency blocks away, and even less similar to a sub-carrier five blocks away. Therefore, in various embodiments, the BS may allocate CSG blocks within a pre-defined or configurably defined acceptable frequency height.

**[0054]** In various embodiments, the BS may also allocate the CSGs 402 based upon other uses made of the RPU 400. For example, a number of blocks may be unmovable or pre-allocated, such as, pilot blocks 404. In such an embodiment, certain blocks may be pre-allocated or positionally defined by a communications standard or protocol. An example may include the pilot blocks or tones 404 that may, in one embodiment, be used by the BS to transmit the BS's sounding signal which may be used for signal strength measurements, channel response estimation, etc.. Although, it is understood that the above are merely a few illustrative examples to which the disclosed subject matter is not limited.

**[0055]** In another embodiment, the BS may also allocate CSGs 402 based upon more configurable users made of the RPU 400. For example, the BS may also allocate data blocks (e.g., data 406). In such an embodiment, the BS may allocate  
5 both the data blocks (e.g., data 406) and the CSGs (e.g., CSGs 402, 402b, and 402c) such that interference between the blocks is reduced (e.g., increased spacing), that one type (e.g., data) has priority over the other if a conflict arises (e.g., if both desired data usage and CSG usage would exceed  
10 the size of the PRU 400, etc.), etc.. Although, it is understood that the above are merely a few illustrative examples to which the disclosed subject matter is not limited.

**[0056]** In various embodiments, once the MS's channel sounding signals have been received via the CSGs 402, the BS  
15 may estimate the channel quality of the channel used by the RPU 400. In one embodiment, the BS may compare the received channel sounding signal to an expected channel sounding signal to determine the quality of the received sounding signal and, based upon that, the quality of the channel. In various  
20 embodiments, the BS may determine qualities such as, for example, signal-to-noise ratio, a signal-to-interference and noise ratio, received signal strength, or any other channel quality; although, it is understood that the above are merely a few illustrative examples to which the disclosed subject  
25 matter is not limited.

**[0057]** In one embodiment, the BS may simply average the channel quality provided via the CSGs 402. In another embodiment, the BS may use a finer level of granularity to estimate the channel quality. In one embodiment, a rough curve  
30 or values representing a mathematical equivalent may be formed using the data points provided by the CSGs 402. In another embodiment, a pre-defined or configurable weighting of the data points provided by the CSGs 402 may be used. Al-

though, it is understood that the above are merely a few illustrative examples to which the disclosed subject matter is not limited.

**[0058]** In various embodiments, this channel quality estimation may occur for each MS or antenna. In such an embodiment, the channel quality estimated for a first and a second MS may differ radically. In various embodiments, if an MS estimates the channel quality to be above or certain criteria or threshold, the MS may respond with a channel sounding signal. In such an embodiment, the MS may transmit or broadcast this channel sounding signal on all allocated CSGs (e.g., CSG 402, 402b, and 402c). Although, it is understood that due to channel conditions (e.g., frequency selective fading, etc.) the BS may not receive the MS's channel sounding signal on all of the CSGs, as described above.

**[0059]** In some embodiments, the BS may then allocate data blocks (e.g., data 406) to each MS based upon the estimated channel quality associated with the respective MS. Continuing the example above, the BS may, in one embodiment, attempt to allocate data blocks to the third MS that are in, as much as possible, the middle to lower end of the RPU's 400 frequency range. The BS may, in one embodiment, freely allocate any data blocks to the second MS. While, in one embodiment, the BS may allocate none or little data blocks to the first non-responsive MS. Although, it is understood that the above are merely a few illustrative examples to which the disclosed subject matter is not limited. In various embodiments, the BS may not include the fine level or granularity to position data block allocation within the frequency range based upon individual CSG 402 responses.

**[0060]** FIG. 5 is a block diagram of an example embodiment of a physical resource unit 500 in accordance with the disclosed subject matter. Fig. 5 illustrates an example embodi-

ment mentioned above (in reference to Fig. 4). In such an embodiment, the BS or allocating device may allocate only two CSGs 502 and 502b. In various embodiments, these CSGs 502 and 502b may be allocated at the edge of the RPU's 500 frequency range. Also, Fig. 5 illustrates that the CSGs 502 and 502b need not be limited to a 3x2 configuration but may be allocated in different shapes and orientations (e.g., 2x4, etc.). In such an embodiment, the CSGs 502 and 502b may accommodate up to eight substantially orthogonal identification codes and therefore up to eight MSs or antennas. Although, it is understood that the above are merely a few illustrative examples to which the disclosed subject matter is not limited.

**[0061]** FIG. 6 is a block diagram of an example embodiment of a system 600 in accordance with the disclosed subject matter. In one embodiment, the system 600 may include a BS 602, a first mobile station 604, a second mobile station 606. In various embodiments, the mobile stations may include a first antenna and a second antenna. However, it is understood that the disclosed subject matter is not limited to a fixed number of antennas and that Fig. 6 is merely an illustrative embodiment.

**[0062]** In one embodiment, the BS 602 may establish an association or a connection with at least one mobile station, as described above. In various embodiments, this establishment may include broadcasting a message identifying the BS 602, receiving a message from the respective MSs requesting an association, and authenticating the MS; although, it is understood that the above is merely one illustrative example to which the disclosed subject matter is not limited.

**[0063]** In one embodiment, the BS 602 may broadcast or individually transmit an identification code assignment message 610 to each MS 604 and 606. In various embodiments, this

identification code assignment message 610 may include a substantially unique identifier or code to each mobile station (e.g., MSs 604 and 606) or to each antenna of the MSs. In various embodiments, the identification code may be substantially orthogonal with every other MS associated with the BS 602, as described above. In such an embodiment, this code may be used to identify from which MS or antenna a message or signal (e.g., channel sounding signal 614) originates, as described above.

10 **[0064]** In various embodiments, the code assignment message 610 may include a specific message. In another embodiment, the code assignment message 610 may be included as part of another message (e.g., a MS attachment response message, etc.). In such an embodiment, the code assignment message  
15 610 may include a parameter or element of the other or carrier message. In one such embodiment, the code assignment message 610 may be or include a type-length-value (TLV) element that specifies that it is a parameter or element including the code assignment and a value for the code or codes assignment. A specific embodiment of a substantially uniquely  
20 identifiable code assignment is discussed above in reference to Fig. 4. Although, it is understood that the above are merely a few illustrative examples to which the disclosed subject matter is not limited.

25 **[0065]** In one embodiment, the BS 602 may transmit or broadcast a channel sounding group (CSG) allocation message 611. In various embodiments, the CSG allocation message 611 may include the sub-carrier allocations for the channel sounding groups allocated by the BS 602, as described above.  
30 In such an embodiment, the receiving MSs 604 and 606 may then know to transmit their channel sounding signals 614 via the allocated sub-carriers. In various embodiments, the CSG allocation message 611 may be included as part of another resource block allocation message (e.g., including data alloca-

tion, etc.) transmitted or broadcast from the BS 602.

**[0066]** In one embodiment, the BS 602 may transmit or broadcast a signal or message, which may be referred to as a channel quality signal 612, to at least one mobile station actively associated with the base station (e.g., MSs 604 and 606). In various embodiments, the channel quality signal 612 may cause or indicate to the receiving MSs 604 and 606 that they should transmit their channel sounding signals 614 during the allocated sub-carriers indicated by the CSG allocation message 611, as described above.

**[0067]** In various embodiments, the CSG allocation message 611 and the channel quality signal 612 may be the same message or signal. For example, the allocation of channel soundings groups (CSGs) within the CSG allocation message 611 may indicate that the receiving MSs should transmit their channel sounding signal, via the allocated CSGs, during the next available uplink period. In such an embodiment, the channel allocation message 611 may act as the channel quality signal 612. In another embodiment, a CSG allocation message 611 may only be transmitted when the CSGs are first allocated or changed. The CSGs sub-carriers, in such an embodiment, may be remembered by the MSs 604 and 606 and used when a channel quality signal 612 is received. Although, it is understood that the above are merely a few illustrative examples to which the disclosed subject matter is not limited.

**[0068]** In various embodiments, the BS 602 may transmit a channel quality signal 612 opportunistically. In another embodiment, the BS 602 may transmit a channel quality signal 612 periodically or, in one embodiment, as part of every frame. In various embodiments in which the channel quality signal 612 is transmitted opportunistically, the BS 602 may monitor or accumulate data regarding the communications channel conditions (e.g., number of resend requests, number of

MSs, channel quality experienced by the BS 602, etc.). In such an embodiment, the BS 602 may broadcast a channel quality signal 612 when it is determined that the communications channel condition has fallen below an acceptable standard or threshold. In various embodiments, this standard or threshold may be predetermined, configurable, or dynamically adjustable, etc. In various embodiments, this standard or threshold may be a relative (versus absolute) standard (e.g., a rate of change of the communications channel's condition, etc.).

**[0069]** In various embodiments, the opportunistic unsolicited transmission of the channel quality signal 612 may reduce the overall overhead of MIMO feedback (e.g., as compared to non-opportunistic schemes). In some embodiments, the periodic or opportunistic unsolicited transmission of the channel quality signal 612 may reduce the power requirements or drain experienced by the MSs (e.g., due to the reduced channel sounding signals 614).

**[0070]** In some embodiments, each MS 604 and 606 may transmit a channel sounding signal 614 to the BS 602 via the allocated CSGs (as indicated by CSG allocation message 611). As described above, in various embodiments, each MS may transmit its identification code, as received by the code assignment message 610. In an example embodiment, each MS (or antenna) may be assigned a unique code, such as a different orthogonal Code Division Multiple Access (CDMA) code via code assignment message 610. Each MS (or each antenna in a multiple antenna embodiment) may encode its channel sounding signal 614 using the orthogonal CDMA code assigned to the MS, as described above.

**[0071]** In various embodiments, the BS 602 may perform channel quality estimation, as illustrated by Block 616. As described above, in various embodiments, the BS 602 may, for

each CSG, determine which if the MSs 604 and 606 transmitted any received channel sounding signals 614. In various embodiments, it may make this determination using the assigned MS identification codes.

5     **[0072]**     As described above, in various embodiments, the BS 602 may compare the received channel sounding signals 614 to an expected channel sounding signal. Using this comparison, the BS 602 may determine channel quality characteristics, for each MS 404 and 406 associated with the BS 602 as described  
10 above.

**[0073]**     In various embodiments, the BS 602 may use the determined individual MS channel quality estimates to allocate resources to the MS or antennas (e.g., MSs 604 and 606), as described above. In various embodiments, the BS 602 may assume that channel quality in the uplink (UL) direction correlates well with the channel quality in the downlink (DL) direction, and allocate both DL and UL resources. In one embodiment, resource allocation message 616 may include physical resource unit or sub-carrier allocation to specific MSs  
15 (e.g., MSs 604 and 606). In various embodiments, the resource allocation message 616 may be of the same type or form as the CSG allocation message 611.  
20

**[0074]**     FIG. 7 is a flow chart of an example embodiment of a technique 700 in accordance with the disclosed subject matter.  
25

**[0075]**     Block 702 illustrates that, in one embodiment, an association between the base station and at least one mobile station (MS) may be established via a communications channel, wherein the communications channel is divided into physical resource units (PRUs), as described above. In various embodiments, establishing may include actions or steps taken by a base station. In some embodiments, steps or actions taken by a mobile station or other device may be outside the scope  
30

of the actions illustrated by Block 702; although, it is understood such mobile station or other device actions may be the cause or effects of establishment actions taken by a base station or apparatus employing the described technique. In various embodiments, the action(s) described above may be performed by one or more of the following: a base station 104 of Fig. 1, a transceiver 202 of Fig. 2, or a base station 602 of Fig. 6, as described above.

**[0076]** Block 704 illustrates that, in one embodiment, a substantially orthogonal identification code may be assigned to each of the one or more mobile stations, as described above. In some embodiments, assigning may include transmitting the identification code to the mobile stations. In various embodiments, the action(s) described above may be performed by one or more of the following: a base station 104 of Fig. 1, the transceiver 202 or controller 204 of Fig. 2, or a base station 602 of Fig. 6, as described above.

**[0077]** Block 706 illustrates that, in one embodiment, a plurality of channel sounding groups (CSGs) may be allocated, within a single physical resource unit (PRU), as described above. In various embodiments, the CSGs may include both a frequency division multiplexing (FDM) allocation and a code division multiplexing (CDM) allocation, as described above. In another embodiment, allocating may include allocating, for each channel sounding group, a contiguous two-dimensional block of the physical resource unit, as described above. In yet another embodiment, allocating may include allocating to the channel sounding group either one code symbol or one frequency band for each mobile station associated with an allocating device, as described above. In further embodiments, allocating may also include allocating a first channel sounding group at a lower frequency edge of the PRU, and allocating a second channel sounding group at an upper frequency edge of the PRU, as described above. In some embodiments,

allocating may also include allocating a third channel sounding group substantially in the middle of the frequency range of the PRU, as described above. In one embodiment, allocating may include increasing channel quality estimation accuracy by allocating channel sounding groups to compensate for frequency selective fading, as described above. In various embodiments, allocating may include transmitting the allocation to one or more mobile stations, as described above. In various embodiments, the action(s) described above may be performed by one or more of the following: a base station 104 of Fig. 1, the transceiver 202 or controller 204 of Fig. 2, or a base station 602 of Fig. 6, as described above.

**[0078]** Block 708 illustrates that, in one embodiment, a signal may be broadcast, in a downlink direction to one or more mobile stations in a wireless network. Wherein the causes the receiving mobile stations to transmit a channel sounding signal, as described above. In various embodiments, broadcasting may include transmitting a message that indicates the channel sounding groups allocation, as described above. In various embodiments, the action(s) described above may be performed by one or more of the following: a base station 104 of Fig. 1, the transceiver 202 of Fig. 2, or a base station 602 of Fig. 6, as described above.

**[0079]** Block 710 illustrates that, in one embodiment, at least one channel sounding signal from at least one of the one or more mobile stations, may be received, as described above. In various embodiments, the channel sounding signal may be received in an uplink direction via one or more channel sounding groups, as described above. In some embodiments, the received signal may include a sounding signal encoded by a Code Division Multiple Access (CDMA) signal to provide a CDMA encoded sounding signal, as described above. In another embodiment, receiving may include receiving the assigned orthogonal identification code assigned to the

transmitting respective mobile station, as described above. In various embodiments, the action(s) described above may be performed by one or more of the following: a base station 104 of Fig. 1, the transceiver 202 of Fig. 2, or a base station 602 of Fig. 6, as described above.

**[0080]** Block 712 illustrates that, in one embodiment, communications resources may be allocated based upon the received at least one signal from at least one of the one or more mobile stations, as described above. In some embodiments, allocating may include transmitting or broadcasting the allocation to one or more mobile stations. In various embodiments, the action(s) described above may be performed by one or more of the following: a base station 104 of Fig. 1, the transceiver 202 or controller 204 of Fig. 2, or a base station 602 of Fig. 6, as described above.

**[0081]** FIG. 8 is a flow chart of an example embodiment of a technique 800 in accordance with the disclosed subject matter.

**[0082]** Block 802 illustrates that, in one embodiment, an identification code may be received, in a downlink direction, as described above. In various embodiments, the identification code may identify the receiving apparatus in a manner that is substantially orthogonal and substantially unique compared to other assigned identification codes, as described above. In various embodiments, the action(s) described above may be performed by one or more of the following: the mobile stations 106, 108, or 110 of Fig. 1, the transceiver 202, memory 206, or identifier 210 of Fig. 2, or the mobile station 604 or 606 of Fig. 6, as described above.

**[0083]** Block 804 illustrates that, in one embodiment, an allocation, within a single physical resource unit (PRU), of a plurality of channel sounding groups may be received, in a downlink direction, as described above. In various embodi-

ments, each channel sounding group may include both a frequency division multiplexing (FDM) allocation and a code division multiplexing (CDM) allocation, as described above. In some embodiments, channel sounding group may include a contiguous two-dimensional block of the physical resource unit, as described above. In various embodiments, the action(s) described above may be performed by one or more of the following: the mobile stations 106, 108, or 110 of Fig. 1, the transceiver 202 of Fig. 2, or the mobile station 604 or 606 of Fig. 6, as described above.

**[0084]** Block 806 illustrates that, in one embodiment, a channel sounding signal may be broadcast or transmitted in an uplink direction via one or more channel sounding groups, as described above. In various embodiments, the channel sounding signal may include the received identification code, as described above. In various embodiments, the action(s) described above may be performed by one or more of the following: the mobile stations 106, 108, or 110 of Fig. 1, the transceiver 202 of Fig. 2, or the mobile station 604 or 606 of Fig. 6, as described above.

**[0085]** Implementations of the various techniques described herein may be implemented in digital electronic circuitry, or in computer hardware, firmware, software, or in combinations of them. Implementations may be implemented as a computer program product, *i.e.*, a computer program tangibly embodied in an information carrier, *e.g.*, in a machine-readable storage device or in a propagated signal, for execution by, or to control the operation of, data processing apparatus, *e.g.*, a programmable processor, a computer, or multiple computers. A computer program, such as the computer program(s) described above, can be written in any form of programming language, including compiled or interpreted languages, and can be deployed in any form, including as a stand-alone program or as a module, component, subroutine, or other unit suitable for

use in a computing environment. A computer program can be deployed to be executed on one computer or on multiple computers at one site or distributed across multiple sites and interconnected by a communication network.

5     **[0086]**     Method steps may be performed by one or more programmable processors executing a computer program to perform functions by operating on input data and generating output. Method steps also may be performed by, and an apparatus may be implemented as, special purpose logic circuitry, e.g., an  
10    FPGA (field programmable gate array) or an ASIC (application-specific integrated circuit).

**[0087]**     Processors suitable for the execution of a computer program include, by way of example, both general and special purpose microprocessors, and any one or more processors of  
15    any kind of digital computer. Generally, a processor will receive instructions and data from a read-only memory or a random access memory or both. Elements of a computer may include at least one processor for executing instructions and one or more memory devices for storing instructions and data.  
20    Generally, a computer also may include, or be operatively coupled to receive data from or transfer data to, or both, one or more mass storage devices for storing data, e.g., magnetic, magneto-optical disks, or optical disks. Information carriers suitable for embodying computer program instructions  
25    and data include all forms of non-volatile memory, including by way of example semiconductor memory devices, e.g., EPROM, EEPROM, and flash memory devices; magnetic disks, e.g., internal hard disks or removable disks; magneto-optical disks; and CD-ROM and DVD-ROM disks. The processor and the memory  
30    may be supplemented by, or incorporated in special purpose logic circuitry.

**[0088]**     While certain features of the described implementations have been illustrated as described herein, many modifi-

cations, substitutions, changes and equivalents will now occur to those skilled in the art. It is, therefore, to be understood that the appended claims are intended to cover all such modifications and changes as fall within the scope of  
5 the embodiments.

**CLAIMS:**

1. A method comprising:  
allocating, within a single physical resource unit (PRU), a plurality of channel sounding groups,  
5 wherein each channel sounding group includes both a frequency-time domain code division multiplexing (CDM) allocation;  
broadcasting, in a downlink direction to one or more mobile stations in a wireless network, a signal that causes the receiving mobile stations to transmit a channel sounding signal;  
10 receiving at least one channel sounding signal from at least one of the one or more mobile stations, the channel sounding signal being received in an uplink direction via one or more channel sounding groups; and  
15 estimating the channel quality, of the channel used by the physical resource unit, based upon the received at least one channel sounding signal.
- 20 2. The method of claim 1 wherein the received signal comprises a sounding signal encoded by a Code Division Multiple Access (CDMA) signal to provide a CDMA encoded sounding signal.
- 25 3. The method of claim 1 wherein allocating includes allocating, for each channel sounding group, a contiguous two-dimensional block of the physical resource unit.
4. The method of claim 1 wherein allocating includes allocating to the channel sounding group sub-carrier for each mobile station associated with an allocating device.  
30
5. The method of claim 1 wherein allocating includes:  
allocating a first channel sounding group at a lower frequency edge of the PRU; and  
35

allocating a second channel sounding group at a higher frequency edge of the PRU.

6. The method of claim 5 wherein allocating includes:

5 allocating a third channel sounding group substantially in a middle of the frequency range of the PRU.

7. The method of claim 1 further including:

10 allocating communications resources based upon the received at least one signal from at least one of the one or more mobile stations.

8. The method of claim 1 wherein broadcasting includes:

15 transmitting a message that indicates the channel sounding groups allocation.

9. The method of claim 1 wherein allocating includes:

20 allocating the channel sounding groups to a selected portion of the one or more mobile stations forming a user group; and wherein broadcasting includes:

a signal that causes only the mobile station(s) of the selected user group to transmit a channel sounding signal.

10. The method of claim 1 further including:

25 assigning to each of the one or more mobile stations a substantially orthogonal identification code; and wherein receiving at least one signal from at least one of the one or more mobile stations includes receiving the assigned orthogonal identification code assigned to the respective transmitting mobile station.

11. The method of claim 1 wherein allocating includes:

35 increasing channel quality estimation accuracy by allocating channel sounding groups such as a contiguous two-dimensional block of the physical resource unit to compensate for frequency selective fading.

12. An apparatus comprising:

a transceiver; and

a controller;

wherein the apparatus is configured to:

5 allocate, within a single physical resource unit (PRU), a plurality of channel sounding groups,

wherein each channel sounding group includes a frequency-time domain allocation and a code domain allocation; broadcast, in a downlink direction to one or more mobile stations in a wireless network, a signal that causes the receiving mobile stations to transmit a channel sounding signal; receive at least one channel sounding signal from at least one of the one or more mobile stations, the channel sounding signal being received in an uplink direction via one or more channel sounding groups; and

15 estimate the channel quality, of the channel used by the entire physical resource unit, based upon the received at least one channel sounding signal.

20 13. The apparatus of claim 12 wherein the apparatus is configured to allocate, for each channel sounding group, a contiguous two-dimensional block of the physical resource unit.

14. The apparatus of claim 12 wherein the apparatus is configured to allocate to the channel sounding group either one code symbol or one frequency band for each mobile station associated with an allocating device.

15. The apparatus of claim 12 wherein the apparatus is configured to allocate:

a first channel sounding group at a lower frequency edge of the PRU;

a second channel sounding group at a higher frequency edge of the PRU; and

35 a third channel sounding group substantially in a middle of a frequency range of the PRU.

16. The apparatus of claim 12 wherein the apparatus is configured to allocate communications resources based upon the received at least one signal from at least one of the one or  
5 more mobile stations.

17. The apparatus of claim 12, wherein the apparatus is configured to:

assign to each of the one or more mobile stations a substantially orthogonal identification code; and  
10 receive, as part of the channel sounding signal, the assigned orthogonal identification code assigned to the respective transmitting mobile station.

15 18. A method comprising:

receiving, in a downlink direction, an allocation, within a single physical resource unit (PRU), of a plurality of channel sounding groups,

wherein each channel sounding group includes a frequency-time domain allocation and code domain allocation; and  
20 broadcasting a channel sounding signal in an uplink direction via one or more channel sounding groups.

19. The method of claim 18 further comprising:

receiving, in a downlink direction, an identification code that identifies the receiving apparatus in a manner that is substantially orthogonal and substantially unique compared to other assigned identification codes; and  
wherein the channel sounding signal includes the received  
30 identification code.

20. The method of claim 18 wherein each channel sounding group includes a contiguous two-dimensional block of the physical resource unit.

35

21. An apparatus comprising:

a transceiver; and

a controller;

wherein the apparatus is configured to:

5 receive, in a downlink direction, an allocation, within a single physical resource unit (PRU), of a plurality of channel sounding groups,

wherein each channel sounding group includes a frequency-time domain code division multiplexing (CDM) allocation; and

10 broadcast a channel sounding signal in an uplink direction via the allocated channel sounding groups.

22. A method comprising:

15 allocating, within a single physical resource unit (PRU), a plurality of channel sounding groups,

wherein each channel sounding group includes both a frequency domain and time domain allocation;

20 broadcasting, in a downlink direction to one or more mobile stations in a wireless network, a signal that causes the receiving mobile stations to transmit a channel sounding signal;

25 receiving at least one channel sounding signal from at least one of the one or more mobile stations, the channel sounding signal being received in an uplink direction via one or more channel sounding groups; and

estimating the channel quality, of the channel used by the physical resource unit, based upon the received at least one channel sounding signal.

30 23. An apparatus comprising:

a transceiver; and

a controller;

wherein the apparatus is configured to:

35 allocate, within a single physical resource unit (PRU), a plurality of channel sounding groups,

wherein each channel sounding group includes a code division multiplexing (CDM) allocation in both the frequency domain and the time domain;

broadcast, in a downlink direction to one or more mobile stations in a wireless network, a signal that causes the receiving mobile stations to transmit a channel sounding signal; receive at least one channel sounding signal from at least one of the one or more mobile stations, the channel sounding signal being received in an uplink direction via one or more channel sounding groups; and estimate the channel quality, of the channel used by the entire physical resource unit, based upon the received at least one channel sounding signal.

24. A method comprising:

receiving, in a downlink direction, an allocation, within a single physical resource unit (PRU), of a plurality of channel sounding groups,

wherein each channel sounding group includes a frequency domain allocation and time domain allocation; and broadcasting a channel sounding signal in an uplink direction via one or more channel sounding groups.

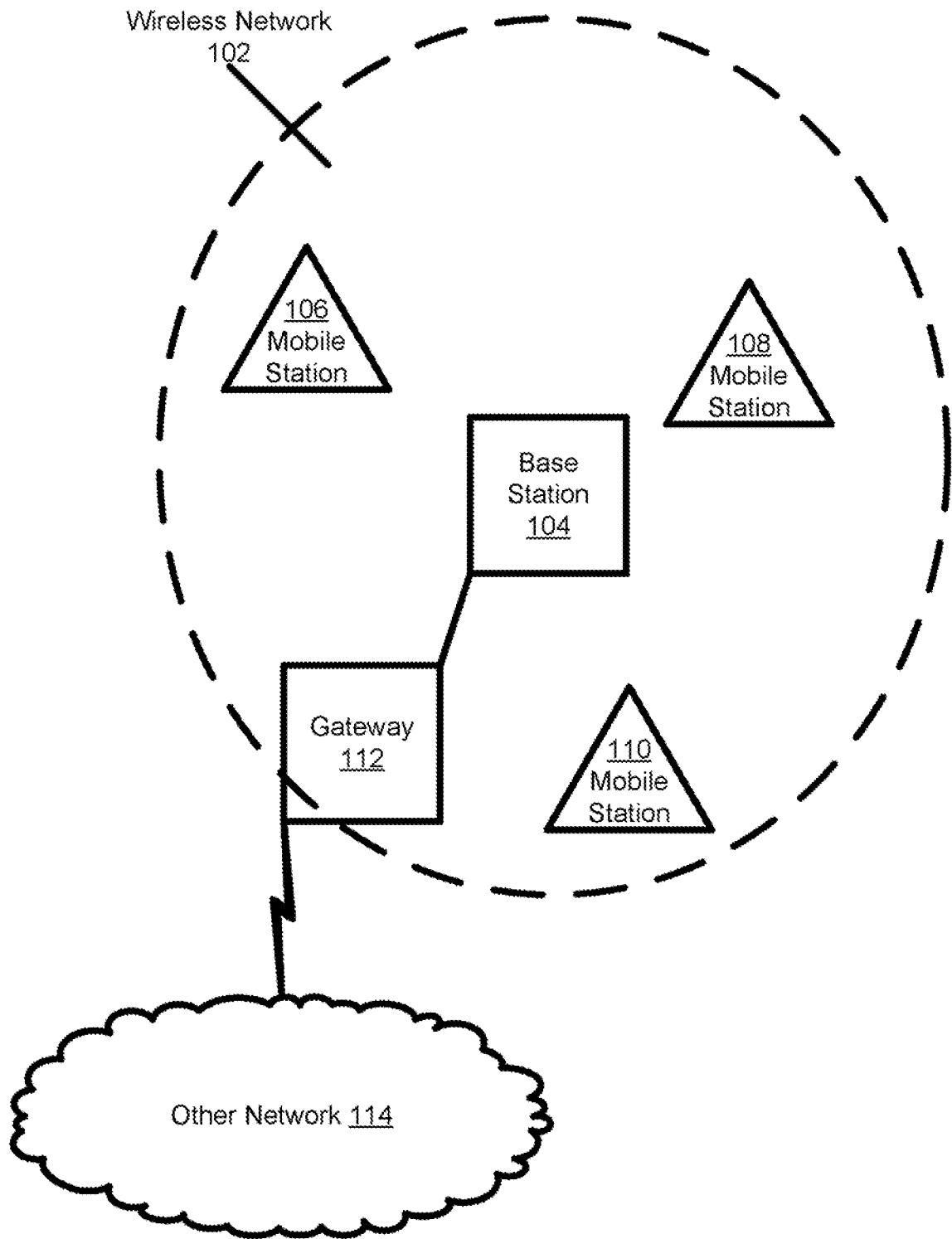
25. An apparatus comprising:

a transceiver; and  
a controller;

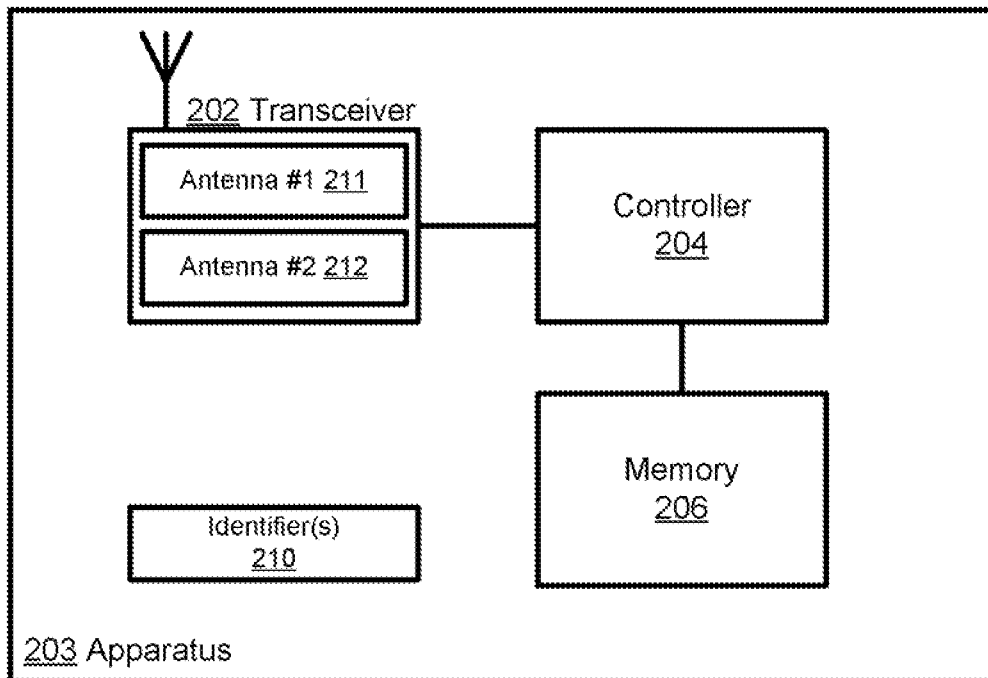
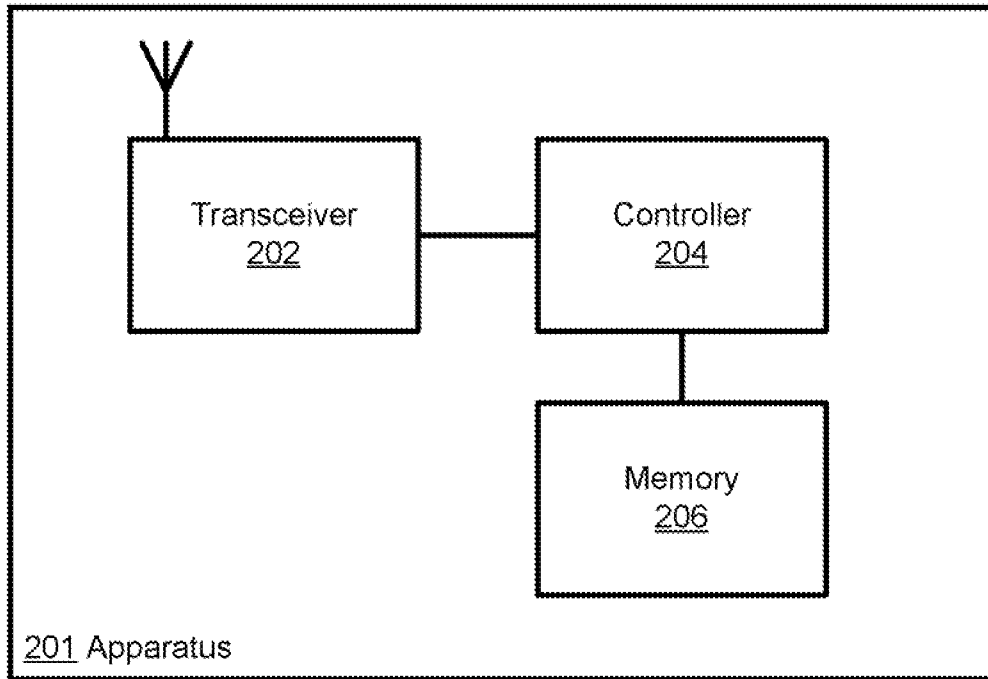
wherein the apparatus is configured to:

receive, in a downlink direction, an allocation, within a single physical resource unit (PRU), of a plurality of channel sounding groups,

wherein each channel sounding group includes a code division multiplexing (CDM) allocation in both the frequency domain and the time domain; and broadcast a channel sounding signal in an uplink direction via the allocated channel sounding groups.



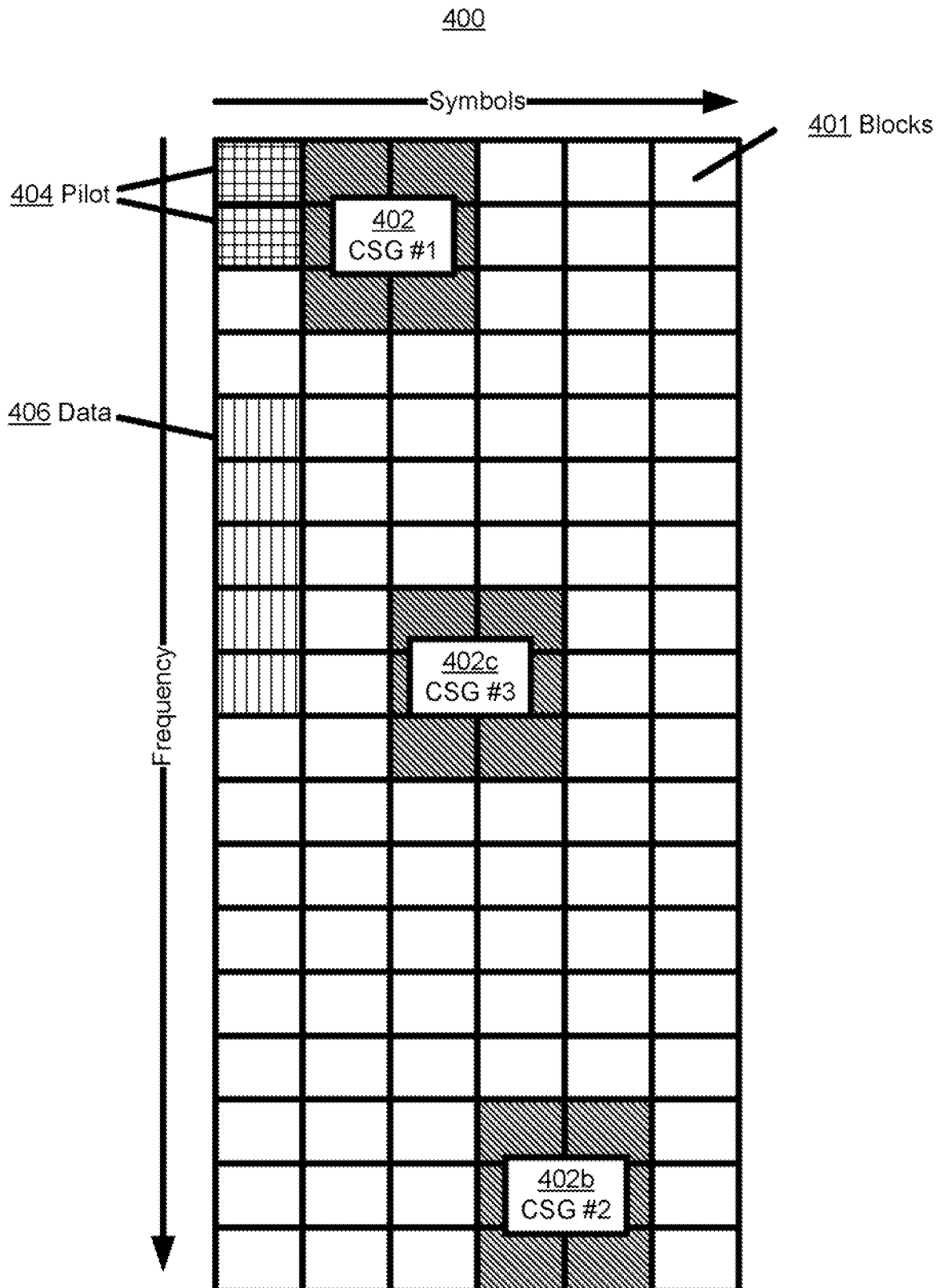
**FIG. 1** 100



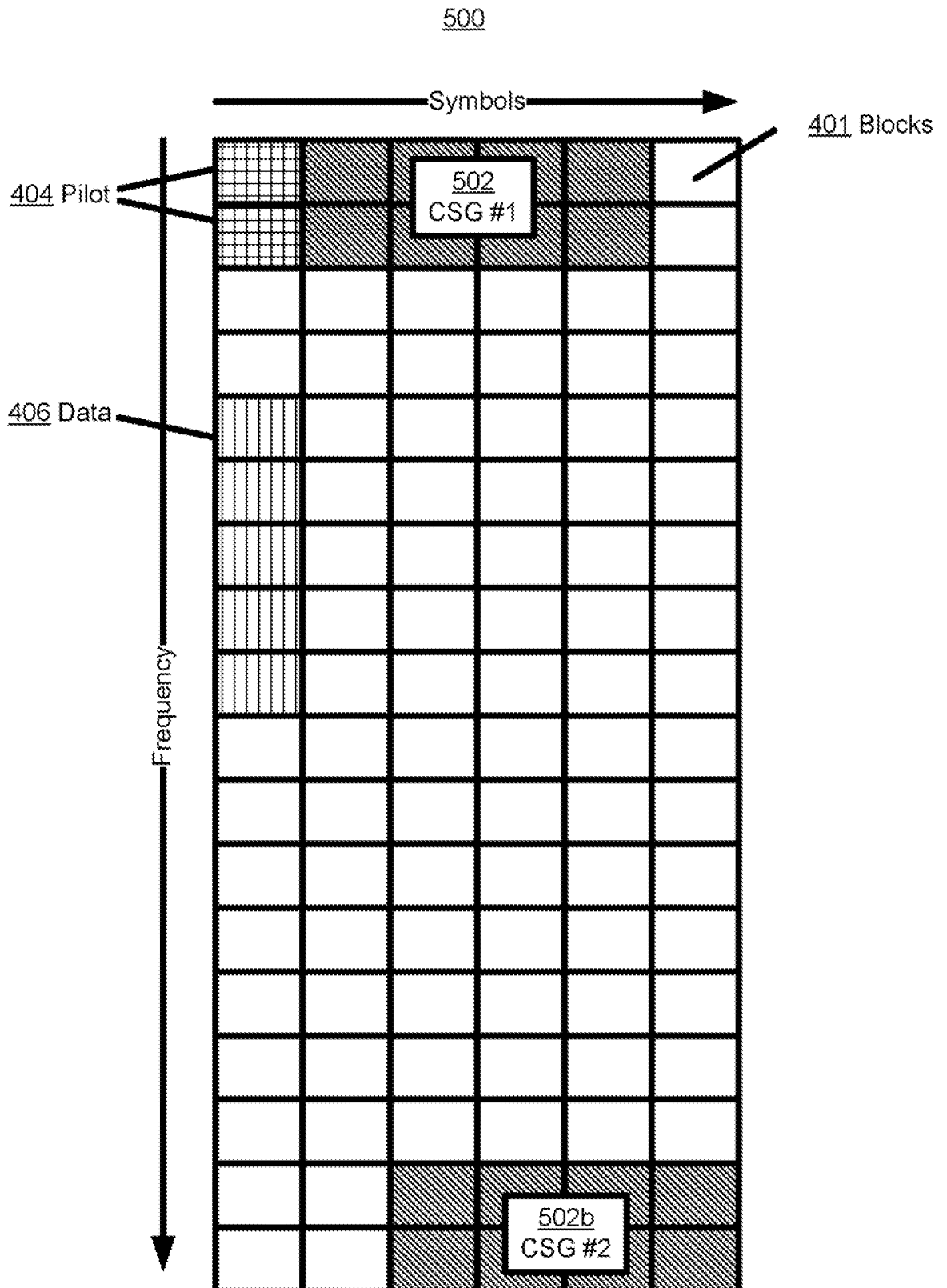
**FIG. 2**



# FIG. 4

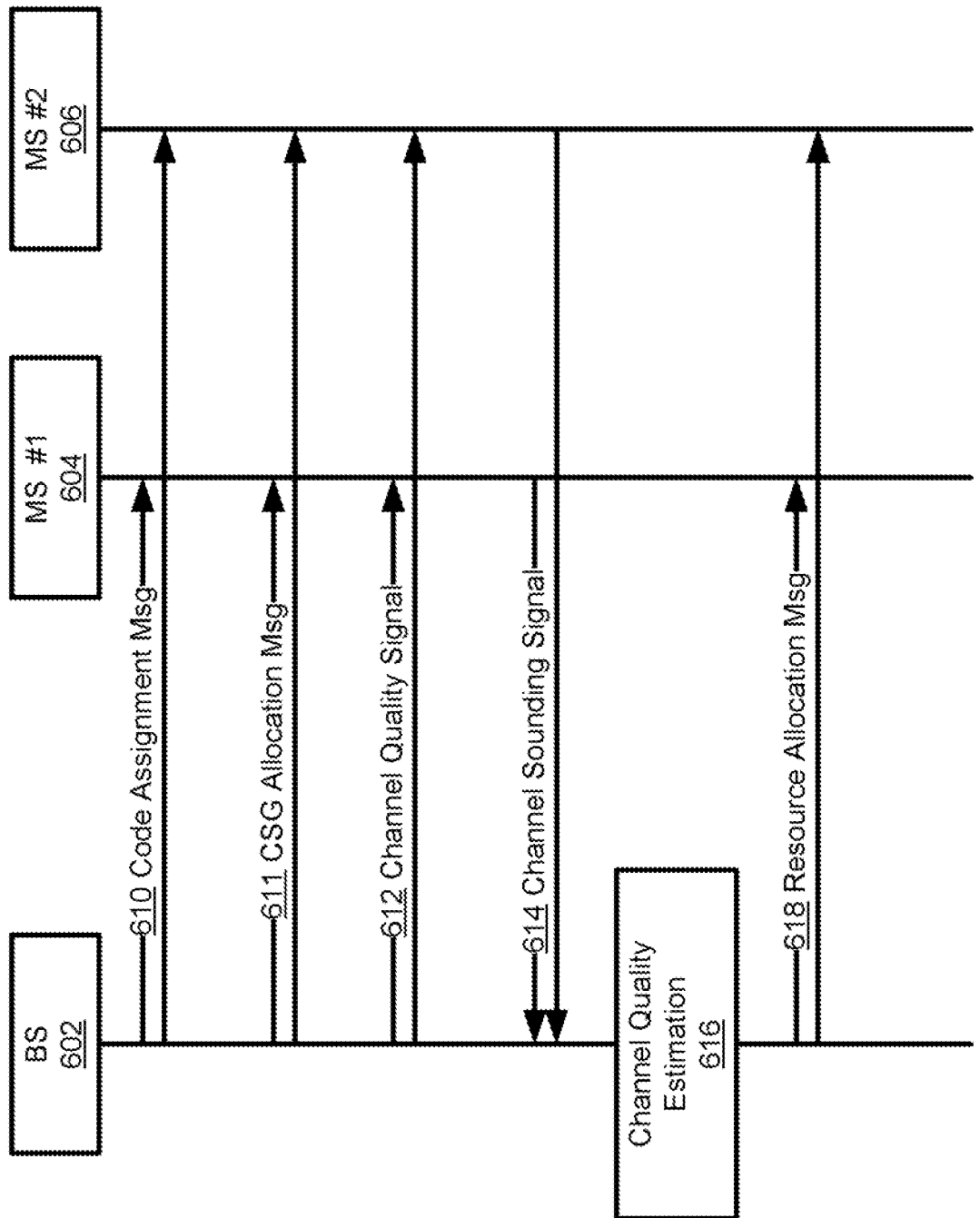


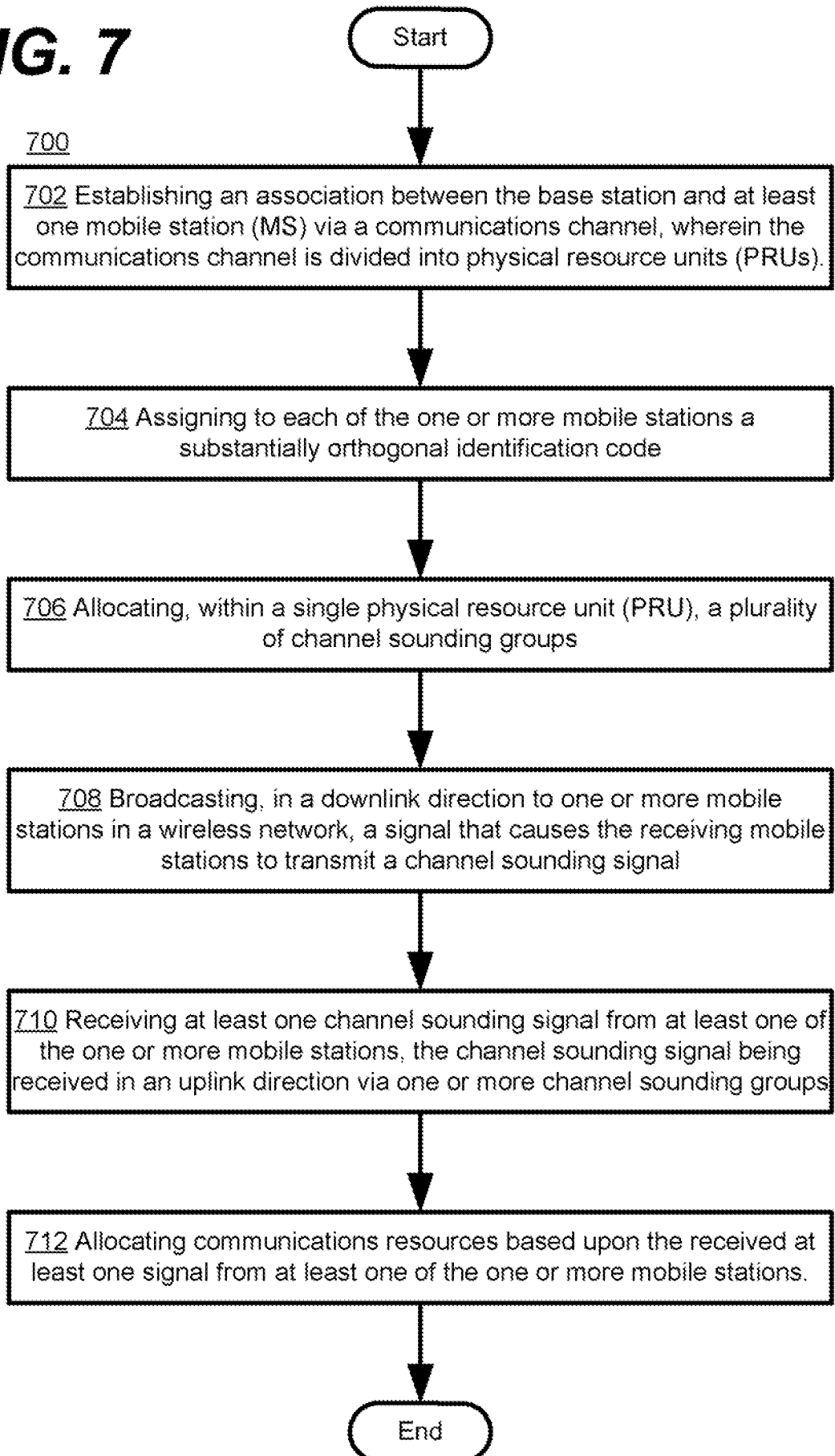
# FIG. 5

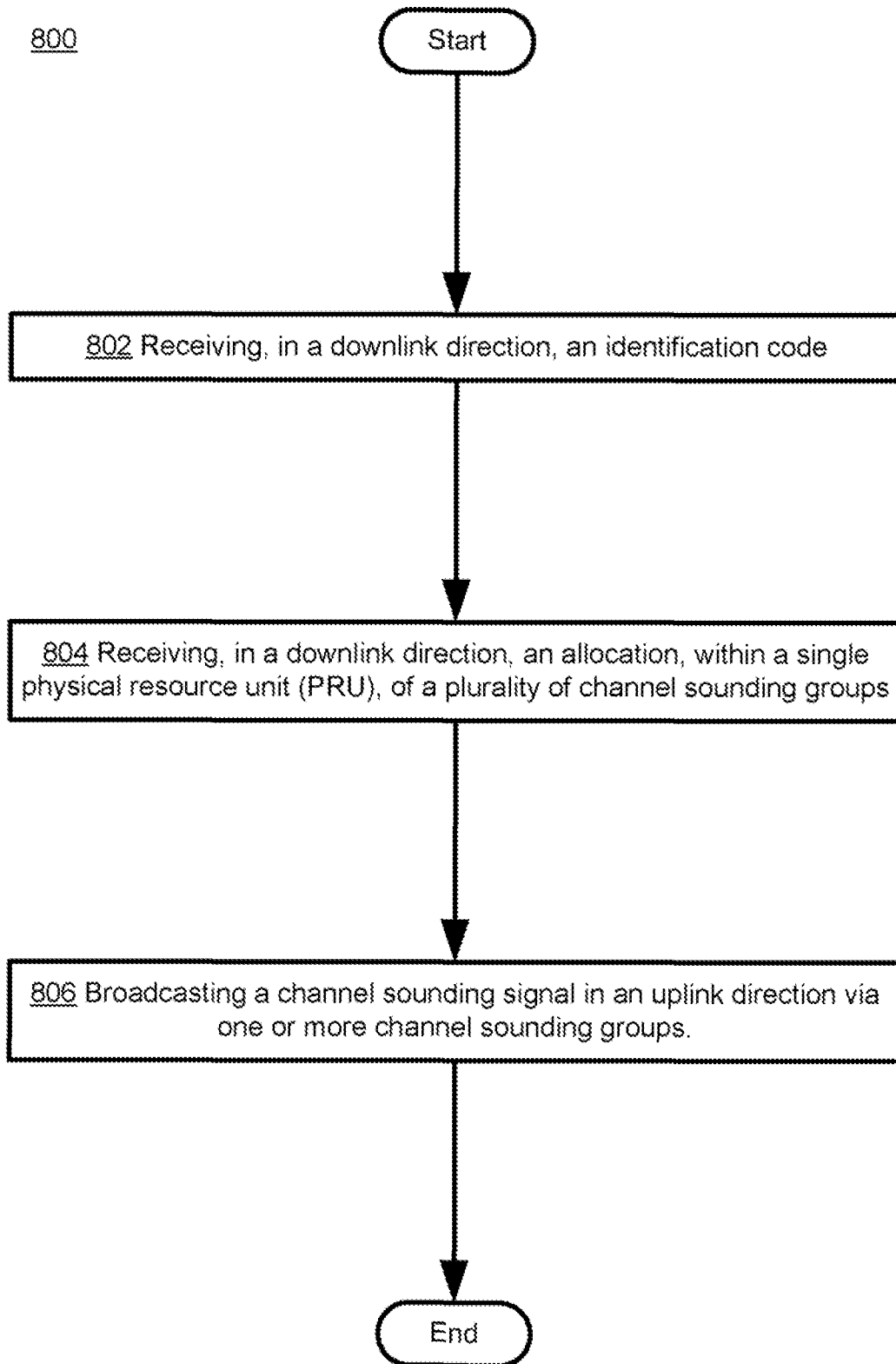


**FIG. 6**

600



**FIG. 7**

**FIG. 8**

# INTERNATIONAL SEARCH REPORT

International application No  
PCT/EP2009/062571

<b>A. CLASSIFICATION OF SUBJECT MATTER</b> INV. H04L5/00				
According to International Patent Classification (IPC) or to both national classification and IPC				
<b>B. FIELDS SEARCHED</b>				
Minimum documentation searched (classification system followed by classification symbols) H04L				
Documentation searched other than minimum documentation to the extent that such documents are included in the fields searched				
Electronic data base consulted during the international search (name of data base and, where practical, search terms used) EPO-Internal				
<b>C. DOCUMENTS CONSIDERED TO BE RELEVANT</b>				
Category*	Citation of document, with indication, where appropriate, of the relevant passages	Relevant to claim No.		
X	WO 2008/086110 A (QUALCOMM INC [US]; BUDIANU PETRU CRISTIAN [US]; GORE DHANANJAY ASHOK [ ] 17 July 2008 (2008-07-17) paragraph [0024] - paragraph [0040] paragraph [0052] paragraph [0067] figures 3A-3D	1-25		
A	US 2007/189408 A1 (WAXMAN SHAI [IL]) 16 August 2007 (2007-08-16) paragraph [0039]	1-25		
----- -/--				
<input checked="" type="checkbox"/> Further documents are listed in the continuation of Box C.				
<input checked="" type="checkbox"/> See patent family annex.				
* Special categories of cited documents :				
<table style="width: 100%; border: none;"> <tr> <td style="width: 50%; border: none; vertical-align: top;">                     *A* document defining the general state of the art which is not considered to be of particular relevance                      *E* earlier document but published on or after the international filing date                      *L* document which may throw doubts on priority claim(s) or which is cited to establish the publication date of another citation or other special reason (as specified)                      *O* document referring to an oral disclosure, use, exhibition or other means                      *P* document published prior to the international filing date but later than the priority date claimed                 </td> <td style="width: 50%; border: none; vertical-align: top;">                     *T* later document published after the international filing date or priority date and not in conflict with the application but cited to understand the principle or theory underlying the invention                      *X* document of particular relevance; the claimed invention cannot be considered novel or cannot be considered to involve an inventive step when the document is taken alone                      *Y* document of particular relevance; the claimed invention cannot be considered to involve an inventive step when the document is combined with one or more other such documents, such combination being obvious to a person skilled in the art.                      *&amp;* document member of the same patent family                 </td> </tr> </table>			*A* document defining the general state of the art which is not considered to be of particular relevance *E* earlier document but published on or after the international filing date *L* document which may throw doubts on priority claim(s) or which is cited to establish the publication date of another citation or other special reason (as specified) *O* document referring to an oral disclosure, use, exhibition or other means *P* document published prior to the international filing date but later than the priority date claimed	*T* later document published after the international filing date or priority date and not in conflict with the application but cited to understand the principle or theory underlying the invention *X* document of particular relevance; the claimed invention cannot be considered novel or cannot be considered to involve an inventive step when the document is taken alone *Y* document of particular relevance; the claimed invention cannot be considered to involve an inventive step when the document is combined with one or more other such documents, such combination being obvious to a person skilled in the art. *&* document member of the same patent family
*A* document defining the general state of the art which is not considered to be of particular relevance *E* earlier document but published on or after the international filing date *L* document which may throw doubts on priority claim(s) or which is cited to establish the publication date of another citation or other special reason (as specified) *O* document referring to an oral disclosure, use, exhibition or other means *P* document published prior to the international filing date but later than the priority date claimed	*T* later document published after the international filing date or priority date and not in conflict with the application but cited to understand the principle or theory underlying the invention *X* document of particular relevance; the claimed invention cannot be considered novel or cannot be considered to involve an inventive step when the document is taken alone *Y* document of particular relevance; the claimed invention cannot be considered to involve an inventive step when the document is combined with one or more other such documents, such combination being obvious to a person skilled in the art. *&* document member of the same patent family			
Date of the actual completion of the international search  <p style="text-align: center; font-size: 1.2em;">13 January 2010</p>		Date of mailing of the international search report  <p style="text-align: center; font-size: 1.2em;">21/01/2010</p>		
Name and mailing address of the ISA/ European Patent Office, P.B. 5818 Patentlaan 2 NL - 2280 HV Rijswijk Tel. (+31-70) 340-2040, Fax: (+31-70) 340-3016		Authorized officer  <p style="text-align: center; font-size: 1.2em;">Baltersee, Jens</p>		

# INTERNATIONAL SEARCH REPORT

International application No  
PCT/EP2009/062571

C(Continuation). DOCUMENTS CONSIDERED TO BE RELEVANT		
Category*	Citation of document, with indication, where appropriate, of the relevant passages	Relevant to claim No.
A	<p>FRANK HSIEH ET AL: "PHY 44-2 - Link Performance of WiMAX PUSC"                      WIRELESS COMMUNICATIONS AND NETWORKING CONFERENCE, 2008. WCNC 2008. IEEE, IEEE, PISCATAWAY, NJ, USA,                      31 March 2008 (2008-03-31), pages 1143-1148, XP031243791                      ISBN: 978-1-4244-1997-5                      page 1146, right-hand column, Section V, penultimate paragraph                      -----</p>	1-25

# INTERNATIONAL SEARCH REPORT

Information on patent family members

International application No

PCT/EP2009/062571

Patent document cited in search report	Publication date	Patent family member(s)	Publication date
WO 2008086110 A	17-07-2008	CA 2672318 A1	17-07-2008
		CN 101578836 A	11-11-2009
		EP 2100423 A2	16-09-2009
		US 2008165891 A1	10-07-2008
-----			
US 2007189408 A1	16-08-2007	CN 101371460 A	18-02-2009
		EP 1992082 A1	19-11-2008
		WO 2007095290 A1	23-08-2007
-----			