

Nov. 10, 1931.

E. DIXON

1,831,231

TOP ROLL SADDLE

Filed Sept. 10, 1930

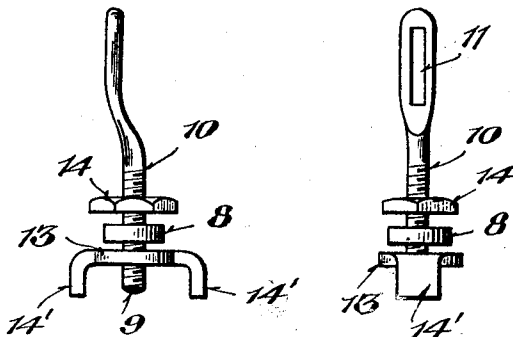
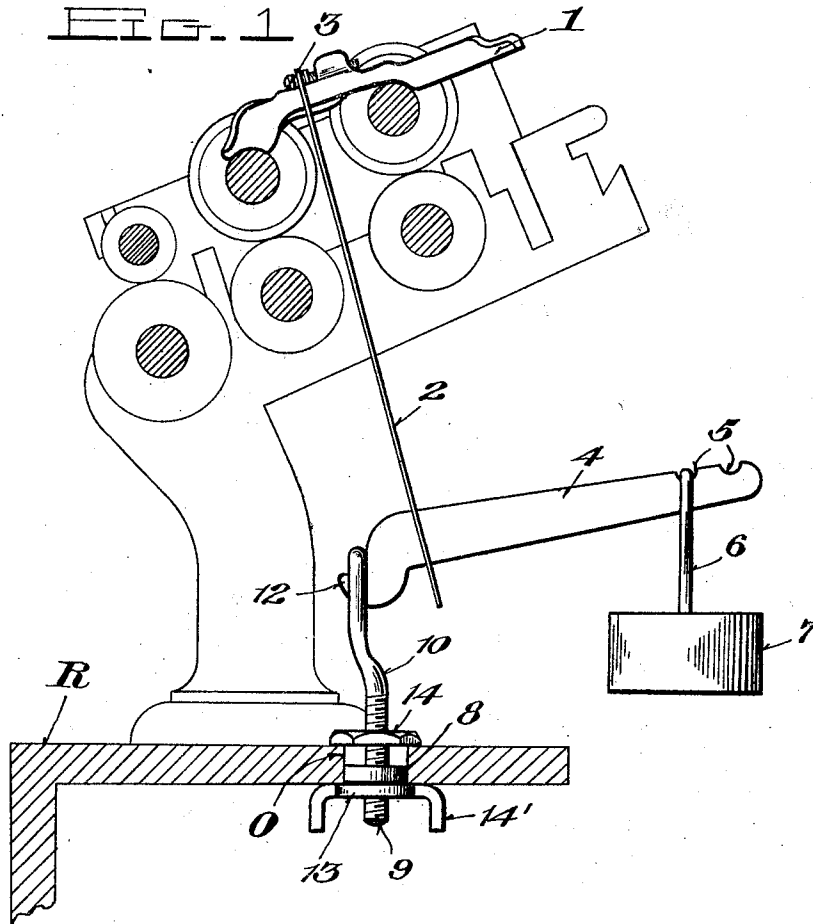

INVENTOR.  
*Ezra Dixon*  
BY *Joseph A. Miller*  
ATTORNEYS.

# UNITED STATES PATENT OFFICE

EZRA DIXON, OF BRISTOL, RHODE ISLAND, ASSIGNOR TO DIXON LUBRICATING SADDLE COMPANY, OF BRISTOL, RHODE ISLAND

## TOP ROLL SADDLE

Application filed September 10, 1930. Serial No. 480,907.

This invention relates to certain new and useful improvements in top roll saddles and the primary object thereof is to provide a construction in which textile machines of a certain type, which have been abandoned owing to the uncertainty of action of the weights for tensioning the saddle, can be reclaimed and again put into use and operation.

In a certain class of machines it has been the practice to provide a hole in the top rail of the drawing frame through which extended a weight carrying member, with the weight disposed beneath the top rail. This method of tensioning the top saddle has proven to be objectionable owing to the uncertainty of the action of the weights, and accordingly a large number of these machines otherwise free of objection, have been abandoned. The present invention therefore aims to provide a construction in which the aforementioned use of the perforation of the top rail is discarded or eliminated, and a construction otherwise provided wherein the action of the weight is definite and certain and overcomes the objections above noted.

In the drawings:—

Figure 1 is a side elevation, partly broken away and in section showing the present invention applied to a machine of the type referred to;

Figure 2 is a side elevation of the lever supporting member removed from the machine; and

Figure 3 is a front elevation of Figure 2. The top roll saddle 1 may be of any desired form and has depending therefrom a rod or connection 2 which latter is adjustably connected at 3 to the saddle 1 and depends therefrom, the rod having its lower end engaged with a lever 4, provided with notches 5 to selectively receive the usual hook 6 of the weight 7. The lever 4 it will be noted is disposed above the top of the top rail R and the weight preferably is also so disposed. A washer or centering plug 8 of a size to fit the opening O, of the type of machine above referred to, is fitted in said opening and has a threaded central perforation to receive the threaded end 9 of a post 10, the post having its upper end provided with an elongated

aperture 11 to receive therethrough the rear end of the lever 4 and to thus provide a fulcrum about which the lever may move. A lower nut 13 provided with operating fingers 14' is threaded on the end 9 of the stem 10, while a nut 14 is also threaded on the stem and seats against the upper face of the top rail R. The nut 13 is driven against the underface of the rail R so as to rigidly clamp the stem or post 10 in vertical position. Obviously by adjustment of the nut 14 the stem may be positioned so as to vary the height of the fulcrum of lever 4 as may be desired or found necessary.

From the foregoing it will be seen that by the provision of the present invention, machines of the type referred to may be readily reclaimed and again put into operation, and with certainty of action of the weight, the entire pressure creating means for the saddle being disposed wholly above the top rail, thus overcoming the objections of the above mentioned prior practice in the art wherein the weight carrying member extends through the opening O, and with the weight disposed at a distance below the top rail R.

Having thus described my invention what I claim as new and desire to secure by Letters Patent is:—

1. A top roll saddle device composed of a member formed to be fitted in the opening in the top rail of a textile machine and having a threaded opening, a stem threaded at its lower end through said opening and having an apertured upper end, nuts on the stem to engage opposite faces of the top rail so as to rigidly clamp the stem in vertical position to project above the top rail, a lever having its rear end extending freely through the aperture of the upper end of the machine, a weight carried by the front end of the lever, and means to connect the lever to a top roll saddle.

2. A top roll saddle device composed of a member formed to be fitted in the opening in the top rail of a textile machine and having a threaded opening, a stem threaded at its lower end through said opening, means on the stem engaging opposite faces of the rail to clamp same to the rail, so as to project

the stem above the rail, a lever fulcrumed on the stem, a weight carried by the lever, and means to connect the lever to the saddle.

3 A top roll saddle device including a centering member formed to be conformably  
5 fitted in an opening in the top rail of a textile machine, and having an opening there-  
through, a stem having a threaded part extending through said opening of said mem-  
10 ber, a pair of means each threaded on the stem and engaging the respective opposite  
faces of the rail to hold the stem against vertical movements, a lever fulcrumed on the  
stem, a weight carried by the lever and  
15 means to connect the lever to a top roll saddle.

4. A top roll saddle device for use with textile machines having an opening in the  
top rail thereof, including centering means  
20 disposed in said opening and having an aperture therethrough, a stem extending through  
said aperture of the centering means, means on the stem disposed above and below the  
top rail and engaged with the respective  
25 upper and lower faces thereof for clamping the stem to the rail in various vertical ad-  
justed positions of the stem, a lever fulcrumed on the stem, a weight carried by the  
lever, and means to connect the lever to a  
30 top roll saddle.

In testimony whereof I have signed my name to this specification.

EZRA DIXON.

35

40

45

50

55

60

65