

(19) World Intellectual Property Organization
International Bureau



(43) International Publication Date
11 January 2001 (11.01.2001)

PCT

(10) International Publication Number
WO 01/02178 A1

- (51) International Patent Classification⁷: **B41J 2/045**
- (21) International Application Number: PCT/AU00/00584
- (22) International Filing Date: 24 May 2000 (24.05.2000)
- (25) Filing Language: English
- (26) Publication Language: English
- (30) Priority Data:
PQ1309 30 June 1999 (30.06.1999) AU
- (71) Applicant (for all designated States except US): **SILVERBROOK RESEARCH PTY LTD** [AU/AU]; 393 Darling Street, Balmain, NSW 2041 (AU).
- (72) Inventor; and
- (75) Inventor/Applicant (for US only): **SILVERBROOK, Kia** [AU/AU]; Silverbrook Research Pty Ltd, 393 Darling Street, Balmain, NSW 2041 (AU).
- (81) Designated States (national): AE, AG, AL, AM, AT, AU, AZ, BA, BB, BG, BR, BY, CA, CH, CN, CR, CU, CZ, DE, DK, DM, DZ, EE, ES, FI, GB, GD, GE, GH, GM, HR, HU, ID, IL, IN, IS, JP, KE, KG, KP, KR, KZ, LC, LK, LR, LS, LT, LU, LV, MA, MD, MG, MK, MN, MW, MX, MZ, NO, NZ, PL, PT, RO, RU, SD, SE, SG, SI, SK, SL, TJ, TM, TR, TT, TZ, UA, UG, US, UZ, VN, YU, ZA, ZW.
- (84) Designated States (regional): ARIPO patent (GH, GM, KE, LS, MW, MZ, SD, SL, SZ, TZ, UG, ZW), Eurasian patent (AM, AZ, BY, KG, KZ, MD, RU, TJ, TM), European patent (AT, BE, CH, CY, DE, DK, ES, FI, FR, GB, GR, IE, IT, LU, MC, NL, PT, SE), OAPI patent (BF, BJ, CF, CG, CI, CM, GA, GN, GW, ML, MR, NE, SN, TD, TG).
- Published:**
— With international search report.
- For two-letter codes and other abbreviations, refer to the "Guidance Notes on Codes and Abbreviations" appearing at the beginning of each regular issue of the PCT Gazette.

(54) Title: CALIBRATING A MICRO ELECTRO-MECHANICAL DEVICE

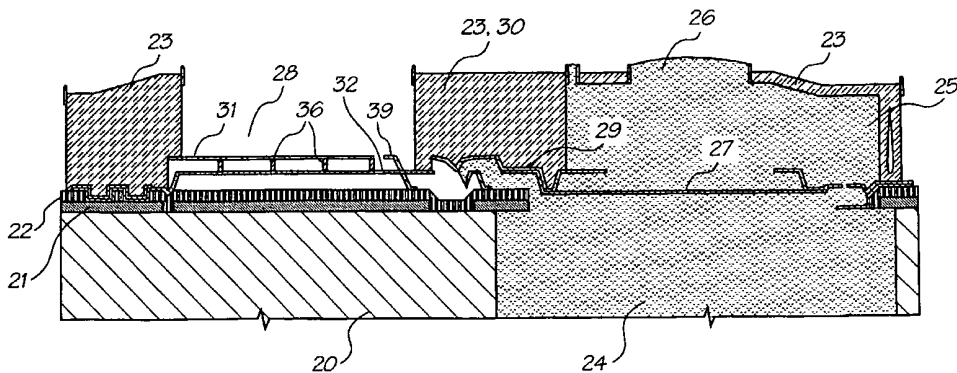

(57) Abstract: A method of calibrating a micro electro-mechanical device in the form of an ink ejection nozzle having an actuating arm that is caused to move an ink displacing paddle when heat inducing electric current is passed through the actuating arm and having also a movement sensor associated with the actuating arm. The method comprises the steps of passing a series of current pulses of successively increasing duration t_p through the actuating arm over a time period t , detecting for a predetermined level of movement of the actuating arm within a predetermined time window t_w , and calibrating the device for subsequent actuation by a current pulse having a duration t_p sufficient to produce the predetermined level of movement within the predetermined time window t_w .

WO 01/02178 A1

CALIBRATING A MICRO ELECTRO-MECHANICAL DEVICE**FIELD OF THE INVENTION**

This invention relates to a method of calibrating a micro electro-mechanical (MEM) device. The invention has application in ink ejection nozzles of the type that are fabricated by integrating the technologies applicable to micro electro-mechanical system (MEMS) and complementary metal-oxide semiconductor (CMOS) integrated circuits, and the invention is hereinafter described in the context of that application. However, it will be understood that the invention does have broader application, to the calibration of various types of MEM devices for various purposes.

CO-PENDING APPLICATIONS

Various methods, systems and apparatus relating to the present invention are disclosed in the following co-pending applications filed by the applicant or assignee of the present invention simultaneously with the present application:

PCT/AU00/00518, PCT/AU00/00519, PCT/AU00/00520, PCT/AU00/00521,
PCT/AU00/00522, PCT/AU00/00523, PCT/AU00/00524, PCT/AU00/00525,
PCT/AU00/00526, PCT/AU00/00527, PCT/AU00/00528, PCT/AU00/00529,
PCT/AU00/00530, PCT/AU00/00531, PCT/AU00/00532, PCT/AU00/00533,
PCT/AU00/00534, PCT/AU00/00535, PCT/AU00/00536, PCT/AU00/00537,
PCT/AU00/00538, PCT/AU00/00539, PCT/AU00/00540, PCT/AU00/00541,
PCT/AU00/00542, PCT/AU00/00543, PCT/AU00/00544, PCT/AU00/00545,
PCT/AU00/00547, PCT/AU00/00546, PCT/AU00/00554, PCT/AU00/00556,
PCT/AU00/00557, PCT/AU00/00558, PCT/AU00/00559, PCT/AU00/00560,
PCT/AU00/00561, PCT/AU00/00562, PCT/AU00/00563, PCT/AU00/00564,
PCT/AU00/00565, PCT/AU00/00566, PCT/AU00/00567, PCT/AU00/00568,
PCT/AU00/00569, PCT/AU00/00570, PCT/AU00/00571, PCT/AU00/00572,
PCT/AU00/00573, PCT/AU00/00574, PCT/AU00/00575, PCT/AU00/00576,
PCT/AU00/00577, PCT/AU00/00578, PCT/AU00/00579, PCT/AU00/00581,
PCT/AU00/00580, PCT/AU00/00582, PCT/AU00/00587, PCT/AU00/00588,
PCT/AU00/00589, PCT/AU00/00583, PCT/AU00/00593, PCT/AU00/00590,

- la -

PCT/AU00/00591, PCT/AU00/00592, PCT/AU00/00584, PCT/AU00/00585,
PCT/AU00/00586, PCT/AU00/00594, PCT/AU00/00595, PCT/AU00/00596,
PCT/AU00/00597, PCT/AU00/00598, PCT/AU00/00516, PCT/AU00/00517,
PCT/AU00/00511, PCT/AU00/00501, PCT/AU00/00502, PCT/AU00/00503,
5 PCT/AU00/00504, PCT/AU00/00505, PCT/AU00/00506, PCT/AU00/00507,
PCT/AU00/00508, PCT/AU00/00509, PCT/AU00/00510, PCT/AU00/00512,
PCT/AU00/00513, PCT/AU00/00514, PCT/AU00/00515

The disclosures of these co-pending applications are incorporated herein by cross-reference.

10

BACKGROUND OF THE INVENTION

A high speed pagewidth inkjet printer has recently been developed by the present Applicant. This typically employs in the order of 51200 inkjet nozzles to print on A4 size paper to provide photographic quality image printing at 1600 dpi. In order to achieve this

- 2 -

paper to provide photographic quality image printing at 1600 dpi. In order to achieve this nozzle density, the nozzles are fabricated by integrating MEMS-CMOS technology.

A difficulty that flows from the fabrication of such a printer is that there is no convenient way of ensuring that all nozzles that extend across the printhead or, indeed, that
5 are located on a given chip will perform identically, and this problem is exacerbated when chips that are obtained from different wafers may need to be assembled into a given printhead. Also, having fabricated a complete printhead from a plurality of chips, it is difficult to determine the energy level required for actuating individual nozzles and for evaluating the continuing performance of a given nozzle.

10

SUMMARY OF THE INVENTION

The present invention may be defined broadly as providing a method of calibrating a micro electro-mechanical device of a type having a support structure, an actuating arm that is movable relative to the support structure under the influence of heat inducing current
15 flow through the arm and a movement sensor associated with the actuating arm. The method comprises the steps of:

- (a) passing a series of current pulses of successively increasing duration t_p through the actuating arm (so as to induce successively increasing degrees of movement of the actuating arm) over a time period t ,
- 20 (b) detecting for a predetermined level of movement of the actuating arm within a predetermined time window t_w where $t > t_w > t_p$, and
- (c) Calibrating the device for subsequent actuation of the actuating arm by a current pulse having a duration t_p sufficient to produce the predetermined level of movement within the predetermined time window t_w .

25 The above defined method permits the calibration of a single micro electro-mechanical (MEM) device and, more importantly, permits the calibration of each device within an array of the devices, so that all of the devices within the array will function in a substantially uniform manner.

- 3 -

PREFERRED FEATURES OF THE INVENTION

The calibration method of the invention preferably is employed in relation to an MEM device in the form of a liquid ejector and most preferably in the form of an ink ejection nozzle that is operable to eject an ink droplet upon actuation of the actuating arm.

5 In this latter preferred form of the invention, the second end of the actuating arm preferably is coupled to an integrally formed paddle which is employed to displace ink from a chamber into which the actuating arm extends.

The actuating arm most preferably is formed from two similarly shaped arm portions which are interconnected in interlapping relationship. In this embodiment of the invention, a first of the arm portions is connected to a current supply and is arranged in use to be heated by the current pulses having duration t_p . However, the second arm portion functions to restrain linear expansion of the actuating arm as a complete unit and heat induced elongation of the first arm portion causes bending to occur along the length of the actuating arm. Thus, the actuating arm is effectively caused to pivot with respect to the support structure with heating and cooling of the first portion of the actuating arm.

15 The invention will be more fully understood from the following description of a preferred embodiment of a calibration method as applied to an inkjet nozzle as illustrated in the accompanying drawings.

20 BRIEF DESCRIPTION OF THE DRAWINGS

In the drawings:-

Figure 1 shows a highly magnified cross-sectional elevation view of a portion of the inkjet nozzle,

Figure 2 shows a plan view of the inkjet nozzle of Figure 1,

25 Figure 3 shows a perspective view of an outer portion of an actuating arm and an ink ejecting paddle or of the inkjet nozzle, the actuating arm and paddle being illustrated independently of other elements of the nozzle,

Figure 4 shows an arrangement similar to that of Figure 3 but in respect of an inner portion of the actuating arm,

30 Figure 5 shows an arrangement similar to that of Figures 3 and 4 but in respect of the complete actuating arm incorporating the outer and inner portions shown in Figures 3 and 4,

Figure 6 shows a detailed portion of a movement sensor arrangement that is shown

- 4 -

encircled in Figure 5,

Figure 7 shows a sectional elevation view of the nozzle of Figure 1 but prior to charging with ink,

Figure 8 shows a sectional elevation view of the nozzle of Figure 7 but with the actuating arm and paddle actuated to a calibration position,

Figure 9 shows ink ejection from the nozzle when actuated under a calibration condition,

Figure 10 shows a blocked condition of the nozzle when the actuating arm and paddle are actuated to an extent that normally would be sufficient to eject ink from the nozzle,

Figure 11 shows a schematic representation of a portion of an electrical circuit that is embodied within the nozzle,

Figure 12 shows an excitation-time diagram applicable to normal (ink ejecting) actuation of the nozzle actuating arm,

Figure 13 shows an excitation-time diagram applicable to calibration actuation of the nozzle actuating arm,

Figure 14 shows comparative displacement-time curves applicable to the excitation-time diagrams shown in Figures 12 and 13,

Figure 15 shows an excitation-time diagram applicable to a calibration procedure,

Figure 16 shows a temperature-time diagram that is applicable to the nozzle actuating arm and which corresponds with the excitation-time diagram of Figure 15, and

Figure 17 shows a deflection-time diagram that is applicable to the nozzle actuating arm and which corresponds with the excitation/heating-time diagrams of Figures 15 and 16.

DETAILED DESCRIPTION OF THE INVENTION

As illustrated with approximately 3000x magnification in Figure 1 and other relevant drawing figures, a single inkjet nozzle device is shown as a portion of a chip that is fabricated by integrating MEMS and CMOS technologies. The complete nozzle device includes a support structure having a silicon substrate 20, a metal oxide semiconductor layer 21, a passivation layer 22, and a non-corrosive dielectric coating/chamber-defining layer 23.

The nozzle device incorporates an ink chamber 24 which is connected to a source

- 5 -

(not shown) of ink and, located above the chamber, a nozzle chamber 25. A nozzle opening 26 is provided in the chamber-defining layer 23 to permit displacement of ink droplets toward paper or other medium (not shown) onto which ink is to be deposited. A paddle 27 is located between the two chambers 24 and 25 and, when in its quiescent position, as indicated in Figures 1 and 7, the paddle 27 effectively divides the two chambers 24 and 25.

The paddle 27 is coupled to an actuating arm 28 by a paddle extension 29 and a bridging portion 30 of the dielectric coating 23.

The actuating arm 28 is formed (i.e. deposited during fabrication of the device) to be pivotable with respect to the support structure or substrate 20. That is, the actuating arm has a first end that is coupled to the support structure and a second end 38 that is movable outwardly with respect to the support structure. The actuating arm 28 comprises outer and inner arm portions 31 and 32. The outer arm portion 31 is illustrated in detail and in isolation from other components of the nozzle device in the perspective view shown in Figure 3. The inner arm portion 32 is illustrated in a similar way in Figure 4. The complete actuating arm 28 is illustrated in perspective in Figure 5, as well as in Figures 1, 7, 8, 9 and 10.

The inner portion 32 of the actuating arm 28 is formed from a titanium-aluminium-nitride (TiAl)N, deposit during formation of the nozzle device and it is connected electrically to a current source 33, as illustrated schematically in Figure 11, within the CMOS structure. The electrical connection is made to end terminals 34 and 35, and application of a pulsed excitation voltage to the terminals results in pulsed current flow through the inner portion only of the actuating arm 28. The current flow causes rapid resistance heating within the inner portion 32 of the actuating arm and consequential elongation of that portion of the arm.

The outer arm portion 31 of the actuating arm 28 is mechanically coupled to but electrically isolated from the inner arm portion 32 by posts 36. No current-induced heating occurs within the outer arm portion 31 and, as a consequence, voltage induced current flow through the inner arm portion 32 causes momentary bending of the complete actuating arm 28 in the manner indicated in Figures 8, 9 and 10 of the drawings. This bending of the actuating arm 28 is equivalent to pivotal movement of the arm with respect to the substrate 20 and it results in displacement of the paddle 27 within the chambers 24 and 25.

An integrated movement sensor is provided within the device in order to determine the degree or rate of pivotal movement of the actuating arm 28 and in order to permit

- 6 -

calibration of the device.

The movement sensor comprises a moving contact element 37 that is formed integrally with the inner portion 32 of the actuating arm 28 and which is electrically active when current is passing through the inner portion of the actuating arm. The moving contact element 37 is positioned adjacent the second end 38 of the actuating arm and, thus, with a voltage V applied to the end terminals 34 and 35, the moving contact element will be at a potential of approximately $V/2$. The movement sensor also comprises a fixed contact element 39 which is formed integrally with the CMOS layer 22 and which is positioned to be contacted by the moving contact element 37 when the actuating arm 28 pivots upwardly to a predetermined extent. The fixed contact element is connected electrically to amplifier elements 40 and to a microprocessor arrangement 41, both of which are shown in Figure 11 and the component elements of which are embodied within the CMOS layer 22 of the device.

When the actuator arm 28 and, hence, the paddle 27 are in the quiescent position, as shown in Figures 1 and 7, no contact is made between the moving and fixed contact elements 37 and 39. At the other extreme, when excess movement of the actuator arm and the paddle occurs, as indicated in Figures 8 and 9, contact is made between the moving and fixed contact elements 37 and 39. When the actuator arm 28 and the paddle 27 are actuated to a normal extent sufficient to expel ink from the nozzle, no contact is made between the moving and fixed contact elements. That is, with normal ejection of the ink from the chamber 25, the actuator arm 28 and the paddle 27 are moved to a position partway between the positions that are illustrated in Figures 7 and 8. This (intermediate) position is indicated in Figure 10, although as a consequence of a blocked nozzle rather than during normal ejection of ink from the nozzle.

Figure 12 shows an excitation-time diagram that is applicable to effecting actuation of the actuator arm 28 and the paddle 27 from a quiescent to a lower-than-normal ink ejecting position. The displacement of the paddle 27 resulting from the excitation of Figure 12 is indicated by the lower graph 42 in Figure 14, and it can be seen that the maximum extent of displacement is less than the optimum level that is shown by the displacement line 43.

Figure 13 shows an expanded excitation-time diagram that is applicable to effecting actuation of the actuator arm 28 and the paddle 27 to an excessive extent, such as is indicated in Figures 8 and 9. The displacement of the paddle 27 resulting from the

- 7 -

excitation of Figure 13 is indicated by the upper graph 44 in Figure 14, from which it can be seen that the maximum displacement level is greater than the optimum level indicated by the displacement line 43.

Figures 15, 16 and 17 shows plots of excitation voltage, actuator arm temperature and paddle deflection against time for successively increasing durations of excitation applied to the actuating arm 28. These plots have relevance to calibration of the nozzle device.

When calibrating the nozzle device, or each device in an array of the nozzle devices, a series of current pulses of successively increasing duration t_p are induced to flow through the actuating arm 28 over a time period t . The duration t_p is controlled to increase as:

$$t_{pi}, t_{pi}+\Delta t_{pi}, t_{pi}+2\Delta t_{pi}, \dots$$

Each current pulse induces momentary heating in the actuating arm and a consequential temperature rise occurs, followed by a temperature fall on expiration of the pulse duration. As indicated in Figure 16, the temperature rises to successively higher levels with the increasing pulse durations as indicated in Figure 15.

As a result, as indicated in Figure 17, the actuator arm 27 will move (i.e. pivot) to successively increasing degrees, some of which will be below that required to cause contact to be made between the moving and fixed contact elements 37 and 39 and others of which will be above that required to cause contact to be made between the moving and fixed contact elements. This is indicated by the "calibration level" line shown in Figure 17.

The microprocessor 41 is employed to detect for a predetermined level of movement of the actuating arm (i.e. the "calibration level") within a predetermined time window t_w that falls within the calibration time t . This is then correlated with the particular pulse duration t_p that induces the required movement within the time window, and that pulse duration is then employed for subsequent actuation of the device.

Variations and modifications may be made in respect of the device as described above as a preferred embodiment of the invention without departing from the scope of the appended claims.

- 8 -

I claim:

1. A method of calibrating a micro electro-mechanical device of a type having a support structure, an actuating arm that is movable relative to the support structure under the influence of heat inducing current flow through the arm and a movement sensor associated with the actuating arm; the method comprising the steps of:
 - (a) passing a series of current pulses of varying duration t_p through the actuating arm (so as to induce varying degrees of movement of the actuating arm) over a time period t ,
 - (b) detecting for a predetermined level of movement of the actuating arm within a predetermined time window t_w where $t > t_w > t_p$, and
 - (c) calibrating the device for subsequent actuation of the actuating arm by a current pulse having a duration t_p sufficient to produce the predetermined level of movement within the predetermined time window t_w .
2. The method as claimed in claim 1 when employed in relation to a liquid ejection nozzle having a liquid receiving chamber from which the liquid is ejected with movement of the actuating arm.
3. The method as claimed in claim 1 when employed in relation to an ink ejection nozzle having an ink receiving chamber from which the ink is ejected with movement of the actuating arm.
4. The method as claimed in claim 3 wherein the movement sensor comprises a moving contact element formed integrally with the actuating arm, a fixed contact element formed integrally with the support structure and electric circuit elements formed within the support structure, and wherein the predetermined level of movement of the actuating arm is detected by contact made between the fixed and moving contact elements.
5. The method as claimed in claim 4 wherein the movement sensor includes a microprocessor and wherein the microprocessor detects for the predetermined level of movement of the actuating arm within the predetermined time window t_w

- 9 -

and correlates the predetermined level of movement with a pulse duration t_p that induces the predetermined level of movement within the time window t_w .

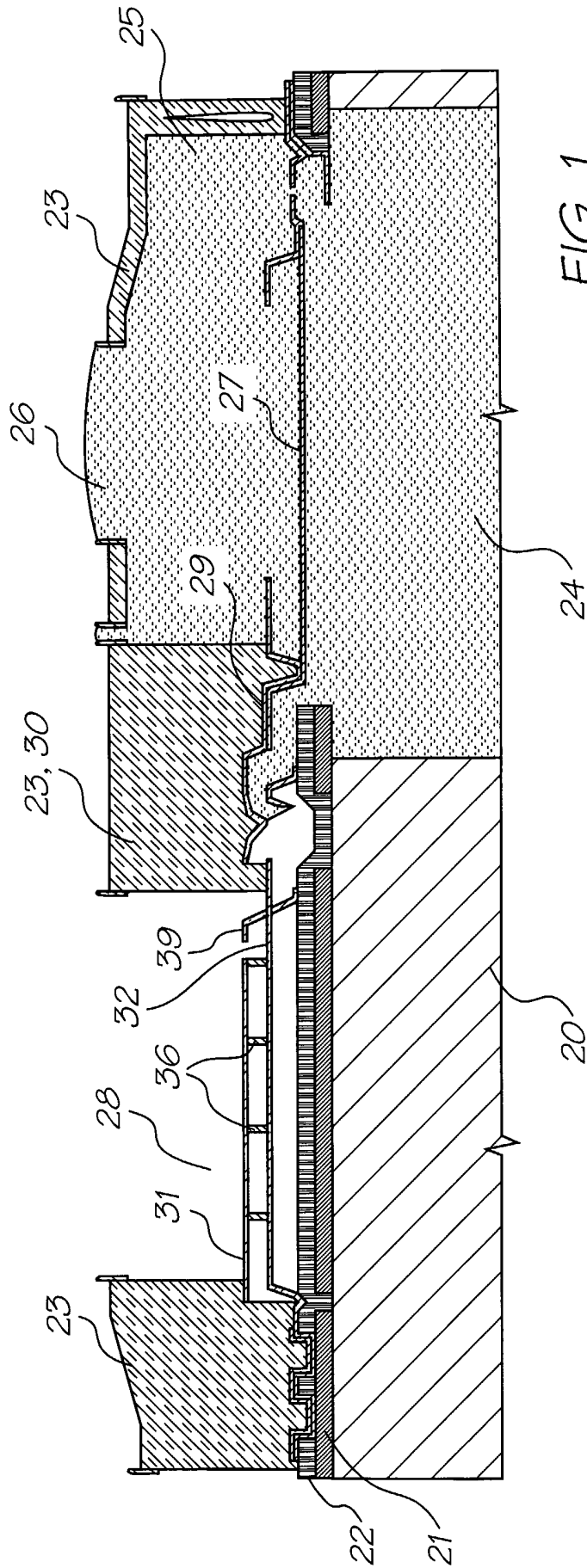

FIG. 1

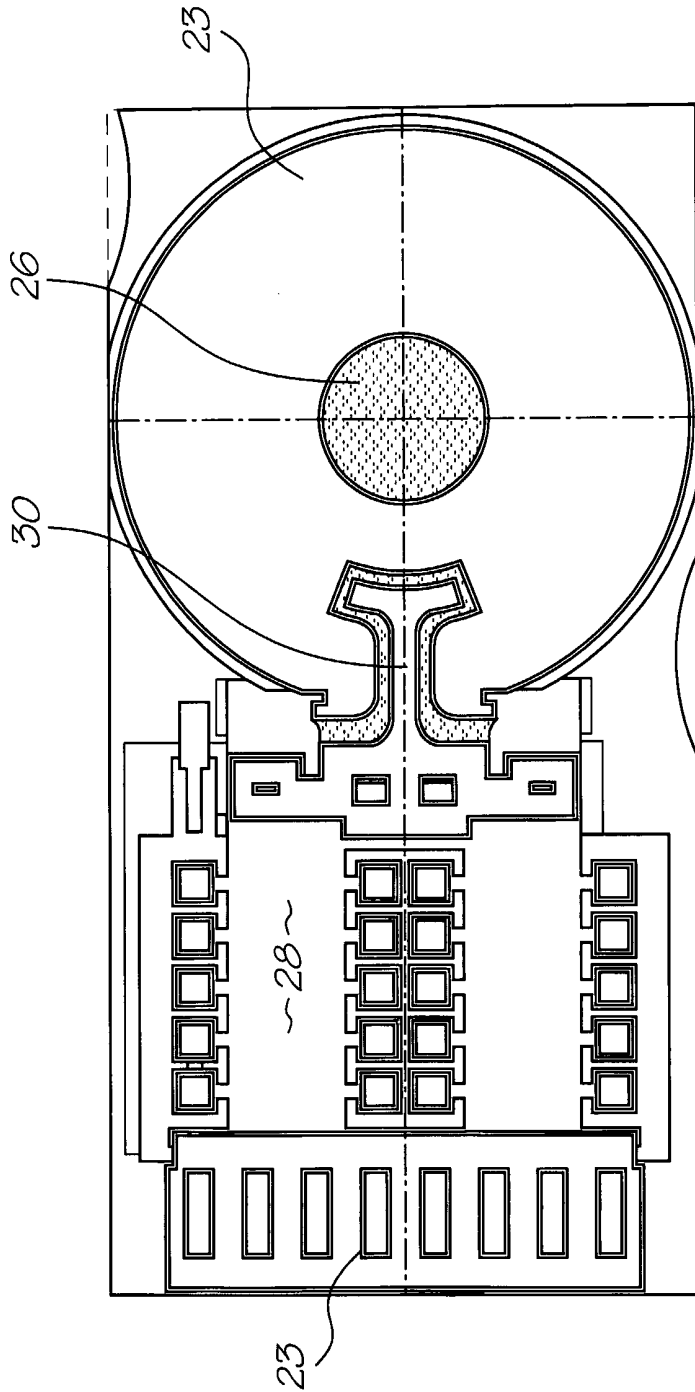

FIG. 2

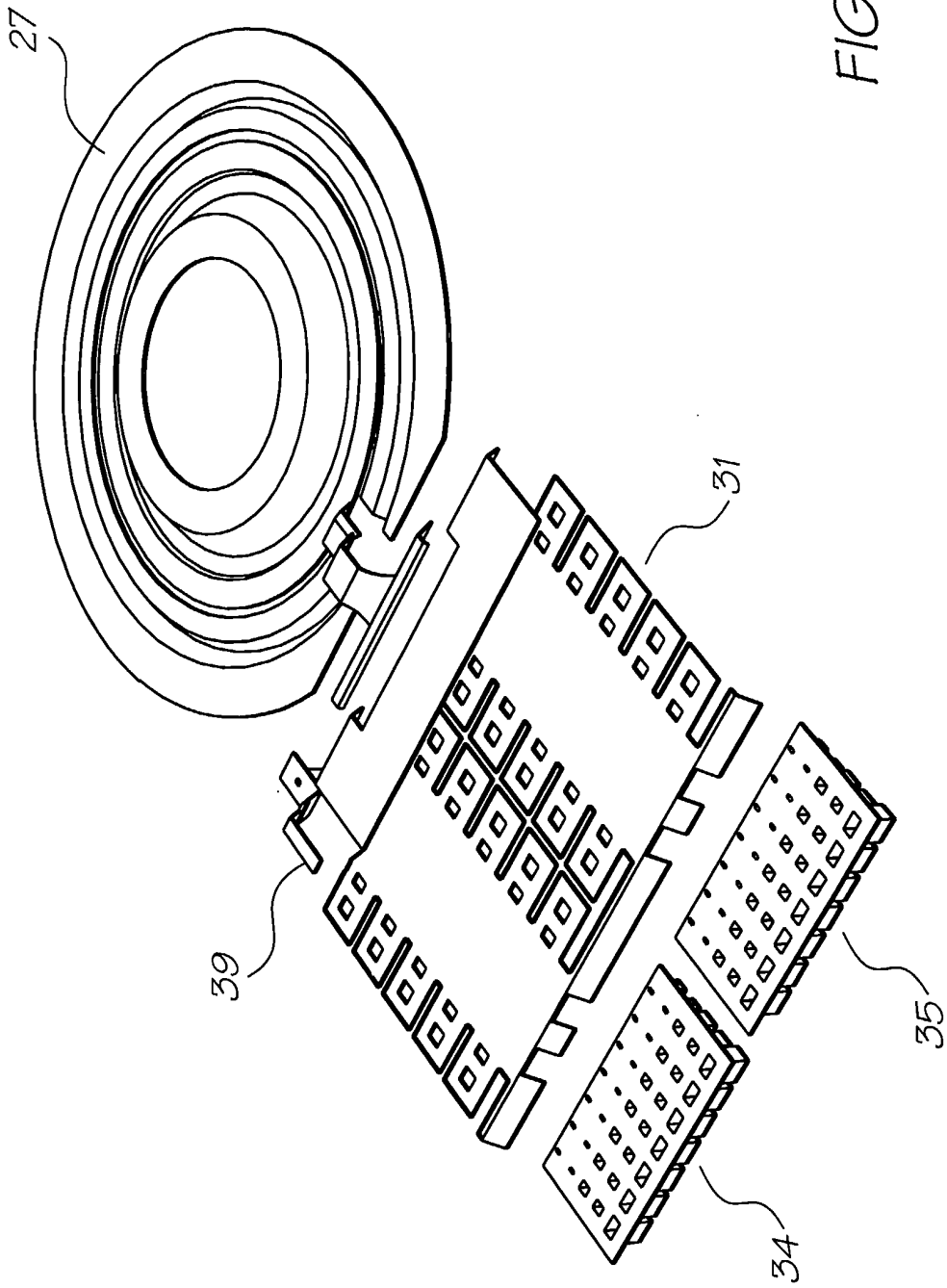

FIG. 3

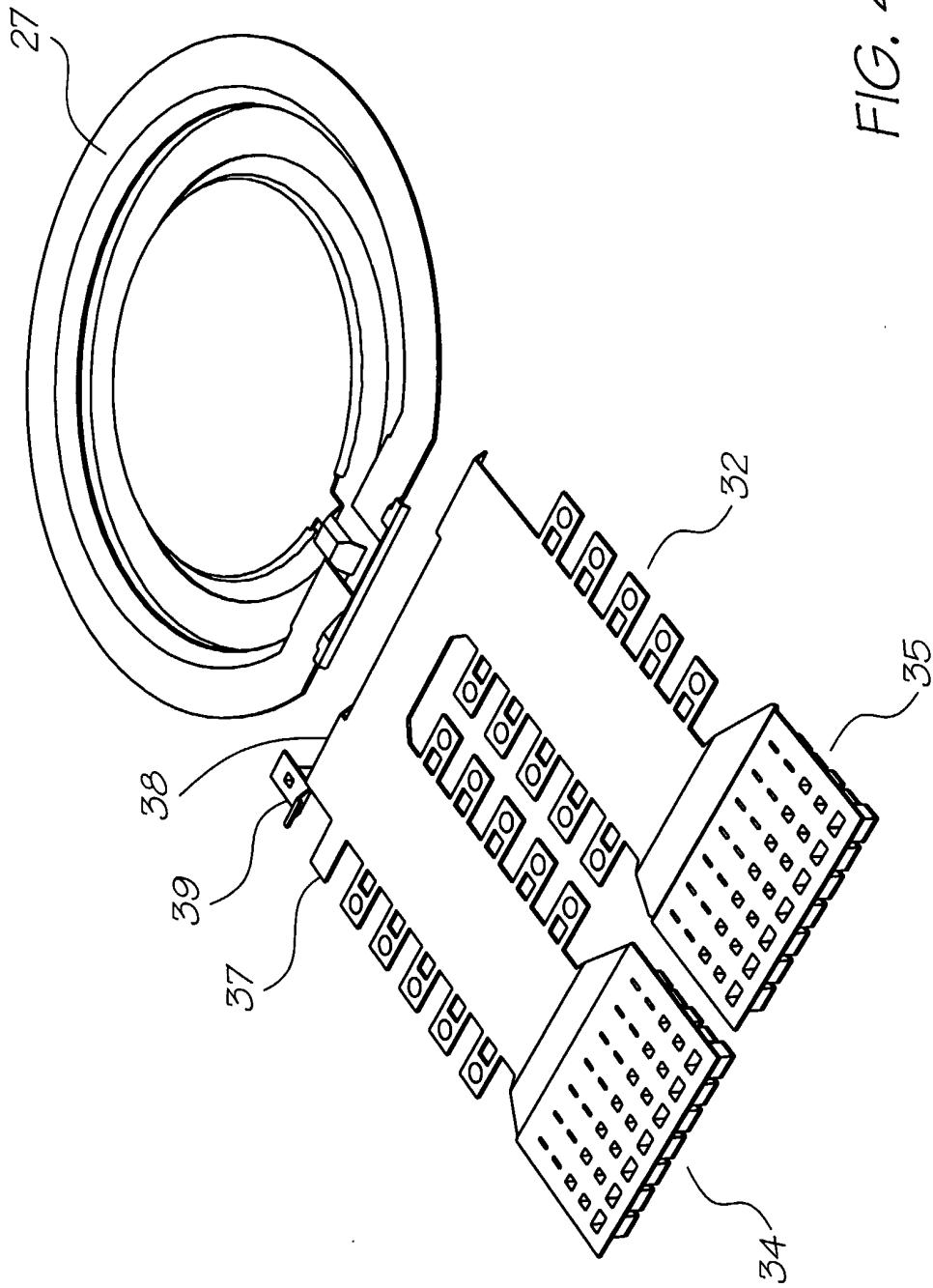

FIG. 4

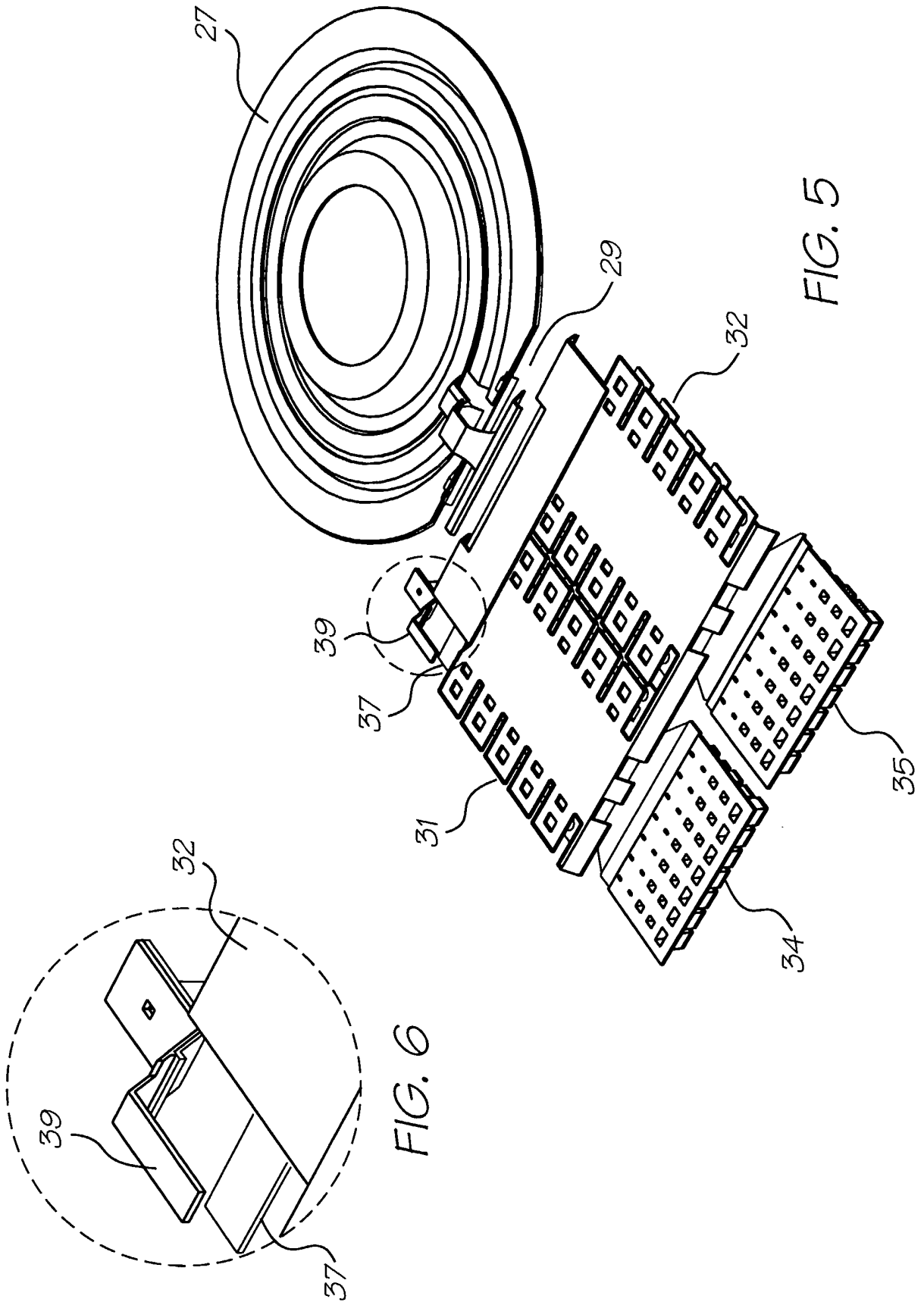

FIG. 5

FIG. 6

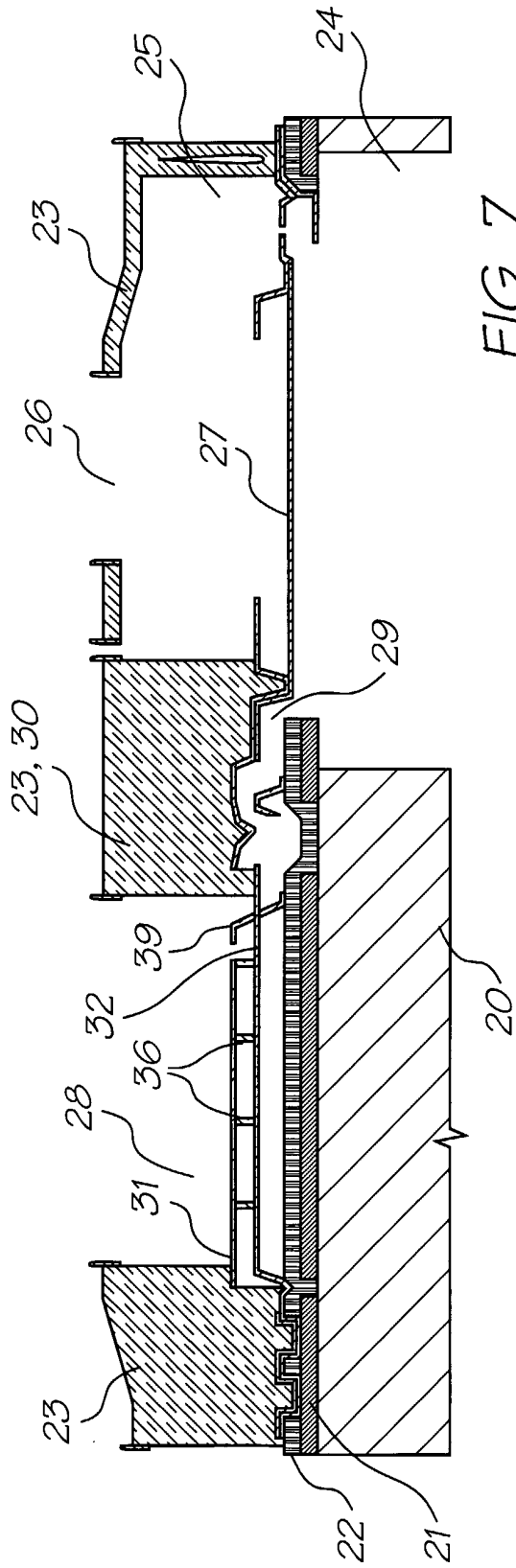

FIG. 7

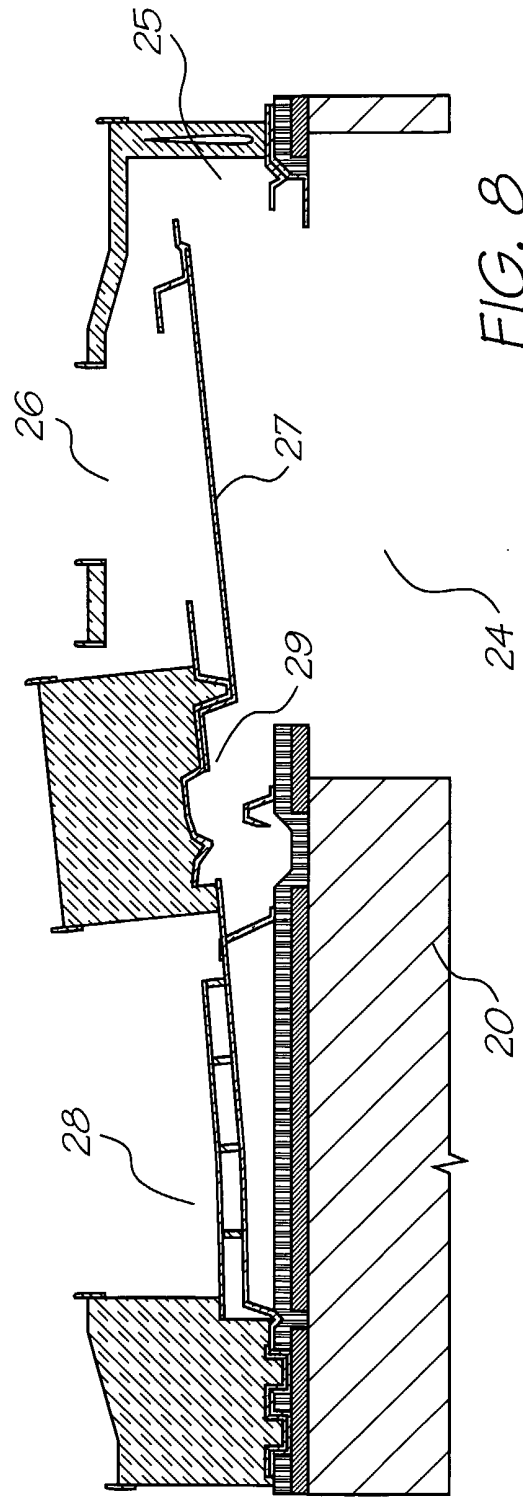

FIG. 8

7/11

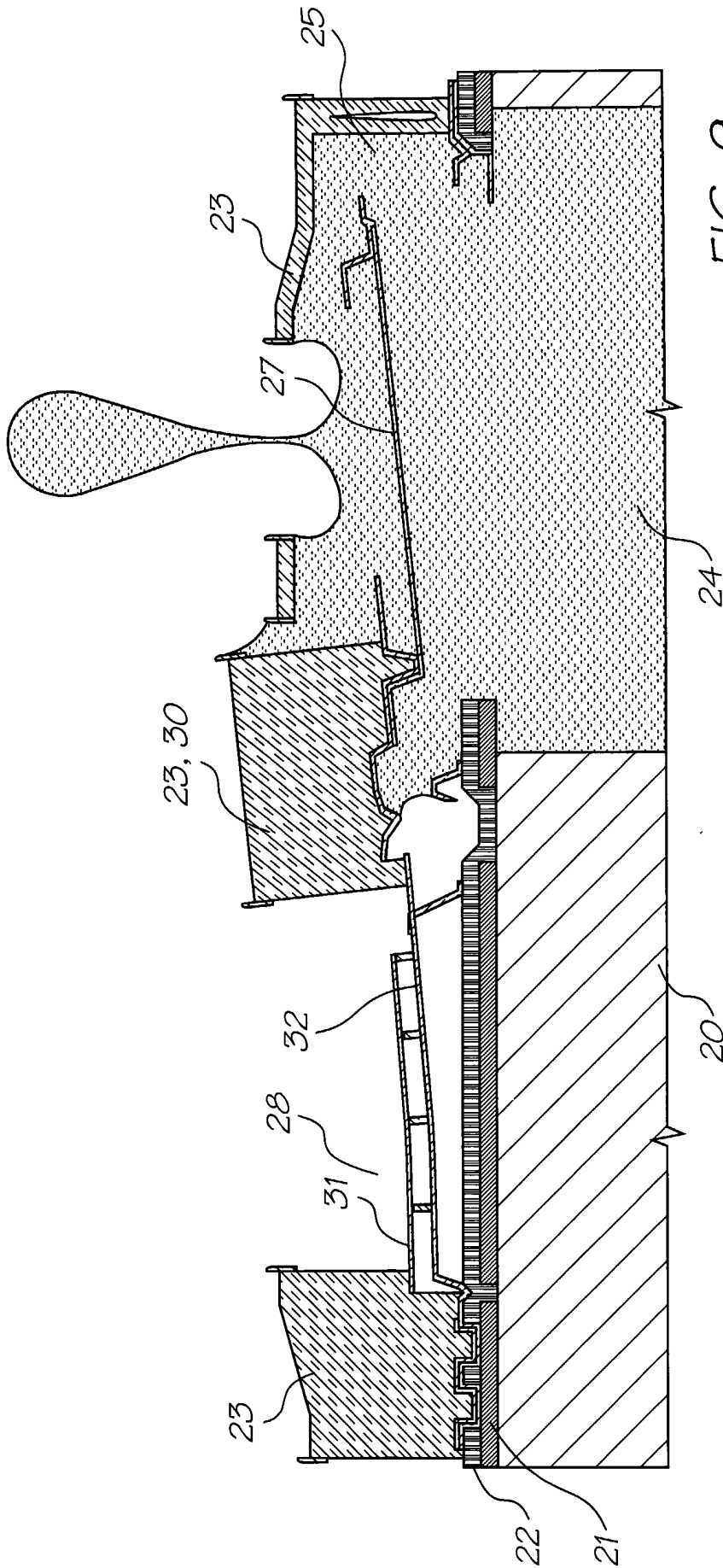

FIG. 9

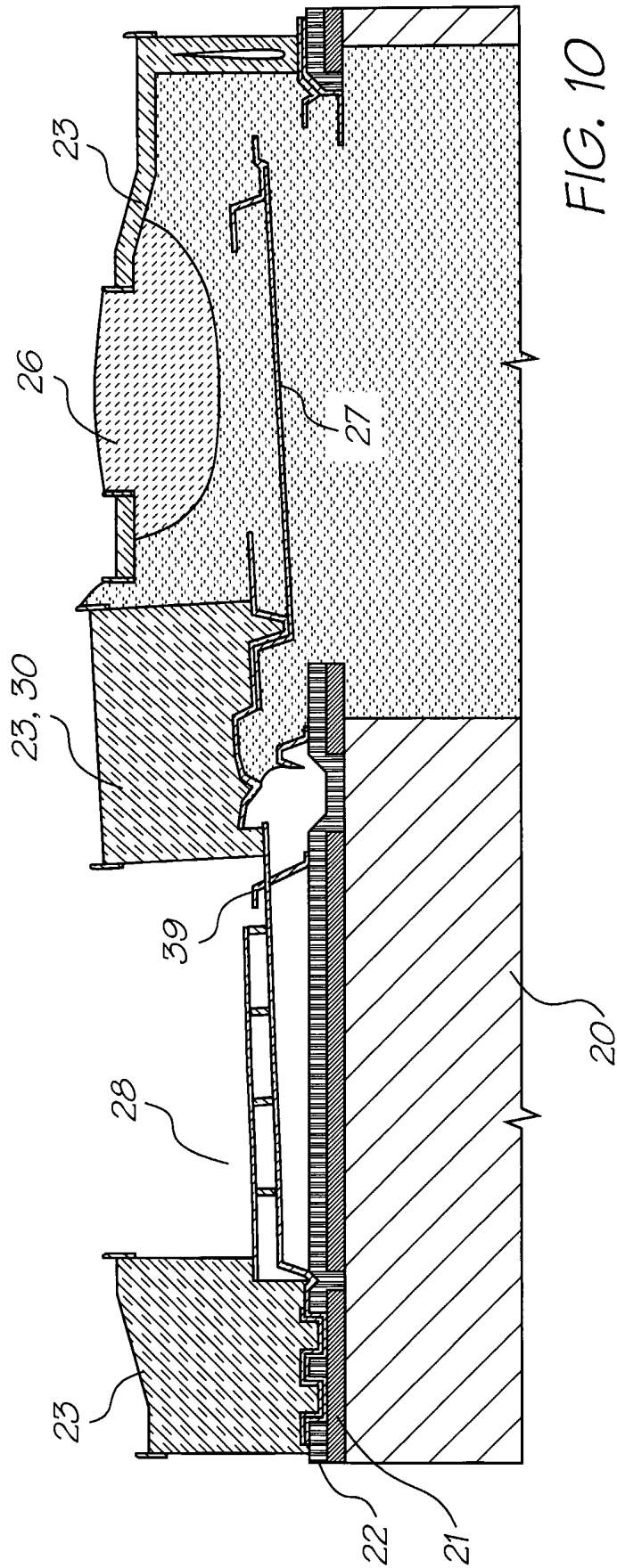

FIG. 10

9/11

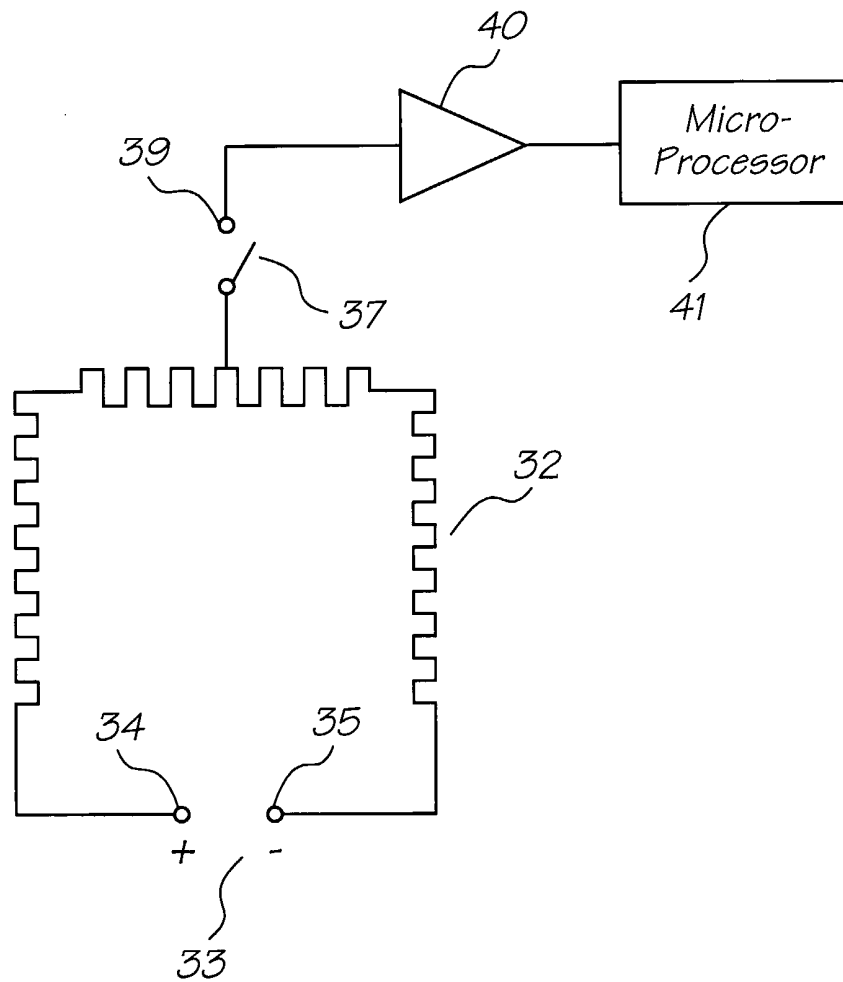

FIG. 11

10/11

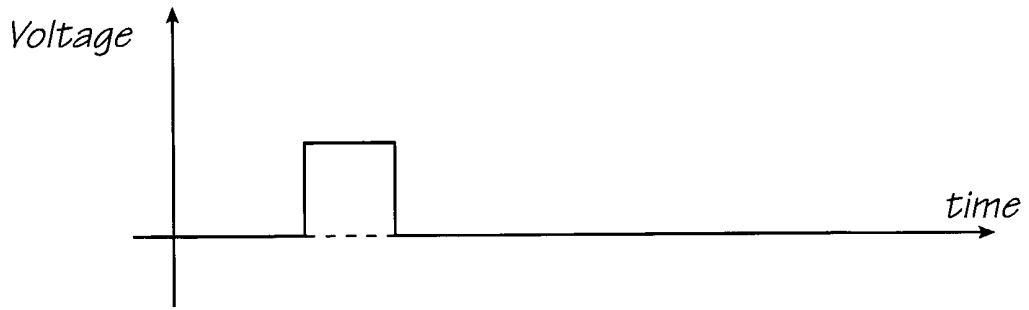

FIG. 12

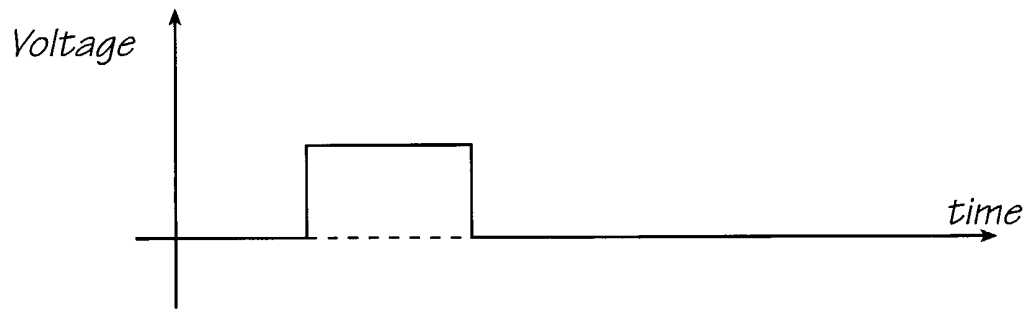

FIG. 13

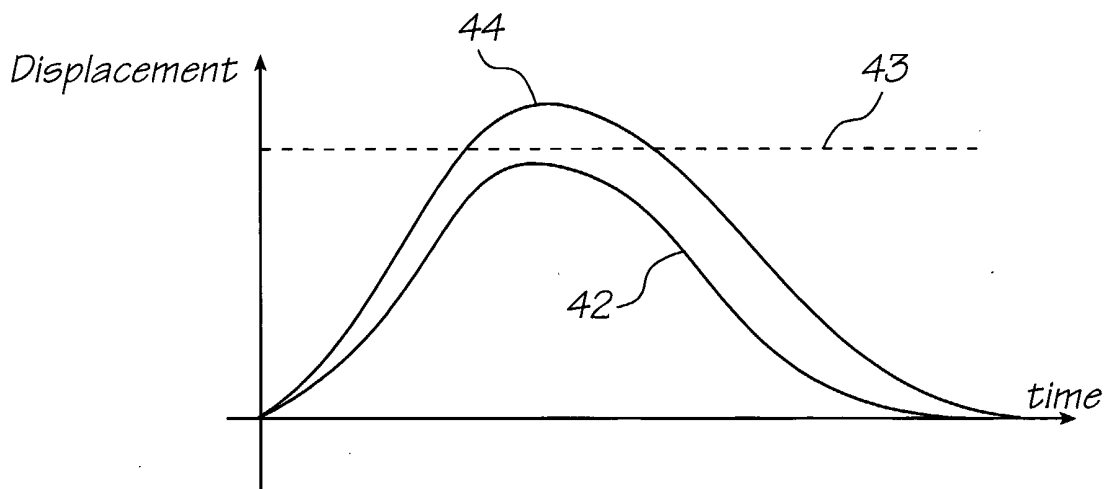

FIG. 14

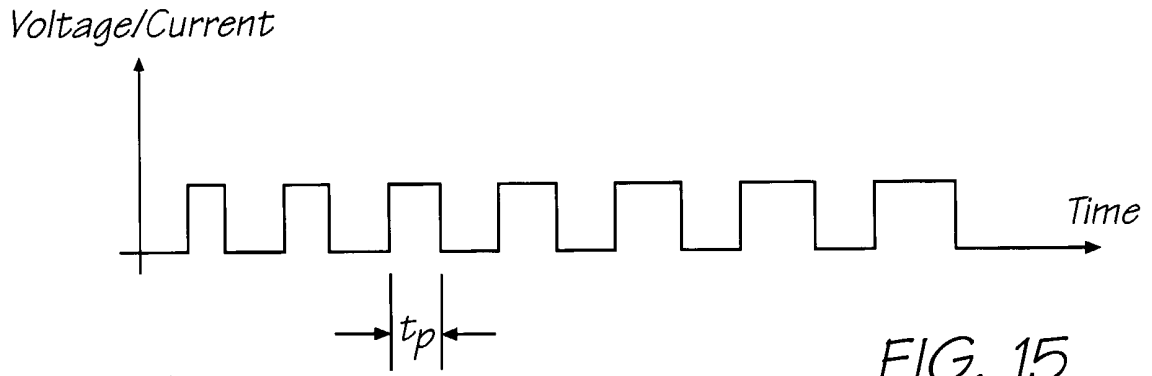

FIG. 15

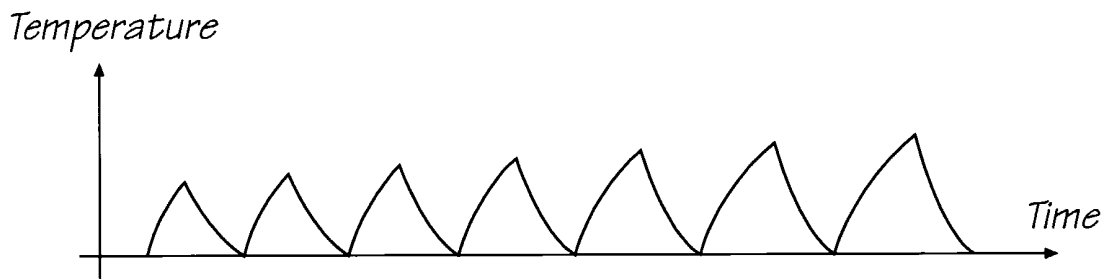

FIG. 16

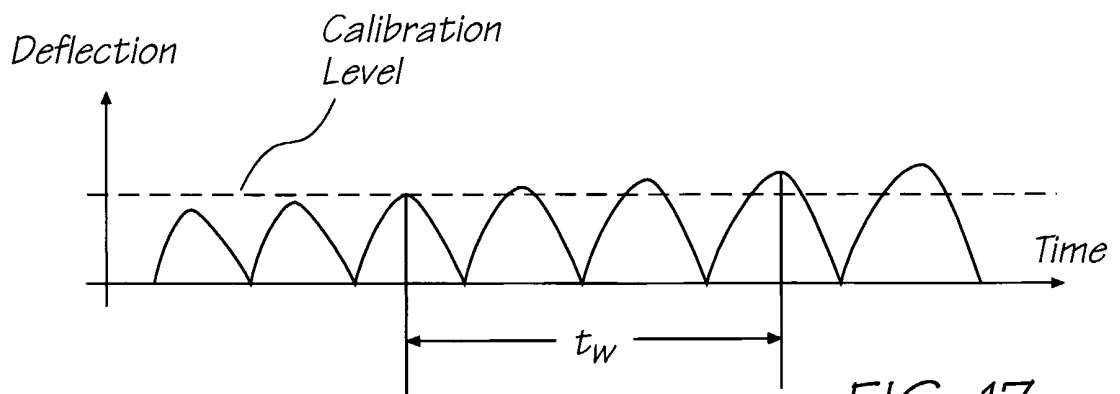

FIG. 17

INTERNATIONAL SEARCH REPORT

International application No.

PCT/AU00/00584

A. CLASSIFICATION OF SUBJECT MATTERInt. Cl. ⁷: B41J 2/045

According to International Patent Classification (IPC) or to both national classification and IPC

B. FIELDS SEARCHED

Minimum documentation searched (classification system followed by classification symbols)

IPC: B41 J 2/-

Documentation searched other than minimum documentation to the extent that such documents are included in the fields searched

Electronic data base consulted during the international search (name of data base and, where practicable, search terms used)

DWPI, JAPIO, USPTO

C. DOCUMENTS CONSIDERED TO BE RELEVANT

Category*	Citation of document, with indication, where appropriate, of the relevant passages	Relevant to claim No.
A	WO 99/03681 A (SILVERBROOK RESEARCH PTY LTD) 28 January 1998	
A	WO 99/03680 A (SILVERBROOK RESEARCH PTY LTD) 28 January 1998	

 Further documents are listed in the continuation of Box C See patent family annex

* Special categories of cited documents:

"A" document defining the general state of the art which is not considered to be of particular relevance

"E" earlier application or patent but published on or after the international filing date

"L" document which may throw doubts on priority claim(s) or which is cited to establish the publication date of another citation or other special reason (as specified)

"O" document referring to an oral disclosure, use, exhibition or other means

"P" document published prior to the international filing date but later than the priority date claimed

"T" later document published after the international filing date or priority date and not in conflict with the application but cited to understand the principle or theory underlying the invention

"X" document of particular relevance; the claimed invention cannot be considered novel or cannot be considered to involve an inventive step when the document is taken alone

"Y" document of particular relevance; the claimed invention cannot be considered to involve an inventive step when the document is combined with one or more other such documents, such combination being obvious to a person skilled in the art

"&" document member of the same patent family

Date of the actual completion of the international search

9 June 2000

Date of mailing of the international search report

1 August 2000

Name and mailing address of the ISA/AU

AUSTRALIAN PATENT OFFICE
 PO BOX 200, WODEN ACT 2606, AUSTRALIA
 E-mail address: pct@ipaustrialia.gov.au
 Facsimile No. (02) 6285 3929

Authorized officer

JAGDISH BOKIL

Telephone No : (02) 6283 2371

INTERNATIONAL SEARCH REPORT
Information on patent family members

International application No.
PCT/AU00/00584

This Annex lists the known "A" publication level patent family members relating to the patent documents cited in the above-mentioned international search report. The Australian Patent Office is in no way liable for these particulars which are merely given for the purpose of information.

Patent Document Cited in Search Report		Patent Family Member					
WO	9903681	WO	9904368	EP	999934	US	6041600
& WO	9903680	US	6044646	AU	83238/98	AU	83236/98
		EP	999933	WO	9904551	AU	83235/98
		AU	83227/98	EP	997033		
END OF ANNEX							