

(19) World Intellectual Property
Organization
International Bureau



(43) International Publication Date
15 January 2004 (15.01.2004)

PCT

(10) International Publication Number
WO 2004/006327 A2

- (51) International Patent Classification⁷: **H01L 21/762**
- (21) International Application Number: PCT/IB2003/003466
- (22) International Filing Date: 9 July 2003 (09.07.2003)
- (25) Filing Language: English
- (26) Publication Language: English
- (30) Priority Data:
02/08600 9 July 2002 (09.07.2002) FR
- (71) Applicant (for all designated States except US): **S.O.I. TEC SILICON ON INSULATOR TECHNOLOGIES** [FR/FR]; Parc Technologique des Fontaines, Chemin des Franques, F-38190 Bernin (FR).
- (72) Inventors; and
- (75) Inventors/Applicants (for US only): **GHYSELEN, Bruno** [FR/FR]; 58, rue Georges Maeder, F-38170 Seyssinet-Pariset (FR). **AULNETTE, Cécile** [FR/FR]; 3, Place des Tilleuls, F-38000 Grenoble (FR). **OSTERNAUD, Bénédite** [FR/FR]; 26, Rue Lieutenant Fiancey, F-38120 Saint Egreve (FR). **DAVAL, Nicolas** [FR/FR]; 15 Boulevard Maréchal Leclerc, F-38000 Grenoble (FR).
- (74) Agents: **MARTIN, Jean-Jacques** et al.; Cabinet Regimbeau, 20, rue de Chazelles, F-75847 Paris Cedex 17 (FR).
- (81) Designated States (national): AE, AG, AL, AM, AT, AU, AZ, BA, BB, BG, BR, BY, BZ, CA, CH, CN, CO, CR, CU, CZ, DE, DK, DM, DZ, EC, EE, ES, FI, GB, GD, GE, GH, GM, HR, HU, ID, IL, IN, IS, JP, KE, KG, KP, KR, KZ, LC, LK, LR, LS, LT, LU, LV, MA, MD, MG, MK, MN, MW, MX, MZ, NI, NO, NZ, OM, PG, PH, PL, PT, RO, RU, SC, SD, SE, SG, SK, SL, SY, TJ, TM, TN, TR, TT, TZ, UA, UG, US, UZ, VC, VN, YU, ZA, ZM, ZW.
- (84) Designated States (regional): ARIPO patent (GH, GM, KE, LS, MW, MZ, SD, SL, SZ, TZ, UG, ZM, ZW), Eurasian patent (AM, AZ, BY, KG, KZ, MD, RU, TJ, TM), European patent (AT, BE, BG, CH, CY, CZ, DE, DK, EE, ES, FI, FR, GB, GR, HU, IE, IT, LU, MC, NL, PT, RO, SE, SI, SK, TR), OAPI patent (BF, BJ, CF, CG, CI, CM, GA, GN, GQ, GW, ML, MR, NE, SN, TD, TG).
- Published:**
— without international search report and to be republished upon receipt of that report
- For two-letter codes and other abbreviations, refer to the "Guidance Notes on Codes and Abbreviations" appearing at the beginning of each regular issue of the PCT Gazette.

(54) Title: TRANSFER OF A THIN LAYER FROM A WAFER COMPRISING A BUFFER LAYER

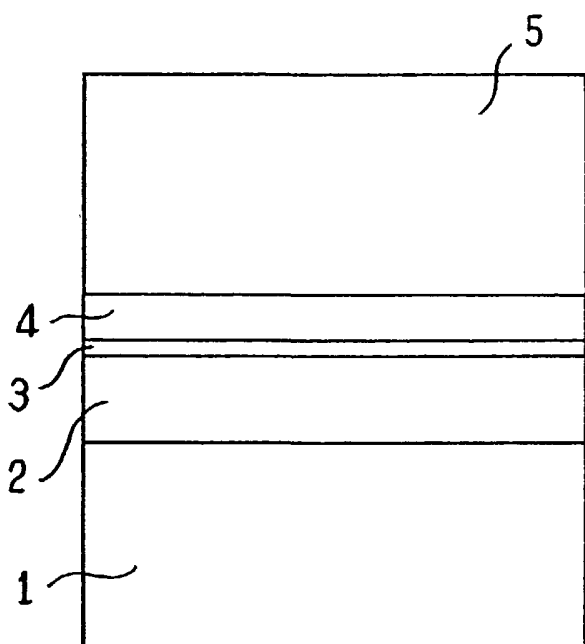

(57) Abstract: Method of producing a structure comprising a thin layer of semiconductor material obtained from a wafer (10), the wafer (10) comprising a lattice parameter matching layer (2) comprising an upper layer of semiconductor material having a first lattice parameter, a film (3) of semiconductor material having a nominal lattice parameter substantially different from the first lattice parameter, said grown film (3) being strained by the matching layer (2), a relaxed layer (4) a nominal lattice parameter to substantially identical to the first lattice parameter, the method comprising transfer of the relaxed layer (4) and the strained film (3) to a receiving substrate (5) and enrichment in an element other than silicon of the relaxed layer (4), thus increasing the relaxed layer (4) lattice parameter.

WO 2004/006327 A2

"TRANSFER OF A THIN LAYER FROM A WAFER COMPRISING
A BUFFER LAYER"

The present invention relates to a transfer of thin layers from a wafer to a receiving substrate, in order to form structures such as a semiconductor-on-insulator structures, also called a SeOI (Semiconductor-on-insulator) structures.

A first object of a such transfer is usually to produce electronic structures whose active layer, that is to say the layer which comprises or which will comprise the electronic components, is particularly thin and particularly homogeneous through the thickness.

A second object of the transfer can also be to produce these structures by transferring the active layer onto a receiving substrate from a wafer comprising a buffer layer.

A third object of the transfer may be to provide the possibility of reusing part of the wafer, and especially at least part of the buffer layer, for another transfer.

The term "buffer layer" is understood to mean a layer intermediate between two crystallographic structures with different lattice parameters, having in the region of one of its faces a lattice parameter substantially identical to that of the first structure and in the region of its other face a lattice parameter substantially identical to that of the second structure.

Thus, a wafer may, for example, comprise a single-crystal silicon (also called Si) wafer on which a relaxed layer of silicon-germanium (also called SiGe) is produced by means of a buffer layer, despite the difference in lattice parameter existing between these two materials.

By "relaxed layer" it is meant a layer of a semiconductor material, having a crystallographic relaxation rate, as measured by X-ray diffraction or Raman spectroscopy, superior to 50%. A layer having a 100% relaxation rate, has a lattice parameter substantially identical to the nominal lattice parameter of the material of the layer, that is to say the lattice parameter of the material in its bulk form in equilibrium.

Conversely, the term "strained layer" means any layer of a semiconductor material whose crystallographic structure is strained in tension or in compression during crystal growth, such as epitaxy, requiring at least one lattice parameter to be substantially different from the nominal lattice parameter of this material.

Thus, a buffer layer makes it possible to grow a SiGe layer on a Si substrate without this SiGe layer being strained by the Si substrate.

Given that bulk SiGe is usually not available on the market, the use of a buffer layer in a wafer in order to have a relaxed SiGe layer on the surface makes it possible to produce a structure which can thus fulfil the same functions as a bulk SiGe substrate.

5 The buffer layer inserted between the Si wafer and the relaxed SiGe layer is generally made of SiGe, with a quantitywise proportion of germanium which progressively increases through the thickness of the wafer towards the relaxed layer.

10 Thus a silicon-germanium buffer layer can be referred as a $\text{Si}_{1-x}\text{Ge}_x$ buffer layer, the x parameter representing the germanium concentration in the buffer layer increasing progressively from 0 to r .

The relaxed SiGe layer on the surface of the $\text{Si}_{1-x}\text{Ge}_x$ buffer layer is thus referred as the relaxed $\text{Si}_{1-r}\text{Ge}_r$ layer, the r parameter representing the germanium concentration in said relaxed layer.

15 Thus, the $\text{Si}_{1-x}\text{Ge}_x$ buffer layer makes it possible to:

- gradually increase the germanium content x from the wafer ($x=0$) towards the relaxed layer ($x=r$);

- confine defects associated with the difference in lattice parameter so that they are buried;

20 - give a sufficiently thick relaxed $\text{Si}_{1-r}\text{Ge}_r$ layer stability with respect to a film of different material epitaxially grown on its surface in order to strain the latter so as to modify its lattice parameter without influencing that of the relaxed $\text{Si}_{1-r}\text{Ge}_r$ layer.

25 For all these reasons, the buffer layer must be sufficiently thick, typically having a value greater than one micron.

It has also to be stated that controlling the germanium concentration within a relaxed SiGe layer makes it possible to control its lattice parameter and thus the strain exerted on a film epitaxially grown on said relaxed SiGe layer.

30 Another object of the invention aims at controlling the different structural states (strain or relaxation rates) of the various layers composing the final structure (such as a relaxed SiGe layer) and more particularly at exceeding the restrictions of the current techniques limiting to approximately 30% the concentration r of germanium within the relaxed $\text{Si}_{1-r}\text{Ge}_r$ layer on the surface of the $\text{Si}_{1-x}\text{Ge}_x$ buffer layer.

35 Processes of transferring the layer of relaxed material grown epitaxially on such a buffer layer from the wafer on to a receiving substrate are known.

Such processes are, for example, proposed in an IBM document by

L.J. Huang et al. ("*SiGe-On-Insulator prepared by wafer bonding and layer transfer for high-performance field-effect transistors*", Applied Physics Letters, 26/02/2001, Vol. 78, No. 9) and in document WO 02/33746, in which documents an SGOI (Silicon-Germanium-On-Insulator) structure is produced from a wafer comprising in succession a single-crystal Si support substrate, an SiGe buffer layer and a relaxed SiGe layer.

One process employed in a document by L.J. Huang et al. consists in carrying out a Smart-Cut® process of the Applicant, known to those skilled in the art, and descriptions of which may be found in a number of works dealing with wafer reduction techniques, in order to remove the relaxed SiGe layer so as to transfer it by means of bonding on to an oxidized receiving substrate, thus producing an SGOI structure.

Despite the advantages that this process affords, a few rough areas may form on the surface of the transferred layer and a surface finishing step then has to be carried out.

This finishing step is generally carried out by means of CMP (chemical-mechanical polishing or chemical-mechanical planarization), which may create surface defects (such as strain-hardened regions), which may imperfectly correct the thickness, and thus retain inhomogeneous layer thicknesses, and which may slow down the transfer of the SiGe layer, and increase its cost.

The process presented in document WO 02/33746 includes, in addition to a CMP polishing step, preliminary lapping, polishing and etching steps in order to remove part of the wafer, thereby slowing down the overall process of removal from the wafer and increasing its cost even further, while not ensuring good homogeneity in layer thickness.

The abovementioned first object of the transfer is therefore not sufficiently achieved in this case.

To try to alleviate this, document US 5 882 987 and US 6 323 108 disclose an overall process for producing SOI (silicon-on-insulator) structures from a wafer comprising in succession a single-crystal Si support substrate, an SiGe layer and an epitaxially grown Si layer bonded to an oxidized receiving substrate.

The Smart-Cut® technique is employed and causes, after bonding the wafer to a receiving substrate, detachment of part of the wafer at the Si support substrate.

A structure consisting in succession of part of the Si support substrate, the SiGe layer and the epitaxially grown Si layer is thus removed, the whole assembly being bonded to the oxidized receiving

substrate.

Two successive selective etching operations are then carried out on the structure in order to remove firstly the remaining part of the Si support substrate with an etching solution such that the SiGe layer forms a stop layer and then in order to remove the SiGe layer with an etching solution such that the Si layer forms a stop layer.

The structure obtained at the end is an SOI structure with a surface Si layer.

Thus, an SeOI structure is obtained with a semiconductor layer which is both thin and uniform through the thickness, substantially identical to the epitaxially grown initial layer, while avoiding the use of a finishing step other than a selective etching operation.

However, the SiGe layer inserted between the Si wafer and the epitaxially grown Si layer has a typical thickness of between 0.01 and 0.2 microns, a thickness which is insufficient, as mentioned above, to pretend to fulfil the role of a buffer layer between the Si wafer and a potential relaxed SiGe layer.

The wafer therefore does not include a buffer layer.

The abovementioned second object of the transfer is therefore not achieved in this case.

In addition, given the order of magnitude of the thickness of the inserted SiGe layer, the structural state of the latter does not seem defined with certainty.

Now, another main objective of the transfer relates also to the production of a final structure comprising one or more layers in substantially controlled structural states, such as a substantially relaxed SiGe layer, something which does not seem to be guaranteed in the production of a structure described in the document US 6 323 108.

As regards document WO 01/99169, this provides processes for producing, from a wafer consisting in succession of an Si substrate, an SiGe buffer layer, a relaxed SiGe layer and optionally a strained Si or SiGe layer, a final structure with the relaxed SiGe layer on the optional other strained Si or SiGe layer.

The technique employed for producing such a structure involves, after bonding the wafer to a receiving substrate, removal of the material of the wafer that it is desired not to retain, by selectively etching the Si substrate and the SiGe buffer layer.

Although it transpires that this technique does make it possible to achieve particularly small layer thicknesses which are homogeneous

through the thickness, it entails, however, destruction of the Si substrate and the SiGe buffer layer by chemical etching.

These processes therefore do not allow the possibility of reusing part of the wafer, and especially at least part of the buffer layer, for a further transfer of layers.

The third object of the transfer mentioned at the start of the document is therefore not achieved in this case.

WO 02/15244 document describes a source wafer, provided before transfer, comprising relaxed SiGe layer/strained Si/SiGe layer / buffer SiGe layer / Si substrate structure.

Then, the transfer consists doing a Smart-Cut® process at the strained Si layer level.

Implanting ions in the strained layer of Si can be difficult to operate due to the thickness of a such layer, and can thus lead to creation of structural damages inside the SiGe layers surrounding it.

In order in particular to achieve these objectives, the present invention provides, according to a first aspect, a method of producing a structure comprising a thin layer of semiconductor material obtained from a wafer, the wafer comprising a lattice parameter matching layer comprising an upper layer of a material chosen from semiconductor materials having a first lattice parameter, characterized in that it comprises the following steps:

(a) growth on the upper layer of the matching layer of a film of a material chosen from semiconductor materials, said grown film being of a material having a nominal lattice parameter substantially different from the first lattice parameter, said grown film having a thickness small enough to keep the first lattice parameter of the upper layer of the underlyed matching layer and thus to be strained;

(b) growth on the film of a relaxed layer, said relaxed layer being of a material chosen from semiconductor materials comprising silicon and at least another element and having a nominal lattice parameter substantially identical to the first lattice parameter;

(c) removal of at part of the wafer, comprising the following operations:

- formation of an embrittlement zone in the matching layer; and
- supply of energy in order to detach, at the embrittlement zone level, the part of the wafer comprising the relaxed layer, thus forming the structure to produce;

(d) enrichment in an element other than silicon of the relaxed layer comprised in the detached part of the wafer.

Further characteristics of the method according to the invention are the following :

- the enrichment step comprises an oxidation operation of the detached part of the wafer for forming an oxide layer on the surface of the thus oxidized detached part of the wafer and increasing the concentration of the element other than silicon in a region of said relaxed layer which is subjacent said oxide layer;
- the enrichment step may also comprises a deoxidation operation for removing the oxide layer formed during said oxidation operation.
- the enrichment step may also comprises a heat treatment operation for homogenising the concentration of the element other than silicon within said oxidized part of the wafer;
- the heat treatment operation can be carried out after the oxidation operation, either before or after said deoxydation operation;
- the heat treatment operation is preferentially carried out at a temperature of approximately 1200°C;
- after the growth step (b), an additional step is carried out in which a receiving substrate is bonded to the wafer on the relaxed layer side;
- in this case, the receiving substrate is made of silicon;
- in either of these latter two cases, before bonding, a step of forming at least one bonding layer between the receiving substrate and the wafer is furthermore carried out, the bonding layer being formed on the receiving substrate and/or on the bonding face of the wafer;
- in the latter case, the bonding layer is an electrically insulating material such as silica;
- the embrittlement zone is formed by implantation of species into the matching layer at a depth substantially equal to the implant depth;
- before the growth step (b), the embrittlement zone is formed by porosification of a layer beneath the relaxed layer;
- the removal step (c) comprises, after the energy supply operation of said removal step (c), at least one selective etching operation;
- in one of the latter two cases, a selective etching operation relates to the etching of the remaining part of the matching layer with respect to the film (after detachment of the wafer by energy supply) ;

- it further comprises after said etching operation and before the enrichment step (d) a growth on the film (3) of a film of a semiconductor material substantially the same as the one of the film (3) ;
- it further comprises an oxidation of said grown film ;
- 5 – an annealing treatment is operated at the same time or following the oxidation, this annealing treatment being able to strengthen the bonding interface.
 - in the latter case, a selective etching operation relates to the etching of the film with respect to the relaxed layer;
- 10 – the process furthermore comprises, after the removal step (c), a step of growing a layer on the relaxed layer;
 - in this case, the growth layer on the relaxed layer is made of strained material;
 - the matching layer is made of silicon-germanium (the matching layer comprising a buffer layer with a germanium concentration which increases through the thickness and a relaxed layer beneath the film), the film of strained material is made of silicon, the element other than silicon is germanium so that the relaxed layer is made of substantially relaxed silicon-germanium (with a germanium concentration substantially equal to
 - 20 the germanium concentration of the relaxed layer of the matching layer);
 - the element other than silicon in the relaxed layer may also be carbon or an alloy germanium-carbon;
 - in the latter cases, the growth layer produced on the relaxed layer is made of strained silicon so as to substantially preserve the lattice
 - 25 parameter of the subjacent relaxed silicon-germanium layer;
 - the wafer comprises at least one layer furthermore containing carbon with a carbon concentration in the layer substantially less than or equal to 50% ;
 - the wafer comprises at least one layer furthermore containing carbon
 - 30 with a carbon concentration in the layer substantially less than or equal to 5%.

According to a second aspect, the invention provides a structure, obtained as indicated by the method proposed by the first aspect of the invention after a bounding step with a receiving substrate and said

enrichment step (d), comprising in succession at least a receiving substrate and the relaxed layer comprised in the detached part of the wafer and enriched in its element other than silicon, characterized in that said relaxed layer has a lattice parameter substantially superior to said first
5 lattice parameter;

According to a third aspect, the invention provides an application of the method proposed by the first aspect of the invention to the production of one of the following "semiconductor on insulator" structures : SGOI, strained Si / SGOI, SiGe / strained Si / SGOI, SiO₂ / SGOI.

10 Further aspects, objects and advantages of the present invention will become more clearly apparent on reading the following detailed description of the implementation of preferred processes of the invention, these being given by way of non-limiting example and with reference to the appended drawings in which:

- 15 - figures 1a, 1b, 1c, 1d, 1e and 1f show the various steps of a method of producing an electronic structure comprising a thin SiGe layer according to the invention;
- figures 2a, 2b, 2c and 2d show the various steps of a treatment applied to a layer made of a semiconductor material comprising
20 silicon and at least another element in order to enrich said layer in said other element.

An example of a method according to the invention will now be described below, which starts, with reference to figure 1a, from a wafer
25 consisting in the first place of a single-crystal silicon support substrate 1 and a lattice parameter matching layer 2 made of a semiconductor material comprising silicon and at least another element.

The expression "lattice parameter matching layer" denotes any structure behaving as a buffer layer and having, on the surface, a layer of substantially relaxed material without an appreciable number of structural
30 defects, such as dislocations.

Thus, in our example, it will be advantageous to choose a lattice parameter matching layer 2 made of a semiconductor material comprising silicon and germanium.

Said SiGe lattice parameter matching layer 2 consists in succession
35 of a Si_{1-x}Ge_x buffer layer, the concentration x of germanium within this buffer layer increasing progressively from 0 to r, and a relaxed Si_{1-r}Ge_r layer on the surface of said Si_{1-x}Ge_x buffer layer.

The buffer layer preferably has a germanium concentration x which

grows uniformly from the interface with the support substrate 1, for reasons which were explained above. Its thickness is typically between 1 and 3 micrometers in order to obtain good structural relaxation on the surface.

5 The relaxed $\text{Si}_{1-r}\text{Ge}_r$ layer has advantageously been formed by epitaxy on the surface of the buffer layer and its thickness may vary widely depending on the case, with a typical thickness of between 0.5 and 1 micron.

10 The germanium present in the silicon at a concentration r within the relaxed $\text{Si}_{1-r}\text{Ge}_r$ layer makes it possible to strain a Si film 3, grown on said relaxed $\text{Si}_{1-r}\text{Ge}_r$ layer during the next step (shown by Figure 1b).

However, the cost of a buffer layer is generally very important, and its quality is badly controlled once the maximum concentration of germanium within a $\text{Si}_{1-x}\text{Ge}_x$ buffer layer becomes high.

15 Indeed current techniques limit to approximately 30% the concentration r of germanium within the relaxed $\text{Si}_{1-r}\text{Ge}_r$ layer on the surface of the SiGe lattice parameter matching layer 2. Hence, the constraint exerted on the Si film 3 grown on said matching layer 2 is also limited.

20 With reference to Figure 1b, an Si film 3 is grown on the SiGe matching layer 2.

In a first case, the film 3 is grown *in situ*, directly in continuation with the formation of the subjacent matching layer 2, the latter also being in this case advantageously formed by layer growth.

25 In the second case, the film 3 is grown after a gentle finishing step carried out on the surface of the subjacent matching layer 2, for example by CMP polishing.

30 The Si film 3 is advantageously formed by epitaxy using techniques such as CVD (chemical vapour deposition) and MBE (molecular beam epitaxy) techniques.

The silicon of the film 3 is then obliged by the matching layer 2 to increase its nominal lattice parameter in order to make it substantially identical to that of its growth substrate and thus introduce internal tensile strains.

35 It is necessary to form quite a thin Si film 3 - this is because too great a film thickness would cause the strain in the thickness of the film to relax towards the nominal lattice parameter of the silicon and/or defects to be generated in the film 3.

The thickness of the film 3 is thus typically less than 200 angstroms in

order to avoid any relaxation of the strain therein.

Referring to Figure 1c, a relaxed SiGe layer 4 is grown on the strained Si film 3, advantageously by epitaxy (for example by CVD or MBE).

5 This relaxed SiGe layer is produced either *in situ*, immediately after growth of the subjacent film 3, or after a soft finishing step carried out on the surface of the subjacent film 3, such as a CMP polishing step.

The germanium concentration in this layer 4 is substantially the same as that present near the bonding face of the matching layer 2 (that is to say a concentration r in Ge), so as to keep the nominal matching parameter of the relaxed $\text{Si}_{1-r}\text{Ge}_r$ layer present at this level in the matching layer 2 and preserved in the strained Si film 3.

10 The thickness of this relaxed SiGe layer 4 may be from a few tens to a few hundreds of nanometres, preferably between 10 and 100 nanometres.

15 With reference to Figure 1d, a receiving substrate 5 is advantageously bonded to the relaxed SiGe layer 4.

This receiving substrate 5 may, for example, be made of silicon or may consist of other types of materials.

20 The receiving substrate 5 is bonded by bringing it into intimate contact with the relaxed layer 4, advantageously effecting molecular adhesion (wafer bonding) between the substrate 5 and the layer 4.

This bonding technique, as well as variants, is especially described in the document entitled "*Semiconductor Wafer Bonding*" (Science and Technology, Interscience Technology) by Q.Y. Tong, U. Gösele and Wiley.

25 If necessary, bonding is accompanied by an appropriate prior treatment of the respective surfaces to be bonded and/or by supplying thermal energy and/or supplying an additional bonding layer.

30 Thus, for example, a heat treatment carried out during bonding allows the bonds to be strengthened.

Bonding may also be reinforced by a bonding layer inserted between the layer 4 and the receiving substrate 5, which makes it possible to produce molecular bonds both with the layer 4 and with the material constituting the bonding face of the receiving substrate 5 which are at least as strong as those existing between the layer 4 and the receiving substrate 5.

35 Thus, silicon oxide (also called silica or SiO_2) is a material that may be chosen for producing such a bonding layer. The silica may be formed on the relaxed layer 4 and/or on the receiving substrate 5, by SiO_2 deposition

or by thermal oxidation on the respective bonding surfaces.

Advantageously, the material constituting the bonding face of the receiving substrate 5 and/or the material of the bonding layer optionally formed is electrically insulating, in order in the end to produce an SeOI structure 20, the semiconductor layer of the SeOI structure then being the transferred relaxed layer 4.

Once the receiving substrate 5 has been bonded, part of the wafer 10 is removed in order to transfer the relaxed SiGe layer 4 on the receiving substrate 5 and thus produce the desired structure 20.

Substantially all that part of the wafer 10 on the matching layer 2 side in relation to the relaxed SiGe layer 4 is removed.

With reference to Figures 1e and 1f, this material removal is carried out in two steps.

A first step of material removal, shown in Figure 1e, consists in removing substantially the entire part of the wafer 10 on the matching layer 2 side in relation to the film 3.

To do this, a first material removal operation consists in detachment the donor wafer in a region of the matching layer 2 that has been weakened beforehand in this region.

Two known non-limiting techniques may thus carry out such an operation.

A first technique, called the Smart-Cut® technique, known to those skilled in the art (and descriptions of which may be found in a number of works dealing with wafer reduction techniques), consists in implanting atom species (such as hydrogen ions) and then in subjecting the implanted region, which then forms an embrittlement zone, to a heat treatment and/or mechanical treatment, or another supply of energy, in order to make the detachment in the embrittlement zone.

Detachment of the embrittlement zone thus formed in the matching layer 2 makes it possible to remove most of the wafer 10, in order to obtain a structure comprising the remainder of the matching layer 2, the strained Si film 3, the relaxed SiGe layer 4, the optional bonding layer and the receiving substrate 5.

A second technique consists in obtaining a weak interface by creating at least one porous layer, as described for example in document EP-A-0 849 788, and then in subjecting the weak layer to a mechanical treatment, or another supply of energy, in order to make the detachment in the weakened layer.

This weakened layer made of porous silicon is formed within the

support substrate 1, between the support substrate 1 and the matching layer 2, in the matching layer 2 (for example between a buffer layer and a relaxed layer) or on the matching layer 2 (that is to say between the matching layer 2 and the strained Si film 3).

5 To form a weakened layer within the support substrate 1, the porous layer is advantageously formed on a single-crystal Si wafer and then a second growth is carried out on the porous layer, so as to grow a non-porous Si layer having substantially the same lattice parameter as the Si of the wafer; the support substrate 1 then consists of the wafer, the porous
10 layer and the non-porous Si layer.

A detachment at the weakened layer makes it possible to remove at least some of the wafer 10, in order to obtain a structure comprising the optional remainder of the wafer 10, the strained Si film 3, the relaxed SiGe layer 4, optionally the inserted bonding layer and the receiving substrate 5.

15 A treatment of the wafer 10, in order to remove the porous silicon which remains after the detachment, is advantageously carried out, such as an etching operation or a heat treatment.

If the porous layer lies within the support substrate 1, a lapping, chemical-mechanical polishing and/or selective chemical etching
20 operations are then advantageously carried out in order to remove the remaining part of the support substrate 1.

These two non-limiting techniques make it possible to rapidly remove, en bloc, a substantial part of the wafer 10.

They also allow the possibility of reusing the removed part of the
25 wafer 10 in another process, such as for example a process according to the invention.

Thus, if the part removed is the support substrate 1, an operation to reform a matching layer 2, a film 3 and a relaxed layer 4 may be carried out as described above, after the surface of the support substrate 1 has been
30 polished.

A second material removal operation after detaching the wafer 10 according, for example, to one of the above two techniques, consists in removing, if necessary, the remaining part of the matching layer 2.

This operation may be carried out by selective chemical etching so
35 that the strained Si film 3 undergoes little or no etching, thus forming an etching stop layer.

The remaining part of the matching layer 2 is in this case etched by wet etching using etch solutions having substantial selectivities with respect to the strained Si film 3, such as a solution comprising

HF/H₂O₂/CH₃COOH (approximately 1/1000 selectivity) or HNA (hydrofluoric-nitric-acetic solution).

Dry etching operations may also be carried out in order to remove material, such as plasma etching, or by sputtering.

5 This chemical method has the main advantage of being quite rapid for thin layers to be removed and of avoiding the use of chemical-mechanical polishing finishing operations usually employed after detaching the wafer.

10 However, the chemical etching operation may advantageously be preceded, especially in the case of a thicker layer to be removed, by mechanical or chemical-mechanical abrasion by lapping and/or chemical-mechanical polishing CMP of the remaining part of the matching layer 2.

15 These techniques are proposed by way of an example in the present document, but they do not in any way constitute a limitation, the invention covering all types of techniques suitable for removing material from a wafer 10 in accordance with the process according to the invention.

A first application of the invention implies a preservation of the film 3, at least partially, in order to produce a strained Si/SGOI structure.

Optionally, a growth of Si is operating on the film 3 to thicken it.

20 The obtained strained layer after growth should stay below the critical thickness.

As the last step of etching the remaining part of the matching layer 2 may have damaged or thinned the film 3, an advantage of thickening the film 3, is to get back the initial thickness, or a more important thickness (still below the critical thickness).

25 This thick strained Si layer can then be used as an active layer (taking thus advantage of electrons high mobility that a such material exhibits).

Optionally, the strained Si of the film 3, thickened or not during the previous option, is at least oxidized.

30 A first interest of this oxidation step is to encapsulate the underlayer of SiGe, avoiding a Ge diffusion from it.

A second interest is found if an additional annealing step is implemented in order to strengthen the bond at the bonding interface.

Other advantages may be found, as for instance, an improvement of the film 3 quality.

35 Indeed said bonding annealing step is generally carried out within a range of temperature that can create some defaults in the structure, as for instance pinholes. As describe in WO99/52 145, presence of a SiO₂ layer on a semiconductor layer avoids most of problems during annealing.

Using the Si of film 3 as the material to oxidize is all the more

judicious than Si is industrially easier to oxidize than SiGe material.

In a particular embodiment of the invention, an enrichment step for enriching in germanium the relaxed SiGe layer 4 underneath the Si film 3 on top of the structure is carried out.

5 As it has already been stated before, the concentration of germanium within said relaxed SiGe layer 4 is substantially the same as that present in the relaxed $\text{Si}_{1-r}\text{Ge}_r$ layer on the surface of the SiGe lattice parameter matching layer 2.

10 r being limited to 30% due in particular to the limitations of the SiGe buffer layer production current techniques, the concentration of germanium within the relaxed SiGe layer 4 is thus limited.

Germanium presents an affinity with oxygen weaker than that of silicon with oxygen. Consequently, when a SiGe layer is exposed to an oxidizing atmosphere, silicon within the SiGe layer oxidizes preferentially while germanium within said SiGe layer does not react directly with oxygen.

15 Hence, the oxidation of a SiGe layer carried out by most of the known oxidation methods leads silicon to oxidize (forming in particular an silicon oxide layer, also called silica or SiO_2), and the germanium atoms, released by the oxidation of silicon, to migrate and accumulate at the SiO_2/SiGe interface.

20 Of course, as it has been underlined above, as Si is industrially easier to oxidize than SiGe, a Si layer on top of a SiGe layer (such as the Si film 3 on top of the relaxed SiGe layer 4) can help to initiate such an oxidation of a SiGe layer.

25 Hence a layer rich in germanium (enriched layer) is formed under the oxide layer, said enriched layer containing silicon when the oxidation is stopped before silicon is completely oxidized. A non oxidized layer of SiGe, and thus of unchanged germanium concentration, is generally under the aforementioned enriched layer, as the germanium atoms are mainly aggregated at the SiO_2/SiGe interface and not redistributed in the totality of the Si crystal.

30 A structure made of an oxide layer, a $\text{Si}_{1-z}\text{Ge}_z$ layer and generally a $\text{Si}_{1-r}\text{Ge}_r$ layer is therefore obtained, r representing the initial germanium concentration within the SiGe layer oxidized in this manner, and z representing the germanium concentration within said enriched layer, z being higher than x .

The figures 2a, 2b, 2c and 2d illustrate such a step of enrichment in germanium of a $\text{Si}_{1-r}\text{Ge}_r$ layer 6.

The enrichment step of such a layer 6 thus comprises an oxidation

operation of the aforementioned $\text{Si}_{1-r}\text{Ge}_r$ layer 6, possibly followed by a deoxidation operation for removing the oxide layer formed during the oxidation operation.

5 A heat treatment operation can also be carried out for homogenizing the concentration of germanium within the enriched layer.

The oxidation operation is a classical oxidation known to those skilled in the art. The oxidation operation is preferentially carried out at a temperature ranging between 700°C and 1100°C . It can be carried out by dry or wet process. Using dry process, oxidation is for instance carried out
10 by heating the substrate under gas oxygen. Using wet process, oxidation is carried out by heating the substrate in an atmosphere charged with steam.

Following this oxidation operation, and as it is represented on figure 2b, a surface oxide layer 9 is formed and a $\text{Si}_{1-z}\text{Ge}_z$ layer 8 enriched in germanium (z being higher than r) is underneath the oxide layer 9. Said
15 oxide layer 9 comprises mainly silica SiO_2 , but, according to various parameters such as for example:

- the oxidation operation conditions,
- the initial concentration r of germanium within the $\text{Si}_{1-r}\text{Ge}_r$ layer 6, or
- the initial thickness of the $\text{Si}_{1-r}\text{Ge}_r$ layer 6 thus oxidized,

20 a composite SiGe oxide ($\text{Si}_y\text{Ge}_t\text{O}_2$) oxide can be also formed.

Thus, for instance, only a low temperature wet oxidation operation leads to the formation of such a SiGe oxide ($\text{Si}_y\text{Ge}_t\text{O}_2$).

As it has been stated previously, if the oxidation operation takes only effect in a near surface area of the $\text{Si}_{1-r}\text{Ge}_r$ layer 6, a non oxidized $\text{Si}_{1-r}\text{Ge}_r$
25 layer 7, and thus of unchanged germanium concentration, is under the aforementioned enriched $\text{Si}_{1-z}\text{Ge}_z$ layer 8.

The deoxidation operation aims at removing the oxide layer 9 formed during the oxidation operation. The deoxidation operation is preferentially carried out in a traditional way. For this purpose, the substrate can be
30 plunged during a few minutes in a solution of hydrofluoric acid to 10% or 20% for example.

As it is represented on figure 2c, a structure made up of the aforementioned enriched $\text{Si}_{1-z}\text{Ge}_z$ layer 8 and, possibly, of said $\text{Si}_{1-r}\text{Ge}_r$
35 layer 7 of unchanged germanium concentration can be obtained next to said deoxidation operation.

Advantageously, the enrichment step comprises a heat treatment operation to allow the redistribution of the germanium atoms in the crystal of Si. Hence, the heat treatment step is adapted for obtaining a SiGe layer enriched in germanium and of homogeneous concentration in germanium.

Said heat treatment operation is preferably carried out at a temperature of approximately 1200°C.

Said heat treatment operation is carried out after the oxidation step and preferably prior to the deoxidation step.

5 However, said heat treatment operation can also be carried out after both oxidation and deoxidation steps.

In one embodiment of the invention, said enrichment step does not comprise a deoxydation operation. Thus the enriched SiGe layer is encapsulated by an oxide layer, avoiding, as mentioned above, a Ge
10 diffusion from it.

Figures 2a to 2d illustrate an enrichment step comprising, in the order, an oxidation operation, a deoxydation operation and a heat treatment operation. An enriched $\text{Si}_{1-k}\text{Ge}_k$ layer 11 (figure 2d) of homogeneous concentration k in germanium is thus formed, k being
15 comprised between the initial concentration r of the initial $\text{Si}_{1-r}\text{Ge}_r$ layer 6 and the concentration of said enriched $\text{Si}_{1-z}\text{Ge}_z$ layer 8.

Finally a light polishing, preferably a chemical-mechanical polishing (CMP), can be carried out in order to decrease the surface roughness and to improve the thickness uniformity of the enriched $\text{Si}_{1-k}\text{Ge}_k$ layer 11.

20 Of course several enrichment steps can be successively carried out in order to control as well as possible, and to increase significantly, the germanium concentration within the SiGe layer thus treated

Thus, thanks to such an enrichment step, the concentration of germanium within the SiGe layer 4 (underneath the preserved Si film 3
25 before said enrichment step; see figure 1e) can be increased, and more particularly can exceed the typical 30% limitation.

Such an increased germanium concentration can indeed reach 80% and is generally approximately 50%.

A second application of the invention implies, prior to any enrichment
30 step, a removal of the film 3 by a chemical way, as shown in Figure 1f.

To do this, it is preferred to use selective etching employing an etch solution exhibiting high selectivity with respect to the relaxed SiGe layer 4, such as a solution comprising at least one of the following compounds: KOH (potassium hydroxide), NH_4OH (ammonium hydroxide), TMAH (tetramethylammonium hydroxide), EDP (ethylenediamine / pyrocatechol /
35 pyrazine) or HNO_3 , or solutions currently under study combining agents such as HNO_3 , $\text{HNO}_2\text{H}_2\text{O}_2$, HF, H_2SO_4 , H_2SO_2 , CH_3COOH , H_2O_2 and H_2O , as explained in document WO 99/53539, page 9.

This second step makes it possible to retain good surface quality and

good thickness homogeneity of the relaxed SiGe layer 4.

Thus, a layer quality substantially identical to that obtained during its growth (shown in Figure 1c) is retained.

This is because this transferred layer 4 has not necessarily been
5 subjected to external mechanical stresses, such as those generated by a
CMP finishing step, thus avoiding the appearance of defects associated
with such stresses.

However, in certain particular cases, soft polishing is carried out in
order to remove any slight surface roughness.

10 Thus, a final relaxed SiGe-on-substrate structure is obtained, and in
particular a relaxed SiGe-on-insulator structure (also called an SGOI
structure) if the subjacent material of the relaxed SiGe layer 4 is an
electrical insulator.

In a particular embodiment of said second application of the invention,
15 an enrichment step can be carried out on said final relaxed
SiGe-on-substrate structure.

As it has been presented previously, such an enrichment step allows
to increase the germanium content within the relaxed SiGe layer 4 on top
of said SiGe-on-substrate structure.

20 In another particular embodiment, any epitaxy may be carried out on
the relaxed SiGe layer, such as epitaxy of another SiGe layer or epitaxy of
a strained Si layer.

In the latter case, an Si/SGOI final structure is obtained, the Si layer
being strained.

25 It has to be noticed that, when the structure has been subjected to
one or more enrichment steps, the germanium concentration within the
final relaxed SiGe layer is increased and can exceed the typical 30%
limitation.

Hence, the enrichment step helps to control the germanium
30 concentration within the final relaxed SiGe layer, and thus the lattice
parameter of such a layer. Finally, the strain exerted on a film epitaxially
grown on said relaxed SiGe layer can also be controlled.

In particular, a Si/SGOI final structure can be obtained, the Si film
being particularly strained.

35 Having completed the final structure, a finishing step may optionally
be carried out, such as finishing treatments like, for example, a heat
treatment in order to further strengthen the bonding interface with the
receiving substrate 5.

The present invention is not limited to an SiGe lattice parameter

matching layer 2, but also extends to a constitution of the matching layer 2 from other types of type III-V materials or other materials capable of straining the material of the epitaxially overgrown film 3.

5 The present invention is not limited to a film 3 of strained Si, but also extends to a constitution of it from other types of III-V materials or other materials capable to be strained by the underlying matching layer 2.

10 In the semiconductor layers, other constituents may be added thereto, such as carbon with a carbon concentration in the layer in question substantially less than or equal to 50% or more particularly with a concentration of less than or equal to 5%.

15 In addition, and in a similar way to what was described previously for the enrichment in germanium of a SiGe layer, as silicon Si also oxidizes selectively to carbon C, layers of semiconductor materials such as SiGeC alloys or Si_{1-y}C_y alloys, y being weak, can be enriched in their component carbon by oxidation.

20 Finally, the present invention does not relate only to transferring a relaxed SiGe layer 4, but in general relates to transferring a layer of any type of semiconductor able to be transferred according to a process of the invention.

CLAIMS

5 1. Method of producing a structure comprising a thin layer of semiconductor material obtained from a wafer (10), the wafer (10) comprising a lattice parameter matching layer (2) comprising an upper layer of a material chosen from semiconductor materials having a first lattice parameter, characterized in that it comprises the following steps :

10 (a) growth on the upper layer of the matching layer (2) of a film (3) of a material chosen from semiconductor materials, said grown film (3) being of a material having a nominal lattice parameter substantially different from the first lattice parameter, said grown film (3) having a thickness small enough to keep the first lattice parameter of the upper layer of the underlyed matching layer (2) and thus to be strained;

15 (b) growth on the film (3) of a relaxed layer (4), said relaxed layer (4) being of a material chosen from semiconductor materials comprising silicon and at least another element and having a nominal lattice parameter substantially identical to the first lattice parameter;

20 (c) removal of at part of the wafer (10) , comprising the following operations:

- formation of an embrittlement zone in the matching layer (2) ; and
- supply of energy in order to detach, at the embrittlement zone level, the part of the wafer (10) comprising the relaxed layer (4), thus forming the structure to produce;

25 (d) enrichment in an element other than silicon of the relaxed layer (4) comprised in the detached part of the wafer (10).

30 2. Method of producing a structure according to the preceding claim, characterized in that the enrichment step (d) comprises an oxidation operation of the detached part of the wafer (10) for forming an oxide layer on the surface of the thus oxidized detached part of the wafer (10) and increasing the concentration of the element other than silicon in a region of said relaxed layer (4) which is subjacent said oxide layer.

35 3. Method of producing a structure according to the preceding claim, characterized in that the enrichment step (d) further comprises a heat treatment operation for homogenising the concentration of the element other than silicon within said oxidized part of the wafer (10).

4. Method of producing a structure according to claim 2, characterized in that the enrichment step (d) further comprises a deoxidation operation for removing the oxide layer formed during said oxidation operation.

5

5. Method of producing a structure according to claim 4, characterized in that the enrichment step (d) further comprises a heat treatment operation for homogenising the concentration of the element other than silicon within said oxidized part of the wafer (10), said heat treatment operation being carried out either before or after said deoxydation operation.

10

6. Method of producing a structure according to the preceding claim, characterized in that the heat treatment operation is carried out at a temperature of approximately 1200°C.

15

7. Method of producing a structure according to any one of the preceding claims, characterized in that, after step (b), an additional step is carried out in which a receiving substrate (5) is bonded to the wafer (10) on the relaxed layer (4) side.

20

8. Method of producing a structure according to the preceding claim, characterized in that the receiving substrate (5) is made of silicon.

9. Method of producing a structure according to any one of the two preceding claims, characterized in that, before bonding, a step of forming at least one bonding layer between the receiving substrate and the wafer (10) is furthermore carried out, the bonding layer being formed on the receiving substrate (5) and/or on the bonding face of the wafer (10).

25
30

10. Method of producing a structure according to the preceding claim, characterized in that the bonding layer is an electrically insulating material.

11. Method of producing a structure according to the preceding claim, characterized in that the bonding layer is made of silica.

35

12. Method of producing a structure according to the preceding claim, characterized in that the bonding layer is formed by thermal oxidation.

13. Method of producing a structure according to one of the preceding claims, characterized in that the embrittlement zone is formed by implantation of species into the matching layer (2) at a depth substantially equal to the implant depth.

14. Method of producing a structure according to one of claims 1 to 11, characterized in that, before step (b), the embrittlement zone is formed by porosification of a layer beneath the relaxed layer (4).

15. Method of producing a structure according to one of the preceding claims, characterized in that the removal step (c) comprises, after the energy supply operation of step (c), at least one selective etching operation.

16. Method of producing a structure according to the preceding claim, characterized in that a selective etching operation relates to the etching of the remaining part of the matching layer (2) with respect to the film (3) (after detachment of the wafer (10) by energy supply).

17. Method of producing a structure according to the preceding claim, characterized in that it further comprises after said etching operation and before the enrichment step (d) a growth of a film of a material chosen from semiconductor materials on the film (3), said semiconductor material being substantially the same as the one of the film (3).

18. Method of producing a structure according to any of the two preceding claims, characterized in that it further comprises an oxidation of the film (3).

19. Method of producing a structure according to the preceding claim, characterized in that an annealing treatment is operated at the same time or following the oxidation, this annealing treatment being able to strengthen the bonding interface.

20. Method of producing a structure according to the claims 14 or 15, characterized in that a selective etching operation relates to the etching of the film (3) with respect to the relaxed layer (4).

21. Method of producing a structure according to one of the preceding claims, characterized in that it furthermore comprises, after step (d), a step of growing a layer on the relaxed layer (4).

5 22. Method of producing a structure according to the preceding claim, characterized in that the growth layer on the relaxed layer (4) is made of strained material.

10 23. Method of producing a structure according to any one of the preceding claims, characterized in that:

- the matching layer (2) is made of silicon-germanium, the matching layer (2) comprising a buffer layer with a germanium concentration which increases through the thickness and a relaxed layer beneath the film (3);

15 - the film (3) of strained material is made of silicon;

- the element other than silicon is germanium Ge so that the relaxed layer (4) is made of substantially relaxed silicon-germanium, with a germanium concentration substantially equal to the germanium concentration of the relaxed layer of the matching layer (2).

20

24. Method of producing a structure according to any one of the claims 1 to 21, characterized in that the element other than silicon in the relaxed layer (4) is carbon C.

25 25. Method of producing a structure according to any one of the claims 1 to 21, characterized in that the element other than silicon in the relaxed layer (4) is an alloy germanium-carbon.

30 26. Method of producing a structure according to claim 22 and one of the claims 23 to 25, characterized in that the growth layer produced on the relaxed layer (4) is made of strained silicon so as to substantially preserve the lattice parameter of the subjacent relaxed layer (4).

35 27. Method of producing a structure according to one of the preceding claims, characterized in that the wafer (10) comprises at least one layer furthermore containing carbon with a carbon concentration in the layer substantially less than or equal to 50%.

28. Method of producing a structure according to one of the preceding claims, characterized in that the wafer (10) comprises at least one layer furthermore containing carbon with a carbon concentration in the layer substantially less than or equal to 5%.

5

29. Structure obtained after the enrichment step (d) of the method according to claim 7 and any one of claims 8 to 29, comprising in succession at least the receiving substrate (5) and the relaxed layer (4) comprised in the detached part of the wafer (10) and enriched in its element other than silicon, characterized in that said relaxed layer (4) has a lattice parameter substantially superior to said first lattice parameter.

10

30. Application of the method according to claims 1 to 29, to the production of one of the following "semiconductor on insulator" structures :
SGOI ; strained Si / SGOI, SiGe / strained Si / SGOI ; SiO₂ / SGOI.

15

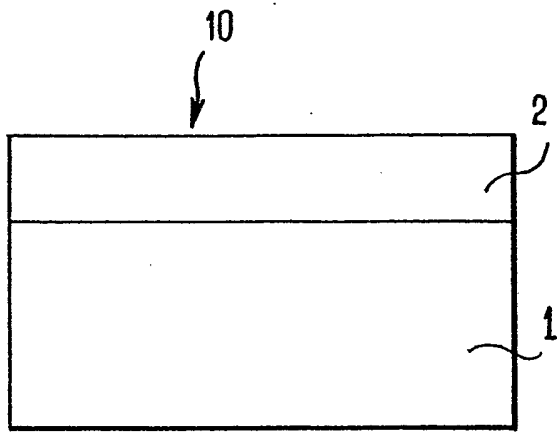

FIG. 1a

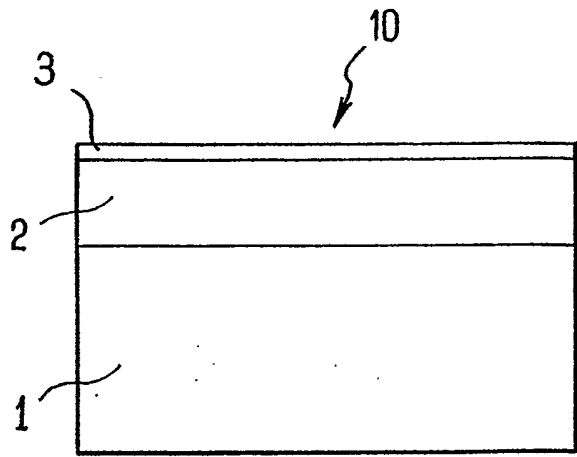

FIG. 1b

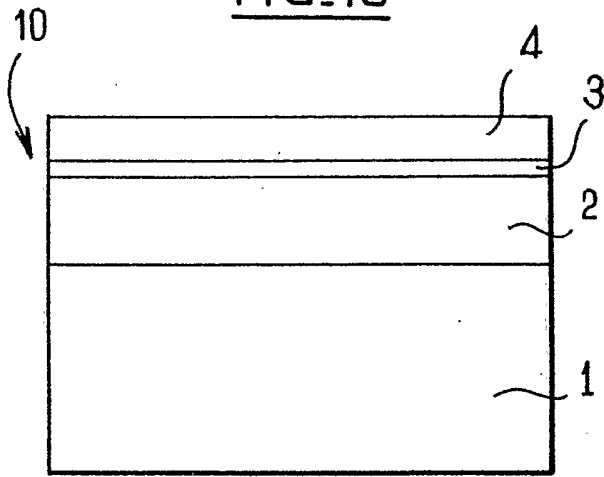

FIG. 1c

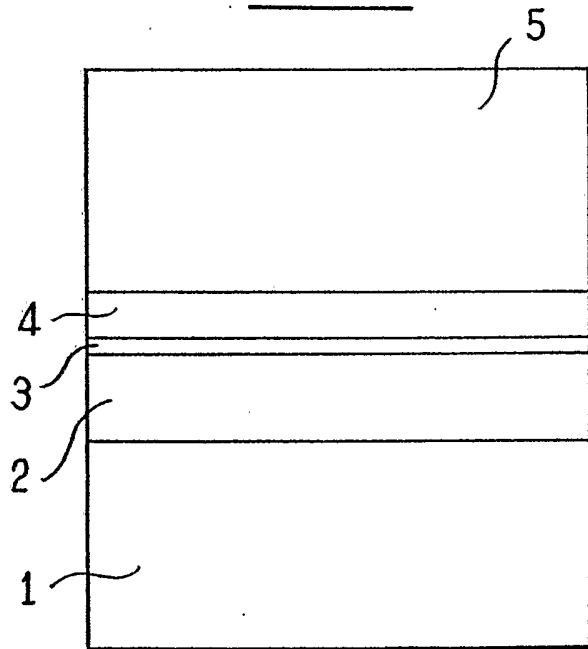

FIG. 1d

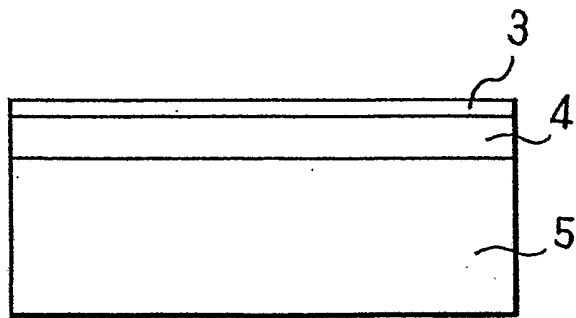

FIG. 1e

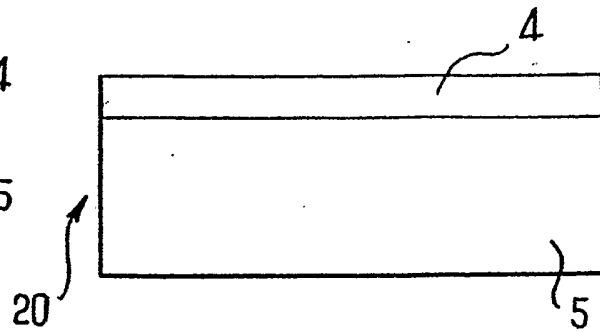

FIG. 1f

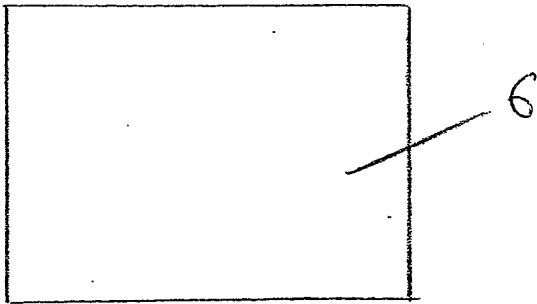

Fig. 2a

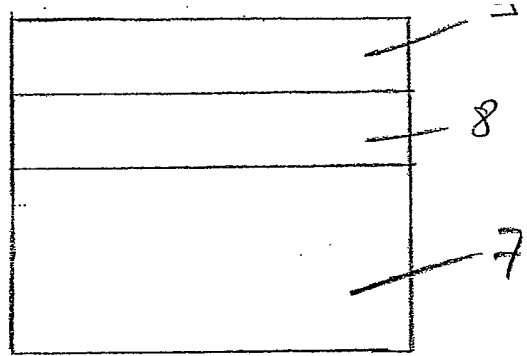

Fig. 2b

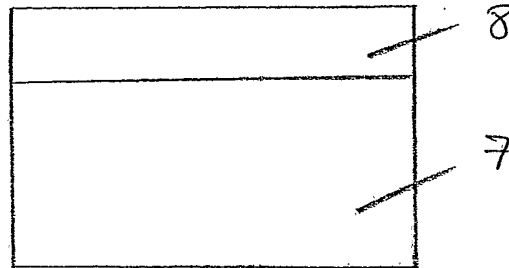

Fig. 2c

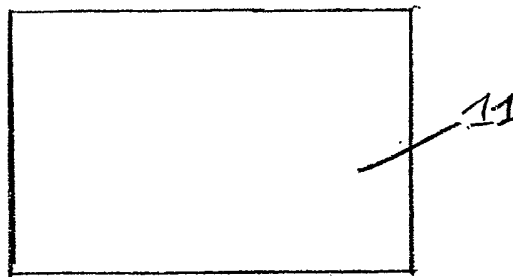

Fig. 2d