

March 24, 1942.

D. C. LAMB

2,277,332

COLLAPSIBLE COSTUMER

Filed April 4, 1940

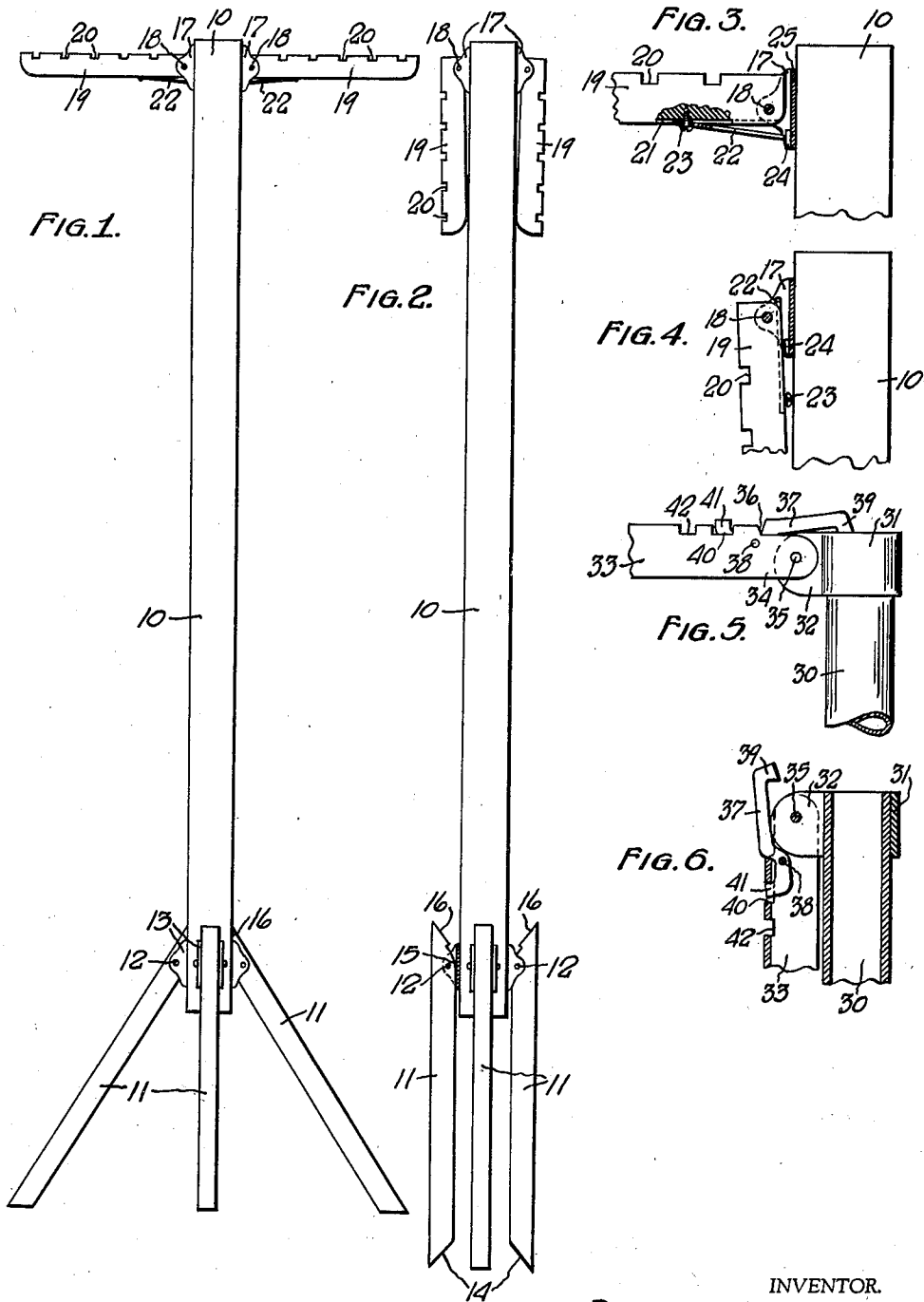

BY

INVENTOR.  
**DAVID C. LAMB.**  
*Olteck & Knublock*  
ATTORNEYS.

# UNITED STATES PATENT OFFICE

2,277,332

## COLLAPSIBLE COSTUMER

David C. Lamb, Nappanee, Ind., assignor to  
Goshen Cushion & Body Co., Goshen, Ind., a  
corporation of Indiana

Application April 4, 1940, Serial No. 327,798

3 Claims. (Cl. 211-178)

This invention relates to a collapsible costumer, and has for its primary object to provide a costumer which may be collapsed into compact compass for storage and shipping purposes, and which may be extended to operative position with the parts positively but releasably supported.

A further object is to provide a novel, simple and inexpensive costumer.

A further object is to provide a costumer having a post or standard to which are pivotally connected feet and arm members all arranged to be selectively extended in operative position or pivoted into substantially parallel relation to the post.

A further object is to provide a costumer having arms pivotally mounted on a standard and adapted to fold downwardly into substantially parallel relation alongside the standard, and provided with means for releasably locking the arms in substantially perpendicular relation to the standard in a manner to sustain the weight of objects hung thereon.

Other objects will be apparent from the description and appended claims.

In the drawing:

Fig. 1 is a side elevation of the costumer in extended or operative position.

Fig. 2 is a side elevation of the costumer in collapsed position.

Fig. 3 is an enlarged fragmentary detail view of the upper end of the costumer with an arm in extended position, wherein parts are shown in cross section.

Fig. 4 is an enlarged fragmentary detail view illustrating the arm in collapsed position, with parts shown in section.

Fig. 5 is an enlarged fragmentary detail view of a modified embodiment of the invention.

Fig. 6 is a longitudinal sectional view illustrating the modified embodiment of Fig. 5 in collapsed position.

Referring to the drawing which illustrates the preferred embodiments of the invention, the numeral 10 designates a post or standard of suitable length and cross section. A plurality of leg members 11 are pivoted at 12 to brackets 13 fixedly secured to the sides of standard 10 adjacent the lower end thereof. Brackets 13 are preferably of U-shape with the legs 11 seated between the legs of the U. The lower ends of the legs are beveled at 14 and the upper ends thereof are preferably curved at 15 substantially concentric with pivot 12. The major portion of the upper end of the legs 14 is beveled at 16 in offset relation with reference to the curve 15.

From the above, it will be seen that the leg members 11 may be positioned in collapsed substantially parallel relation to the rod 10 as illustrated in Fig. 2 for shipping or storage. In operative position, the legs are extended at an angle to the post 10, with the offset portion 16 thereof in flat face engagement with the post above the bracket 13. If desired, the base of the bracket 13 may be extended, in which event the offset nature of the upper beveled face of each leg member is eliminated, the bevel in that case seating directly against said plate. The curve 15 obviously accommodates the pivoting of the leg members 11 when the latter are positioned close to the base of the bracket 13 as best illustrated in Fig. 2.

U-shaped brackets 17 are mounted at the upper end of post 10, and have arms 19 pivoted thereto at 18. The arms 19 are preferably elongated and provided with substantially equi-spaced notches 20 at their upper edges. The lower inner face of each arm 19 is provided with a groove 21 extending longitudinally thereof and adapted to receive an elongated metal bar 22 which is loosely secured to the arm 19 by means of a screw 23. The bar 22 is of such a length that it preferably projects slightly beyond the inner end of the arm 19 and is adapted to bear against a suitable offset 24 carried by the base 25 of bracket 17 slightly below the bottom surface of arm 19. The screw 23 is so positioned as to permit a certain maximum amount of angular displacement of the bar 22 with reference to the arm 19.

Hence, assuming that the arm 19 is in collapsed position as illustrated in Figs. 2 and 4, and is to be shifted to extended supporting position, the arm 19 is swung upwardly to a position slightly above operative position, whereupon the bar 22 rides outwardly over and clear of the upper edge of the stop 24, so that subsequent downward pivoting of the arm 19 will cause the inner end of bar 22 to engage the outer face of the stop 24 and thus serve to hold the arm 19 in operative extended position. To collapse the arm 19, it is merely necessary to slightly upwardly swing the arm 19 to disengage bar 22 from stop 24 and then push the bar 22 into its receiving groove 21, whereupon the arm 19 may be freely swung downwardly to desired collapsed position.

A modified embodiment of the invention is illustrated in Figs. 5 and 6, wherein the post or upright 30 comprises a hollow metal tube. A sleeve or clamp 31 is secured to the upper end of post 30 and is provided with cooperating outwardly projecting ears 32. Arm 33, preferably of in-

verted U-shape in cross section, has end portions 34 thereof pivoted to the ears 32 at 35. End portions 34 constitute a pair of spaced parallel plates of reduced width as compared to arm 33, whereby a shoulder 36 is formed in the arm 33 adjacent the inner end thereof. A suitable latch 37 is pivoted at 38 intermediate its ends and between the portions 34 of the arm. One end of the latch 37 is positioned in outwardly off-set relation to said pivot and is provided with a perpendicularly directed catch 39 at its end. The upper edge of arm 33 is notched at 40 in outwardly spaced relation to the pivot 38, and a finger piece 41 extending perpendicularly outwardly from the outer end of the latch 37 is adapted to move within said notch. Other notches 42 may be formed in the upper edge of the arm 33 for the same purpose as notches 20 in the preferred embodiment.

In this embodiment, the inner portion of the latch 37 extends clear of the plates 34, ears 32, sleeve 31 and the end of the post 30 when the arm 33 is in operative position perpendicular to said post. Hence the catch 39 of said member is free to extend within the post 30 and is positioned for engagement of its inner edge with the inner surface of the adjacent portion of the post 30, whereby it serves to lock the arm 33 in operative position perpendicular to post 30. When the latch 37 is thus operatively positioned, the finger piece 41 projects through the notch 40 of arm 33 to be readily accessible. To collapse the arm 33, it is only necessary to depress the finger piece 41, thereby withdrawing the latch 39 from within the post 30, followed by downward swinging of the arm alongside post 30. The latch is held in operative position when the arm is collapsible by virtue of its engagement with the shoulder 36 of the arm. One advantage of this construction is that the latch element 37 will assume a locking position by gravity when the arm 33 is swung to operative position as will be obvious.

In each of these constructions, means is provided for firmly positioning the arms 19 and 33 respectively, in such a manner that they may

support the weight of a plurality of garments mounted on hangers suspended from the arms at the notches 20 and 42. Hence the costumer, when the arms are of substantial length, may accommodate a large number of garments. The collapsible character of the costumer facilitates its shipping and storage and does not detract from its strength. Hence the construction of this costumer has great utility in use, which is of substantial advantage as compared to conventional rigidly constructed devices of this character.

I claim:

1. In a costumer, a tubular upright, an arm of U-shaped cross section, a bracket carried by the upper end of said upright and pivotally mounting said arm at one end, an elongated latch pivoted within said arm and projecting longitudinally from the inner end of said arm, said latch terminating in a hook portion insertable within said tube in engagement with the adjacent portion of the wall of said tube, said latch having a finger piece at its opposite end projecting transversely outwardly from said arm through an opening therein.

2. The combination defined in claim 1, wherein said arm is positioned with the base of said U positioned upwardly when said arm is extended and the pivoted end of said arm is forked to accommodate positioning of at least a part of said latch exteriorly of the outline of said arm.

3. In combination, a support having a socket, an arm of inverted U-shaped cross section having parallel ears projecting from one end thereof, means pivotally connecting said ears to said support at predetermined points thereof, and a latch positioned within said arm and pivoted thereto inwardly of the pivots of the ears, an upwardly offset portion of said latch projecting beyond said ears and having a hooked end for releasable engagement with the edge of said socket to hold said arm in horizontal position, said arm depending from said pivot means when said latch is released.

DAVID C. LAMB.