

J. R. KINNEY.  
ROTARY PUMP.

APPLICATION FILED DEC. 21, 1908. RENEWED NOV. 20, 1911.

1,031,072.

Patented July 2, 1912.

2 SHEETS-SHEET 1.

Fig. 1.

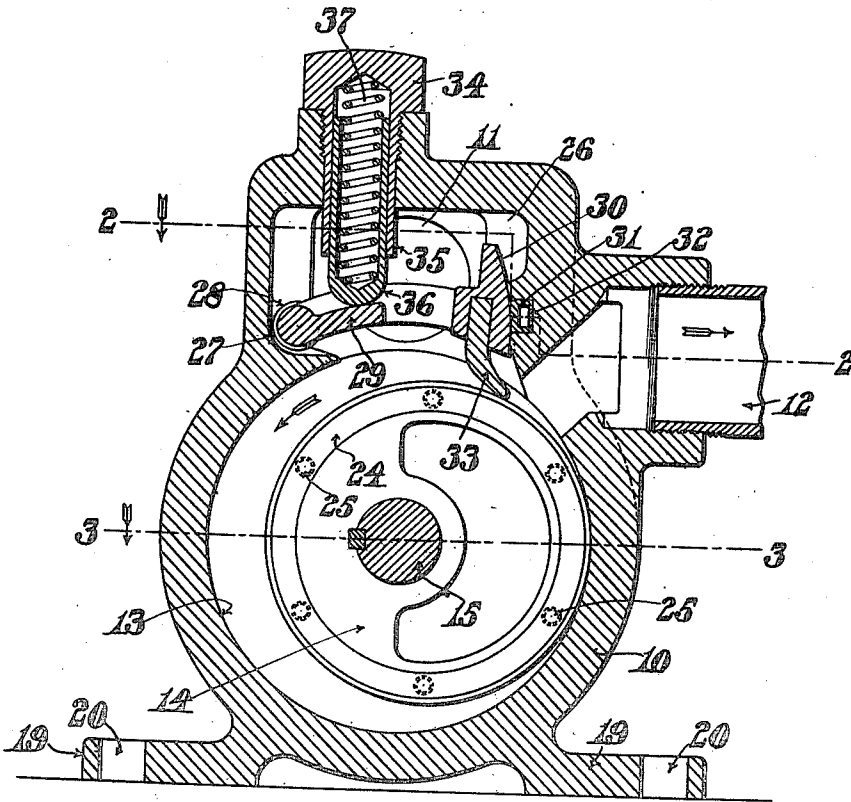

Witnesses:

Howard Hanson  
Nathan L. Lombard

Inventor:

Justus R. Kinney,  
by Walter C. Lombard,  
Atty.

J. R. KINNEY.

ROTARY PUMP.

APPLICATION FILED DEC. 21, 1908. RENEWED NOV. 30, 1911.

1,031,072.

Patented July 2, 1912.

2 SHEETS—SHEET 2.

Fig. 2.

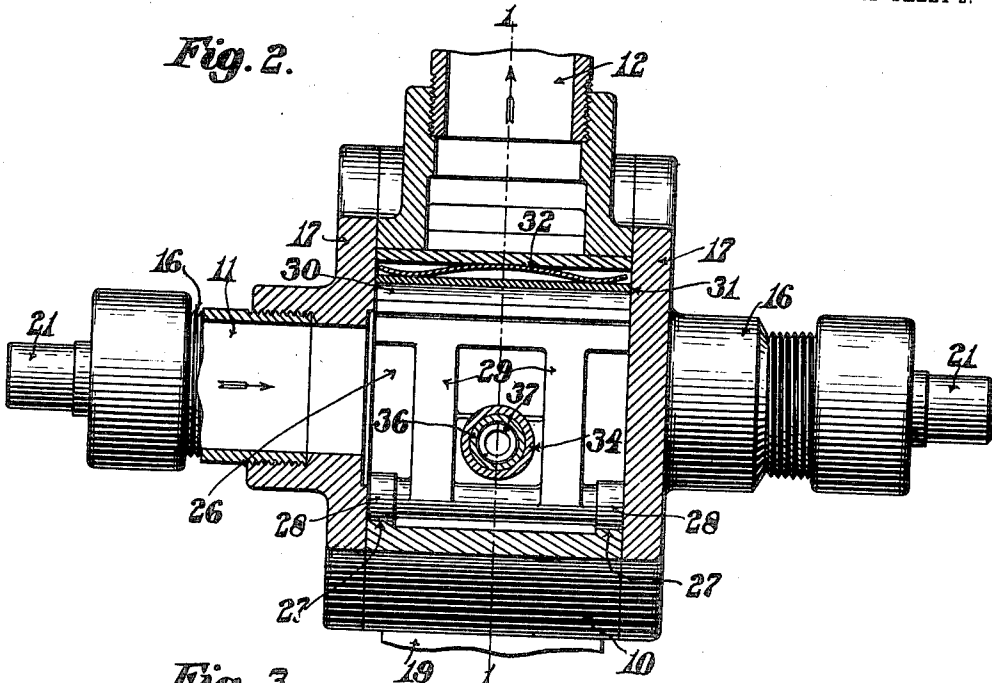
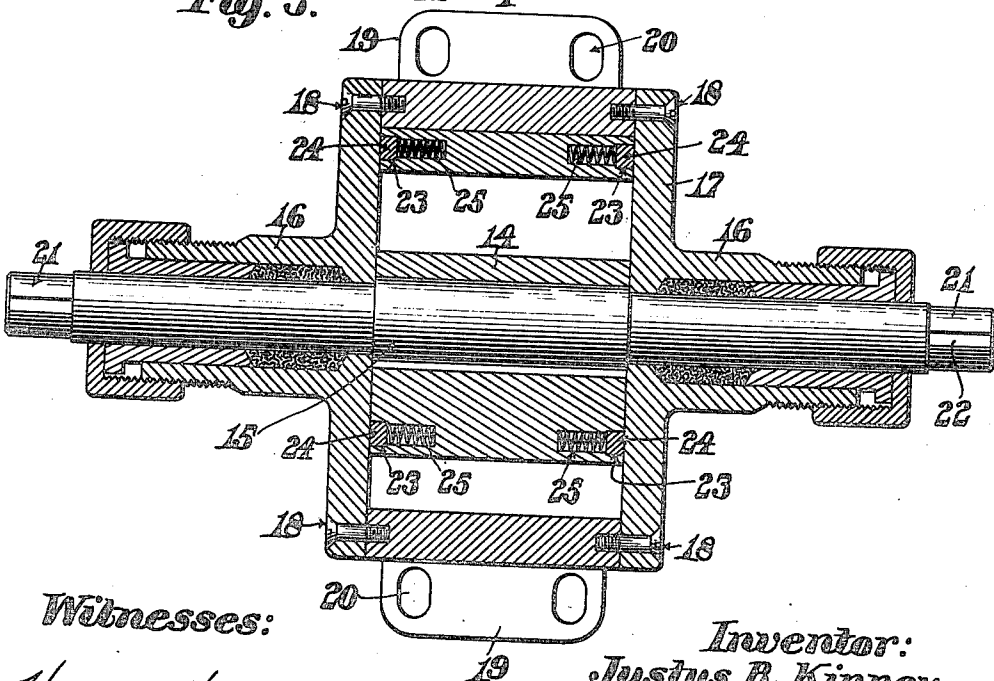

Fig. 3.



Witnesses:

Howard Hanson  
Nathan B. Lombard

Inventor:

Justus R. Kinney,  
by Walter E. Lombard,  
Atty.

# UNITED STATES PATENT OFFICE.

JUSTUS R. KINNEY, OF DORCHESTER, MASSACHUSETTS.

## ROTARY PUMP.

1,031,072.

Specification of Letters Patent.

Patented July 2, 1912.

Application filed December 21, 1908, Serial No. 468,658; Renewed November 20, 1911. Serial No. 661,422.

*To all whom it may concern:*

Be it known that I, JUSTUS R. KINNEY, a citizen of the United States of America, and a resident of Dorchester, in the county of Suffolk and State of Massachusetts, have invented certain new and useful Improvements in Rotary Pumps, of which the following is a specification.

This invention relates to rotary pumps and has for its object the production of a simple and effective means for retaining a pivoted blade in contact with the periphery of the piston under any desired tension.

The invention consists in certain novel features of construction and arrangement of parts which will be readily understood by reference to the description of the drawings and to the claims hereinafter given.

Of the drawings: Figure 1 represents a vertical section of a pump embodying the features of this invention, the cutting plane being on line 1—1 on Fig. 2. Fig. 2 represents a horizontal section, the cutting plane being on line 2—2 on Fig. 1, and Fig. 3 represents a horizontal section, the cutting plane being on line 3—3 on Fig. 1.

Similar characters designate like parts throughout the several figures of the drawings.

In the drawings, 10 represents the casing of a pump embodying the features of this invention provided with the inlet 11 and the outlet 12 while the interior thereof is provided with a chamber 13. In the chamber 13 is mounted an eccentric piston 14, this piston being keyed to a shaft 15 mounted in suitable packed bearings 16 formed upon the end plates 17 secured to the main casing 10 by means of a plurality of screws 18.

The casing 10 is provided with the flanges 19 having openings 20 therein by which the pump may be secured in position. The shaft 15 is provided with reduced ends 21 having splines or key-ways 22 by which any suitable pulley or gear (not shown) may be secured to the shaft for the purpose of driving the same. Each side wall of the piston 14 is provided with an annular groove 23 in which is mounted a packing ring 24 forced outwardly against the inner face of the end plates 17 by a plurality of springs 25 each inserted in a hole in the piston 14. The casing 10 is also provided with a chamber 26 communicating with the piston chamber 13. Within and at each side of the chamber 26 the casing 10 is provided

with a seat 27 in each of which is adapted to rest an enlarged cylindrical end or trunnion 28 of a member 29, these cylindrical ends or trunnions forming a suitable pivot about which said member may be moved within the chamber 26, the opposite end of said member being provided with a surface 30 concentric to the axis of said ends 28. This surface 30 bears against a concentric surface formed upon the inner wall of said chamber 26 and is securely packed at this point by means of the packing member 31 forced outwardly into contact with the surface 30 by means of the spring 32.

The free end of the member 29 is provided with a blade 33 the outer end of which is formed at an angle to the main part thereof so that the surface which contacts with the surface of the piston 14 is substantially tangential to said periphery. Mounted in the casing 10 above said blade 29 is a chambered bolt 34 threaded to the casing 10 so that it may be adjusted longitudinally. The inner end of the bolt 34 is tubular as at 35 and within the cylindrical chamber of said bolt is mounted a cylindrical chambered plunger 36, the chamber of which contains a spring 37 which is adapted to force said plunger outwardly into contact with the member 29 to insure positive contact at all times between the blade 33 and the periphery of the piston 14. It is obvious that by turning the bolt 34 in either direction the tension of the spring 37 may be varied to suit varying conditions in the operation of the pump.

The member 29 is of open construction so that the water or other material being pumped may pass from the inlet pipe 11 through the blade 29 of the chamber 13 and be forced by the revolution of the piston 14 through the outlet pipe 12, the spring 37 acting upon the member 29 to retain the blade 33 in contact with the periphery of the piston 14 during this operation so as to prevent any leakage at this point.

A better result is found to be obtained by making the contacting portion of the blade 33 substantially tangential to the periphery of the piston 14, any tendency of the liquid to pass by the blade 33 back into the inlet chamber 26 being overcome by the action of the liquid upon the tangential portion of the blade 33 to retain it in firmer contact.

The provision of the seat 27 in which the member 29 rests without necessitating the

provision of any bearings for the pivots of said member simplifies the construction of the pump quite materially and overcomes many difficulties in its operation and any tendency for the liquid to leak through the parts where such are provided.

The construction of the spring plunger mechanism for retaining the blade 33 in contact with the periphery of the piston is such as to make it very effective in its operation and adapted for adjustment to vary the tension of the spring as desired.

It is obvious that the device described and shown may be used equally as well as a motor by admitting a motive agent to the piston chamber and causing a rotation of the same, power being taken from the revoluble shaft of said piston.

It is believed that from the foregoing the operation and many advantages of the invention will be fully understood without further description.

Having thus described my invention, I claim:

1. In a device of the class described, the combination of a casing having a cylindrical chamber; a revoluble shaft centrally positioned therein; a cylindrical piston eccentrically mounted on said shaft with one portion of its periphery in contact with the wall of said chamber; an inlet chamber one wall of which is provided with a pair of alined shallow seats; a pivoted blade within said inlet chamber and provided with two alined cylindrical projections normally resting in said seats; an inlet passage through said blade connecting said inlet chamber with

said piston chamber; a member threaded to said casing opposite said pivoted blade and provided with a cylindrical chamber; and a spring-pressed plunger in said chamber provided with a semi-spherical end bearing upon a flat face of said pivoted blade and retaining it in its seat and in contact with said rotary piston.

2. In a device of the class described, the combination of a casing having a cylindrical chamber; a revoluble shaft centrally positioned therein; a cylindrical piston eccentrically mounted on said shaft with one portion of its periphery in contact with the wall of said chamber; an inlet chamber one wall of which is provided with a pair of alined shallow seats; a pivoted blade within said inlet chamber and provided with two alined cylindrical projections normally resting in said seats; an inlet passage through said blade connecting said inlet chamber with said piston chamber; a member threaded to said casing opposite said pivoted blade and provided with a cylindrical chamber; a tubular plunger in said chamber provided with a semi-spherical end bearing upon a flat face of said pivoted blade and retaining it in its seat and in contact with said rotary piston; and a spring in said tubular plunger bearing against the inner end of said chamber.

Signed by me at 4 Post Office Sq., Boston, Mass., this 14th day of December, 1908.

JUSTUS R. KINNEY.

Witnesses:

EDNA C. CLEVELAND,  
WALTER E. LOMBARD.