

(No Model.)

3 Sheets—Sheet 1.

J. B. MAYER.
ELECTRIC SWITCHBOARD.

No. 473,848.

Patented Apr. 26, 1892.

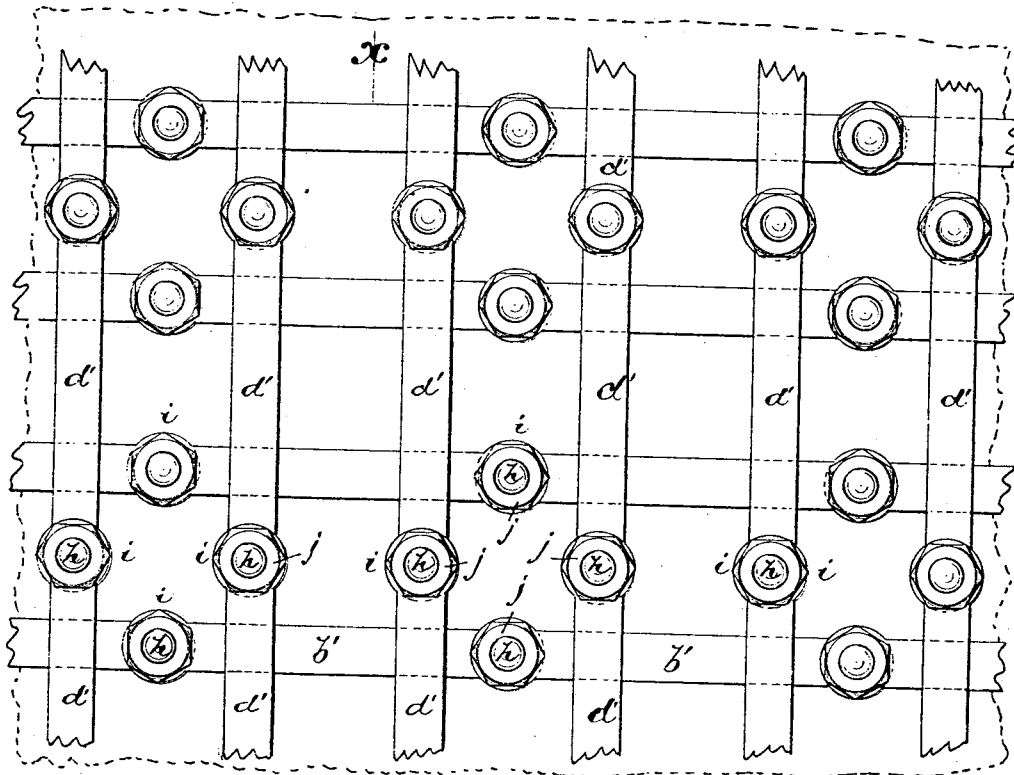

Fig. 1.

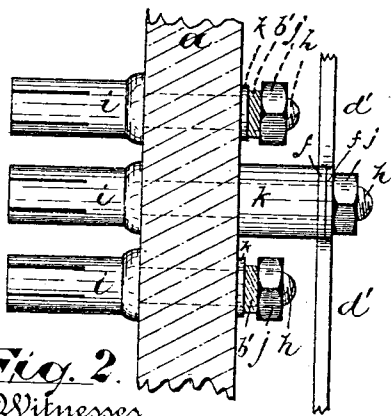

Fig. 2.

Witnesses

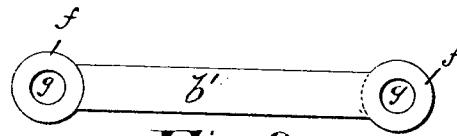

Fig. 3.

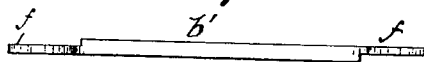

Fig. 4.

Inventor

Oscar A. Michel.
E. Sgler

John B. Mayer,

By *Draker & Co.* Attys.

(No Model.)

3 Sheets—Sheet 2.

J. B. MAYER.
ELECTRIC SWITCHBOARD.

No. 473,848.

Patented Apr. 26, 1892.

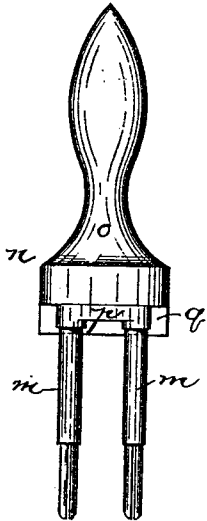

Fig. 6.

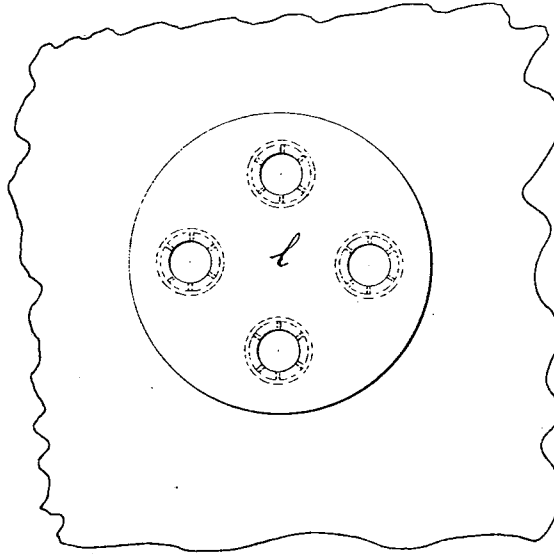

Fig. 5.

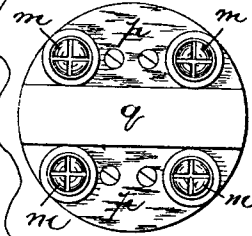

Fig. 7.

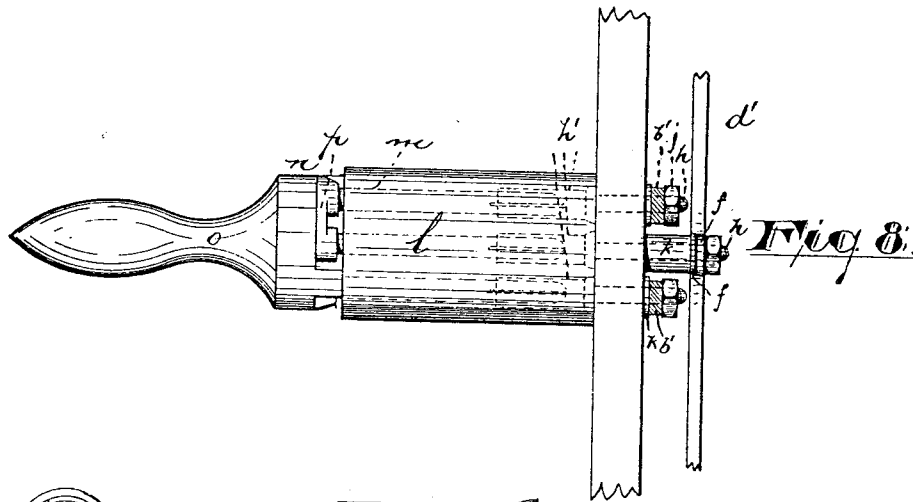

Fig. 8.



Fig. 9.
Witnesses



Fig. 10.

Inventor:

Oscar A. Michel
E. Sgler

John B. Mayer.

By *Draket Co.* Atty's.

(No Model.)

3 Sheets—Sheet 3.

J. B. MAYER.
ELECTRIC SWITCHBOARD.

No. 473,848.

Patented Apr. 26, 1892.

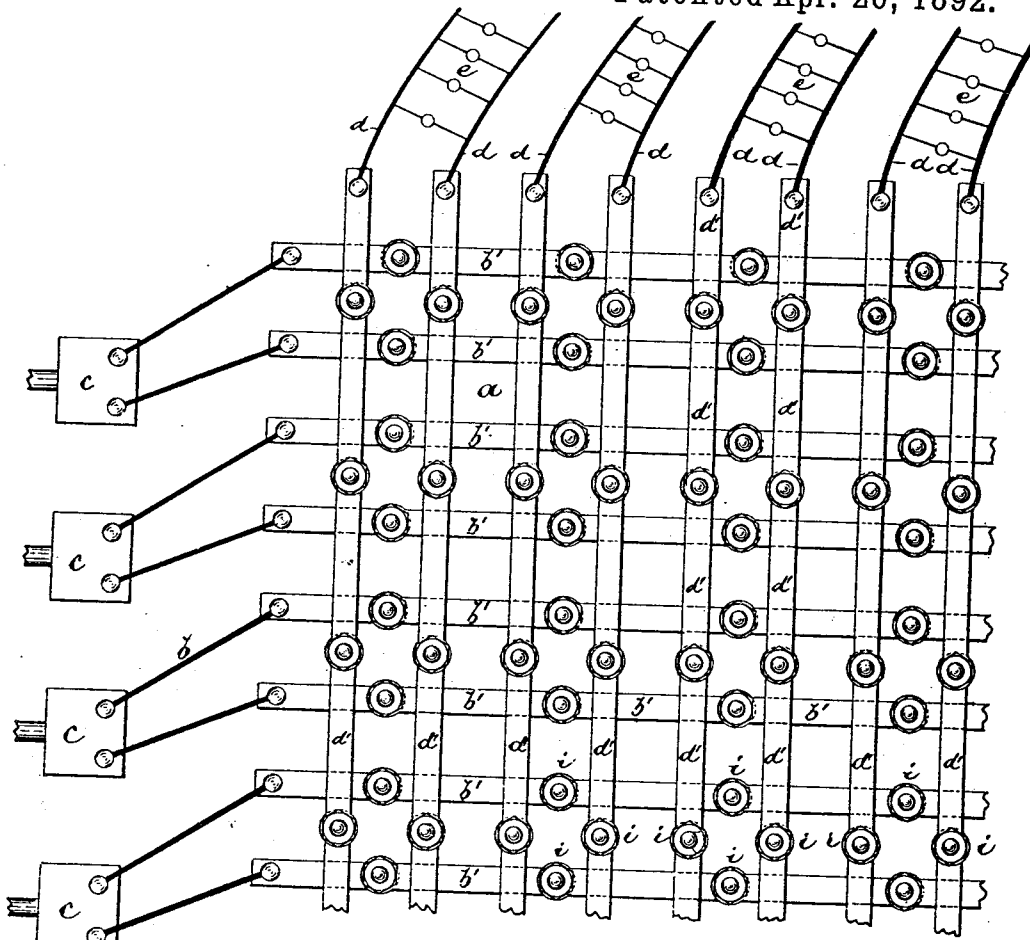

Fig. 11.

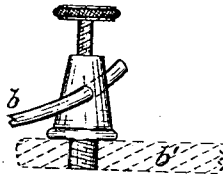

Fig. 12.

Witnesses

Inventor

Oscar A. Michel.
E. Iglar

John B. Mayer,

By Drake & Co. Atty's.

UNITED STATES PATENT OFFICE.

JOHN B. MAYER, OF NEWARK, NEW JERSEY, ASSIGNOR OF ONE-HALF TO JOSEPH MEIER, OF SAME PLACE.

ELECTRIC SWITCHBOARD.

SPECIFICATION forming part of Letters Patent No. 473,848, dated April 26, 1892.

Application filed May 11, 1891. Serial No. 392,274. (No model.)

To all whom it may concern:

Be it known that I, JOHN B. MAYER, a citizen of the United States, residing at Newark, in the county of Essex and State of New Jersey, have invented certain new and useful Improvements in Electric Switchboards; and I do hereby declare the following to be a full, clear, and exact description of the invention, such as will enable others skilled in the art to which it appertains to make and use the same, reference being had to the accompanying drawings, and to letters of reference marked thereon, which form a part of this specification.

The objects of this invention are, first, to secure a more compact arrangement of parts, whereby room is saved on the switchboard and the size of the latter may be reduced; second, to secure greater safety against burning out the terminals owing to the electric current following the plug when a break is being made in transferring the current of a given dynamo-machine from one set of lamps to another set to enable any desired combination between the dynamo-machines and the lamp to be made to reduce the cost of construction and secure greater safety in handling the switches, and to obtain other advantages and results, some of which will be described in connection with the description of the working parts.

Referring to the accompanying drawings, in which like letters indicate corresponding parts in each of the several figures, Figure 1 is a rear elevation of a portion of a switchboard. Fig. 2 is a section of the same, taken on line *x*. Figs. 3 and 4 are detail views of certain switchboard connections, which will be described. Fig. 5 is a front elevation of a portion of a switchboard, showing in detail one of a series or collection of connecting-plug receivers. Fig. 6 is a detail side elevation, and Fig. 7 an end view, of the connecting-plug. Fig. 8 is a side view showing the connecting-plug in the receiver and making connection between the dynamo-machine wires and the lamp-wires. Figs. 9 and 10 are respectively an end view and a side view of a terminal forming a part of the plug-receiver. Fig. 11 is a diagram showing the general arrangement of parts in the system; and

Fig. 12 is a detail showing a binding-post, by means of which the conducting-wires are joined to the connections of the switchboard.

In said drawings, *a* indicates a suitable switchboard, which may be of stone or other non-inflammable material, slate being preferred.

b b are the lines connecting with the dynamo-electric machines *c c*, and *d d* indicate the lines connecting with the lamps *e e* in any ordinary manner. The said lines or connections where arranged on the switchboard are preferably in sections and in the form of links *b' d'*, as shown in detail in Figs. 3 and 4. By this construction the assemblage of parts may be facilitated, and the connections can be more readily and easily adjusted in relation to the plug-receiving terminals.

The link-like connections are attached to the wires of the dynamo-machines and of the lamps by binding-posts. (Shown in Fig. 12 in detail, or in any other suitable manner.)

The dynamo-machine connections on the board are arranged at an angle to the lamp connections, as shown in Figs. 1 and 11, the positive and negative wires or connections of one set crossing the positive and negative wires of the other set at right angles, as shown. The link-like connections are provided at their ends with eyes *f*, which overlap, and the perforations *g* coincide and receive the shanks *h* of the plug-receiving terminal *i*, the said eyes being held onto the shanks by nuts *j* or other appropriate means.

The links are held away from the board *a* by washers *k*, which are of greater thickness or length in one series of connections than in the other, as will be understood upon reference to Figs. 2 and 8, to hold the same apart or away from electrical contact with one another.

The terminals employed are preferably of the construction shown in Fig. 10, where the portion *h'*, which lies at the front of the board and receives the plug, is shown to project from the face of the board. It is in the form of a socket, which may be split to give a certain spring action and enable a more perfect and certain contact with the plug. The projecting plug-receiving terminals are arranged

in groups of four, one pair being in connection with the positive and negative connections with the dynamo-electric machine and the other pair being in connection with the negative and positive connections with the lamps. Said projecting terminals are covered by non-combustible insulation *l*, which is in the form of a perforated block, the perforations being in the line of the said terminals, and the latter extending a short distance into said perforations, as shown in Fig. 8, so that the point of contact is considerably back from the forward face of the block.

The plug *n* consists, preferably, of a handle *o*, having at one end thereof pairs of arms *m*, the arms of each pair having metallic connections, as at *p*, which serve as bearings to hold the arms in proper relative position on the handle. The arms at their extremities may also be split, as indicated in Fig. 6, to secure a spring action and more perfect contact.

The handle *o*, which is of non-conductive material, is preferably provided between the connections *p* with a ridge *q*, which serves to insulate the two sets of connections from one another and preventing short-circuiting.

By terminating the projecting terminals considerably back from the face of the block *l* there is an air-space or distance between the extremities and over the partition-walls, amounting in practice to seven inches, more or less, over which the current will have to arch before making a short circuit and burning the terminals, although the centers of the terminals are only an inch or two laterally distant from one another in each group.

By the construction described, because of the crossing of all the wires of the plurality of the dynamo-machines over those of the lamps and the grouping of the terminals in the manner shown, any one of the dynamo-machines may be brought into connection with any of the lamp-wires by simply transferring the plug or one of the plugs to the desired crossing, making the proper combination.

Having thus described the invention, what I claim as new is—

1. The improved electrical switchboard for electrical-lighting systems herein described, combining with a board *a* a series of crossing dynamo-machine and lamp connections *b' b' d' d'*, each having plug receivers or terminals *i* open or exposed at the front of the board and forming groups of four, each group having negative and positive terminals in connection with the lamp and dynamo-machine circuits or connections, insulating material

extending between and beyond the extremities of said terminals of each group, and a plug having four projecting arms arranged in pairs, one pair being insulated from the other, and said arms being adapted to enter into or be withdrawn from contact with the said four terminals simultaneously, substantially as and for the purposes set forth.

2. The improved electrical switchboard for electrical-lighting systems herein described, combining with a board *a* a series of crossing dynamo-machine and lamp connections *b' b' d' d'*, each of said connections having terminals consisting of projecting sockets *h'*, split to secure a spring action, and threaded shanks *h*, which receive the said connections, and nuts for holding the parts together, insulating material interposed between said sockets, and a plug having two pairs of insulated arms, all said parts being arranged and combined substantially as set forth.

3. In a switchboard, the combination, with the connections *b' d'*, of sockets *h' h'*, projecting from the board and inclosed by insulation excepting at the front where said insulation projects beyond the extremity of the sockets, and a plug, substantially as and for the purposes set forth.

4. The combination, with the dynamo-machines and their connections arranged on a switchboard, of lamps and their connections crossing said machine connections and groups of terminals projecting from the switchboard and inclosed by perforated blocks of insulating material, the said terminals extending but part way through the blocks, substantially as set forth.

5. In combination with the dynamo-machines and negative and positive wires, the lamps and negative and positive wires, the switchboard having terminals projecting from the front of the board and having shanks projecting from the rear of said board, link-like connections connecting the dynamo-machine terminals, link-like lamp connections crossing the dynamo-machine connections and joining the lamp-terminals, and a plug or plugs having arms to engage the terminals, substantially as and for the purposes set forth.

In testimony that I claim the foregoing I have hereunto set my hand this 17th day of April, 1891.

JOHN B. MAYER.

Witnesses:

CHARLES H. PELL,
OSCAR A. MICHEL.