

Feb. 24, 1953

J. L. GRUPEN ET AL

2,629,815

SEALED HEADLIGHT HAVING AUXILIARY REFLECTOR

Filed Feb. 12, 1947

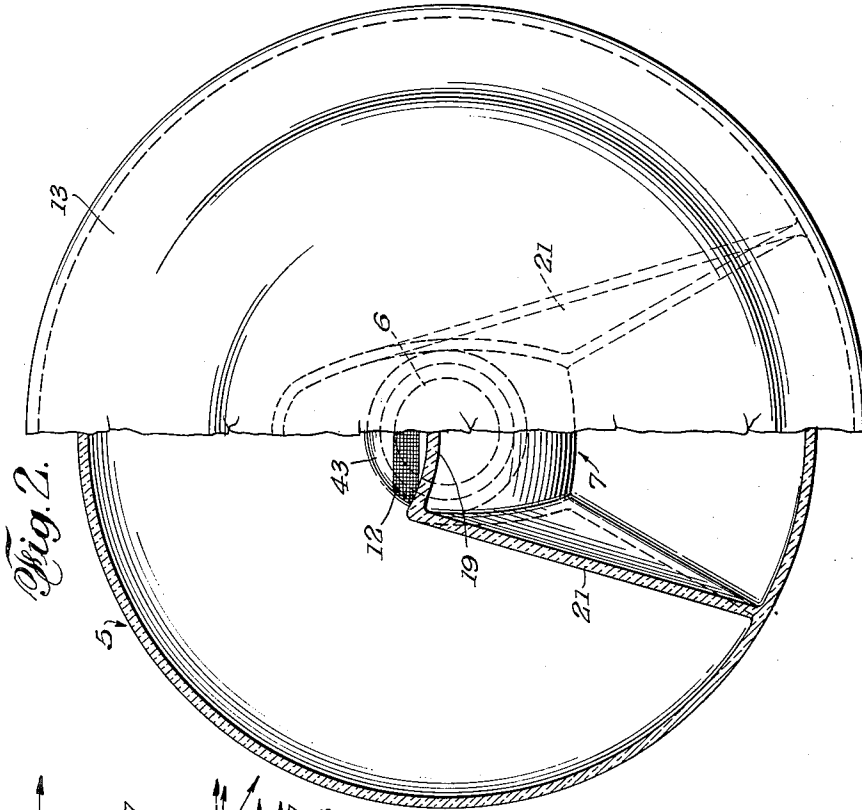

Fig. 2.

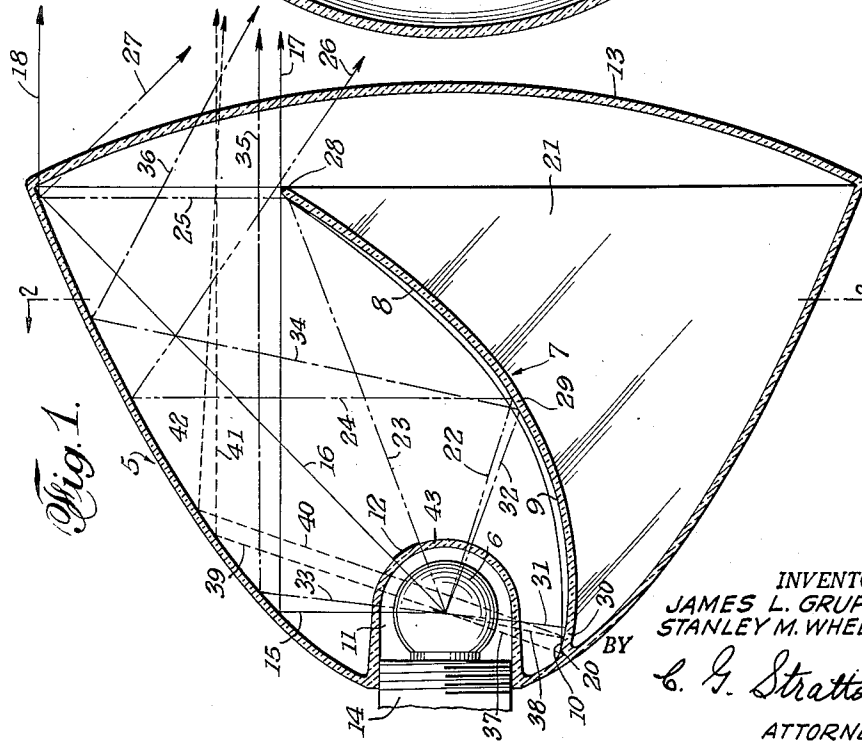

Fig. 1.

INVENTORS  
JAMES L. GRUPEN  
STANLEY M. WHEELER

BY  
*C. G. Stratton*  
ATTORNEY

# UNITED STATES PATENT OFFICE

2,629,815

## SEALED HEADLIGHT HAVING AUXILIARY REFLECTOR

James L. Grupen, San Gabriel, and Stanley M. Wheeler, San Bernardino, Calif.

Application February 12, 1947, Serial No. 728,000

12 Claims. (Cl. 240—41.35)

1

This invention relates to lamps and more particularly to headlights for automobiles, locomotives, etc., and lamps for signaling and for other purposes where a non-glaring light is desired.

The primary object of the invention is to provide a lamp, as indicated, in which light, from a light source therein, is so controlled that both glare is eliminated and the foot candle power of the projected light beam thereof increased.

Another object of the invention is to provide a sealed lamp having the characteristics stated which is operatively associated with a conventional lamp bulb, the latter being readily replaceable upon deterioration without affecting the sealed lamp.

Another object of the invention is to provide a lamp bulb so combined with a sealed lamp that the light reflective surfaces of the latter are not subjected to the deleterious effect of oxidation produced by the filament of said lamp bulb.

In so-called "sealed beam" headlights, the bulb comprises a non-separable part of the lamp which, therefore, has a useful life only as long as that of the bulb, and deterioration of the latter entails discard of the entire headlight. According to the present invention, the lamp is completely sealed against loss of efficiency caused by oxidation, moisture, dirt, etc., and is, therefore, long-lived, but its bulb is readily replaceable at low cost.

A further object of the invention is to provide a headlight or the like which completely intercepts the glare producing direct rays of a light source therein and which employs secondary reflector means for converting some or most of the intercepted direct rays into light intensifying beams that are directed to be non-glaring.

Our invention also has for its objects to provide such means that are positive in operation, convenient in use, easily installed in a working position and easily disconnected therefrom, economical of manufacture, relatively simple, and of general superiority and serviceability.

The invention also comprises novel details of construction and novel combinations and arrangements of parts, which will more fully appear in the course of the following description. However, the drawings merely show and the following description merely describes one embodiment of the present invention, which is given by way of illustration or example only.

In the drawings, like reference characters designate similar parts in the several views.

Fig. 1 is a vertical sectional view of a light projecting lamp embodying features of the invention.

2

Fig. 2 is a front view in half-section as on the line 2—2 of Fig. 1.

The basic principles of the invention involve a primary parabolic reflector 5, a light source 6 located at the focal point of said reflector, secondary reflector means 7 comprising a series of reflector components 8, 9 and 10 located within the primary reflector and so positioned that the reflector components intercept direct rays from the light source and transmit the same to the primary reflector for reflection thereby as converging downwardly directed light beam having different converging points, a transparent socket or pocket 11 which houses the light source 6, and a mask 12 on the wall of said pocket to intercept such direct rays that are not intercepted by the primary and secondary reflectors. The lamp, optionally, includes a front lens 13 through which the light rays pass.

The reflectors 5, 8, 9 and 10 may be made of suitable material such as sheet metal and provided with reflective surfaces in a convenient manner, and the pocket 11 and lens 13 are transparent and preferably of glass. According to the invention, however, the mentioned components of the lamp are preferably all formed of glass or other suitable fusible and transparent material and fused together to form a sealed integral unit in which the reflector 5 forms the peripheral walls, the pocket 11 seals the rear end, and the lens 13 seals the front end. A sealed light reflecting unit is thus provided which is readily operatively combined with the light source 6, such as a lamp bulb, by effecting a separable connection between said sealed unit and a lamp socket 14 mounting said lamp bulb.

The primary reflector 5 is of conventional parabolic form and is shown as one suitable for automotive use as a headlight. Accordingly, the reflective surface of said reflector 5 will receive the direct rays, as exemplified by solid lines 15 and 16 and reflect them through lens 13 as a non-glaring parallel beam of light indicated by the respective solid lines 17 and 18. This beam of light, however, is not completely circular but is intercepted by the secondary reflector means 7 which is positioned in front of and below the bulb 6 to intercept a segment of the rays 15 and 16 of a width commensurate to the width of reflector means 7.

As hereinbefore indicated, the reflector means 7 serves the dual purpose of intercepting direct rays from bulb 6 to prevent their egress through lens 13 and directing such intercepted rays as parallel but differently angled beams to primary reflector 5 for transmission of the latter, through

3

lens 13, as downwardly directed converging beams. Accordingly, the means 7, which is shown as comprising a series of three reflector components 8, 9 and 10, can comprise any number more than two as will be understood from the following.

Each reflector component 8, 9 and 10 is parabolic but as a series they extend from front to rear of the interior of reflector 5 as a single curved member which is also transversely curved as indicated at 19. The secondary reflector 7 closely resembles a medial longitudinal portion of a spoon bowl, is fused at its rear end at 20 to the reflector 5, and is supported by diverging walls 21 which extend from the sides of said reflector 7 downwardly to join the reflector 5. The walls 21, at the sides, secondary reflector 7, at the top, and the lower portion of primary reflector 5, at the bottom define a forwardly facing recess or pocket. The rearward end of reflector means 7 terminates at reflector 5 below the light source 6 and the forward end terminates above the light source and spaced from the uppermost portion of reflector 5. The means 7 is, therefore, disposed in front of the light source.

The reflector component 8, being parabolic, receives the direct rays of bulb 6, as exemplified by the double dot-dash lines 22 and 23, and reflects them, and all rays in between as a parallel beam, indicated by similar lines 24 and 25. Reflector 5 receives said beam and transmits the same as a converging downwardly directed beam indicated by lines 26 and 27. The points 28 and 29 define the longitudinal extent of reflector component 8. The point 28, the forward terminus of reflector 7, is above light source 6, said reflector, thereby, being in front of said light source.

The reflector component 9, defined longitudinally by points 29 and 30, is also parabolic and receives the direct rays of bulb 6, as indicated by the dot-dash lines 31 and 32, and reflects them, and all rays in between, as a parallel beam, indicated by similar lines 33 and 34. Reflector 5 receives said beam and transmits the same as a downwardly directed converging beam indicated by lines 35 and 36.

The reflector component 10, defined longitudinally by points 30 and 20 and also parabolic, receives the direct rays of bulb 6, as indicated by dotted lines 37 and 38, and reflects them, and all rays in between, as a parallel beam, indicated by similar lines 39 and 40. Reflector 5 receives said beam and transmits the same as a converging downwardly directed beam indicated by lines 41 and 42.

The focal point of each reflector component 8, 9 and 10 is that of the reflector 5—the center or filament of lamp bulb 6. It will be noted that none of the rays projected from the lamp have an upward direction because the reflector components are so positioned with relation to reflector 5 that the rays range from a horizontal direction downwardly.

The wall 43 of pocket 11 is domed and is provided with the opaque mask or the like 12, to intercept the rays between rays 16 and 23. These rays would otherwise pass directly out of the lamp to cause glare.

The invention has been described with respect to a headlight and it will be evident that suitable rearrangement of the elements may be effected for specific uses to obtain light beams of desired characteristics.

4

While we have illustrated and described what we now regard as the preferred embodiment of our invention, the construction is, of course, subject to modifications without departing from the spirit and scope of our invention. We, therefore, do not wish to restrict ourselves to the particular form of construction illustrated and described, but desire to avail ourselves of all modifications that may fall within the scope of the appended claims.

Having thus described our invention, what we claim and desire to secure by Letters Patent is:

1. A primary parabolic reflector having a circular cross section, a light source at the focal point thereof to project a reflected beam of parallel rays, and a series of secondary parabolic reflector elements positioned within the primary reflector below and spaced from the uppermost portion thereof and in front of the light source, each secondary reflector element having the light source as its focal point and arranged as a continuous reflector substantially longitudinally co-extensive with the primary parabolic reflector to receive light from said light source and to reflect the same toward said primary parabolic reflector for projection thereby outwardly and downwardly, said continuous secondary reflector starting at a point below the light source and terminating at a point above the same.

2. A primary parabolic reflector having a circular cross-section, a light source at the focal point thereof to project a reflected beam of parallel rays, a series of secondary parabolic reflector elements positioned within the primary reflector below and spaced from the uppermost portion thereof and in front of the light source, each secondary reflector element having the light source as its focal point and arranged as a continuous reflector substantially longitudinally co-extensive with the primary parabolic reflector to receive light from said light source and to reflect the same toward said primary parabolic reflector for projection thereby outwardly and downwardly, said continuous secondary reflector starting at a point below the light source and terminating at a point above the same, and an opaque light intercepting mask in the path of such rays from the light source that do not strike both the primary and secondary reflectors.

3. A light reflecting lamp comprising a primary parabolic reflector and secondary parabolic reflectors all having a common focal point, and a light source at said focal point, said primary reflector receiving direct rays from the light source and projecting them as a parallel light beam and said secondary reflectors receiving direct rays from the light source, transmitting them as parallel beams to the primary reflector and the latter projecting them as converging downwardly directed light beams, the primary reflector and the secondary reflectors being disposed on opposite sides of the light source with the latter below the former and said secondary reflectors extending upwardly in front of the light source and terminating at a point above the same.

4. A light reflecting lamp comprising a primary parabolic reflector and secondary parabolic reflectors all having a common focal point, a light source at said focal point, said primary reflector receiving direct rays from the light source and projecting them as a parallel light beam and said secondary reflectors receiving direct rays from the light source, transmitting them as parallel beams to the primary reflector

5

and the latter projecting them as converging downwardly directed light beams, the primary reflector and the secondary reflectors being disposed on opposite sides of the light source with the latter below the former and said secondary reflectors extending upwardly in front of the light source and terminating at a point above the same, and an opaque light intercepting mask in the path of such rays from the light source that do not strike both the primary and secondary reflectors.

5. A sealed light beam reflecting unit comprising a primary parabolic reflector, a transparent hollow-walled pocket adapted to house a light source located at the focal point of said primary reflector and closing the rear of the latter, a series of segmental and secondary reflector elements each having the light source as its focal point and arranged to receive outwardly and downwardly directed rays of said light source and to reflect them toward the primary reflector, said primary reflector and series of reflector elements being disposed on opposite sides of the light source with the latter below the former and said series of reflector elements, from a point below the light source, extending forwardly upward and terminating at a point above the light source, and a light transmitting lens closing the front of the primary reflector.

6. A sealed light beam reflecting unit comprising a primary parabolic reflector having a circular cross section, a transparent hollow-walled pocket adapted to house a light source located at the focal point of said primary reflector and closing the rear of the latter, a series of segmental and secondary reflector elements each having the light source as its focal point and arranged to receive outwardly and downwardly directed rays of said light source and to reflect them toward the primary reflector, an opaque mask on the hollow-walled pocket in the path of such direct rays of the light source that do not strike both the primary and secondary reflectors, and a light transmitting lens closing the front of the primary reflector.

7. In combination, a light source, a transparent hollow housing pocket for the light source, a primary parabolic reflector integrally connected to the pocket at the rear thereof, said pocket forming a rear closure for the primary reflector and said light source being located at the focal point of the reflector, a lens integrally connected to and closing the front of the reflector, and secondary reflector means within the primary reflector and comprising a series of parabolic reflector segments receiving light rays from the light source and transmitting them to the primary reflector, said secondary reflector means, from a point below the pocket, extending forwardly upward in front of said pocket and terminating above the same.

8. In combination, a light source, a transparent hollow housing pocket for the light source, a primary parabolic reflector integrally connected to the pocket at the rear thereof, said pocket forming a rear closure for the primary reflector and said light source being located at the focal point of the reflector, a segmental and opaque light intercepting mask carried by the housing pocket above the horizontal center thereof, a lens integrally connected to and closing the front of the reflector, and secondary reflector means

6

within the primary reflector and comprising a series of parabolic reflector segments receiving light rays from the light source and transmitting them to the primary reflector.

9. The combination with a primary parabolic circular reflector having a light source at its focal point, of secondary segmental reflector means within the circular reflector and comprising a series of parabolic reflectors each having its focal point at the light source and transmitting rays therefrom to the primary reflector, said primary and secondary reflectors being substantially co-extensive from front to back, and spaced connecting walls extending between the lower portion of the primary reflector and the secondary reflector means to form a forwardly facing recess.

10. In combination, a light source, a primary parabolic reflector above and at the sides of said light source and focused on the light source, a secondary reflector below and in front of the light source and comprising a series of parabolic reflector elements each having its focus on the light source, and a mask for rays from the light source that do not strike any of the above reflectors.

11. In combination, a light source, a primary parabolic reflector above and at the sides of said light source and focused on the light source, a secondary reflector below and in front of the light source and comprising a series of parabolic reflector elements each having its focus on the light source, the forward end of the secondary reflector being above said light source, and a mask for rays from the light source that do not strike any of the above reflectors.

12. A primary parabolic reflector having a circular cross-section, a light source at the focal point thereof to project a reflected beam of parallel rays, and a series of secondary parabolic reflector elements positioned within the primary reflector and in front of the light source, each secondary reflector element having the light source as its focal point and arranged as a continuous forwardly and upwardly directed reflector embodying a portion that extends at least from a point directly opposite the light source to a point above said light source, said latter portion of the secondary reflector receiving light from the light source and reflecting the same toward the primary reflector for projection by the latter outwardly and downwardly.

JAMES L. GRUPEN.  
STANLEY M. WHEELER.

#### REFERENCES CITED

The following references are of record in the file of this patent:

#### UNITED STATES PATENTS

Number	Name	Date
1,197,383	Meneely	Sept. 5, 1916
1,199,138	Wiederholdt	Sept. 26, 1916
1,462,036	Graham	July 17, 1923
1,525,234	Graham	Feb. 3, 1925
1,578,079	Davis	Mar. 23, 1926
1,657,410	Porter	Jan. 24, 1928
2,318,311	Hicks	May 4, 1943

#### FOREIGN PATENTS

Number	Country	Date
691,341	France	Oct. 20, 1930