

(19) World Intellectual Property Organization  
International Bureau



(43) International Publication Date  
4 December 2003 (04.12.2003)

PCT

(10) International Publication Number  
**WO 03/099106 A2**

(51) International Patent Classification<sup>7</sup>: **A61B**

(21) International Application Number: PCT/US03/16517

(22) International Filing Date: 23 May 2003 (23.05.2003)

(25) Filing Language: English

(26) Publication Language: English

(30) Priority Data:  
60/383,348 24 May 2002 (24.05.2002) US

(71) Applicant: **MEDICINELODGE, INC.** [US/US]; 180 South 600 West, Logan, UT 84321 (US).

(71) Applicants and

(72) Inventors: **JUSTIN, Daniel, F.** [US/US]; 185 North Winding Way, Logan, UT 84321 (US). **GOBLE, E., Marlowe** [US/US]; 5 West Blair Road., Alta, WY 83452 (US).

(74) Agents: **DELLENBACH, David, B.** et al.; Workman, Nydegger & Seeley, 1000 Eagle Gate Tower, 60 East South Temple, Salt Lake City, UT 84111 (US).

(81) Designated States (*national*): AE, AG, AL, AM, AT, AU, AZ, BA, BB, BG, BR, BY, BZ, CA, CH, CN, CO, CR, CU, CZ, DE, DK, DM, DZ, EC, EE, ES, FI, GB, GD, GE, GH, GM, HR, HU, ID, IL, IN, IS, JP, KE, KG, KP, KR, KZ, LC, LK, LR, LS, LT, LU, LV, MA, MD, MG, MK, MN, MW, MX, MZ, NO, NZ, OM, PH, PL, PT, RO, RU, SC, SD, SE, SG, SK, SL, TJ, TM, TN, TR, TT, TZ, UA, UG, UZ, VC, VN, YU, ZA, ZM, ZW.

(84) Designated States (*regional*): ARIPO patent (GH, GM, KE, LS, MW, MZ, SD, SL, SZ, TZ, UG, ZM, ZW), Eurasian patent (AM, AZ, BY, KG, KZ, MD, RU, TJ, TM), European patent (AT, BE, BG, CH, CY, CZ, DE, DK, EE, ES, FI, FR, GB, GR, HU, IE, IT, LU, MC, NL, PT, RO, SE, SI, SK, TR), OAPI patent (BF, BJ, CF, CG, CI, CM, GA, GN, GQ, GW, ML, MR, NE, SN, TD, TG).

**Published:**

— *without international search report and to be republished upon receipt of that report*

*For two-letter codes and other abbreviations, refer to the "Guidance Notes on Codes and Abbreviations" appearing at the beginning of each regular issue of the PCT Gazette.*



**WO 03/099106 A2**

(54) Title: MODULAR FEMORAL COMPONENTS FOR KNEE ARTHROPLASTY

(57) Abstract: A femoral knee prosthesis system for resurfacing a resected articular surface at the distal end of a femur includes a femoral component adapted to mate with the resected articular surface; and an attachment member. The interior surface of the femoral components configured to connect to the first attachment member when the femoral component is mated on the resected articular surface of the femur and when the first attachment member is passed through the medial side or the lateral side of the resected articular surface. The femoral component is available in one-piece systems. Mating femoral components (e.g., tapered or with lips that interlock with grooves) are also disclosed.

## MODULAR FEMORAL COMPONENTS FOR KNEE ARTHROPLASTY

5

### BACKGROUND OF THE INVENTION

#### 1. The Field of the Invention

The present invention relates to femoral components for use in total knee arthroplasty.

10

#### 2. Background Technology

During a typical knee arthroplasty procedure, the femur is resected with surgical instruments in order to form a resected femoral portion, also known as a resected femur. A femoral component typically in the form of a metal cap is then placed onto the resected femur. The femoral component is typically designed to interact with and articulate against a tibial component that is mounted onto the resected tibia.

During the arthroplasty procedure, the femoral component is inserted through an incision onto the resected femur. The larger and bulkier the femoral component is, the larger the incision is required to be, thus increasing the recovery time of the patient, thus increasing the pain associated with the surgery and the recovery time.

20 Depicted in Figures 1 and 2 is one embodiment of a prosthetic femoral component 10 having an interior surface 12 and an exterior surface 14. Interior surface 12 is comprised of a plurality of intersecting substantially flat surfaces that correspond to discrete cut surfaces on a femur. Pegs 16a-b project from interior surface 12 for engaging with the femur. Pegs 16a-b are designed to be implanted within the resected femur, thereby anchoring the femoral component to the femur. The exterior surface 14 articulates against the tibial component.

30 However, the pegs are affixed using a compression fit into the resected femur and project from the interior surface, thereby adding to the bulkiness and size of the femoral component, thereby requiring a larger incision during surgery.

What is therefore needed is a femoral component for use in a knee arthroplasty procedure that is not bulky and does not require a large incision during surgery. What is also needed is a femoral component that is firmly affixed to the resected femur and is convenient to mount thereon.

35

### BRIEF DESCRIPTION OF THE DRAWINGS

Various embodiments of the present invention will now be discussed with reference to the appended drawings. It is appreciated that these drawings depict only

typical embodiments of the invention and are therefore not to be considered limiting of its scope.

Figure 1 is a front perspective view of a prior art femoral component;

Figure 2 is a back perspective view of the prior art femoral component shown  
5 in Figure 1;

Figure 3 is a back perspective view of a femoral component of the present invention featuring at least one threaded bore formed on the interior surface thereof that is configured to receive an attachment member extended through the resected femur; an optional second threaded bore and attachment member are shown in  
10 phantom lines; the attachment member may be extended through the medial and/or lateral side;

Figure 4 is a back perspective view of another femoral component of the present invention featuring at least one engaging, receiving pocket filled with a receiving, engaging material that receives and engages at least one attachment  
15 member extended through the resected femur; an optional additional receiving surface and attachment member(s) are shown in phantom lines;

Figure 5 is a perspective view of the femoral component of Figure 3 being mounted on a resected femur; a receiving surface 66 for an optional plate 29 of the femoral component is shown in phantom lines;

Figure 6 is a perspective view of the femoral component of Figures 3 and 5  
20 shown as being mounted on the resected femur of Figure 5 and having an attachment member (shown primarily in phantom lines) extended through the resected femur and into the femoral component, thereby securing the femoral component to the femur;

Figure 7 is a side cross sectional view of an alternative embodiment of a  
25 femoral component having inwardly projecting lips shown as being mounted within corresponding grooves cut into a resected femur, thereby securing the femoral component to the resected femur;

Figure 8 is a perspective view of a femoral component having a tapered interior surface that is being mounted onto a resected femur having a complimentary,  
30 tapered, mating surface, thereby securing the femoral component to the resected femur;

Figure 8a is a cross sectional view of an alternative femoral component, having a non-chamfered, curved surface, shown as mounted onto a resected femur, demonstrating that a femoral component having inwardly projecting lips can have a  
35 variety of different interior surfaces.

Figure 9 is a perspective view of an alternative embodiment of a two-piece femoral component divided lateral to medial;

Figure 10 is a perspective view of the femoral component shown in Figure 9 in an assembled state;

5 Figure 11 is a perspective view of a two-piece femoral component having meshing teeth and divided lateral to medial;

Figure 12 is a perspective view of a two-piece femoral component divided anterior to posterior;

10 Figure 13 is a perspective view of the femoral component shown in Figure 12 in an assembled state;

Figure 14 is a perspective view of a femoral component divided anterior to posterior and having meshing teeth;

Figures 15A-16B demonstrate assembled and exploded views of another two-piece femoral component of the present invention.

15 **DETAILED DESCRIPTION OF THE PREFERRED EMBODIMENTS**

Figures 3-6 depict examples of femoral knee prosthesis systems used in knee arthroplasty wherein the femoral components are readily slid in from the medial or lateral side through an incision and onto a femoral resection 60 (Fig. 5). An attachment member, such as a bolt or screw can then be inserted through the femur until contacting the femoral component. The procedure is minimally invasive and does not require as large an incision as components having the pegs 16a-b of Figures 1 and 2. The bolt, screw or other attachment member securely affixes the femoral component to the resected femur, rather than merely relying upon a compression fit.

25 Figures 7-8A depict examples of femoral components 70, 80 used in knee arthroplasty wherein a mating relationship, e.g., mating lips 78a-b and grooves 79a-b (Fig. 7) or mating tapering surfaces (Figs. 8) maintain the femoral component on the resected femur.

Figures 9-14 depict connectible two-piece end use femoral components 102, 131, 161, and 191 used in knee arthroplasty wherein the two parts are readily, 30 independently slid in from the medial or lateral side through an incision and then connected and mounted onto a femoral resection. Optionally, one part may be mounted on the femoral resection followed by another part being connected thereto. Both parts may also be first mounted, then connected together. An attachment member, such as a bolt or screw can then be inserted through the femur until

contacting the femoral component. Optionally, bone cement can be employed to cement the femoral component to the resected femur.

A coupling member, e.g., a bolt or a screw attaches one part of the femoral component to another. The procedure is minimally invasive and does not require as large an incision as one piece components because one part of the femoral component may be placed through the incision, followed the other part of the femoral component. The individual pieces of the femoral component themselves may also be employed without the corresponding mating piece, such as when only a portion (e.g., a tibial portion) of the component is needed for a particular procedure.

Figures 15A-16B depict a connectible two-piece end use femoral component used in knee arthroplasty wherein the two parts are readily, independently slid in from the medial or lateral side through an incision and then connected and mounted onto a femoral resection. Optionally, one part may be mounted on the femoral resection followed by another part being connected thereto. Integral protrusions extending from one part attach the one part of the femoral component to the other. The procedure is minimally invasive and does not require as large an incision as one piece components because one part of the femoral component may be placed through the incision, followed the other part of the femoral component. Pegs are employed for anchoring the component on a femoral resection.

Each of these femoral components will now be discussed in greater detail beginning with reference to Figures 3, 5 and 6. Figure 3 is a back perspective view of a femoral knee prosthesis system for resurfacing a resected articular surface 64 (Fig. 5) at the distal end 62 of a femur 60. As shown in Figure 5, the resected articular surface 64 of the distal end 62 of the femur 60 has a medial side 61 and an opposing lateral side 63.

Prosthesis system 20 of Figure 3 comprises: (i) a U-shaped femoral component 22 having (i) an interior surface 26 adapted to mate with the resected articular surface 64 and (ii) an opposing articulating surface 24; (ii) a first attachment member, e.g., elongated bolt 36 having a threaded end; and (iii) a threaded bore 32 formed on interior surface 26 of femoral component 22.

Threaded bore 32 is an example of means formed on the interior surface 26 of the femoral component 22 for connecting the first attachment member 36 to the femoral component 22 when the femoral component 22 is mated on the resected articular surface 64 of the femur 60 and when the first attachment member 36 is passed through the medial side or the lateral side of the resected articular surface 64.

Threaded bore 32 is angled such that when femoral component 22 is mated on the resected articular surface of femur 60, bolt 36 can be passed through medial side 61 or lateral side 63 of the resected articular surface 64 so as to threadedly engage with the threaded bore 32 (see Figs. 5-6).

5 Femoral component 22 comprises a substantially U-shaped medial condyle 28 connected to a substantially U-shaped lateral condyle 30. Femoral component has an anterior end 35 and a posterior end 37. The medial condyle 28 is connected to the lateral condyle 30 such that an elongated slot 39 is formed between the lateral condyle and the medial condyle. However, in another embodiment, the femoral component of  
10 the present invention comprises merely a substantially U-shaped lateral condyle or a substantially U-shaped medial condyle, depending upon the desired procedure.

An optional plate 29 of the femoral component 22 may be employed to provide differential surface area for engagement with a complementary surface on the prosthesis.

15 As further shown in Figure 3, system 20 comprises (i) an optional second attachment member 38; and (ii) means (e.g., second threaded bore 34) formed on the interior surface 26 of the femoral component 22 for connecting the second attachment member 38 to the femoral component 22 when the femoral component 20 is mated on the resected articular surface 64 of the femur 60 and when the second attachment  
20 member 38 is passed through the medial side or the lateral side of the resected articular surface 64.

Optionally, another attachment member may extend into the medial, anterior surface into another threaded bore adjacent bore 32, if desired.

25 Screws, bolts, pins or other forms of fasteners that can be driven through femur 60 so as to engage with interior surface 26 of femoral component 22 are each examples of attachment members of the present invention. One or more attachment members 36, 38 may attach to respective on or more bores 32, 34. In one embodiment, the attachment members are on opposing sides of the femoral component from each other, as shown in Figure 3. As mentioned, in another  
30 embodiment, the attachment members mount into the same side of the femoral component (see also Fig. 4). These attachment members can engage with interior surface 26 by having threaded bores (Fig. 3) or by positioning receiving, engaging material on interior surface 42 to which the fasteners can penetrate and engage with, as will now be discussed with reference to Figure 4.

Figure 4 is a back perspective view of another femoral knee prosthesis system 40 comprising (i) a femoral component 41 comprising an interior surface 42 adapted to mate with the resected articular surface 64 and an opposing articulating surface 43; (ii) a first attachment member, e.g., elongated screw 52 having a threaded end; and (iii) a pocket 48 formed on interior surface 42 of femoral component 41.

Femoral component 41 has at least one pocket 48 (filled with an engaging, receiving material 49) that receives at least one attachment member 52 extended through the resected femur 60; an optional additional pocket 50 and an additional corresponding attachment member 54 are shown in phantom lines. Pockets 48, 50 filled with such material are additional examples of means formed on the interior surface 42 of the femoral component 41 for connecting an attachment member to the femoral component.

Pockets 48, 50 are formed on the interior surface 26 of the femoral component 22 and are filled with an engaging, receiving material, such as an adhesive (e.g., polymethylmethacrylate) or another material that is soft enough to receive the attachment member, but can also retain the attachment member therein. Other examples of such a receiving, engaging material include pliable polymers such as Delrin or polyetheretherketone that are capable of receiving and deforming to the shape of the first attachment member.

In one embodiment, in addition to the use of a bolt or screw to attach the femoral component to the prosthesis, a bone cement can be employed to further enhance the adhesion of the femoral component to the resected femur. The bone cement can be applied before and/or during mounting of the femoral component. For example, the femoral component can be partially attached and then a syringe or other form of delivery tube used to inject bone cement between femoral component and the femur. In addition, a porous or fibrous material such as a wire mesh may be attached to the interior surface 26 of the femoral component 22 to thereby foster bone growth between the femoral component 22 and the resected femur 60 and to provide surface area for attaching the bone cement between the femoral component and the resected femur.

Figure 5 is a perspective view of the femoral component 22 of Figure 3 being mounted on a resected femur 60. A complimentary receiving surface 66 for the optional plate 29 of the femoral component is shown in phantom lines.

Figure 6 is a perspective view of the femoral component 22 of Figures 3 and 5 shown as being mounted on the resected femur 60 of Figure 5 and having an

*attachment member 36* (shown primarily in phantom lines) extended through the resected femur 60 and into the femoral component 22, thereby securing the femoral component 22 to the femur 60. This attachment tightly pulls the femoral component 22 toward and onto the femur 60.

5            Figures 5 and 6 also illustrate a method for resurfacing a femur as part of a surgical procedure, comprising (i) resecting an articulating surface 64 at a distal end 62 of a femur 60 so as to form a resected articular surface 64 extending between a medial side 61 and a later side 63; (ii) mounting a femoral component 22 having an interior surface 26 on at least a portion of the resected articular surface 64; (iii)  
10            passing a first attachment member 36 through the lateral side or the medial side of the resected articular surface 64; and (iv) connecting the first attachment member 36 to the femoral component 22 so that the first attachment member 36 secures the femoral component 22 to the resected articular surface 64.

                  In one embodiment, the act of resecting an articulating surface comprises  
15            resecting a medial condyle and a lateral condyle at the distal end of the femur. In Figure 5, the medial and lateral condyles of femur 60 have been resected. As discussed above, femoral component 22 comprises a substantially U-shaped lateral condyle connected to a substantially U-shaped medial condyle.

                  In another embodiment, the act of resecting an articulating surface 64  
20            comprises resecting only a medial condyle or only a lateral condyle at the distal end 62 of the femur 60, without the other of the medial condyle or lateral condyle being resected. In such an alternate embodiment, the act of mounting a femoral component on at least a portion of the resected articular surface 64 comprises the femoral component being a unicondular lateral condyle or medial condyle.

25            In one embodiment, the act of passing a first attachment member 36 through the lateral side or the medial side of the resected articular surface 64 comprises: (i) boring a hole through the femur; and (ii) advancing the first attachment member 36 through the hole. The hole can be bored through the femur at an oblique angle  $\alpha$ , as reflected in Figures 3 and 6. The hole can be bored by making an incision in the skin  
30            adjacent the the femur, properly orienting a tubular alignment guide, then boring the hole with a drill through the alignment guide. Optionally, however, the first attachment member is advanced through the femur at such an angle  $\alpha$  (e.g., by being advanced through a tubular alignment guide used to orient the first attachment member) without initially boring a hole therethrough. In one embodiment the angle  $\alpha$   
35            is in the range of approximately 15 to approximately 45 degrees, e.g., about 30



degrees, but may be a variety of different angles which achieve the result of affixing the femoral component to the femur.

The method of resurfacing the femur may further comprise (i) passing a second attachment member 38 (Fig. 3) through the lateral side or the medial side of the resected articular surface; and (ii) connecting the second attachment member 38 to the femoral component 22 so that the second attachment member 38 secures the femoral component 22 to the resected articular surface.

As discussed above, Figures 7-8A depict examples of femoral components 70, 80 wherein a mating relationship between the femoral component and the resected femur maintains the femoral component on the resected femur. The prosthetic femoral component can come in a variety of alternative configurations.

Figure 7 is a side cross sectional view of femoral component 70, which comprises a "U" shaped main body 71 having an interior surface 73 an exterior surface 75, an anterior end 77a, and a posterior end 77b, and anterior and posterior inwardly projecting lips 78a, 78b, respectively, extending from an interior surface 73 of the main body 71. As shown, lips 78a-b are mounted within corresponding grooves 79a, 79b cut into a resected femur 74, thereby securing the femoral component 70 to the resected portion 72 of the femur 74. In one embodiment, main body 71 has the same or substantially the same configuration as the femoral component 22 shown in Figures 3, 5 and 6, but has lips 78a-b projecting inwardly from the interior surface 73 of respective posterior and anterior ends 77a-b thereof. Groove 79a is formed in an anterior surface 72a of the femur, while groove 79b is formed in a posterior surface 72b of the femur.

The lips 78a-b may project inwardly from one or more condyles. For example, one posterior lip 78b may extend from a medial condyle while another posterior lip 78b extends from a lateral condyle. Optionally, posterior lips 78b may extend from the lateral and the medial condyle. Figure 7 is representative of a posterior lip 78b extending from the interior surface of the lateral and/or medial condyle.

Similarly, the anterior lip 78a may extend from the interior surface 73 of the anterior end 77a of the lateral or medial condyle, or may extend as a single lip from the interior surface of both the anterior end of the medial condyle and the anterior end of the lateral condyle.

Thus, in one embodiment, femoral component 70 comprises (i) a lateral condyle (e.g., similar to condyle 30 of Fig. 3) having a substantially U-shaped

configuration and having an interior surface 76 and an opposing exterior surface 77, each extending between an anterior end 73 and an opposing posterior end 75; and (ii) a medial condyle (e.g., similar to condyle 28 of Fig. 3) having a substantially U-shaped configuration and having an interior surface 76 and an opposing exterior surface 77 each extending between an anterior end 73 and an opposing posterior end 75, the medial condyle being connected to the lateral condyle such that an elongated slot is formed between the lateral condyle and the medial condyle.

A first engagement lip 78a projects from the interior surface 71 of at least the lateral condyle or the medial condyle at the anterior end 77a thereof; and a second engagement lip 78b projects from the interior surface of at least the lateral condyle or medial condyle at the posterior end 77b thereof

Mating lips 78a-b and grooves are an example of a mating relationship between the femoral component 70 and the resected femur 74 that maintains the femoral component 70 on the resected femur 74. Other examples of such a mating relationship include an embodiment in which a single mating lip extends from a U-shaped main body into a single groove on a resected femur.

Thus, femoral component 70 comprises a main body 71 having an interior surface 73 and an opposing articulating surface 75 each extending between a lateral side and a medial side, the interior surface 73 having a substantially U-shaped transverse cross section; and at least one and preferably first and second lips 78a-b projecting inwardly from the anterior or posterior end of the interior surface 73 of the body 76.

Cuts are formed on resected femoral surface 72 complementary to interior surface 71 with respective complimentary mating grooves 79a-b being formed to receive respective lips 78a-b. In this configuration, femoral component 76 can be laterally slid onto femur 74 so that lips 78a-b are received within the corresponding grooves 79a-b on femur 74, thereby securing femoral component 70 to femur 74.

Another method for resurfacing a femur thus comprises: (i) resecting an articulating surface at a distal end of a femur 74 so as to form a resected articular surface 72 having an anterior surface and a posterior surface each extending between a lateral side and a medial side, at least one of the anterior surface and posterior surface having a groove 79a-b therein; and (ii) sliding a femoral component 70 onto the resected articular surface 72, a lip 78a-b of the femoral component 70 mating with

the groove 79a-b, the femoral component 70 being slid medial to lateral or lateral to medial.

As shown in Figure 7, the step of resecting an articulating surface preferably comprises forming first and second opposing grooves 79a-b in the resected articular surface 72 and wherein first and second lips 78a-b of the femoral component 70 are  
5 slid into respective grooves 79a-b, the first and second lips 78a-b being slid medial to lateral or lateral to medial.

Figure 8 shows a tapered relationship between a femoral component 80 and a resected femur 90, which is an other example of a mating relationship between a  
10 femoral component 80 and a resected femur 90 that maintains the femoral component 80 on a tapered resected surface 88 of a resected femur 90.

Figure 8 is a perspective view of a femoral component 80 having an exterior surface 82 and a tapered interior surface 84 that is being mounted in the direction of arrow 89 onto a resected femur 90 having a complimentary, tapered, mating resected  
15 surface 88, thereby securing the femoral component 80 to the resected femur 90.

More specifically, component 80 comprises a body 82 having an interior surface 84 and an opposing articulating surface 82, each extending between a lateral side 81 and a medial side 83. The interior surface 84 has a substantially U-shaped transverse cross section that inwardly tapers. The taper may occur from the medial  
20 side to the lateral side or from the lateral side to the medial side.

In the embodiment of Figure 8, U-shaped femoral component 80 is formed wherein the U-shaped cavity bounded by the femoral component constricts, i.e., decreases in size, medial to lateral. (In another embodiment, the femoral component decreases in size lateral to medial and the interior surface 84 is configured with a  
25 mating surface). Femur 90 is cut in a mating configuration such that the femoral component 80 wedges onto femur 90 as the femoral component 80 is slid in the direction of arrow 89 onto femur 90 lateral to medial, thereby retaining the femoral component on femur 90.

As reflected in Figure 8, a method for resurfacing a femur 90 comprises: (i)  
30 resecting an articulating surface at a distal end of a femur 90 so as to form a resected articular surface 88 having an anterior surface 92 and a posterior surface 94 each extending between a lateral side 96 and a medial side 98, at least one of the anterior surface 92 and posterior surface 94 being sloped relative to the other such that the anterior surface 92 and posterior surface converge toward the lateral side 96 or medial

side 98; and (ii) sliding a femoral component 80 onto the resected articular surface 88, the femoral component being 80 slid lateral to medial as shown or medial to lateral.

Figure 8a is a cross sectional view of an alternative femoral component 80a, having an articulating surface 82a and a non-chamfered, curved interior surface 84a, shown as mounted onto a resected femur 86a. Anterior and posterior lips 88a-b mate with corresponding grooves 89a-b in femur 86a. Figures 7 and 8A demonstrates that a femoral component having inwardly projecting lips 88a-b can have a variety of different interior surfaces. The interior surface 84a of the femoral component of Figure 8A can also be tapered similarly to Figure 7 so as to mate with a complimentary tapered resected femur, as discussed with reference to Figure 7.

As another feature of the present invention, Figures 9-14 depict connectible two-piece end use femoral components 102, 131, 161, and 191 used in knee arthroplasty wherein the two parts are readily, independently slid in from the medial or lateral side through an incision and then connected and mounted onto a femoral resection. Optionally, one part may be mounted on the femoral resection followed by another part being connected thereto. An attachment member, such as a bolt or screw can then be inserted through the femur until contacting the femoral component. A coupling member, e.g., a bolt or a screw attaches one part of the femoral component to another. The procedure is minimally invasive and does not require as large an incision as one piece components because one part of the femoral component may be placed through the incision, followed the other part of the femoral component.

Figure 9 is a perspective view of a two-piece end use femoral component 102 divided lateral to medial, while Figure 10 is a perspective view of the femoral component 102 shown in an assembled state. Femoral component 102 is configured for "end use" in that it is configured to be permanently mounted onto a resected articular surface during a resurfacing procedure so as to articulate against a tibia and/or prosthetic tibial component and is designed for actual daily use by a patient who has experienced the procedure in order to replace at least a portion of a knee.

Figure 9 thus depicts a femoral knee prosthesis system 100 for resurfacing a resected articular surface at the distal end of a femur, comprising: end use femoral component 102 having (A) an interior surface 105 adapted to mate with the resected articular surface and (B) an opposing articulating surface 107.

The end use femoral component further comprises (i) a first portion, i.e., patellar condyle 103, comprising a first section of the articulating surface; (ii) a

second portion, i.e., tibial condyle 104 comprising a second section of the articulating surface, the second portion 104 being selectively mateable with the first portion 103; and (iii) bolts 106, 108 configured to selectively connect the first portion 103 to the second portion 105. Bolts 106, 108 are examples of means for selectively  
5 connecting the first portion to the second portion. Bolt 124 secures the femoral component 103 to the femur. However, a variety of other methods may be employed to secure the femoral component to the femur, such as the use of bone cement or pegs compressed into the resected femur. In one embodiment, at least a portion of patellar condyle 103 corresponds to an anterior portion of the resected femur while at least a  
10 portion of tibial condyle 104 corresponds to a posterior portion of the resected femur.

As shown, bolts 106, 108 extend through respective apertures 110a-b, 112a-b, 114a-b, 116a-b along orientation lines 118a-b to connect portions 103, 105 such that the combined condyle portions 103, 105 collectively form the femoral component 102 shown in Figure 10.

15 U-shaped Femoral component 102 is divided along a joint 119 so that femoral component 102 comprises an anterior section 103 and a posterior section 105. At least one and preferably first and second passageways defined by apertures 110a-b, 112a-b, 114a-b, and 116a-b extend laterally through both anterior section 103 and posterior section 105 such that when sections 103 and 105 are aligned, threaded bolts  
20 106, 108 can be laterally threaded into the passageways so as to secure the mating sections.

During a resurfacing procedure, the first and second portions 103, 105 are readily, independently slid in from the medial or lateral side through an incision and then connected and mounted onto a femoral resection. Optionally, one part 103 or  
25 105 may be mounted on the femoral resection followed by the mating part being connected thereto and mounted on the femoral resection.

A method for resurfacing a femur employing femoral component 102 thus comprises (i) resecting an articulating surface at a distal end of a femur so as to form a resected articular surface; (ii) positioning a first portion 103 of an end use femoral  
30 component on or adjacent to the resected articular surface, the first portion 103 comprising a first section of an articulating surface of the end use femoral component 102; (iii) positioning a second portion 104 of the end use femoral component 102 on or adjacent to the resected articular surface, the second portion comprising a second section of the articulating surface of the end use femoral component 102; (iv) securing  
35 the first portion 103 of the end use femoral component 102 to the second portion of

the end use femoral component; and (v) attaching the end use femoral component 102 to the resected articular surface, e.g., through the use of bolt 124, a screw, pin or other means for attaching.

Figure 11 is a perspective view of a system 130 comprising a substantially similar femoral component 131 having meshing teeth 136, 138 and divided lateral to medial. Component 131 comprises (i) a first portion, i.e., patella condyle 132, comprising a first section of the articulating surface; (ii) a second portion, i.e., tibial condyle 134 comprising a second section of the articulating surface, the second portion 134 being selectively mateable with the first portion 132; and (iii) bolts 142, 144 configured to selectively connect the first portion 132 to the second portion 134 by extending through respective apertures 146, 148 and additional apertures not shown. Bolts 142, 144 are examples of means for selectively connecting the first portion to the second portion. Bolt 150 is an example of means for securing the femoral component 103 to the femur.

As opposed to the smooth joint 119 of Figure 8, femoral component 131 can be formed with a joint 140 having complementary mating teeth 136, 138.

In yet another embodiment, as discussed with respect to Figures 12 and 13, the first portion comprises a substantially U-shaped medial condyle (162) and the second portion comprises a substantially U-shaped lateral condyle (164).

Figure 12 is a perspective view of a femoral component 161 of system 160 divided anterior to posterior and Figure 13 is a perspective view of the femoral component 161 shown in Figure 12 in an assembled state.

Femoral component 161 comprises: (i) a lateral condyle 162 having a substantially U-shaped configuration and having a lateral side 163 and an opposing medial side 166 each extending between an anterior end 165 and an opposing posterior end 167; (ii) a medial condyle 164 having a substantially U-shaped configuration and having a lateral side 168 and an opposing medial side 169 each extending between an anterior end 171 and an opposing posterior end 173. The lateral side 168 of the medial condyle 164 is configured to mate with the medial side 166 of the lateral condyle 162 such that a slot 179 is formed between the medial condyle and the lateral condyle at the posterior ends thereof.

Bolts 170, 172 are examples of means for connecting the medial condyle to the lateral condyle when the medial condyle and lateral condyle are mated. Bolt 178 secures the femoral component 161 to the femur. However, a variety of other

methods may be employed to secure the femoral component to the femur, such as the use of bone cement or pegs compressed into the resected femur.

Femoral component 161 is centrally divided anterior to posterior along a linear joint 180 so that femoral component 161 comprises a medial section and a lateral section. At least one and preferably first and second passageways defined by apertures 174a-b and 176a-b extend laterally through both medial section and lateral section such that when sections are aligned, bolts 170, 172 can be laterally threaded into respective passageways so as to secure the sections together.

Figure 14 is a perspective view of a femoral component divided anterior to posterior and having meshing teeth. Figure 14 shows a system 190 comprising a substantially similar femoral component 191 having meshing teeth 202, 204 and divided anterior to posterior. Component 191 comprises (i) a first portion, i.e., lateral condyle 192, comprising a first section of the articulating surface; (ii) a second portion, i.e., medial condyle 194 comprising a second section of the articulating surface, the second portion being selectively mateable with the first portion; and (iii) bolts 196, 198 configured to selectively connect the first portion to the second portion. Bolts 196, 198 are examples of means for selectively connecting the first portion to the second portion. Bolt 206 or other method of attachment can be employed to secure the femoral component 191 to the femur.

As depicted in Figure 14, in contrast to having a linear joint, femoral component 191 can be formed with a joint having complementary mating teeth formed on each of the sections.

Figures 15A-D demonstrate assembled and exploded views of another two-piece femoral component of the present invention employing protrusions in order to link the pieces of the component. The two parts are readily, independently slid in from the medial or lateral side through an incision and then connected and mounted onto a femoral resection. Optionally, one part may be mounted on the femoral resection followed by another part being connected thereto and mounted on the femoral resection.

Figure 15 depicts a femoral knee prosthesis system 210 for resurfacing a resected articular surface at the distal end of a femur, comprising: (i) end use femoral component 211 having (i) an interior surface 215 adapted to mate with the resected articular surface and (ii) an opposing articulating surface 217.

The end use femoral component 211 comprises (i) a first portion, i.e., patellar condyle 214, comprising a first section of the articulating surface; and (ii) a second

portion, i.e., tibial condyle 212 comprising a second section of the articulating surface, the second portion 212 being selectively mateable with the first portion 214. Protrusions 224-230 extending from tibial condyle 212 are configured to be received within first portion 214, thereby mating the first and second portions.

5 Pegs 220-222 are additional examples of means for securing the femoral component 103 to the femur.

Femoral knee prosthesis system 210 further comprises bolts 240, 240a or screws that are configured to connect first portion 214 to second portion 212 once the protrusions 224-230 are mounted in first portion 212. In one embodiment, an incision

10 is made in only one side of the knee. Thus, only one of bolts 240 or 240a is employed to connect first portion 214 to second portion 212.

As shown, protrusions 224-230 extend through respective apertures 232, 238, 240 (fourth aperture not shown) and bolt 240 is extended through aperture 242 and into bored aperture 244 such that the combined condyle portions 214, 212 collectively

15 form the femoral component 210 shown in Figures 15B and 16B. The use of protrusions 224-230 and at least one bolt 240 forms a strong connection between first and second portions 212, 214. Bolt 24a is extended through aperture 242a and into a bored aperture in portion 214.

As discussed above, the femoral components of the present invention are

20 conveniently slid in from the medial or lateral side through an incision. In addition, the femoral components of the present may be conveniently slid (either as one piece or two-piece members) through an incision in between the medial and lateral sides. The femoral components are designed to articulate against the tibia and/or a prosthetic tibial component.

25 It is appreciated that the various configurations, structures, and methods as discussed above can be mixed and matched to form yet other unique configurations, structures, and methods.

Additional disclosure relating to apparatuses and methods of the present invention is available in a United States Patent application filed simultaneously

30 herewith on Friday, May 23, 2003 entitled "Femoral Components for Knee Arthroplasty" with Daniel F. Justin and E. Marlowe Goble as inventors, attorney docket no. 13447.22.2, express mail label no. EV 203 529 716 US, which application is incorporated herein in its entirety by reference.

The present invention may be embodied in other specific forms without

35 departing from its spirit or essential characteristics. The described embodiments are



to be considered in all respects only as illustrative and not restrictive. The scope of the invention is, therefore, indicated by the appended claims rather than by the foregoing description. All changes which come within the meaning and range of equivalency of the claims are to be embraced within their scope.

What is claimed is:

1. A femoral knee prosthesis system for resurfacing a resected articular surface at the distal end of a femur, the prosthesis system comprising:
  - an end use femoral component having (i) an interior surface adapted to
  - 5 mate with the resected articular surface; and (ii) an opposing articulating surface, the end use femoral component further comprising:
    - a first portion comprising a first section of the articulating surface;
    - a second portion comprising a second section of the articulating
    - 10 surface, the second portion being selectively mateable with the first portion; and
    - means for selectively connecting the first portion to the second portion.
2. A femoral knee prosthesis system as recited in claim 1, wherein the
- 15 first portion comprises a patellar condyle and the second portion comprises a tibial condyle.
3. A femoral knee prosthesis system as recited in claim 1, wherein the first portion comprises a substantially U-shaped medial condyle and the second portion comprises a substantially U-shaped lateral condyle
- 20 4. A femoral knee prosthesis system as recited in claim 1, wherein the means for selectively connecting the first portion to the second portion comprises a bolt extending between the first portion and the second portion.
5. A femoral knee prosthesis system as recited in claim 1, further comprising means for securing the femoral component to the resected articular
- 25 surface at the distal end of a femur.
6. A system as recited in claim 5 wherein the means for securing the femoral component to the resected articular surface at the distal end of a femur comprises a bolt.
7. A system as recited in claim 5, wherein the first portion is positioned
- 30 on the side of the second portion.
8. A system as recited in claim 5, wherein the first portion is mounted above the second portion.
9. A system as recited in claim 5, wherein the first portion has ridges and grooves that correspond to interlocking ridges and grooves in the second
- 35 portion.

10. A system as recited in claim 5, wherein the second portion of the femoral component comprises a protuberance configured to selectively mate with the first portion.

5 11. A system as recited in claim 10, wherein the means for selectively connecting the first portion to the second portion comprises a bolt.

12. A system as recited in claim 1, wherein a plurality of protuberances extend from the second portion and selectively mate within a respective plurality of apertures in the first portion.

10 13. A femoral knee prosthesis system for resurfacing a resected articular surface at the distal end of a femur, the prosthesis system comprising:

an end use femoral component having (i) an interior surface adapted to mate with the resected articular surface and (ii) an opposing articulating surface, the end use femoral component further comprising:

15 a first portion comprising a first section of the articulating surface; and

a second portion comprising a second section of the articulating surface, wherein the first portion is selectively connected to the second portion.

20 14. A femoral knee prosthesis system as recited in claim 13, wherein the first portion comprises a patellar condyle and the second portion comprises a tibial condyle.

25 15. A femoral knee prosthesis system as recited in claim 13, wherein the first portion comprises a substantially U-shaped medial condyle and the second portion comprises a substantially U-shaped lateral condyle.

16. A femoral knee prosthesis system as recited in claim 13, wherein the means for selectively connecting the first portion to the second portion comprises a bolt extending between the first portion and the second portion.

30 17. A method comprising:  
resecting an articulating surface at a distal end of a femur so as to form a resected articular surface;

positioning a first portion of an end use femoral component on or adjacent to the resected articular surface, the first portion comprising a first section of an articulating surface of the end use femoral component;

positioning a second portion of the end use femoral component on or adjacent to the resected articular surface, the second portion comprising a second section of the articulating surface of the end use femoral component; securing the first portion of the end use femoral component to the second portion of the end use femoral component; and attaching the end use femoral component to the resected articular surface.

18. A femoral component of a knee prosthesis for resurfacing a resected articular surface at the distal end of a femur, the femoral component comprising:

a lateral condyle having a substantially U-shaped configuration and having a lateral side and an opposing medial side each extending between an anterior end and an opposing posterior end; and

a medial condyle having a substantially U-shaped configuration and having a lateral side and an opposing medial side each extending between an anterior end and an opposing posterior end, the lateral side of the medial condyle being configured to mate with the medial side of the lateral condyle each such that a slot is formed between the medial condyle and the lateral condyle, wherein the medial condyle is selectively connected to the lateral condyle.

19. An end use femoral component of a knee prosthesis for resurfacing a resected articular surface at the distal end of a femur, the femoral component comprising:

a patellar condyle configured such that at least a portion of the patellar condyle corresponds to an anterior portion of the resected articular surface; and

a tibial condyle configured to be selectively connected to the patellar condyle, such that the collective patellar and tibial condyles collectively form an end use femoral component having (i) an interior surface adapted to mate with the resected articular surface; and (ii) an opposing articulating surface.

20. A femoral component as recited in claim 19, wherein the tibial condyle has at least one protrusion extending therefrom.

21. A femoral component as recited in claim 19, wherein the patellar condyle has at least one aperture for receiving the protrusion.

1 / 10

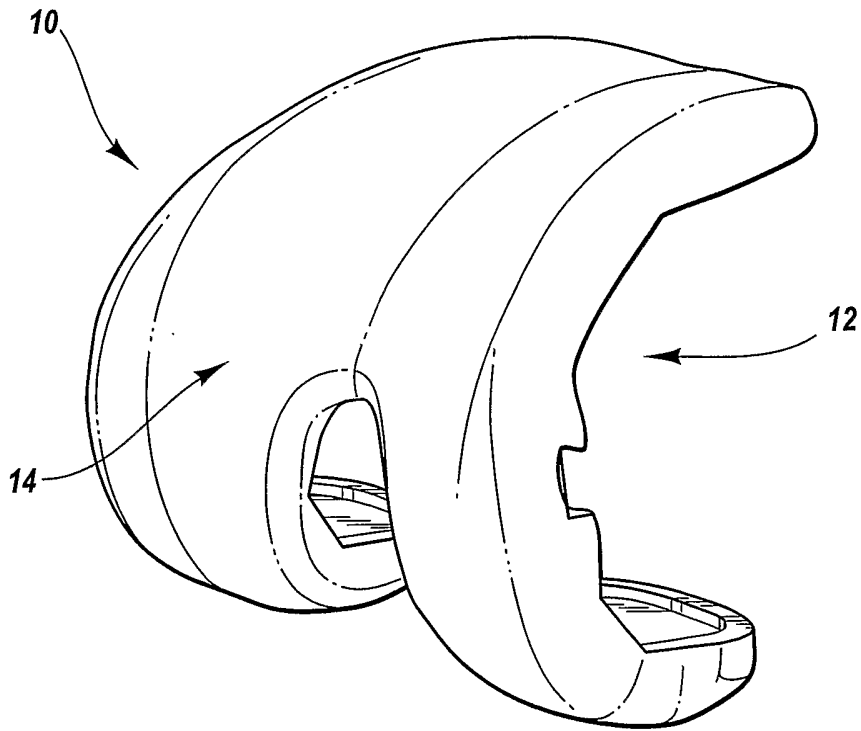

**Fig. 1**  
**(Prior Art)**

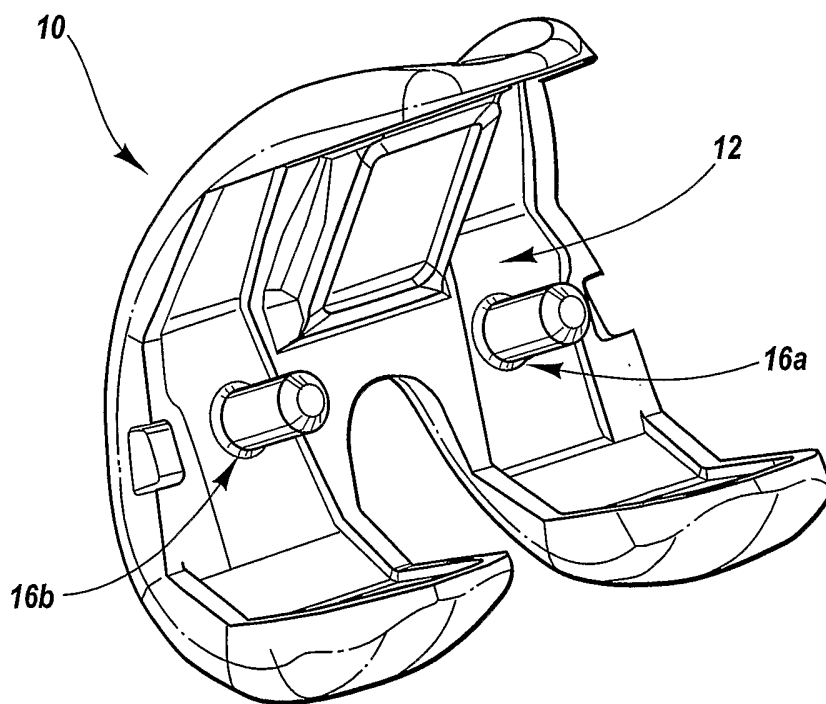

**Fig. 2**

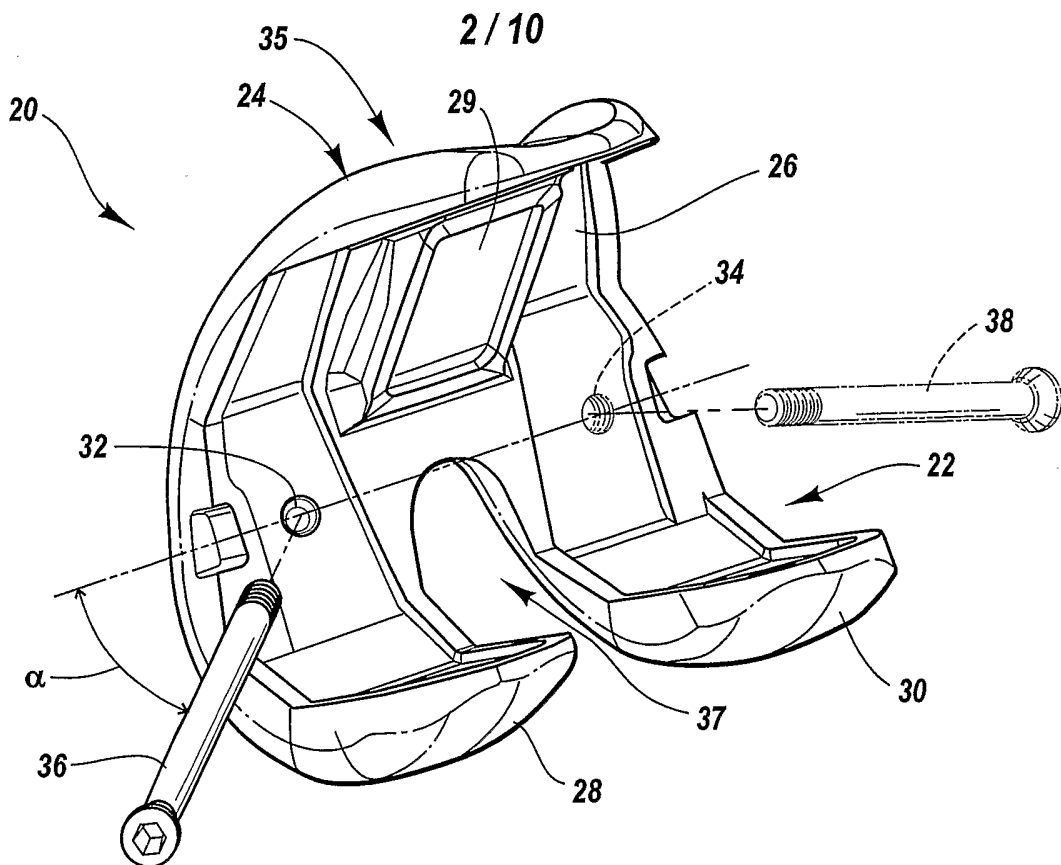

Fig. 3

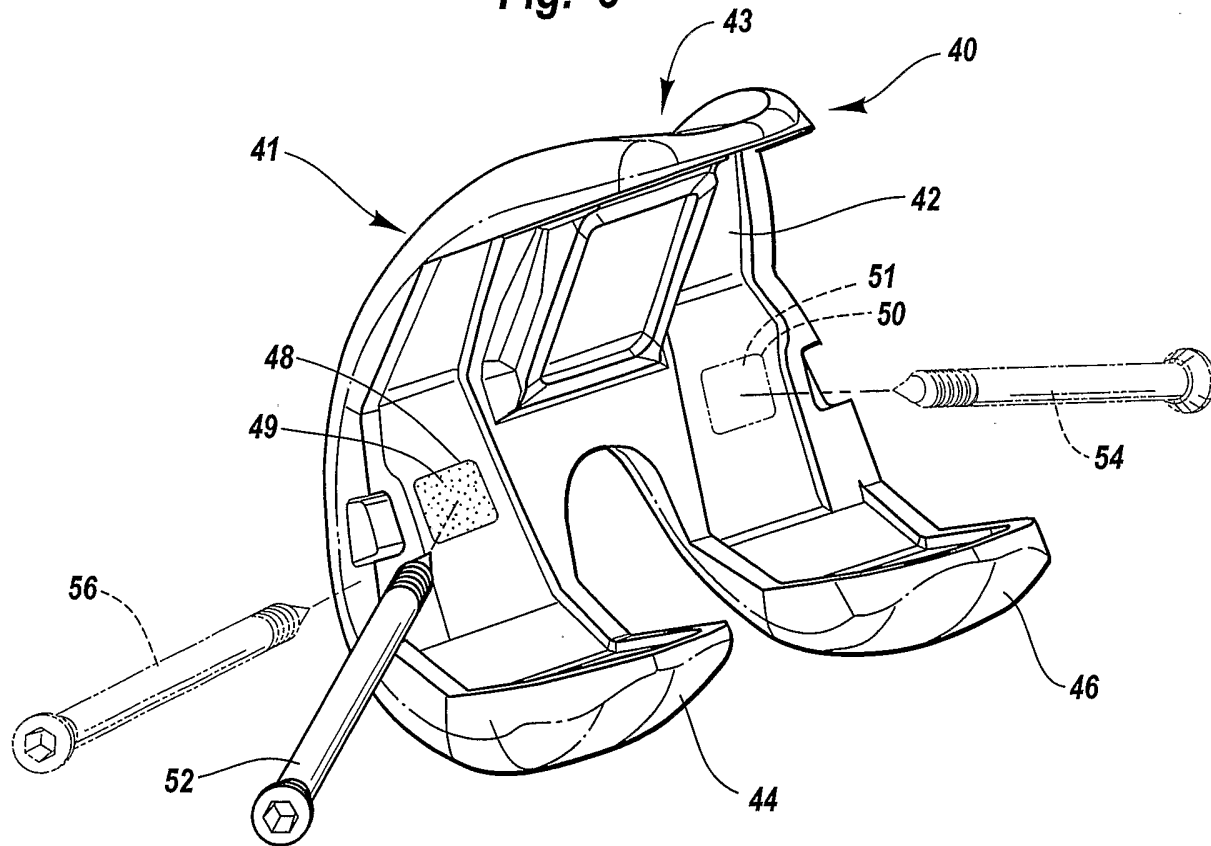

Fig. 4

3 / 10

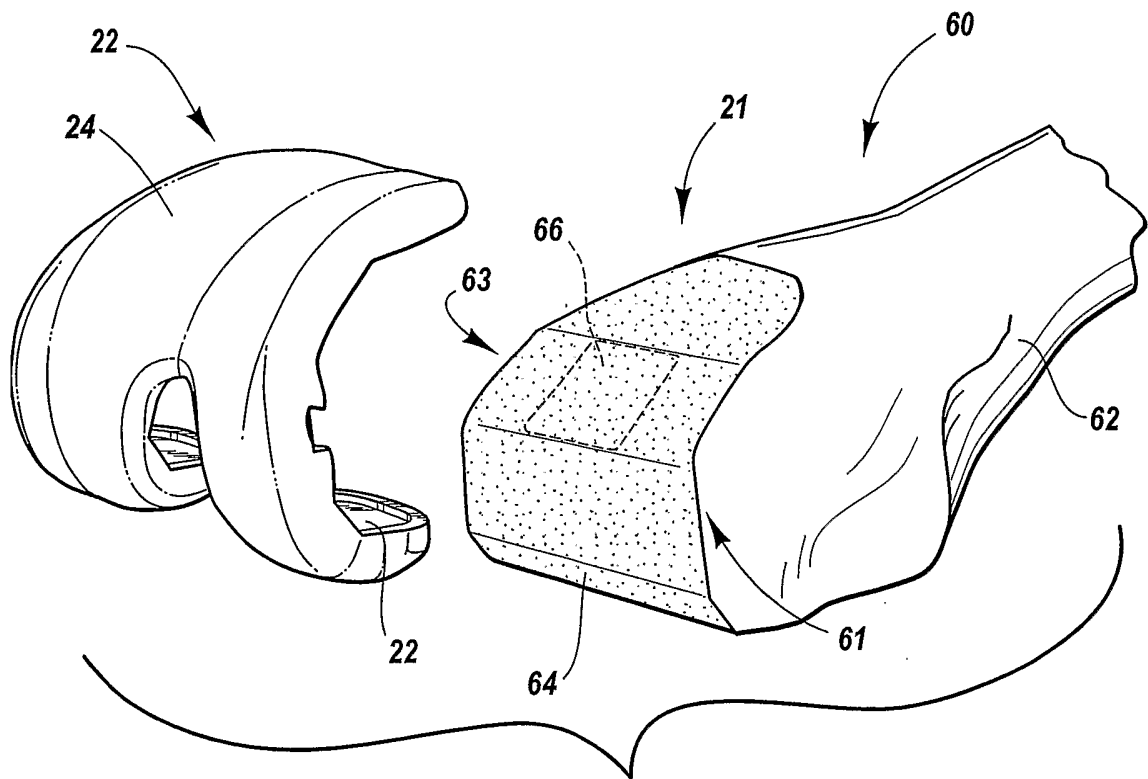

Fig. 5

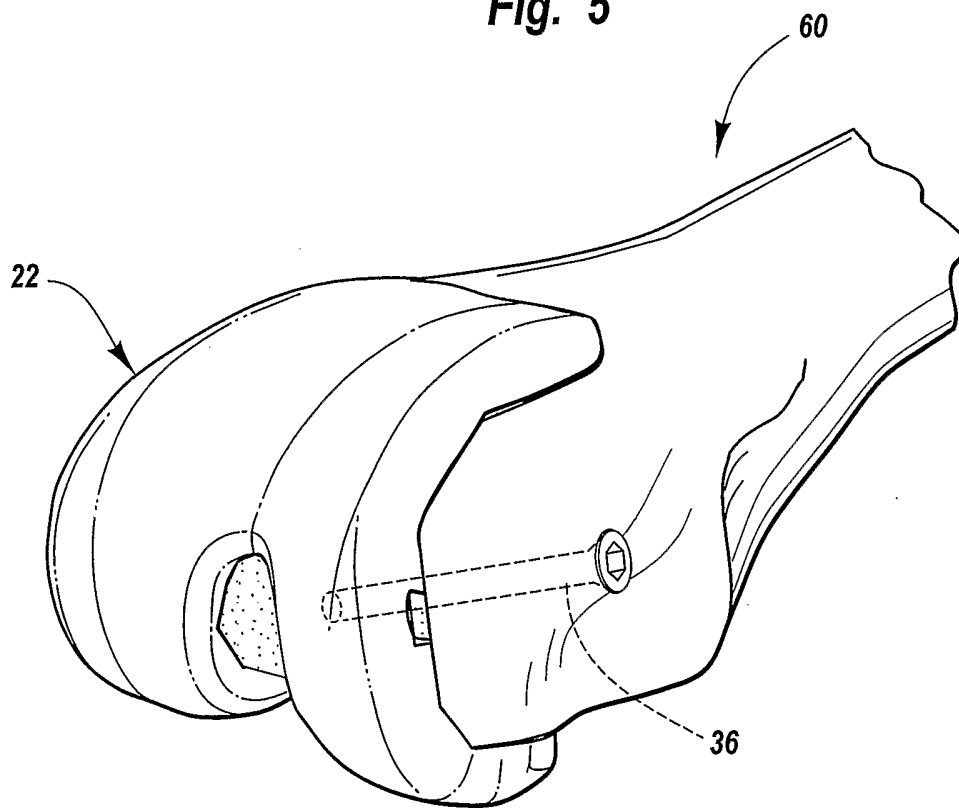
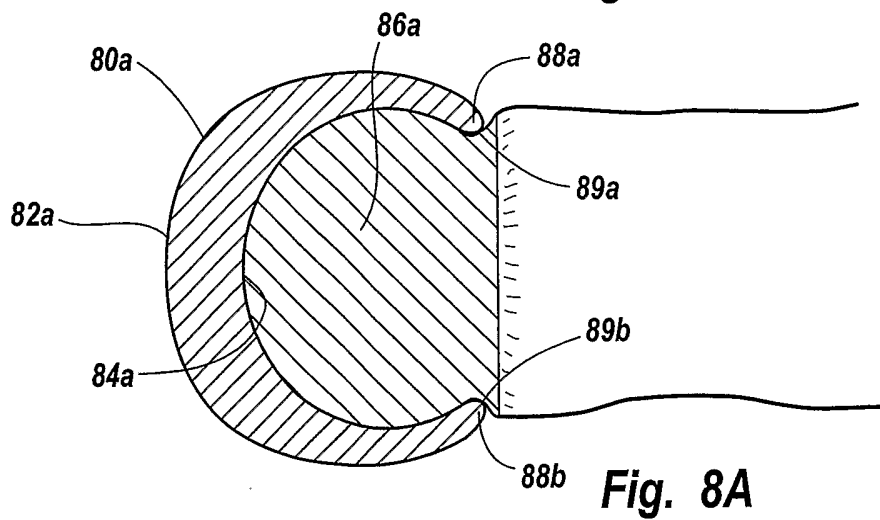
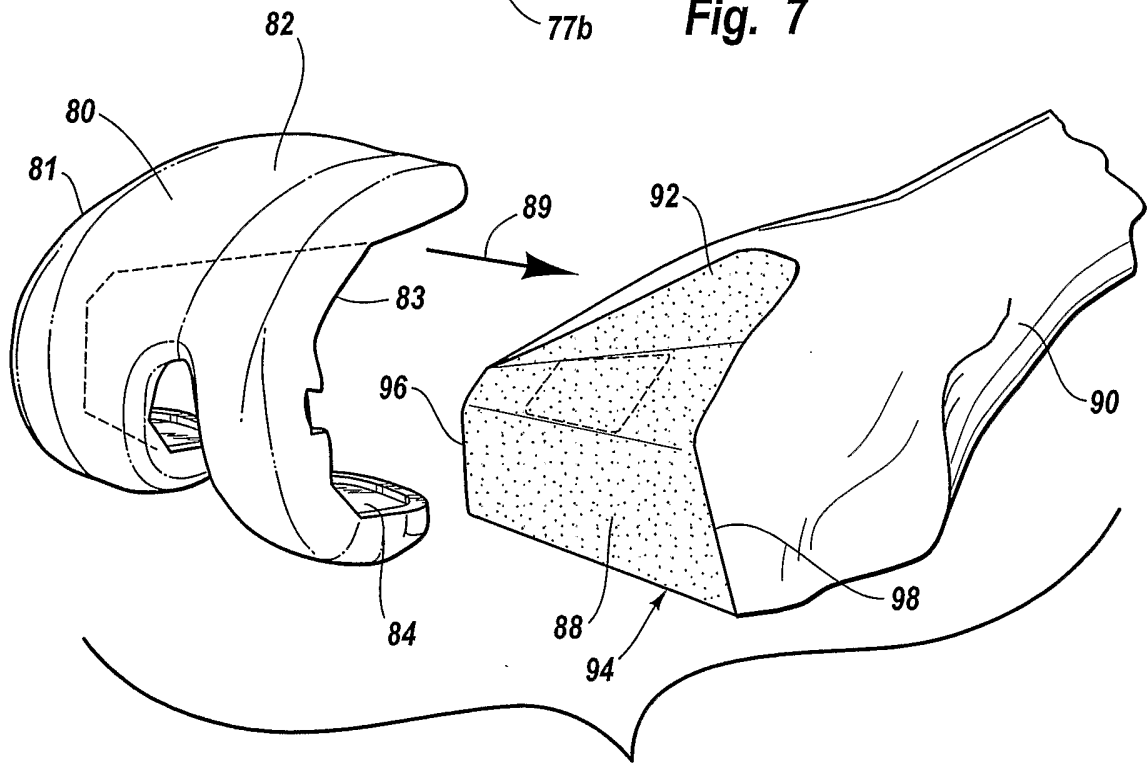
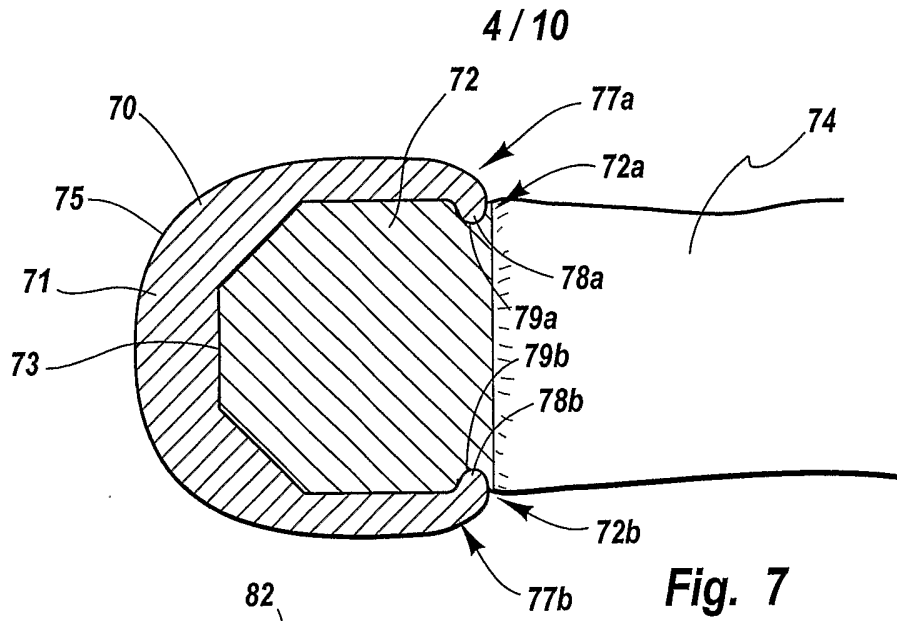

Fig. 6





5 / 10

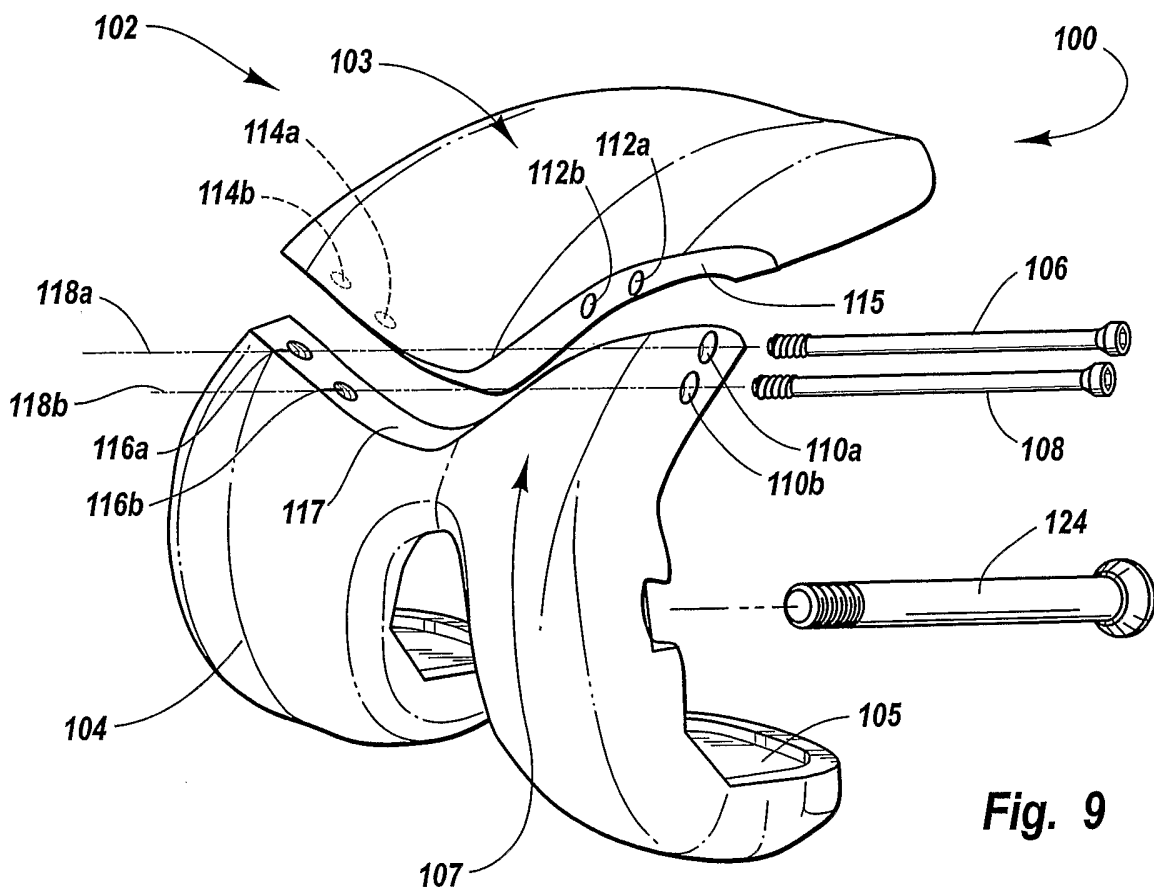

Fig. 9

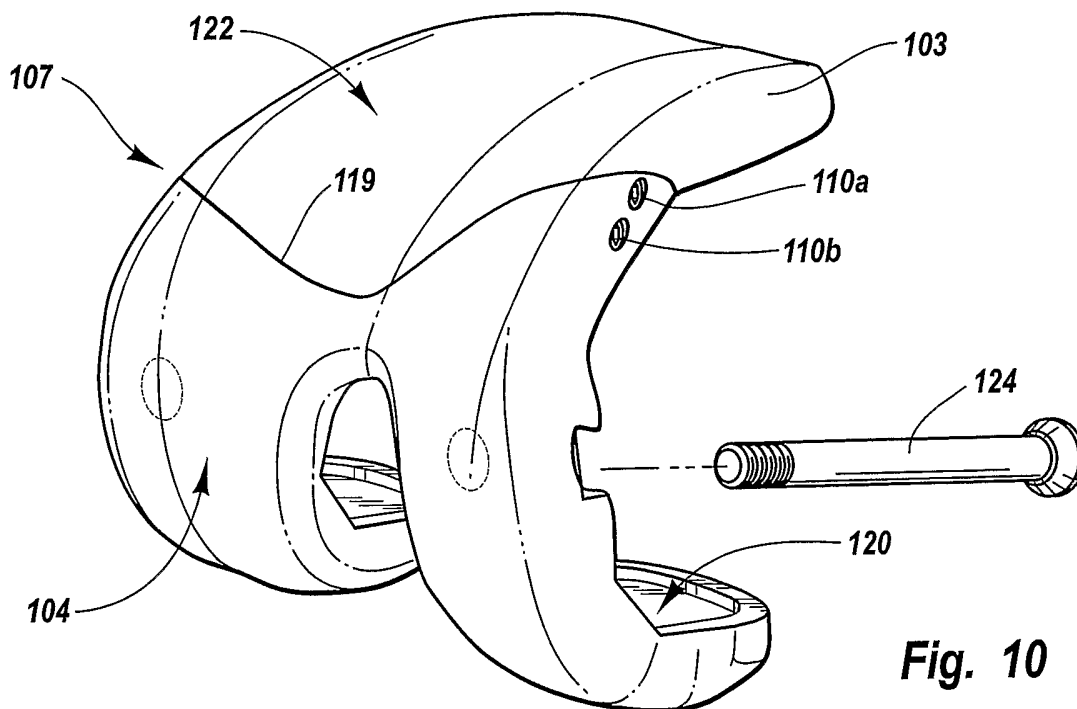

Fig. 10

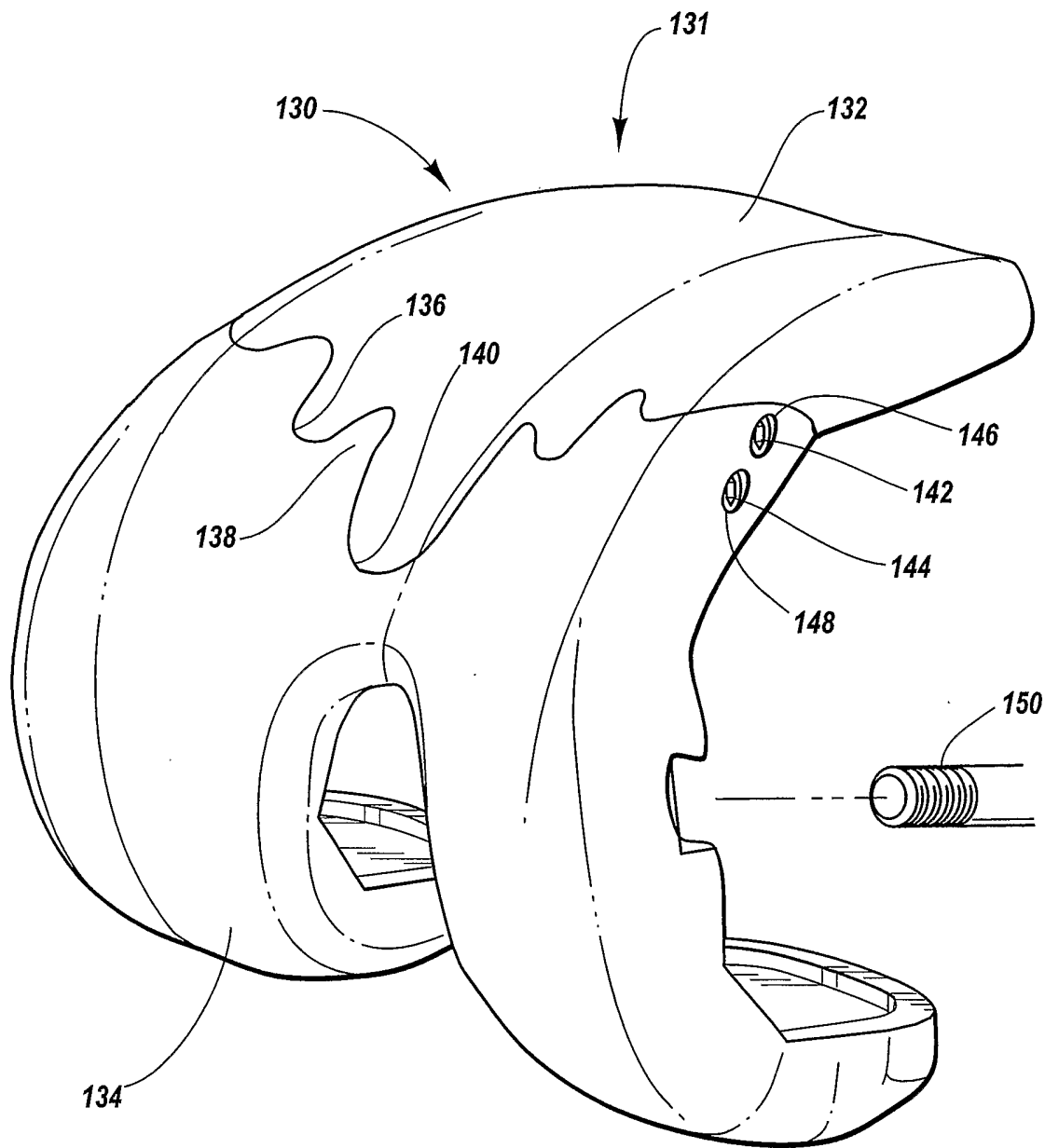
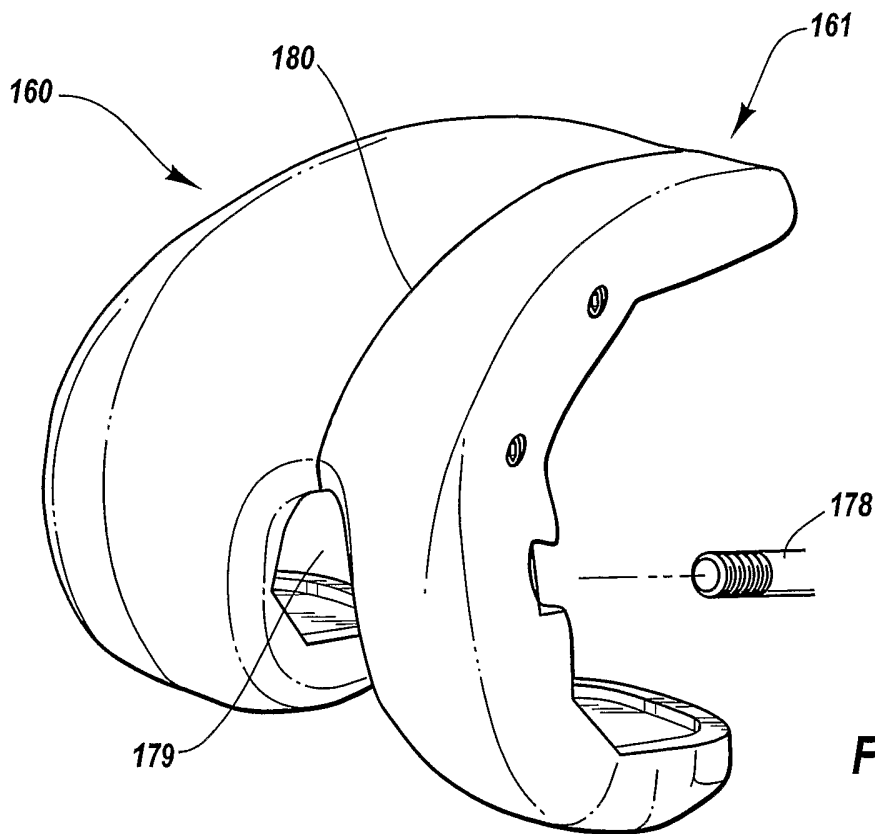
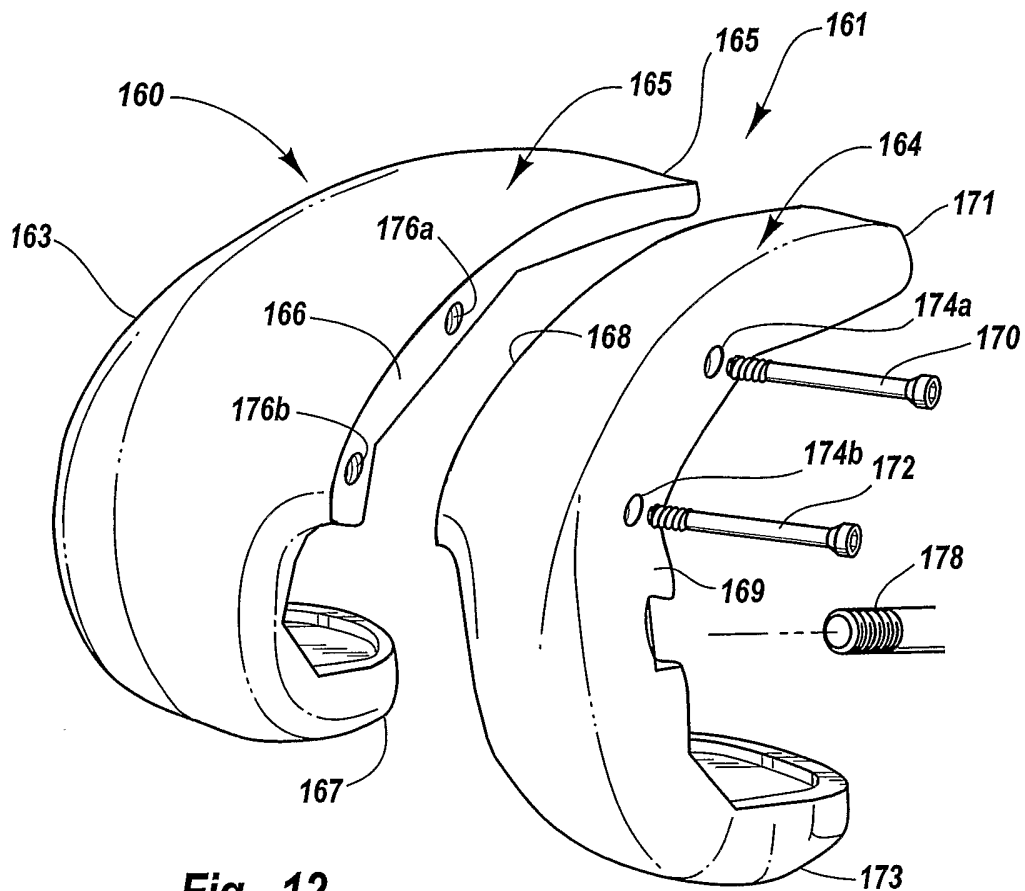

Fig. 11



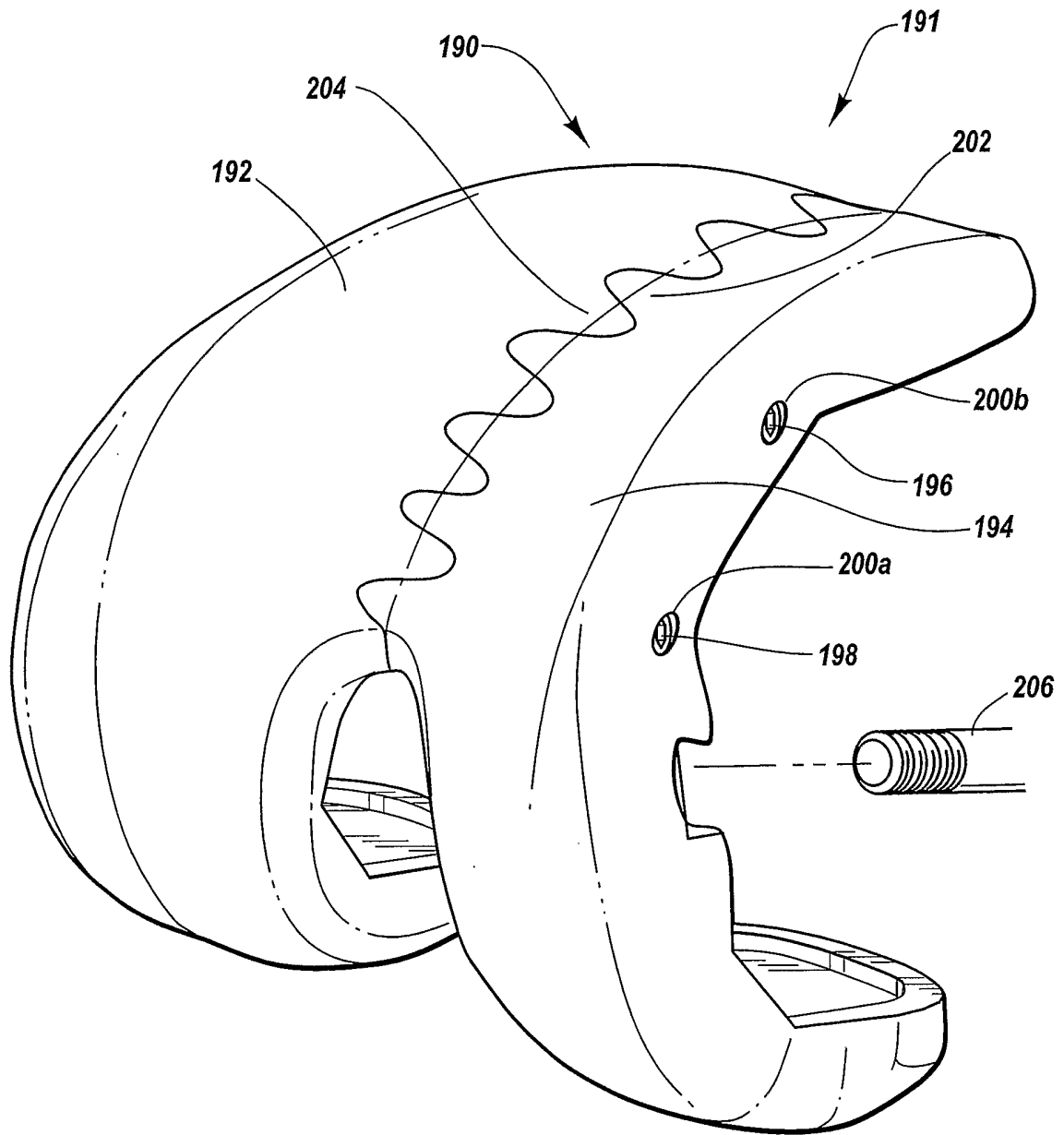
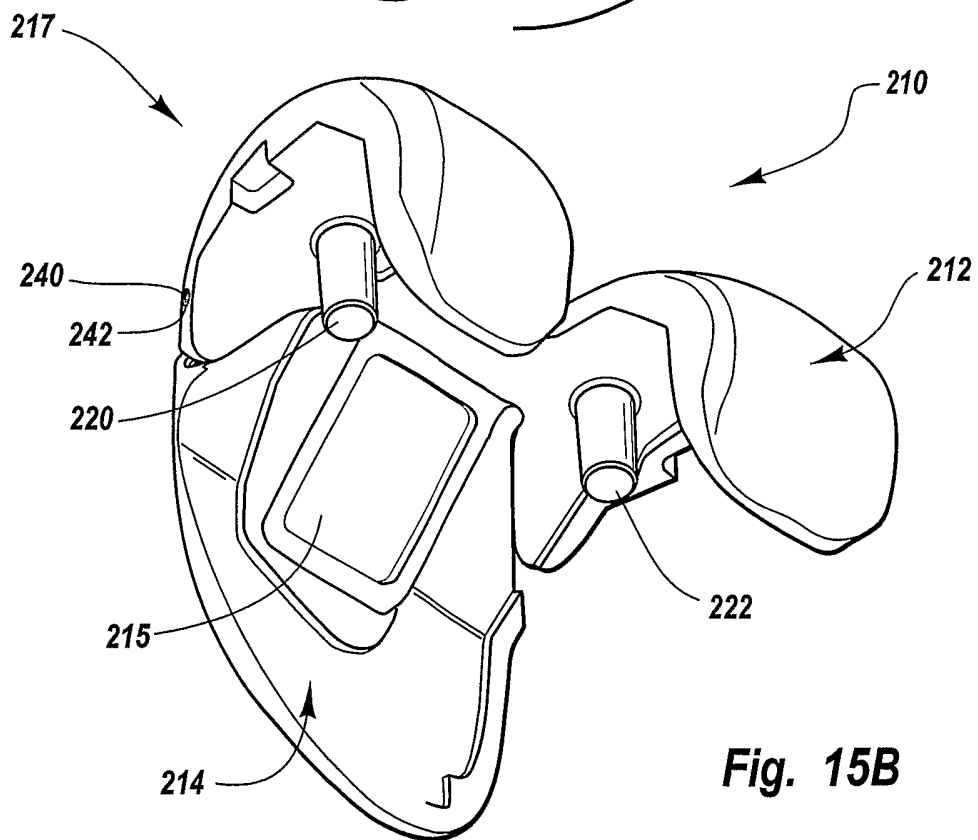
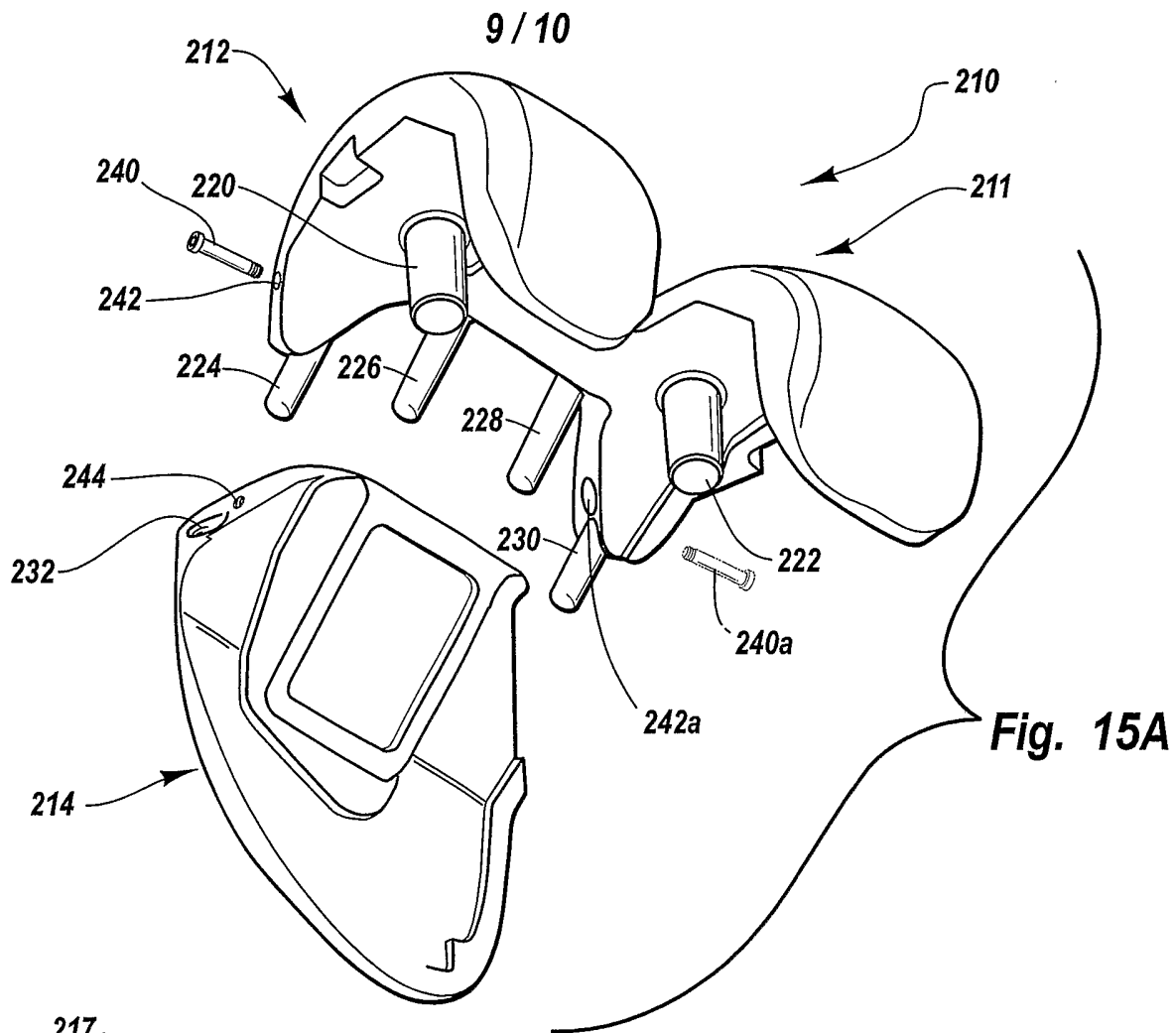

Fig. 14



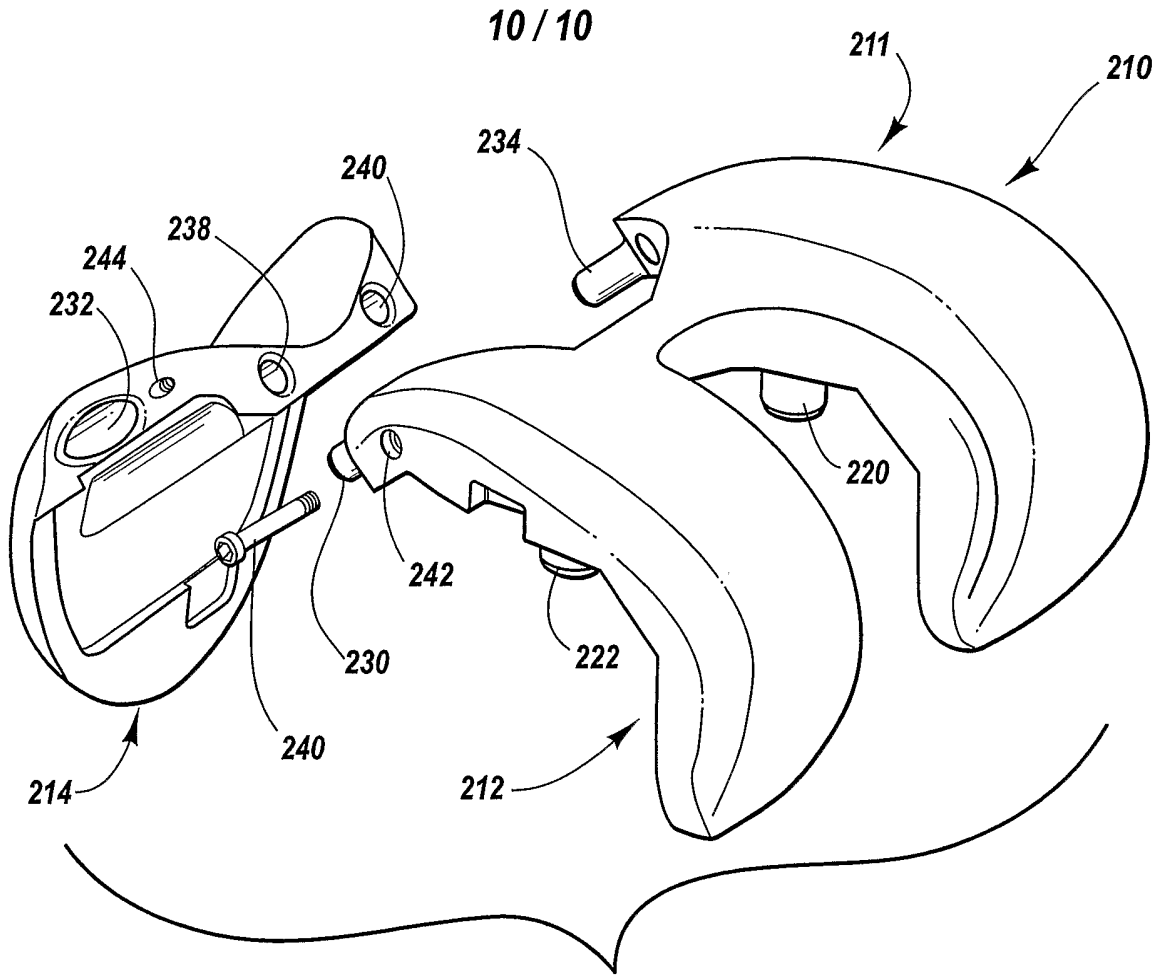

Fig. 16A

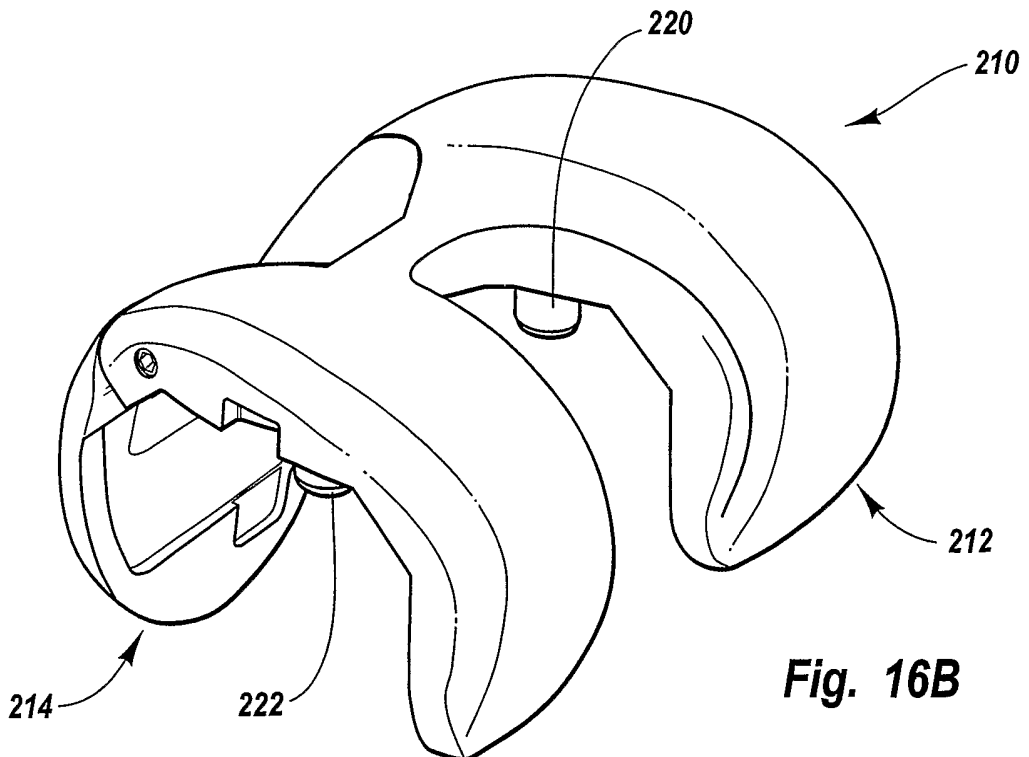

Fig. 16B