

(12) INTERNATIONAL APPLICATION PUBLISHED UNDER THE PATENT COOPERATION TREATY (PCT)

(19) World Intellectual Property Organization
International Bureau



(43) International Publication Date
1 March 2001 (01.03.2001)

PCT

(10) International Publication Number
WO 01/14792 A1

(51) International Patent Classification⁷: F21V 14/04

(21) International Application Number: PCT/US00/40760

(22) International Filing Date: 28 August 2000 (28.08.2000)

(25) Filing Language: English

(26) Publication Language: English

(30) Priority Data:
09/383,311 26 August 1999 (26.08.1999) US

(71) Applicant and

(72) Inventor: LASSOVSKY, Leon, A. [US/US]; Castillo de Utera #1, E-41013 Sevilla (ES).

(74) Agents: WATHEN, Douglas, L. et al.; Gifford, Krass, Groh, Sprinkle, Anderson & Citkowski, PC, Suite 400, 280 N. Old Woodward Avenue, Birmingham, MI 48009 (US).

(81) Designated States (national): AL, AM, AT, AU, AZ, BA, BB, BG, BR, BY, CA, CH, CN, CU, CZ, DE, DK, EE, ES,

FI, GB, GE, GH, GM, HR, HU, ID, IL, IS, JP, KE, KG, KP, KR, KZ, LC, LK, LR, LS, LT, LU, LV, MD, MG, MK, MN, MW, MX, NO, NZ, PL, PT, RO, RU, SD, SE, SG, SI, SK, SL, TJ, TM, TR, TT, UA, UG, US, UZ, VN, YU, ZW.

(84) Designated States (regional): ARIPO patent (GH, GM, KE, LS, MW, MZ, SD, SL, SZ, TZ, UG, ZW), Eurasian patent (AM, AZ, BY, KG, KZ, MD, RU, TJ, TM), European patent (AT, BE, CH, CY, DE, DK, ES, FI, FR, GB, GR, IE, IT, LU, MC, NL, PT, SE), OAPI patent (BF, BJ, CF, CG, CI, CM, GA, GN, GW, ML, MR, NE, SN, TD, TG).

Published:

- With international search report.
- Before the expiration of the time limit for amending the claims and to be republished in the event of receipt of amendments.

For two-letter codes and other abbreviations, refer to the "Guidance Notes on Codes and Abbreviations" appearing at the beginning of each regular issue of the PCT Gazette.

(54) Title: LUMINAIRE MODULE HAVNG MULTIPLE ROTATABLY ADJUSTABLE REFLECTORS

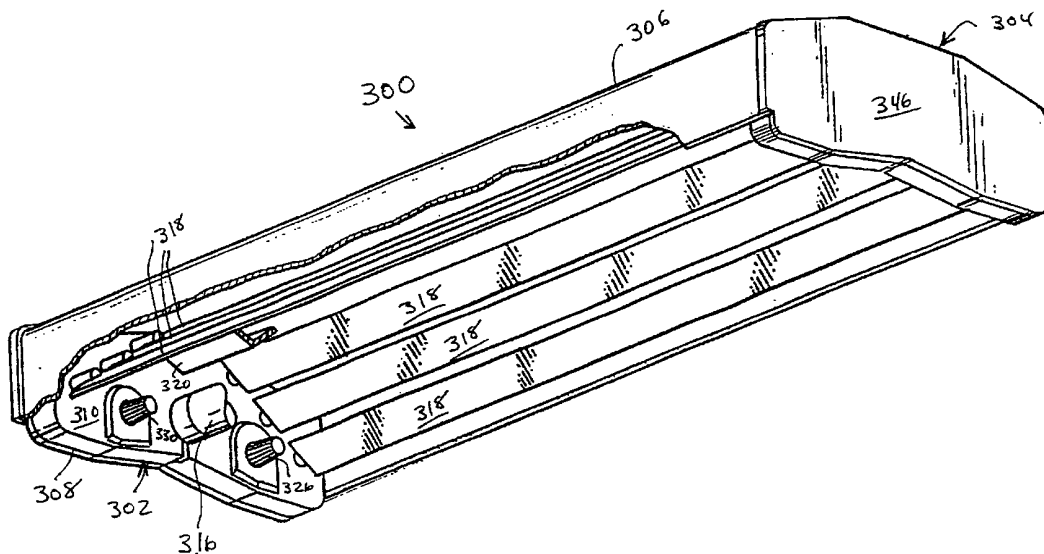

(57) Abstract: A module (302) for forming a modular luminaire (300), in cooperation with the second module (304), has a housing (308) with a cavity. The housing (308) is designed to be mounted within a luminaire frame or to one end of a luminaire shell (306). The module includes at least one bulb holder (314) that is supported by the housing (308) and multiple rotatably adjustable reflector holders, also supported by the housing (308). The holders are each designed to engage one end of an elongated reflector (318) so as to support it. The module also includes at least one adjustable knob (326) that allows the rotational position of at least one of the reflector holders to be adjusted.



WO 01/14792 A1

Luminaire Module Having Multiple Rotatably Adjustable Reflectors

Field of the Invention

This invention relates to a luminaire, and more particularly, to a luminaire having adjustable reflectors positionable to increase efficiency and energy conservation.

Background of the Invention

5 Luminaires or light fixtures for use with fluorescent bulbs have been in use for many years. Luminaires typically have rectangular box-like bodies which are adapted to be mounted in ceilings. The luminaire is generally provided with some type of reflectors positioned longitudinally behind or alongside of the fluorescent bulb to reflect light outwardly from the luminaire into the area desired to be lit.

10 Recently, energy conservation and efficiency of luminaires has been improved by the use of reflectors formed of specular material, such as silver or aluminum. These materials reflect light with greater precision than previous materials and permit the lighting engineer to control the manner in which the light is reflected.

 State of the art luminaires are currently custom manufactured to meet luminosity
15 criteria desired for the installation site. To ensure the installation of the most suitable lighting fixtures, on-site measurements are taken, appropriate reflector designs are chosen, and the reflector material, usually in the form of sheet metal, is bent or molded into reflectors composed of many precise angles at which the light is to be reflected without causing unsightly overlap with the resultant beams of light. Such a procedure is
20 time consuming and expensive. If the measurements are not carefully taken, it may be necessary to rebuild the luminaire or to make other adjustments which lead to diminution of the efficiency of the energy utilized.

It is also known to provide a luminaire with movable reflectors which may be positioned to change the physical dimensions of the light column produced by the light fixture, such as disclosed in U. S. Patent No. 3,099,403 to Strawick.

It is also known as disclosed in U. S. Patent No. 3,166,253 to provide a luminaire
5 having a plurality of movable slats or reflectors positioned outwardly from fluorescent bulbs. The reflectors are movable together like a Venetian blind to simulate natural light coming through a Venetian blind.

However, none of the presently known devices provide the necessary adjustments to increase energy efficiency and energy conservation.

10 Accordingly, it is desirable to provide a luminaire which has adjustable and interchangeable reflectors which are easily positionable to provide maximum efficiency for a full range of applications or adjusted for a different application.

Summary of the Invention

Thus disclosed is a novel luminaire having an outer body and a support structure
15 for mounting of both fixed and pivotable reflectors. The support structure is positionable within the body to widen or narrow the width of the beam of light emitted from the luminaire. Additionally, the support structure can be angled within the body to provide an asymmetrical light beam if desired. The movable reflectors are mounted to pivotal mounts connected to positioning rods to provide precise adjustment of the directional
20 light reflectivity. The reflectors are mounted to brackets to permit ready substitution of reflectors having different reflection characteristics. Alternatively, the luminaire can be provided with a two-sided or three-sided reflector. Each of the sides having different

reflective characteristics. The reflectors are pivotable so that the side with the desired characteristics can be chosen.

Also disclosed is a novel reflector assembly for reflecting light from a bulb in a luminaire. The luminaire is of the type having an elongated body with a top and a pair of
5 sidewalls defining an opening for permitting a beam of light to be emitted. The luminaire also has first and second ends and supports a bulb in the elongated body between the light emitting opening and the top. The reflector assembly includes a reflector support unit which can be mounted within the body of the luminaire between the opening and the top. The ends of the support unit are configured to interconnect with the ends of the
10 luminaire body and are independently, vertically adjustable in a linear direction so as to adjust the distance between each end of the support unit and the corresponding end of the opening in the luminaire body. The reflector assembly includes one or more reflectors mounted to the support unit that reflect light from the bulb. In some embodiments, a plurality of reflectors is included, each positioned to reflect a portion of the light coming
15 from the luminaire bulb. In some embodiments, the reflectors are pivotally mounted to the support unit so that they can pivot around their longitudinal axis.

Additionally, there is disclosed a modular luminaire and the modules for constructing such a module luminaire. The modules include a housing with a cavity therein. The housing is either configured to mount within a luminaire frame or to
20 connect to the end of a luminaire shell and to cooperate with the second module so as to form a complete luminaire. The module has at least one bulb holder that is supported by the housing and a plurality of rotatably adjustable reflector holders supported by the housing. The rotatably adjustable reflector holders are designed to engage the ends of elongated reflectors. The module also has at least one geared reflector adjuster to adjust

the rotational position of at least one of the reflector holders. The reflector adjuster is at least partially disposed in the cavity of the housing.

Finally, there is disclosed a novel means of connecting directional luminaires to remote control communications systems to direct the illumination pattern of one or more directional luminaires onto the areas of interest from a remote site, in accordance to a building-wide illumination strategy, or the preferences of individual users. Besides disclosing the mechanical and electrical means of directing light onto the areas of interest in accordance with these preferences, also disclosed is a means of establishing a communication protocol by which this strategy may be coupled with state of the art dimmable ballasts for fluorescent fixtures, to provide an overall illumination strategy further increasing the quality and efficiency of lighting systems.

A more complete understanding of this invention may be obtained from the following detailed description as well as taken with the accompanying drawings.

Description of the Drawings

Figure 1 is a partially exploded perspective view of a luminaire according to the invention;

Figure 2 is a cross-sectional view of the luminaire taken along lines 2-2 of Figure 1;

Figure 3a is a schematic end view of the luminaire with the support unit in a lowered position producing a wide distribution beam of light;

Figure 3b is a schematic view of the luminaire with the support unit in a raised position producing a narrow distribution beam of light;

Figure 4 is a perspective view of an adjustment mechanism for the movable reflectors in accordance with the invention;

Figure 4a is a partial side view of a mounting mechanism and a reflector;

Figure 5 is a first alternative embodiment of an adjustment mechanism for the
5 movable reflector;

Figure 6 is a perspective view of a second alternative adjustment assembly for the reflectors;

Figure 7 is a perspective view of a two-sided reflector in accordance with the invention;

10 Figure 8 is a perspective view of a three-sided reflector in accordance with the invention;

Figure 9a is a perspective view of a reflector having a flat reflective surface;

Figure 9b is a perspective view of a reflector having a concave reflective surface;

Figure 9c is a perspective view of a reflector having a convex reflective surface;

15 Figure 10 is a perspective view of a reflector assembly according to the present invention mounted in a luminaire body with a portion of the luminaire body cut away to show the adjustment mechanism;

Figure 11 is an end view of a reflector assembly according to the present invention showing one embodiment of an adjustment mechanism for the pivotally
20 mounted reflectors;

Figure 12 is an end view of a reflector assembly according to the present invention having a different adjustment mechanism;

Figure 13 is a diagram showing a light ray being reflected from a specular surface;

Figure 14 is a diagram of a light beam being reflected from a diffuse surface;

Figure 15 is a diagram showing light being reflected from reflectors located in a plane positioned such that the reflector assembly creates a narrow reflected light beam;

Figure 16 is a diagram showing reflectors located in a plane positioned such that
5 the reflector assembly creates a wide reflected beam;

Figure 17 is a diagram showing light being reflected from a group of reflectors adjusted so as to create a center weighted, focused distribution of light;

Figure 18 is a diagram showing light being reflected from a group of reflectors adjusted so as to form a laterally centered distribution of light;

10 Figure 19 is a diagram showing light being reflected from a group of reflectors adjusted so as to form a fanned distribution of light;

Figure 20 is a diagram showing light being reflected from a group of reflectors adjusted so as to form a laterally fanned distribution of light;

Figure 21 is a view of adjustment and coordinating gears showing the variation in
15 diameter;

Figure 22 is a view of two adjustment gears and an alternative coordinating gear;

Figure 23 is a perspective view of a modular luminaire assembled with a pair of modules according to a further aspect of the present invention;

Figure 24 is an elevational view of the inward surface of one of the modules used
20 in assembling the luminaire of Figure 23, with a portion of the inward surface cutaway to show the geared reflector adjustor in the module;

Figure 25 is an elevational view of the inward surface of the other module used in constructing the luminaire of Figure 23 with a portion of the inward surface cutaway to show the internal structure;

Figure 26 is a exploded perspective view showing a modular luminaire system according to the present invention being assembled into an opening in a ceiling;

Figure 27 is a schematic view showing different ways in which modules, each having three rotatably adjustable reflectors on each side of a central stationary reflector,
5 can be combined so as to form luminaires of various sizes;

Figure 28 is a schematic view showing different ways in which modules, each having two rotatably adjustable reflectors on each side of a central stationary reflector, can be combined so as to form luminaires of various sizes;

Figure 29 is a schematic view showing different ways in which modules, some
10 having rotationally adjustable reflectors on one side of a stationary central reflector and two rotatably adjustable reflectors on the other side of the central reflector, can be combined so as to form luminaires of various sizes;

Figure 30 is a sketch showing a pair of four lamp modules designed for applications requiring large luminaires;

15 Figure 31 is a sketch showing a comparison between a module designed for mounting within the larger luminaire housing and a module designed to form the end portion of a self-contained modular luminaire;

Figure 32 is a transparent perspective view of an industrial version of luminaires assembled with a pair of modules according to the present invention, with the luminaire
20 shell removed;

Figure 33 is a perspective view of the luminaire of Figure 32, further with the covering for the light opening removed for clarity;

Figure 34 is a perspective view of the luminaire of Figure 32 showing just the pair of modules and the luminaire shell;

Figure 35 is an elevational view of a luminaire module according to the present invention including an adjustor drive for adjusting the reflector positions; and

Figure 36 is a schematic showing a control system for a luminaire system according to the present invention including motorized reflectors and other features.

5

Detailed Description of the Preferred Embodiments

A luminaire 10 for a fluorescent light 12 according to the invention is best shown in Figures 1 and 2. The luminaire 10 is suitable for mounting in a ceiling suspended or recessed in a ceiling or wall (not shown). The luminaire 10 includes a rectangular box-like body 14 having an opening for accepting a conventional light (not shown). The body
10 14 has a top 16 and a pair of sides 18 which extend between a pair of ends 20. The body 14 is formed of a rigid, heat resistant material such as aluminum.

A support unit 22 is adjustably mounted to inner sides 26 of each end 20 of the body 14. Two vertically aligned rows of threaded apertures 24 are formed in the ends 20 for receiving bolts 28 for mounting the support unit 22 to the body 14.

15

As discussed more fully below, and shown in Figures 3a and 3b, the rows of apertures 24 permit mounting of the support unit 22 in a range of positions to vary the width of the projected beam of light. In a raised position shown in Figure 3b, the support unit 22 projects a narrow width beam 30 of light. In a lower position, shown in Figure 3a, the support unit 22 projects a wide width beam 32 of light. The support unit 22 may
20 be angled with respect to the opening 21 for producing an asymmetric beam of light.

As shown in Figure 2, the support unit 22 includes a pair of end pieces 40, 41 supporting the fluorescent bulb 12, a fixed center reflector 34, a pair of fixed side reflectors 36 and two pairs of movable reflectors 38. The end pieces 40, 41 are generally

rectangular in shape having an inner edge 44, outer edge 46, and a pair of side edges 48. As discussed more fully below, the end piece 40 is spaced apart from the inner surface 26 of the housing 14 by spacer brackets 42. The ends of the fluorescent bulb 12 are received in sockets 50 mounted on each end piece 40, 41. The bulb 12 thus extends along a longitudinal axis within the body 14 and support member 22. An electronic ballast 52 is also mounted on the end piece 40.

The fixed center reflector 34 is mounted by brackets to each end piece 40, 41. The center reflector 34 has two lateral sides 54 extending in a Δ from a corner 56. The corner 56 of the Δ is mounted between the socket 50 and the inner edge 44 of the end pieces. The sides 54 of the center reflector 34 extend parallel with the longitudinal axis of the fluorescent bulb 12 to reflect light through the opening 21.

The fixed side reflectors 36 are mounted on either side of the bulb 12 adjacent the outer edge 48 of the end pieces 40, 41. In the preferred embodiment, the fixed reflectors 36 extend along a plane which extends parallel to the longitudinal axis of the fluorescent bulb 12 and intersects the outer edge 58 of each side 54 of the center reflector. The fixed reflectors 36 are made of suitable rigid material and are coated to reflect light. The reflectors 34, 36 may be provided with any of a variety of coatings or materials to provide either spectral reflection or diffuse reflection. For instance, silver coating will provide a reflection with a minimal diffuse reflection, while a white enamel coating will provide a relatively low spectral reflection with a relatively great diffuse reflection. These types of reflection are illustrated in Figures 13 and 14. Figure 13 shows how light is reflected from a specular surface such as one with a silver coating. Figure 14 shows how light is reflected from a diffuse surface such as one having a white enamel coating.

- 10 -

As best shown in Figures 1, 2, 4 and 4a, the movable reflectors 38 are mounted to the end pieces by an adjustment mechanism including mounting brackets 42 and an adjustment rod 74. The mount 62 has a shaft 66 extending from a flange 68 for mounting the movable reflector 38. The shaft 66 is positioned through an aperture 72 in the end piece with the flange 68 extending outwardly from the inner surface of the end piece. A gear wheel 70 is mounted on an opposite end of the rod 74 extending into the space formed by the spacer bracket 42 between the end piece 40 and the body 14.

As best shown in Figure 4, an adjustment rod 74 having a worm gear 76 is mounted in meshing engagement with each gear wheel 70 by the pair of spacer brackets 42. Each adjustment rod 74 has an outer end having a head portion 78 having a slot 80 for accepting a blade of a screwdriver for rotating the rod 74. The outer surface may be grooved or knurled to facilitate rotation by hand. The worm gear 76 is positioned between a pair of cylindrical portions 82 which are received in an aperture 83 of each of the respective spacer brackets 42. An annular flange or stop 84 is formed on the rod to abut each bracket 42 to position the head portion 78 of the rod near the outer edge 46 of the end piece and position the worm gear 76 in engagement with the gear 70.

A first alternative embodiment of the adjustment mechanism is shown in Figure 5. A rod 86 is formed with a pair of worm gears 76 to engage a pair of gear wheels 70 to adjustment of a pair of reflectors simultaneously.

A second preferred embodiment of the adjustment mechanism is shown in Figure 6, in which the end pieces of the support unit are mounted directly to the body without brackets 42. The reflectors 38 are pivotally mounted by a mount 90 which has a flange 68 extending from a disk 92 mounted to a shaft 94 which is formed to extend through the bore 96 which is formed through both the support unit 22 and the body 14. The end of

the shaft 86 may be provided with a slot 80 as above or knurled to accept a knob 101. A disk 98 having a collar 100 and set screw 102 is mounted to secure the shaft 86 in position in the bore 96.

As shown in Figure 4a, each rotating reflector 38 is rectangular and formed of a rigid material, such as aluminum or fiberglass. It is advantageous to proportion the width of the reflector to range between the diameter and circumference of the lamp, for instance, between 2" and 4.5". The length of the reflector 38 is approximately equal to the length of the fluorescent bulb 12. This length can exceed 70 inches in length. At least one hole 104 is formed at each end of the reflector 38 for receiving a screw 106 for attachment to the flange 68 of the mount. The reflector is shown in Figure 4 with a flat surface. However, other surface shapes, such as concave or convex, can be used to provide the desired optics. As shown in Figures 7 and 8, a two surface reflector 110 or a three surface reflector 112 may be used. The two surface reflector 110 has a flat surface 114 and a concave surface 116. However, any other shape can be provided. The surfaces may have the same shape with different coatings. The two surface reflector 110 allows the user the option of rotating the reflector 110 from flat surface 114 to a concave surface 116 according to the illumination criteria used.

As shown in Figures 8, 9a, 9b, and 9c, the three surface reflector 112 can be produced by combining a flat surface reflector 118 as shown in Figure 9a, a concave surface reflector 120 as shown in Figure 9b, together with a convex surface reflector 122 as shown in Figure 9c. The reflectors are joined by fastening angled flanges 106 together.

Although shown with two pairs of reflectors 38, three pairs or more may be provided. The spacing between the reflectors 38 permits an effective flow of cooling air to flow through the luminaire to cool the fixture.

Referring now to Figure 10, a second preferred embodiment of the present invention is shown. In this embodiment, the invention comprises a reflector assembly 200 which is designed to reflect light from a bulb 212 in a luminaire 210. This embodiment differs from the earlier embodiment in that the bulb 212 is directly supported by the luminaire 210 rather than by the reflector assembly 200. The reflector assembly 200 of this embodiment can therefore be retrofit to an existing luminaire without modifying the bulb mounting wiring and position. Alternatively, the reflector assembly 200 can be used as part of a new luminaire.

The luminaire 210 has a body 214 made up of a top 216 and a pair of sides 218 which extend between a first end 220 and a second end 221 of the luminaire 210. The sides 218 define an opening 222 for permitting a beam of light to be emitted. The light emitted from the luminaire is made up of two parts, a direct light beam and a reflected light beam. The direct light beam is formed by the light which radiates directly from the bulb 212 out through the opening 222. The bulb 212 radiates in other directions as well and it is the function of the reflector assembly 200 to reflect this light back through the opening 222 as a reflected light beam. The luminaire 210 supports the bulb 212 in the body 214 between the opening 222 and the top 216. The second end 221 of the luminaire 210 has been removed in Figure 10 to more clearly illustrate the invention.

The reflector assembly 200 includes a reflector support unit 224 which includes a first end 226 and a second end 228. The reflector support unit 224 is configured to be mounted within the body 214 of the luminaire 210 between the opening 222 and the top

216. When installed in the luminaire body 214, the first end 226 of the reflector support unit 224 is adjacent the first end 220 of the luminaire body 214 and the second end 228 of the reflector support unit 224 is adjacent the second end 221 of the luminaire body 214. The ends 226 and 228 of the support unit 224 are designed to be interconnected with the adjacent ends 220 and 221 of the luminaire body 214 so that each end 226 and 228 of the reflector support unit 224 is independently, vertically adjustable in a linear direction so as to adjust the distance between each end, 226 and 228, of the support unit 224 and the opening 222 of the luminaire body 214. By adjusting the distance between the reflector support unit 224 and the opening 222 of the luminaire body 214, the shape of the reflected light beam emitted from the luminaire 210 can be adjusted as was shown in Figures 3a and 3b. In this embodiment, the direct light beam projecting downward from the bulb 212 will not be affected by repositioning the reflector support unit 224. However, the reflected light beam from the reflector assembly 200 will be affected by repositioning the support unit 224. It is also possible to mount the reflector assembly 200 within the luminaire body 214 at an angle relative to the opening 222. This may be desirable where the application requires a non-symmetrical reflected beam of light.

The reflector assembly 200 can be mounted within the luminaire body 214 in any of a number of ways as will be clear to one of skill in the art. As was discussed earlier and illustrated in Figure 1, bolts 28 which engage threaded apertures 24 may be used. This approach is also illustrated in Figure 10 which shows the first end 226 of the support unit 224 being interconnected with the first end 220 of the luminaire body 214 using bolts 28 which engage threaded apertures 24. A plurality of threaded apertures 24 may be provided in the ends 220 and 221 of the luminaire body 214 to allow for adjustment in the position of the reflector assembly 200.

An alternative approach is shown with the second end 228 of the support end 224. On this end, support brackets 229 are shown attached to the second end 228 of the support unit 224. The support brackets 229 can serve a variety of functions. First, the support brackets 229 support the second end 228 in an offset position from the second end 221 of the luminaire body 214 so as to provide clearance for an adjustment mechanism, such as the one discussed below. Secondly, the support brackets 229 provide a means to interconnect the end 221 of the luminaire body 214 with the end 228 of the support unit 224. Depending on the application, especially where a retrofit is contemplated, it may be necessary to adapt the luminaire body 214 so that the reflector assembly 200 can be supported therein. Support brackets 229 of various sizes and shapes can be used to adapt the luminaire body 214. The support brackets 229 would first be mounted to the inside of the end 221 of the luminaire body 214 using screws or bolts or other connection means. The brackets 229 would then provide a variety of attachment points for interconnection with the end 228 of the support unit 224 thereby allowing adjustment in the position of the connector assembly 200.

Other interconnection means are also possible. For example, rivets may be used to interconnect the ends 226 or 228 of the support unit 224 with the ends 220 or 221 of the luminaire body where easy adjustment of the position of the reflector assembly 200 is not required. This would simply require drilling a hole through the end 226 or 228 of the support unit 224 and through the end 220 or 221 of the luminaire body 214 and using a rivet to interconnect the two holes. Rivets could also be used to connect a bracket 229 to either the luminaire body 214 or the support unit 224. Alternatively, support unit 224 may include tabs which extend outwardly from the ends 226 and 228. The luminaire body 214 may include holes, or holes may be added, so that the tabs on the support unit

224 may engage the holes in the body 214 of the luminaire 210. Yet other interconnection means are also possible as will be clear to one of skill in the art. This includes gluing or welding the support unit 224 to the body 214 or ultrasonically welding the two together if they are plastic.

5 The reflector assembly 200 also includes one or more reflectors. In the illustrated embodiment, the reflector assembly 200 includes a fixed center reflector 230 positioned directly above the bulb 212. For purposes of description, a central plane is defined as longitudinally bisecting the support unit 224 such that it passes through the opening 222 of the luminaire body 214 when the support unit 224 is mounted within the luminaire
10 body 214. The central plane longitudinally bisects the reflector support unit 224 such that the longitudinal axis of the bulb 212 and the longitudinal axis of the fixed center reflector 230 are contained within the central plane. Using the central plane as a reference, three reflectors are positioned on each side of the central plane. On one side of the central plane is a first reflector 232, a third reflector 236 and a fifth reflector 240. On
15 the other side of the central plane, and symmetrical with the other three reflectors, 232, 236, and 240, are a second reflector 234, a fourth reflector 238, and a sixth reflector 242. Alternatively, the reflector assembly 200 may include fewer or a greater number of reflectors. Also, the reflectors may have two or more sides as shown in Figures 7 and 8. The reflectors may have either a specular or diffuse surface and may be flat, concave, or
20 convex depending on the application.

Like in the earlier described embodiments, the reflectors 232-242 are pivotally mounted to the support unit 224 such that each reflector can pivot with respect to the support unit about its own longitudinal axis. Further, the reflectors 232-242 are preferably detachably mounted to the reflector support unit. A preferred approach for

- 16 -

interconnecting reflectors and the reflector support assembly 224 was discussed earlier and shown in Figure 4a.

Referring back to Figures 4a and 6, details of one preferred approach to supporting the reflectors 232-242 is illustrated. Each end of the reflectors are mounted to
5 a mount 62. The mount 62 includes a flange 68 for mounting an end of a reflector. The reflectors have holes 104 which align with holes in the flange 68 and accept screws 106 for holding the reflectors to the mount 62. The mount 62 also includes a shaft 66 extending from the flange 68. Referring also to Figure 10, the shafts 66 of the mounts 62 pass through holes in the ends 226 and 228 of the reflector support unit 224. In this way,
10 the reflectors 232-242 are supported for pivotal movement. Adjustment gear wheels are mounted to the mount 62 at the end of the shafts 66 opposite the flanges 68 at one end of the reflectors 232-242. In this way, the position of each adjustment gear wheel determines the pivotal position of each reflector.

Several different adjustment mechanisms are envisioned with the ones illustrated
15 in Figures 10, 11, and 12 being preferred. As discussed above, adjustment gear wheels are interconnected with the reflectors 232-242 by the mounts 62. A first adjustment gear wheel 244 controls the first reflector 232, a second adjustment gear wheel 246 controls the second reflector 234, a third adjustment gear wheel 248 controls the third reflector 236, a fourth adjustment gear wheel 250 controls a fourth reflector 238, a fifth adjustment
20 gear wheel 252 controls the fifth reflector 240, and a sixth adjustment gear wheel 254 controls the sixth reflector 242. The adjustment mechanism also includes coordinating gears which mesh with and interconnect the adjustment gear wheels so that the adjustment gear wheels, and the reflectors, move in a coordinated manner. A first coordinating gear 256 is positioned adjacent and engages both the first and the third

adjustment gear wheels 244 and 248 so that the first coordinating gear 256 and the first and third adjustment gear wheels, 244 and 248, rotate together. Likewise, a second coordinating gear 258 is positioned adjacent and engages both the third adjustment gear wheel 248 and the fifth adjustment gear wheel 252. A third coordinating gear wheel 260
5 and a fourth coordinating gear wheel 262 likewise engage the adjustment gear wheels 246, 250, 254 on the other side of the luminaire thereby coordinating their movement.

As shown, the adjustment gear wheels 244-254 are each identical in size to each other. The coordinating gears 256-262 are also identical in size to each other but are smaller in size than the adjustment gear wheels 244-254. With this configuration, the
10 first, third, and fifth, 232, 236, 240, reflectors all rotate an identical amount when any one of them is turned. Alternatively, the sizes of the adjustment gear wheels 244-254 and the coordinating gears 256-262 may be adjusted so that various reflectors turn by different amount. It is desired that the gear sizes be chosen such that the reflectors nearest the bulb rotate less than the reflectors further from the bulb. In one preferred arrangement, for a
15 given amount of adjustment, the reflector nearest the bulb rotates half the amount of the reflector second from the bulb which in turn rotates half as much as the reflector furthest from the bulb. For example, for a given adjustment of drive gear 266, reflector 232 will rotate 5 degrees, reflector 236 will rotate 10 degrees, and reflector 240 will rotate 20 degrees. The actual ratios of the gear sizes will depend upon the desired
20 reflection pattern and the application of the luminaire. The variation in rotation ratios for a given adjustment can be achieved in several ways as will be clear to one of skill in the art. For example, the adjustment gear wheels 244-254 may be of different diameters so as to achieve different amounts of rotation for the various reflectors. One particularly preferred embodiment of this approach is illustrated in Figure 21. This figure adopts the

- 18 -

numbering as used on the coordinating gears and adjustment gears on the left half of the luminaire 210 in Figure 10. However, for ease of illustration, the gears are arranged in a straight line. Depending on packaging constraints, the gears may be moved out of the straight line configuration. In Figure 21, a knob gear 276 is connected to an adjustment

5 knob (not shown) and has twelve teeth. Knob gear 276 drives the drive gear 264 which has ten teeth. It in turn drives the sixth adjustment gear wheel 254 having twenty teeth which in turn drives the fourth coordinating gear 262 having ten teeth, which drives the fourth adjustment gear wheel 250 having twelve teeth, which in turn drives the third coordinating gear 260 having ten teeth, which in turn drives the second adjustment gear

10 wheel 246 having ten teeth. Obviously, reflectors attached to the adjustment gear wheels 254, 250, 246 rotate by differing amounts when the knob gear 276 is rotated. By varying the diameter and number of teeth on the adjustment gear wheels 254, 250, 246, the rotation ratios may be selected. Alternatively, the coordinating gears may have different gear ratios on each of their sides so that the adjustment gear wheels which mesh with the

15 coordinating gear turn by different amounts depending on which side of the coordinating gear engages them. This may be achieved by forming the coordinating gear as two half-gears of different diameters as shown in Figure 22. In Figure 22, a left adjustment gear wheel 280 and a right adjustment gear wheel 282 both mesh with an intermediate coordinating gear 284 positioned therebetween. As shown, the intermediate coordinating

20 gear 284 has a large diameter portion 286 and a small diameter portion 288 as if the intermediate coordinating gear 284 is formed with pieces of a large diameter gear and a small diameter gear. The intermediate coordinating gear 284 is arranged such that the large diameter portion 286 meshes with the left adjustment gear wheel 280 while the small diameter portion 288 meshes with the right adjustment gear wheel 282. Therefore,

for a given rotation of the left adjustment gear wheel 280, the right adjustment gear wheel 282 rotates by a lesser amount but in the same direction as the left adjustment gear wheel 280. Alternatively, the coordinating gears may be made up of a pair of stacked gears with one of the stacked gears engaging one adjustment gear wheel and the other stacked gear engaging the other adjustment gear wheel. Obviously, these various approaches to
5 varying the rotation ratios may also be combined to provide further flexibility.

Also shown in Figures 10 and 11, are drive gears 264 and 266 which engage the outermost adjustment gear wheels 252 and 254 respectively. These drive gears are used to adjust the entire adjustment mechanism. For example, the drive gears 264 and 266
10 may be accessed from below the luminaire 210 and rotated thereby adjusting the position of the reflectors 232-242. The drive gears 264 and 266 are each connected to a knob 265, 267 similar to the one shown in Figure 6 at 101. A shaft extends from each of the drive gears 264, 266 through the end 228 of the support unit 224 and each has the knob 265, 267 mounted on the inside of the second end 228 of the support unit 224. This allows
15 adjustment of the position of the reflectors 232-242 from inside the luminaire opening 222. A spring may be positioned under the knob to lock the mechanism to avoid movement. Other locking means may also be used.

Referring now to Figure 12, the worm drive adjuster 268 is substituted for the drive gears 264 and 266. The worm drive adjuster comprises a vertical shaft 270 with a
20 knob 272 on one end and a worm drive gear 274 on its other end. The worm drive gear 274 engages adjustment gear wheel 254 so that the position of the reflectors may be adjusted by rotating knob 272. A second worm drive adjuster may be included on the other side of the reflector support unit to adjust the reflectors on the other side or additional gears may be added so as to interconnect the adjustment gear wheels on each

side of the reflector support unit. Alternatively, a longer shaft with several worm drive gears may be used to engage several adjustment gear wheels similar to the approach shown in Figure 5. As will be clear to one of skill in the art, many other variations on the adjustment mechanism are possible. For example, the adjustment gear wheels may include stops which prevent their rotation beyond a certain position so that the end user of the reflector assembly 200 cannot adjust the reflectors beyond their operating range.

Referring now to Figures 15 and 16, the effect of reflector positioning is illustrated. In Figure 15, light is shown radiating from a fluorescent bulb 212 and being reflected from the first, third, and fifth reflectors, 232, 236, 240. The reflectors each have their longitudinal axis located in a plane A which is defined as a first reflector plane. The central plane, discussed earlier, is shown as a vertical line containing the longitudinal axis of the fluorescent bulb 212 and is marked as B. The first reflector plane and the central plane B intersect to define a line which is parallel to the longitudinal axes of the reflectors 232, 236 and 240. The angle formed between the central plane B and the first reflector plane A is defined as a first mounting angle and is illustrated in Figure 15 as θ_1 . Referring now to Figure 16, the reflectors 232, 236 and 240 are once again shown reflecting light emanating from the fluorescent bulb 212. However, in this case, the first reflector plane A is repositioned so that first mounting angle θ_2 is much larger than first mounting angle θ_1 in Figure 15. As shown in the figures, the direction and the width of reflected beams are changed. Beam C in Figure 15 and beam D in Figure 16 illustrate only that portion of the reflected light beam which is reflected from the fifth reflector 240. In Figure 15, with a narrow first mounting angle θ_1 , the reflected beam C is narrow and reflected almost vertically so that it will illuminate an area near to the central plane B. In Figure 16, the light beam D reflected from the reflector 240 positioned at a wide

first mounting angle θ_2 is wider than the beam C and is directed outwardly away from the central plane B. By changing the mounting angle of the reflector assembly of the present invention, the total width of the reflected beams from the reflector assembly can be limited or expanded.

5 It should be noted that reflector 240 is positioned such that the reflective surface lies in the first reflector plane A and it is assumed that a flat reflective surface is used. If the reflector 240 were rotated counterclockwise, it would no longer intercept as much light from the bulb with some light passing behind the reflector and not being reflected through the opening. Therefore, the position shown for reflector 240 is the furthest
10 counterclockwise position for efficient reflection of light. Also, the distance of beam C from the central plane B is the furthest from the central plane B that light can be reflected using a flat reflective surface lying in the reflector plane A.

 As can be seen, the first mounting angle θ_1 or θ_2 controls how wide a beam of light can be reflected from the reflector located on the first reflector plane. Therefore, a
15 reflector assembly with a narrow mounting angle such as θ_1 in Figure 15 would be limited in how wide of a reflected beam C it can create. A reflector assembly with a wide mounting angle such as θ_2 in Figure 16 will be able to reflect light in a much wider beam and much further from the central plane B. Depending on the application, different mounting angles are desirable as will be clear to one of skill in the art. Generally, the
20 mounting angle should not be less than 20 degrees or greater than 90 degrees. Also, the reflectors 234, 238, and 242 on the other side of the central plane B are preferably positioned in a second reflector plane which intersects the central plane at a second mounting angle. This second mounting angle may be the same as the first mounting angle or a different angle depending on the application.

Referring now to Figures 17-20, a variety of light reflection patterns are shown indicating a variety of patterns which can be created by repositioning the six reflectors 232-242 in the reflector assembly. In Figure 17, the reflectors 232-242 are positioned such that the reflected beam created by each of the six reflectors is focused on the area
5 directly below the bulb 212. The light reflected from each of the six reflectors also overlaps. This greatly increases the amount of light available in the area directly below the bulb 212. Depending on the configuration, the illumination reflected from each of the reflectors 232-242 is approximately equal to the illumination created by the light radiating directly from the bulb 212. Therefore, by focusing beams created by each of
10 the reflectors 232-242 on the area below the bulb 212, the illumination available directly below the bulb 212 is substantially increased. The pattern created by the reflectors shown in Figure 17 is called a center weighted, focused distribution of light and is particularly useful where a great deal of illumination is needed in a small area.

In Figure 18, the reflectors 232-242 are shown positioned such that the reflected
15 beams of light are more spread out than they were for the position shown in Figure 17. Once again, the reflected light beams overlap. In this case they are more spread out to form a wider area of increased illumination. This pattern is called a laterally centered distribution of light and is particularly useful where increased illumination is needed in a somewhat larger area than is required for the pattern shown in Figure 17.

20 Figure 19 shows the reflectors 232-242 positioned such that reflected beams of light are spread out much wider than previously illustrated and the reflected light beams do not significantly overlap. This is a pattern that would be created with the reflective surfaces of the reflectors 232-242 on each side of the bulb 212 positioned in planes much as was shown in Figures 15 and 16. As can be seen, the reflected beams do not

illuminate the area directly below the bulb 212. This pattern is called a fanned distribution of light and may be useful where a very wide distribution of light is desired or where the area directly below the bulb 212 does not require additional illumination.

Figure 20 shows reflectors 232-242 positioned such that the reflected beams of
5 light are spread even more widely than the pattern shown in Figure 19. As explained earlier, this positioning allows some light to escape interception by the reflectors and pass behind them. However, this pattern allows for a very wide distribution of light. Depending on the positioning of the individual reflectors, the reflected light beams may overlap so as to create areas of more intense illumination. This pattern is called a
10 laterally fanned distribution of light and is particularly useful where the area below the bulb 212 does not require additional illumination such as if a luminaire is positioned directly above a partition wall.

As will be clear to one of skill in the art, other light patterns may be created by repositioning the reflectors. Also, the above discussed patterns may be combined such
15 that reflectors on one side of the bulb 212 focus light beneath the bulb while the reflectors on the other side of the bulb reflect light away from the location beneath the bulb 212. This may be desirable where the illumination needs are not symmetrical with respect to a luminaire. It should also be noted that the patterns shown in Figures 17-20 do not illustrate the light beam directly emitted from the bulb, earlier defined as a direct
20 light beam. The illustrated reflected light beams serve to reinforce the illumination provided by the direct light beam. Therefore, while the direct light beam will tend to provide a uniform level of illumination, the reflected light beams can be used to provide areas of increased illumination where needed.

Referring now to Figures 23-25, another aspect of the present invention will be discussed. According to this aspect of the present invention, a modular luminaire 300 is shown. The luminaire 300 includes a first, or master, module 302 that defines a first end of the luminaire 300, a second, or slave, module 304 that defines a second end of the luminaire 300 and an upper luminaire shell 306 that extends between and interconnects the master module 302 and the slave module 304, and also defines the sides and top of the luminaire 300.

The construction of the master module 302 may be best seen in Figure 24. The module 302 includes a housing 308 which has an inward surface 310 and an opposed outward surface 312 defining a cavity 313 therebetween. The module also has a bulb holder 314 designed to accept one end of a fluorescent bulb 316, part of which is shown in Figure 23. Alternatively, the housing may have a bulb holder designed to hold a non-fluorescent bulb or a fluorescent bulb with a different design. As with previous embodiments of the present invention, the luminaire 300 is designed to have a plurality of adjustable reflectors 318, as shown in Figure 23. If a central plane B is defined so that it passes through the center of the bulb holder 314 and bisects the housing 308 side to side, the reflectors 318 are arranged generally symmetrically about its central plane and above the bulb holder 314 so that light coming from a bulb 316 is reflected from the plurality of reflectors 318 and downwardly so as to illuminate a surface. Also located on the central plane is a stationary V-shaped reflector 320 that is positioned above the bulb 316 for reflecting light to the adjustable reflectors 316 as well out through the bottom of the luminaire 300. The central V-shaped reflector 320 is supported by a V-shaped support 322 on the inward surface 310 of the housing 308.

Referring to Figure 24, the adjustable reflectors 318 are each supported by rotatably adjustable reflector holders 324. These reflector holders 324 extend outwardly from within the housing 308, as shown in the cutaway portion on the right hand side of Figure 24. Within the housing, is a system of gears that coordinate movement of the reflector holders 324. This system of gears, along with an adjustable knob 326 form a system for adjusting the position of the reflector holders 324. The system includes the adjustment knob 326, three intermediate gears 328 and the reflector holders 324 which have adjustment gears 325 mounted at their bases. As shown, the adjustment knob 326 adjusts the reflector holders 324 on the right hand side of the module 302. The second adjustment knob 330 is provided on the left hand side of the module 302 for adjusting the reflector holders 324 on the left hand side. On the left hand side of the drawing, the internal gear system is hidden by the inward surface 310 of the housing 308. As will be clear to those of skill in the art, the gearing system for adjusting the adjustable reflector holders 324 may be modified in various ways so as to change how the reflectors move relative to one another, as has been explained with respect to earlier embodiments of the present invention.

Referring now to Figure 25, the slave module 304 will be described in more detail. The slave module 304 is similar to the master module 302 but differs in that it lacks an adjustment system for adjusting the position of the reflector holders. The slave module 304 includes a housing 332 and six adjustable reflector holders 334 that are supported by the housing 332. The right side of Figure 25 is cutaway to show the inside of the housing 332. As shown, the adjustable reflector holders 334 are not interconnected by a gear system, but rather are free to turn. However, to reduce complexity, the holders 334 may be a common part with the holders 324. The slave module 304 is designed to

- 26 -

be used with the master module 302 as shown in Figure 23. The reflectors 318 interconnect the adjustable reflector holders 324 on the master module 302 and the reflector holders 334 on the slave module 304. Depending on the design of the luminaire 300, the reflectors 318 are stiff enough that, when they are rotatably adjusted by the master module 302, the reflector holders 334 on the slave module 304 also turn. That is, a user adjusts the adjustment knobs 330 and 326 on the master module, which in turn adjusts the rotational position of the reflector holders 324, causing the position of the reflectors 318 to be adjusted. The reflector holders 334 in the slave module 304 just support the other end of the reflectors 318 and allow them to rotate freely. As will be clear to those of skill in the art, some embodiments of a luminaire using the modules may require the use of two master modules 302 rather than a master module and a slave module 304. That is, if the luminaire is very long, adjusting only a single end of the very long reflectors 318 may cause them to twist. Therefore it may be necessary to provide adjustment at both ends so that each end of each reflector may be rotated an equal amount to prevent a twisting.

Referring again to Figure 25, the internal structure of the central portion of the module is shown because the inward surface is cutaway. As shown, a portion of the bulb holder is disposed within the housing and has a rotational support 336 into which the end of the bulb is inserted and twisted. Conducting leads 338 then interconnect the contacts on the bulb with wiring holes 340, as shown in Figure 24. Wires may be run above the central reflector 320 from one end of the luminaire to the other by interconnecting the wiring holes 340. In this way, power can be run from one end to the other.

Referring now to each of Figures 23-25, assembly of the luminaire 300 will be discussed. As shown in Figure 23, a luminaire shell 306 interconnects the two modules

302 and 304. In Figure 24, the master module 302 has a groove or slot 342 that follows the upper perimeter of the housing 308. The slave module 304 in Figure 25 has a similar groove or slot 344 following its upper perimeter. The ends of the upper shell 306 are inserted into these two grooves, connected using any of a variety of mechanical interconnection methods, or adhesively attached. The central reflector 320 and adjustable reflectors 318 may then be attached to form a complete luminaire. In this way, a luminaire 300 is easily assembled and may be formed with any of a variety of lengths by changing the length of the shell 306 and the reflectors 318 and 320. As shown in Figure 23, the outward surface 346 of the slave module 304 is smooth to give a finished appearance.

Referring now to Figure 26, another embodiment of a modular luminaire system is illustrated. In this embodiment, modules are provided that mount within an existing housing or frame within a ceiling of a building so as to provide the benefits of the present adjustable reflector system. As shown, a ceiling 350, such as within an office building, has a recessed housing or frame 352 for a lighting fixture. According to the present invention, a master module 354 and a slave module 356 are provided which will mount within the housing or frame 352. These modules 354 and 356 are identical to the previously discussed modules except that their outward surfaces 358 include a variety of mounting devices for interconnecting each of the modules 354 and 356 with the housing 352. For example, the outward surface 358 of the slave modules 356 is shown to have two attachment holes 360 as well as several attachment pegs 362.

The pegs 362 may be provided and used where the housing has slots or holes which they may engage. Alternatively, the holes 316 may be used with mounting studs or screws. The modules 354 and 356 may be adjustably mounted within the housing 352

or may be placed in a stationary position. As discussed earlier in this application, the pattern of light reflected out of the luminaire can be changed by moving the reflector system upwardly and downwardly relative to the opening in the ceiling 350. If this is desired, the modules 354 and 356 may be adjustably mounted, such as by providing slots
5 to engage the posts 362.

As will be clear to those of skill in the art, many of the parts within the modules are interchangeable therebetween so as to reduce complexity. Also, a single module may be provided that can either be mounted within a luminaire frame, as in Figure 26 or, alternatively, be mounted to the end of a luminaire shell, as in Figure 23. In the
10 illustrated embodiment, the difference between a module designed to connect to a luminaire shell and one designed to connect to a luminaire frame are the slots for engaging the shell and the connectors on the outward surface of the module. In one preferred construction of the module, the outward surface is a molded piece of plastic and the inward surface is a second piece of molded plastic that is snapped together when the
15 module is assembled. The piece of plastic forming the outward surface is designed such that it extends beyond the piece of plastic forming the inward surface so as to define the slot or groove that engages the luminaire shell. Alternatively, this outward piece of plastic can extend just to the limits of the inward piece of plastic and include mounting devices such as holes and pegs. In this way, only the outward piece of plastic need be
20 changed to change the module from one design to mount to a shell to one design to mount to a frame. Alternatively, the same module may be used for either application.

One advantage to the modules of the previous figures is that they may be combined in various ways so as to provide larger or smaller luminaire arrangements. For example, in Figure 27, it is shown that a single module with three reflectors on each side

of the bulb, as shown at 366, may be used alone to provide a single width luminaire. This is shown at the top of Figure 27. Below this in Figure 27, a pair of identical modules 366 are shown side by side to illustrate that a pair of modules may be installed side by side in a larger housing to provide a large luminaire. Likewise, three and four luminaires are shown side by side in the bottom two rows of Figure 27. In this way, a very large luminaire may be provided while still providing the benefits of adjustable reflector systems.

Referring now to Figure 28, a smaller module 368 with two reflectors on each side of the bulb is shown. As with Figure 27, a single module 368 or multiple modules may be provided so as to provide a luminaire of different sizes.

Referring now to Figure 29, a symmetrical module 370 is shown with three reflectors on one side of the bulb and two on the other side of the bulb. A mirror image symmetrical module 372 may also be provided with two reflectors on one side and three reflectors on the other. By combining these modules 370 and 372, as shown in the first row of Figure 29, a larger luminaire may be created. As shown in the second row of Figure 29, a 2+2 module 368 may be combined with the asymmetrical modules 370 and 372 to provide a larger luminaire. Or, as in the third row, two 2+2 modules 368 may be provided in between the asymmetrical modules 370 and 372.

Referring now to Figure 30, a dual lamp module 374 is shown. This module differs from the prior modules in that it has two lamp holders 376 with reflectors between the lamps and to the outside. A total of four adjustment knobs are provided. A second dual lamp module 374 is also shown to illustrate that two modules may be combined to provide a very large luminaire.

Referring now to Figure 31, the two lamp module 374 of Figure 30 is shown at the bottom. At the top, a different two lamp module 376 is shown. This module 376 is an industrial version that, similar to the modules of Figures 24 and 25, is designed to form one end of a luminaire and includes a slot 378 to engage an upper shell. A luminaire assembled with a pair of the industrial modules 376 is shown in Figures 32-34. In these figures, two modules 376 and 378 are interconnected by an upper shell 380 to form a complete luminaire. It should be noted that these modules include ballast connectors 382 for connecting a ballast directly to the module. The earlier modules may also be provided with ballast connectors.

Referring now to Figure 35, a further aspect of the present invention will be described. As previously discussed, the use of adjustable reflectors as part of a luminaire allows for increased efficiency and flexibility of a lighting system. In many situations, luminaires are mounted such that adjustment of the adjustable reflectors that form a portion of the present invention is difficult or impossible. For example, the luminaires may be mounted in a very high ceiling or in a position such that they are not easily reached even with a ladder. Also, the persons who may wish to adjust a luminaire, such as workers in the area illuminated by the luminaires, may not have access to equipment sufficient to allow them to climb to the luminaire to make manual adjustments. According to a further aspect of the present invention, an electromechanical drive is provided for automatically rotating the reflectors, thereby avoiding the necessity of manually adjusting gears or knobs.

Referring to Figure 35, a luminaire module according to the present invention is generally shown at 400. This module is similar to the earlier discussed modules and includes a plurality of reflector mounts which are interconnected by a series of

adjustment gears. However, in this embodiment, a rotary adjuster drive 402 is mounted in each side of the module and intermeshed with the remaining adjustment gears so that the drive 402 may adjust reflector positions. As will be clear to those of skill in the art, the rotary adjuster drives 402 may be of a variety of types such as electromechanical, 5 rotary shaft decoders, servo drives, or others. These drives, 402, when energized, are operable to rotate the adjuster gears in either a clockwise or counterclockwise direction. The drives 402 include some type of electrical motor which interconnects with the power supply of the luminaire module 400. According to the present invention, rotary adjuster drives may be provided for use with any of the previously discussed embodiments of the 10 present invention. This includes the modular luminaires as well as the non-modular luminaires. The central processing unit 404 may be connected to a single luminaire or any number of luminaires so as to control a plurality of aspects of a lighting scheme.

The provision of the rotary adjuster drives 402 provides for an additional aspect of the present invention. Once the reflectors are electrically driven, direct access to 15 individual luminaires is no longer required. Instead, remote control devices may be provided for controlling the positions of the luminaire reflectors from a distance. These remote controls may be hard-wired or wirelessly in communication with the rotary adjuster drives. For example, reflector position controls may be provided near lighting controls in a building so that occupants of the building may adjust the illumination 20 pattern from a central control point. As will be clear to those of skill in the art, the controls may control individual luminaire reflector banks or may control multiple luminaires at the same time.

Referring now to Figure 36, a schematic of a control system for a luminaire having a rotary adjuster drive 402 is shown. In this embodiment, one or more rotary

adjuster drives 402 are interconnected with a central processing unit 404. This interconnection between the drive 402 and the central processing unit 404 may be any type of wired or wireless system. The central processing unit 404 is operable to control the motion and/or position of the rotary drive 402. For example, the rotary drive 402
5 may be an encoder such that it moves to a predetermined position in response to a signal from the CPU. Alternatively, the drive 402 may be a simple drive that is not position sensitive. Instead, the CPU may include control circuitry allowing it to position the drive and the reflectors in the luminaire in a particular position based on approaches known to those of skill in the art. For example, the CPU may drive the rotary drive to one extreme
10 of its motion to "zero" the position and then drive the drive 402 in the opposite direction for a predetermined time in order to place the reflectors in a known position. Alternatively, other types of feedback systems may be used. The central processing unit may also be programmed or include a pre-programmed lighting schemes so that a user may select certain program schemes, such as security lighting, maximum illumination, or
15 task lighting. The central processing unit may also communicate with other types of lighting devices such as individual desk lamps and various incandescent lamps throughout a building, such as exit and safety lighting.

According to a preferred additional aspect of the present invention, a dimmable ballast 406 is provided and is controlled by the central processing unit 404. In this way,
20 reflector position as well as illumination level may be controlled by the central processing unit. A communications interface 406 communicates with the central processing unit. The communication interface communicates with a remote control using any of a variety of communication mediums 408. For example, a communications interface may be wired to a central control box allowing a user to control luminaire

illumination level and lighting patterns. Alternatively, infrared transmission devices may be used so that a hand-held infrared remote may be used to control illumination and/or lighting patterns. Other examples of communication mediums include serial or parallel cable transmission systems, fiber optics cables, radio transmission systems, hand-held
5 controllers with one- or two-way transmission capability, and electrical power line transmissions. Other communication mediums will be apparent to those of skill in the art.

As a further extension of the present invention, a variety of sensors may communicate with a central processing unit for more complete or flexible control of the
10 luminaires connected thereto. A photosensor 410 and a motion detector 412 are shown in Figure 36 in communication with a central processing unit 404. These sensors 410 and 412 are merely illustrative of the type of sensors which may communicate with the central processing unit. For example, a photosensor may be provided on a remote control unit, such as a hand-held infrared control device, so that the central processing unit
15 receives feedback from the remote control concerning illumination level at the position of the remote control. In this way, the user may position the remote control where a particular level of illumination is required. The user may then press a "set illumination" button causing the CPU to adjust the various luminaires in the area until the desired illumination level is met. This process may be repeated for a variety of locations in order
20 to obtain a desired overall illumination level. Alternatively, a variety of photosensors may be provided in order to provide more information to the central processing unit 404. Alternatively, the photosensors may be permanently positioned in various locations so that the central processing unit may monitor illumination levels over time and thereby

determine when certain bulbs require illumination or when luminaires are not responding to adjustment commands.

A motion detector 412 may be useful in a variety of ways. For example, motion detectors may be provided in various locations within an office so that the central
5 processing unit may easily determine whether workers are present in the office space. As a further example, sensors may be provided for detecting the presence of human workers, such as heat detectors for sensing the presence of bodies. Various sensors may be combined so as to allow illumination to “follow” a worker as they proceed with their daily activities. This will also provide illumination to follow a security guard as the
10 guard makes his rounds after hours. Other uses will be apparent to those of skill in the art. As will be clear to those of skill in the art, a luminaire control system according to the present invention may be interconnected with or networked with other building systems so that the luminaire system cooperates with the security system, air conditioning system, and various safety systems. This is especially beneficial as part of an intelligent
15 building control system. As just one illustrative example, a central control system may control various systems in response to individualized work schedules such that illumination is only provided in a particular person’s work area during their normal working hours, or in response to their arrival as sensed by a building security system.

As a further aspect of the present invention, other aspects of a luminaire
20 according to the present invention may be motorized and remotely controlled. For example, the luminaire of Figure 1 includes the ability to adjust the position of a support unit with respect to a luminaire housing, in part to control cut off angles of illumination. As will be clear to those of skill in the art, this adjustability may be motorized in a variety of ways, such as linear drives, so that position of the supporting unit may be remotely

adjusted. This would include individually adjusting the two ends of the support unit so as to change illumination angles. Also, as previously discussed, different types of reflecting surfaces may be provided on various sides of a multi-sided reflector. The actuator drive may be operable to rotate these multi-sided reflectors to various positions such that
5 different reflector surfaces are in use. This provides additional control over illumination patterns. As a further alternative, the gear system shown in some embodiments may be eliminated and actuator drives provided for each individual reflector. This allows for complete adjustability.

While there have been described what are present to be the preferred
10 embodiments of the invention, it will be understood that various modifications may be made therein and the invention is intended to cover in the independent claims all such modifications as fall within the true spirit and scope of the invention.

I claim:

1. A module for mounting to a luminaire frame to form a luminaire assembly
2 in cooperation with a second module, the luminaire frame of the type having a pair of
spaced apart ends and an opening for permitting a beam of light to be emitted from the
4 frame, said module comprising:
 - a housing having a cavity defined therein, said housing being configured for
6 mounting to one of the ends of the luminaire frame;
 - at least one bulb holder supported by said housing;
 - 8 a plurality of rotatably adjustable reflector holders supported by said housing, said
holders each being configured to engage an end of an elongated reflector; and
 - 10 at least one geared reflector adjustor for adjusting the rotational position of at
least one of said plurality of reflector holders, said reflector adjustor being at least
12 partially disposed in said cavity.
2. The module according to claim 1, wherein said reflector holders are
2 disposed symmetrically about a central plane which bisects said module and passes
through said bulb holder.
3. The module according to claim 1, further comprising a stationary reflector
2 holder supported by said housing.
4. The module according to claim 1, wherein said housing includes an
2 electrical connector.

5. The module according to claim 4, further comprising an electrical
2 conductor interconnecting said electrical connector with said bulb holder.

6. The module according to claim 1, further comprising a ballast connector
2 for connecting a ballast to said module.

7. The module according to claim 1, wherein said geared reflector adjustor
2 comprises an adjustment knob for adjusting the rotational position of at least one of said
reflector holders.

8. The module according to claim 1, wherein said plurality of reflector
2 holders comprises at least a first and a second reflector holder, said reflector adjustor
comprising a first adjustment gear mounted to said first reflector holder, a second
4 reflector gear mounted to said second reflector holder, and an intermediate gear engaging
said first and said second reflector gears for coordinating their rotational movement.

9. A module for forming a luminaire assembly in cooperation with a second
2 module and a luminaire shell which extends therebetween, the luminaire shell having
ends, said module comprising:

4 a housing having a cavity defined therein, said housing further having a slot
configured to engage an end of the luminaire shell;

6 at least one bulb holder supported by said housing;

a plurality of rotatably adjustable reflector holders supported by said housing, said
8 holders each being configured to engage an end of an elongated reflector; and

at least one geared reflector adjustor for adjusting the rotational position of at
10 least one of said plurality of reflector holders, said reflector adjustor being at least
partially disposed in said cavity.

10. The module according to claim 9, wherein said reflector holders are
2 disposed symmetrically about a central plane which bisects said module and passes
through said bulb holder.

11. The module according to claim 9, further comprising a stationary reflector
2 holder supported by said housing.

12. The module according to claim 9, wherein said housing includes an
2 electrical connector.

13. The module according to claim 12, further comprising an electrical
2 conductor interconnecting said electrical connector with said bulb holder.

14. The module according to claim 9, further comprising a ballast connector
2 for connecting a ballast to said module.

15. The module according to claim 9, wherein said geared reflector adjustor
2 comprises an adjustment knob for adjusting the rotational position of at least one of said
reflector holders.

16. The module according to claim 9, wherein said plurality of reflector
2 holders comprises at least a first and a second reflector holder, said reflector adjustor
comprising a first adjustment gear mounted to said first reflector holder, a second
4 reflector gear mounted to said second reflector holder, and an intermediate gear engaging
said first and said second reflector gears for coordinating their rotational movement.

17. A modular luminaire comprising:
2 an elongated luminaire shell having a first end and a second end;
a first module comprising;
4 a housing having a cavity defined therein and a slot configured to engage one of
said ends of said luminaire shell;
6 at least one bulb holder supported by said housing;
a plurality of rotatably adjustable reflector holders supported by said housing; and
8 at least one geared reflector adjustor for adjusting the rotational position of at
least one of said plurality of reflector holders, said reflector adjustor being at least
10 partially disposed in said cavity;
a second module comprising;
12 a housing having a slot configured to engage one of said ends of said luminaire
shell;
14 at least one bulb holder supported by said housing; and
a plurality of rotatably adjustable reflector holders supported by said housing;
16 a plurality of elongated reflectors each having first ends and second ends;
said first module being attached to said first end of said shell with said first end of
18 said shell being disposed in said slot in said housing in said first module;

- 40 -

said second module being attached to said second end of said shell with said
20 second end of said shell being disposed in said slot in said housing in said second
module; and

22 said reflectors each having their first ends attached to one of said reflector holders
on said first module and their second ends attached to one of said reflector holders on
24 said second module;

whereby a luminaire assembly is formed.

18. A luminaire comprising:

2 a housing;

at least one bulb connector disposed in said housing;

4 at least one adjustable reflector for reflecting illumination from a bulb
interconnected with the bulb holder;

6 an adjuster drive operable to adjust the position of the adjustable reflector; and

a remote control system operable to remotely control said actuator drive so that
8 the position of the reflector may be controlled from a remote location.

19. A luminaire module comprising:

2 a housing having a cavity defined therein;

at least one bulb holder supported by said housing;

4 at least one rotatably adjustable reflector holder supported by said housing, said
holder being configured to engage an end of an elongated reflector;

6 an adjuster drive operable to adjust the rotatable position of the reflector holder;

and

8 a remote control system operable to control said adjuster drive such that the
position of the reflector holder may be controlled from a remote position.

20. A remote control illumination system comprising:
2 a luminaire having at least one movable component;
an adjuster drive operable to move said movable component to a plurality of
4 positions; and
a remote control system operable to control said adjuster drive so as to selectively
6 move said movable component to one of said plurality of positions.

21. The remote control illumination system according to claim 20, wherein
2 said remote control system includes a central processing unit operable to control said
adjuster drive.

22. The remote control illumination system according to claim 21, further
2 comprising a photo sensor in communication with said central processing unit.

23. The remote control illumination system according to claim 20, further
2 comprising a dimmable ballast, said remote control system operable to control said
dimmable ballast.

24. The remote control illumination system according to claim 20, wherein
2 said remote control system comprises a wireless control system comprising a wireless

control device and a central processing unit operable to wirelessly communicate with said

4 control device and to control said adjustor drive.

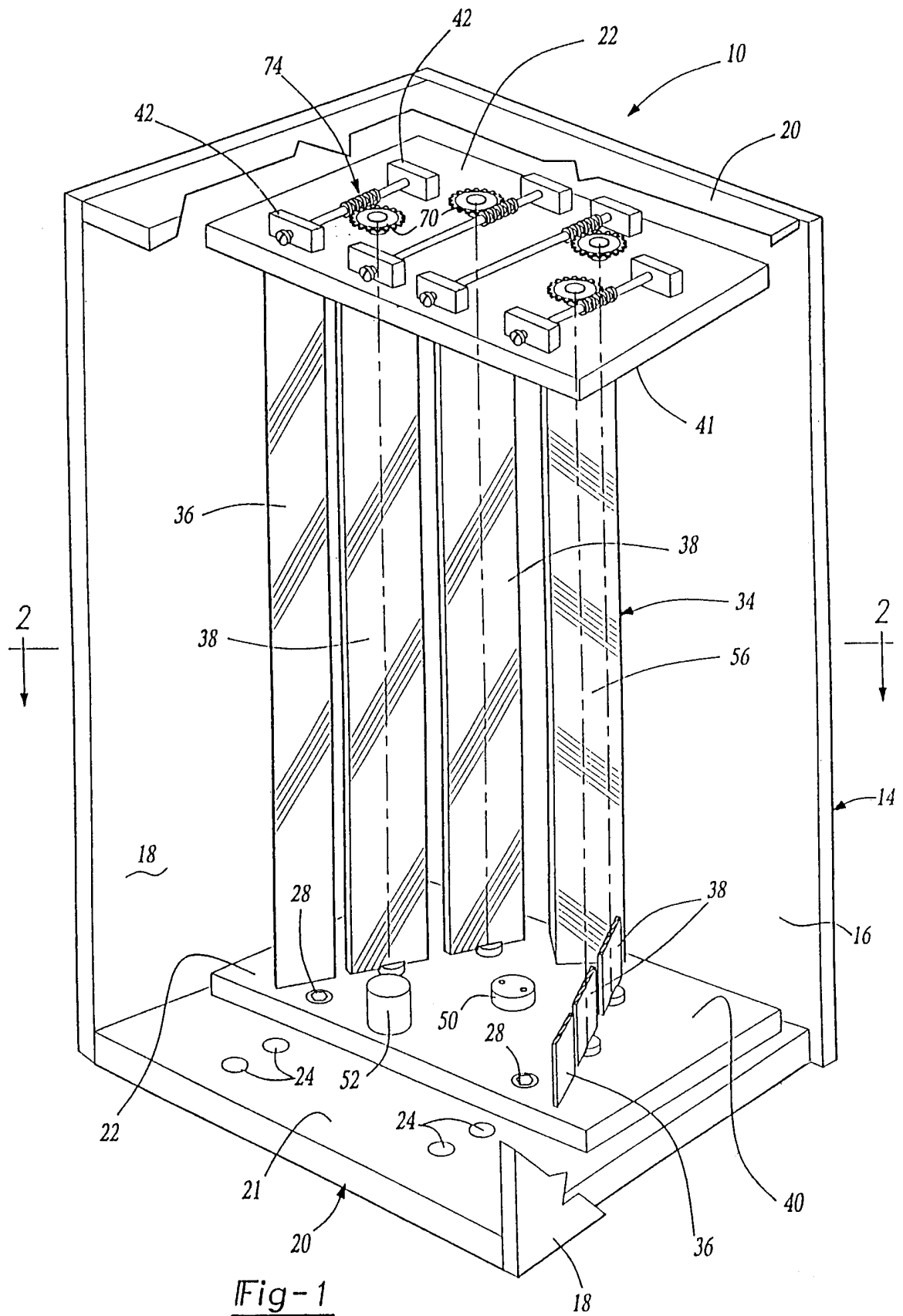

Fig-1

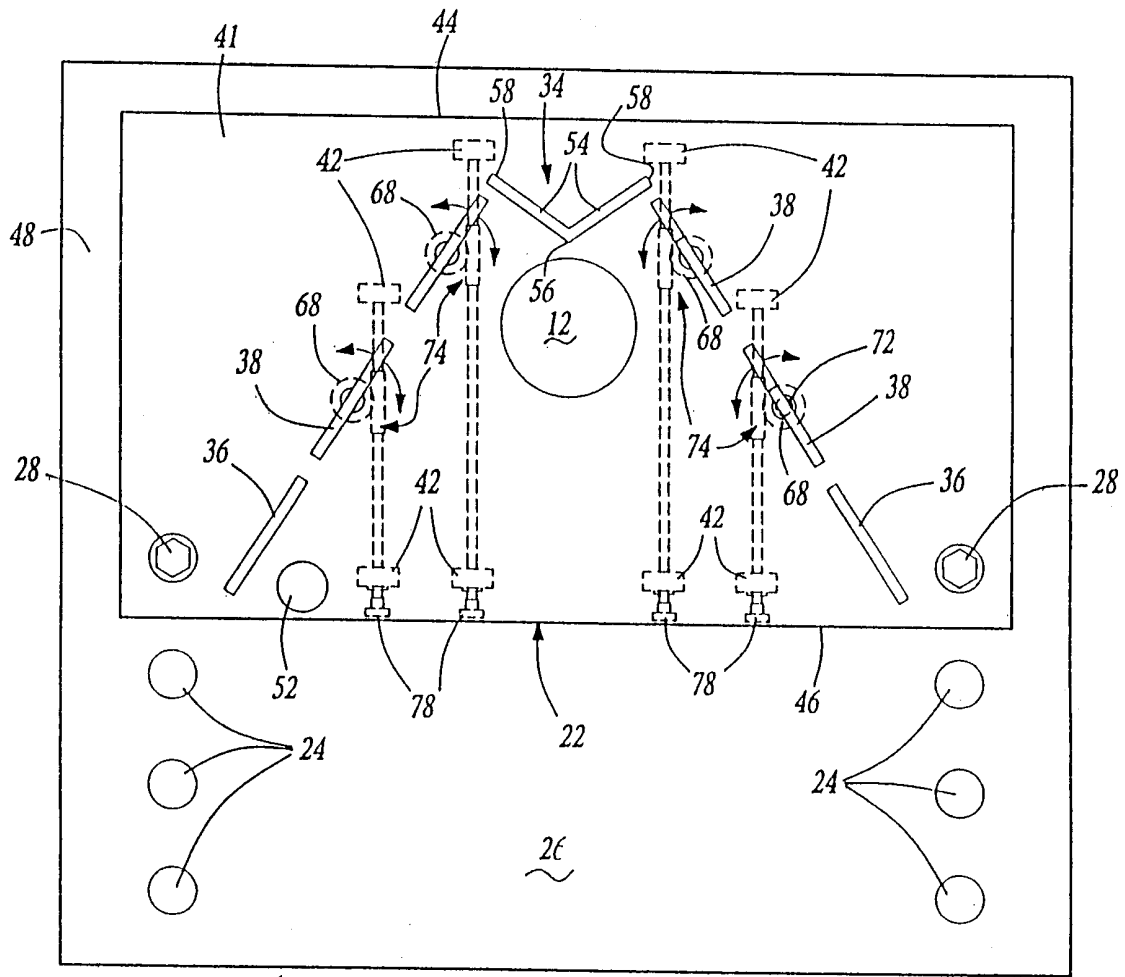

Fig-2

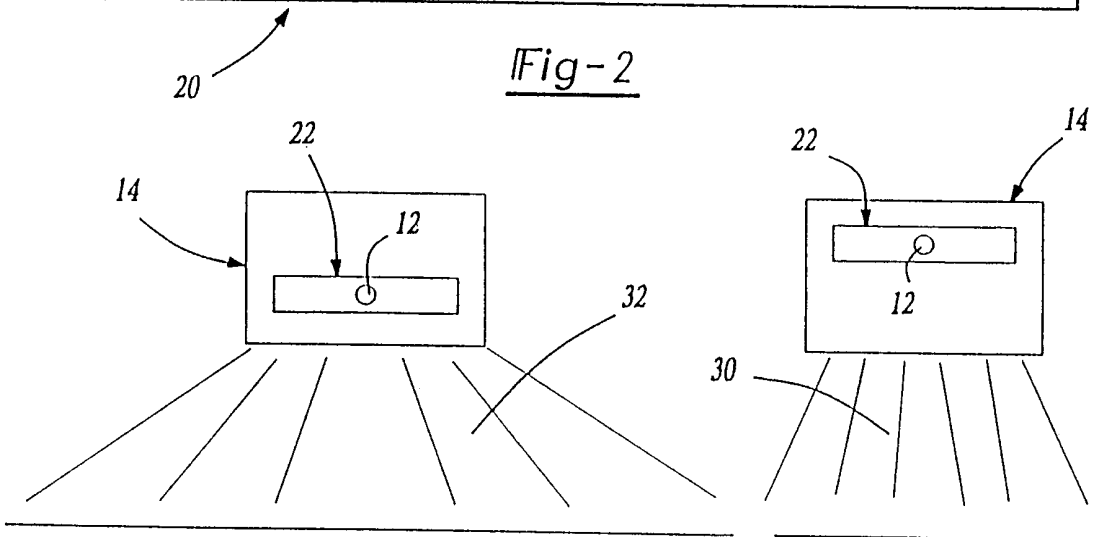
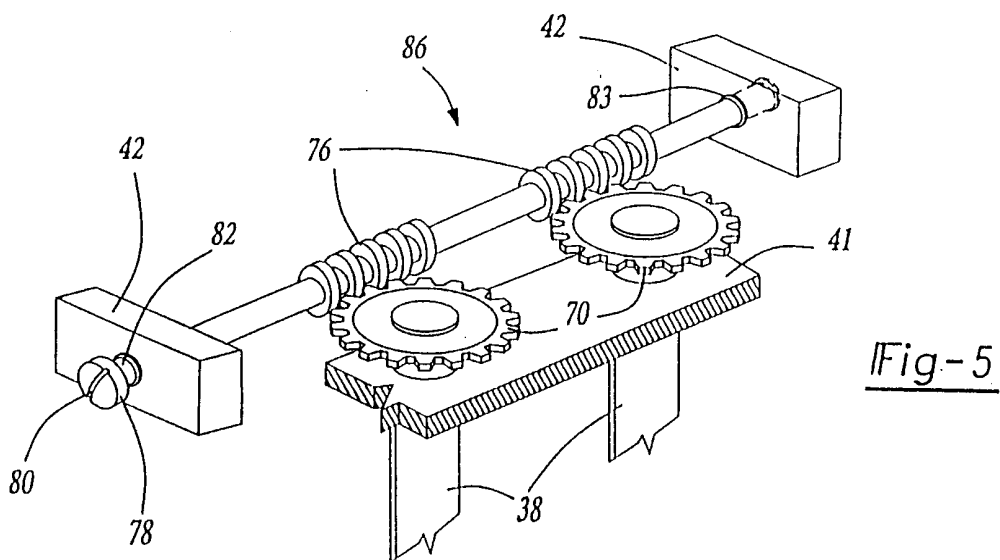
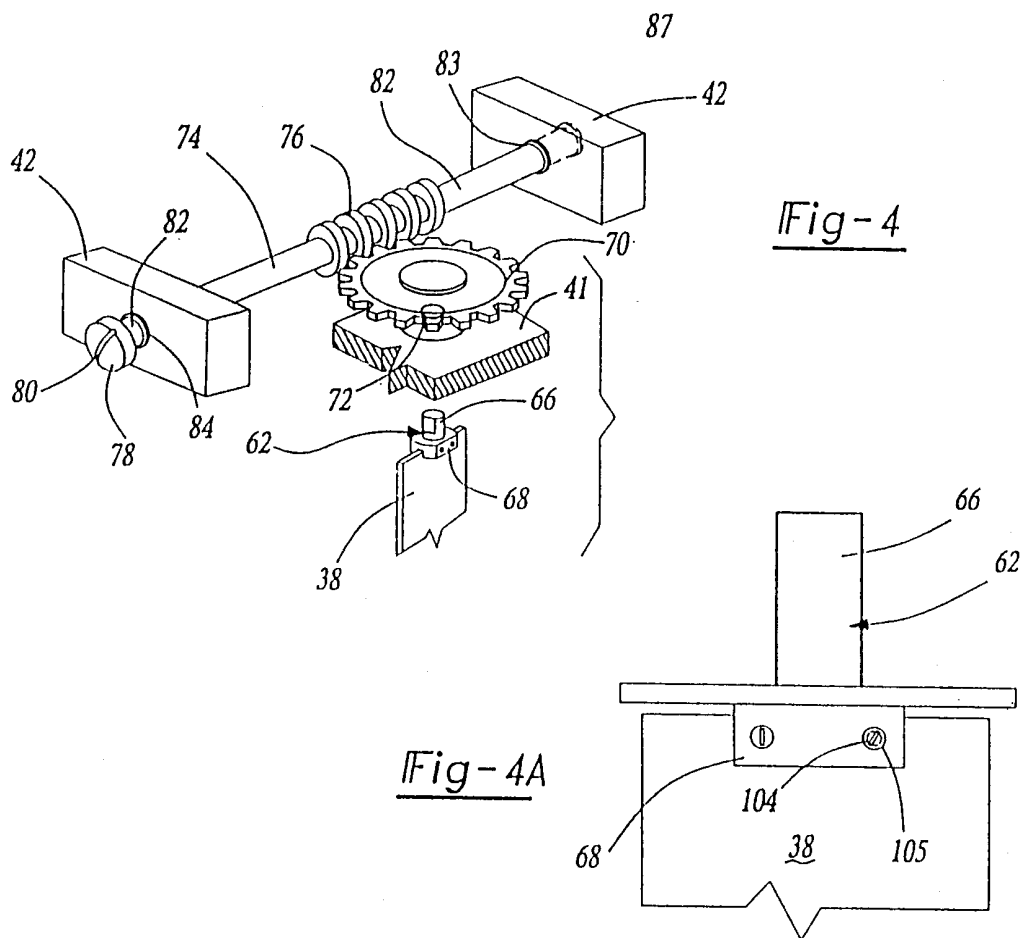
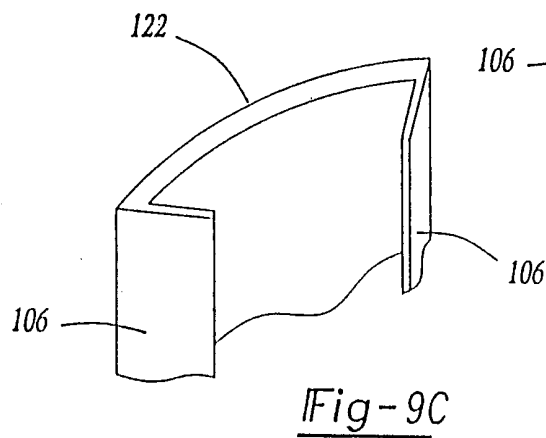
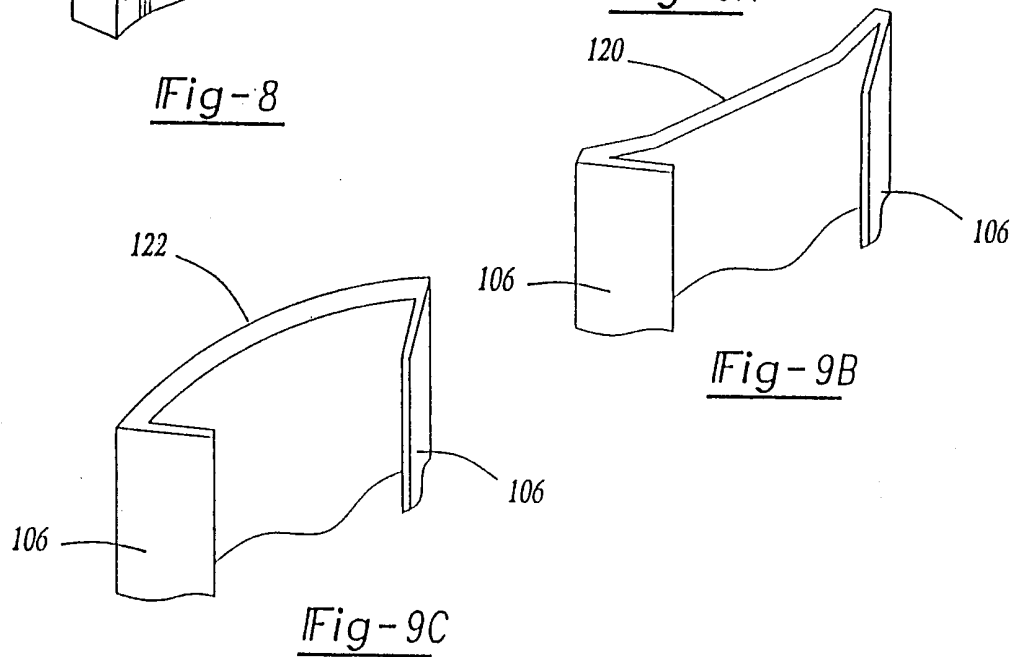
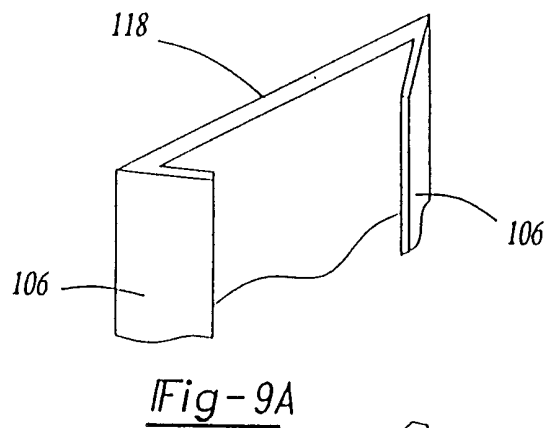
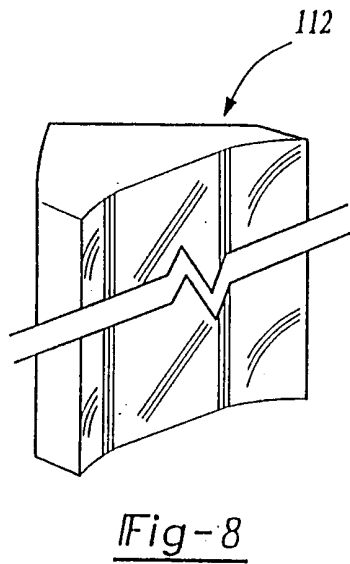
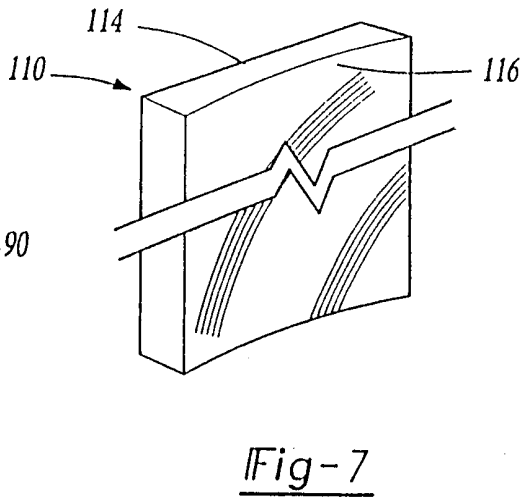
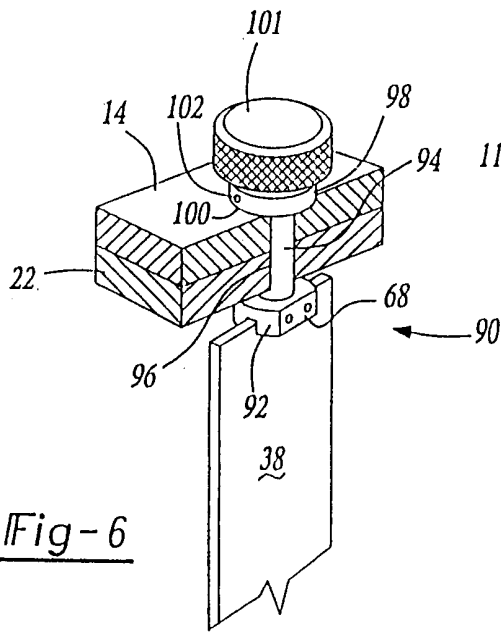

Fig-3A

Fig-3B





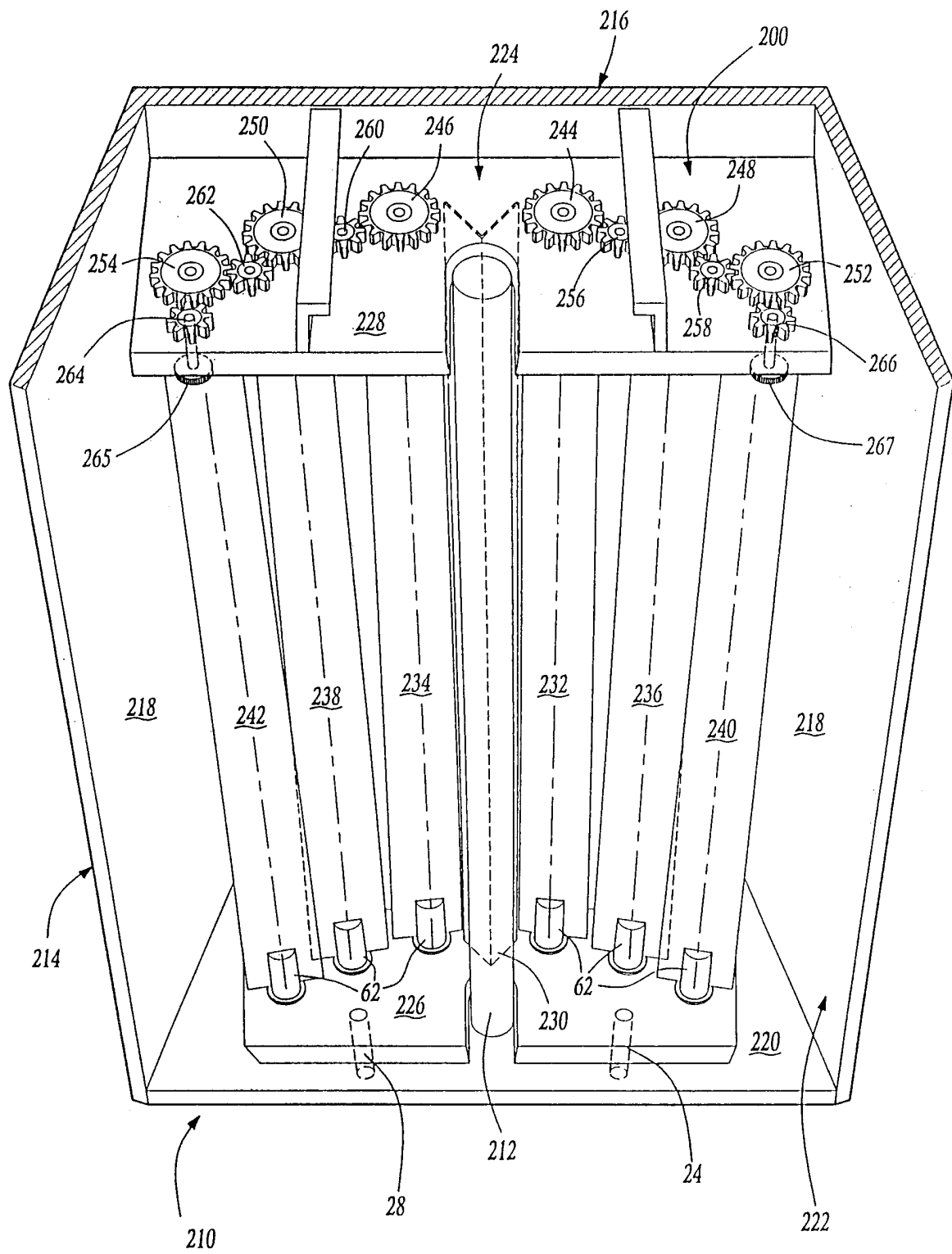

Fig-10

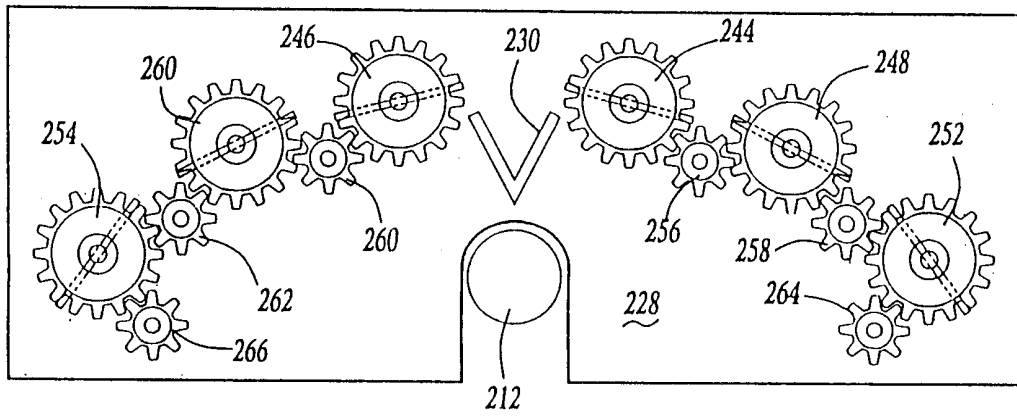

Fig-11

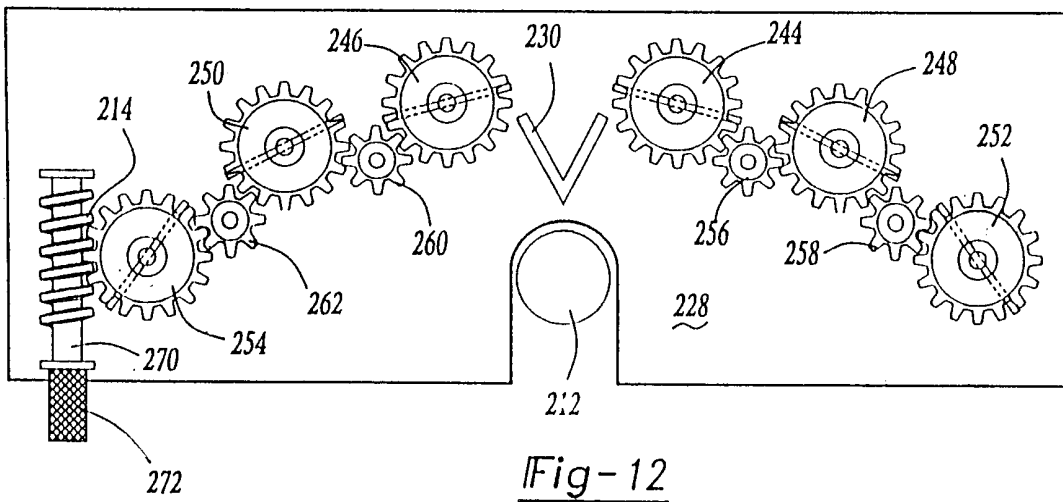

Fig-12

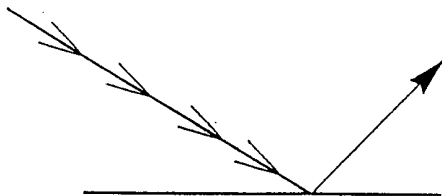

Fig-13

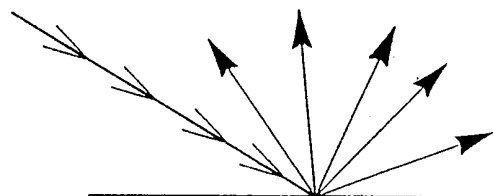

Fig-14

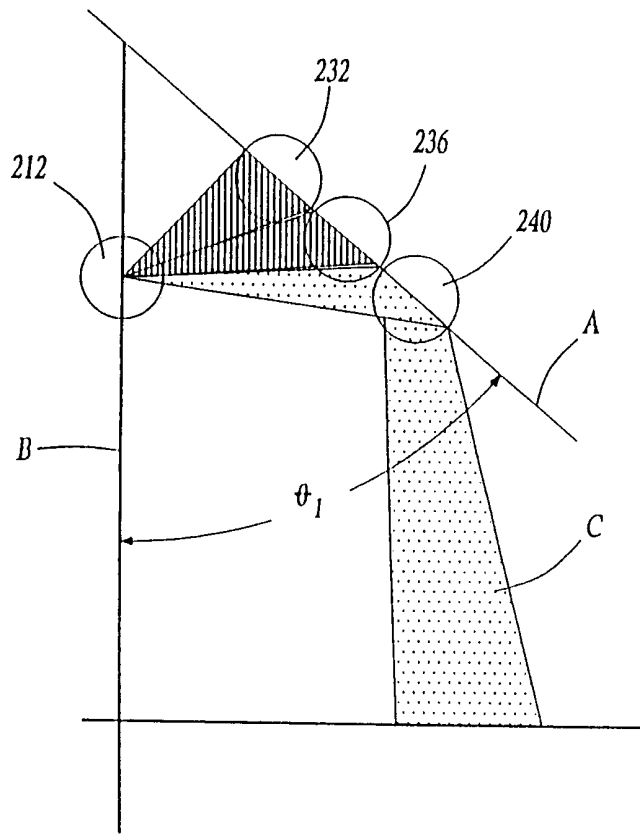

Fig-15

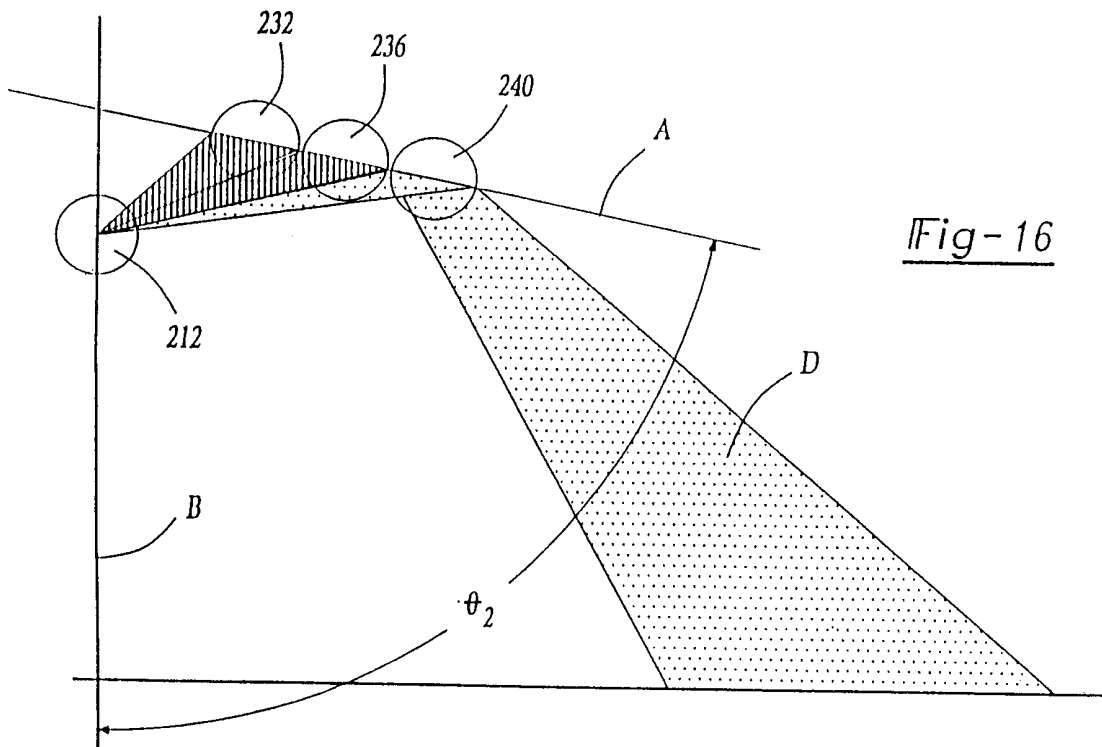

Fig-16

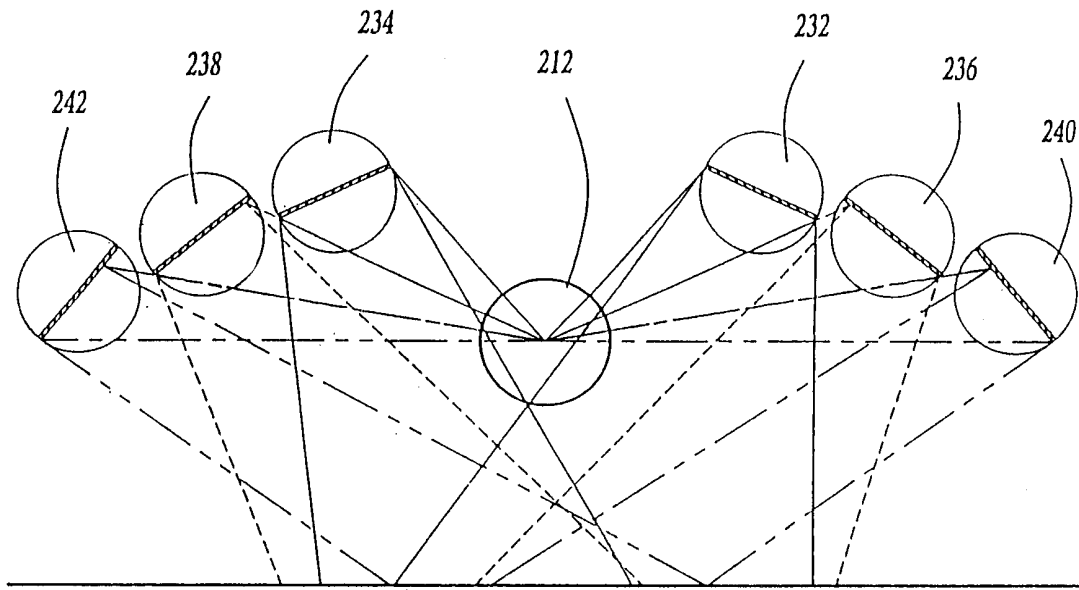

Fig-17

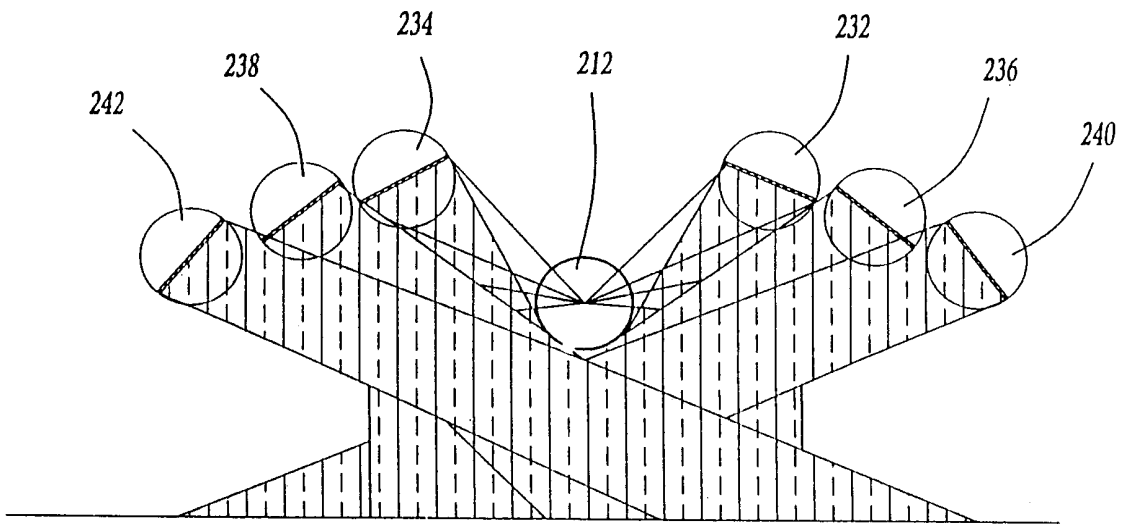

Fig-18

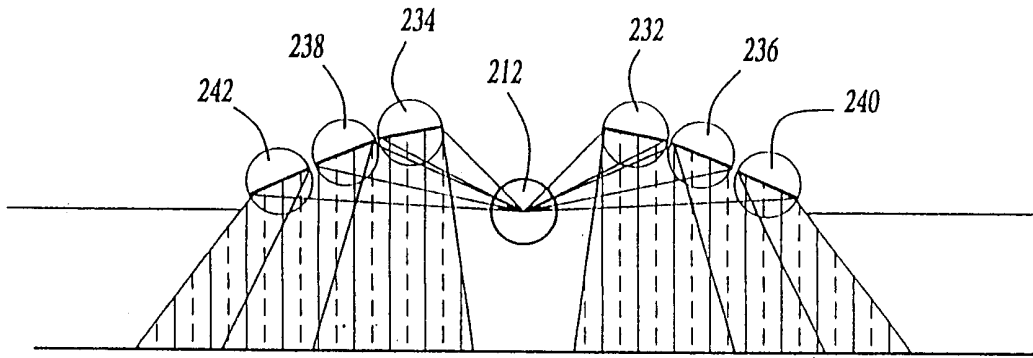

Fig-19

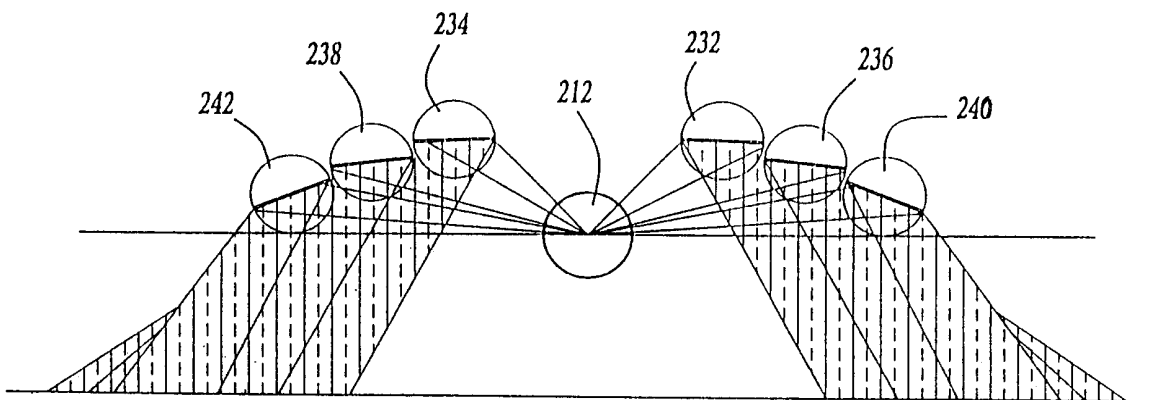

Fig-20

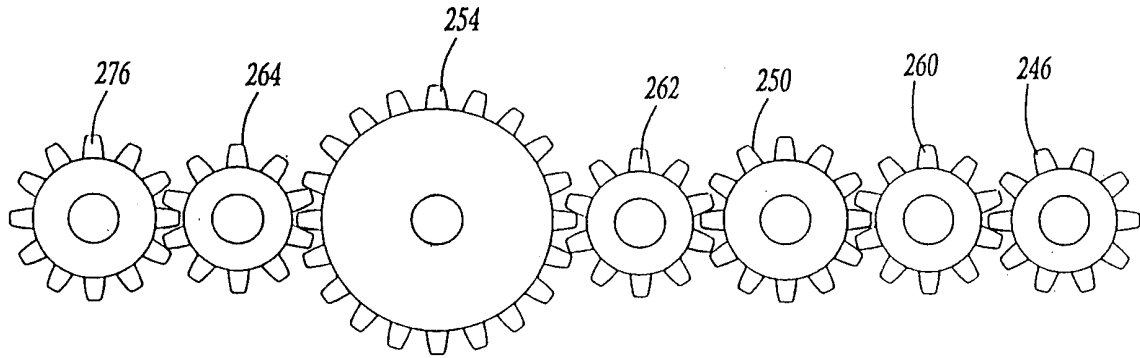

Fig-21

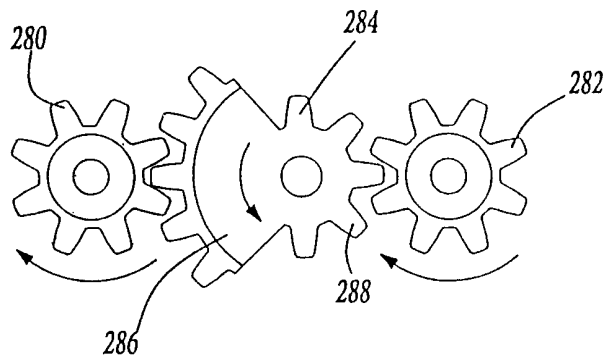

Fig-22

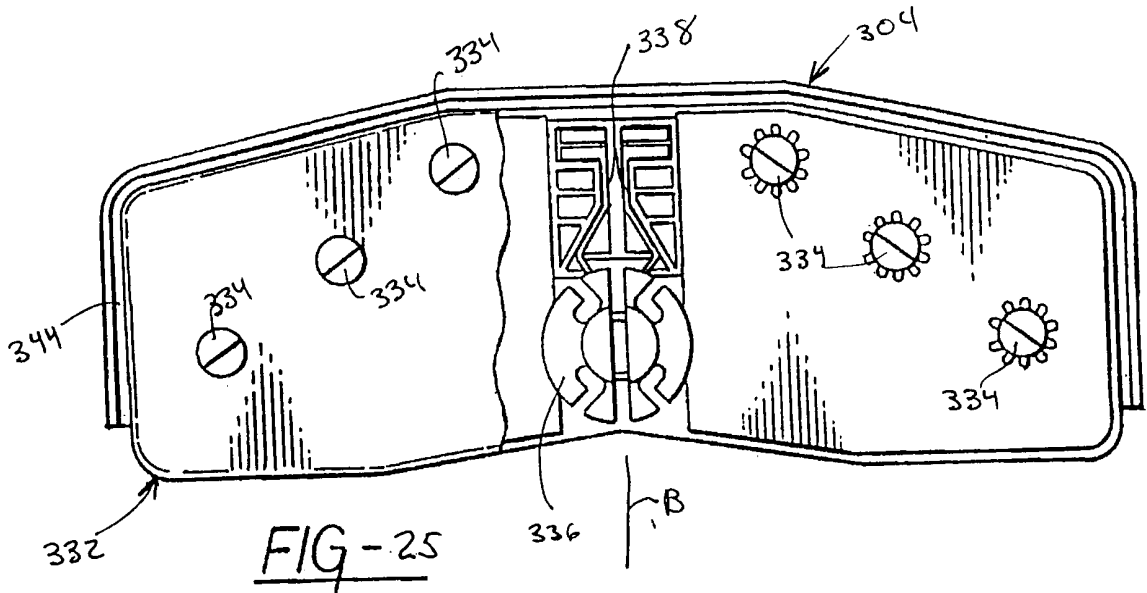
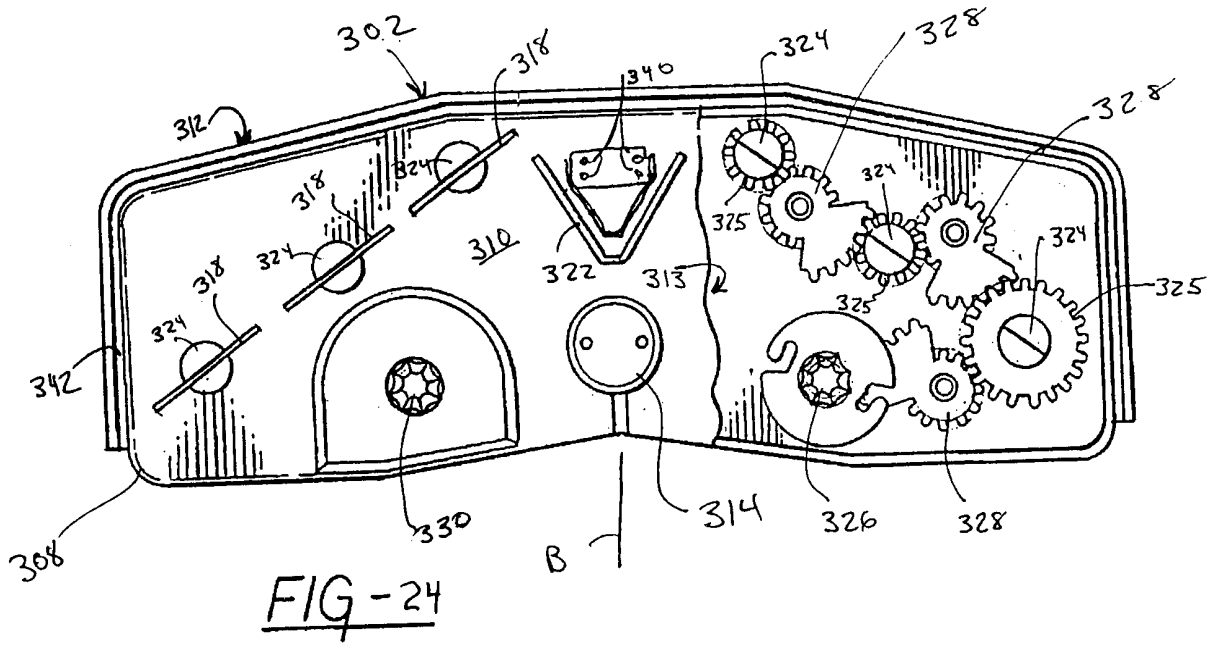

Fig. 27

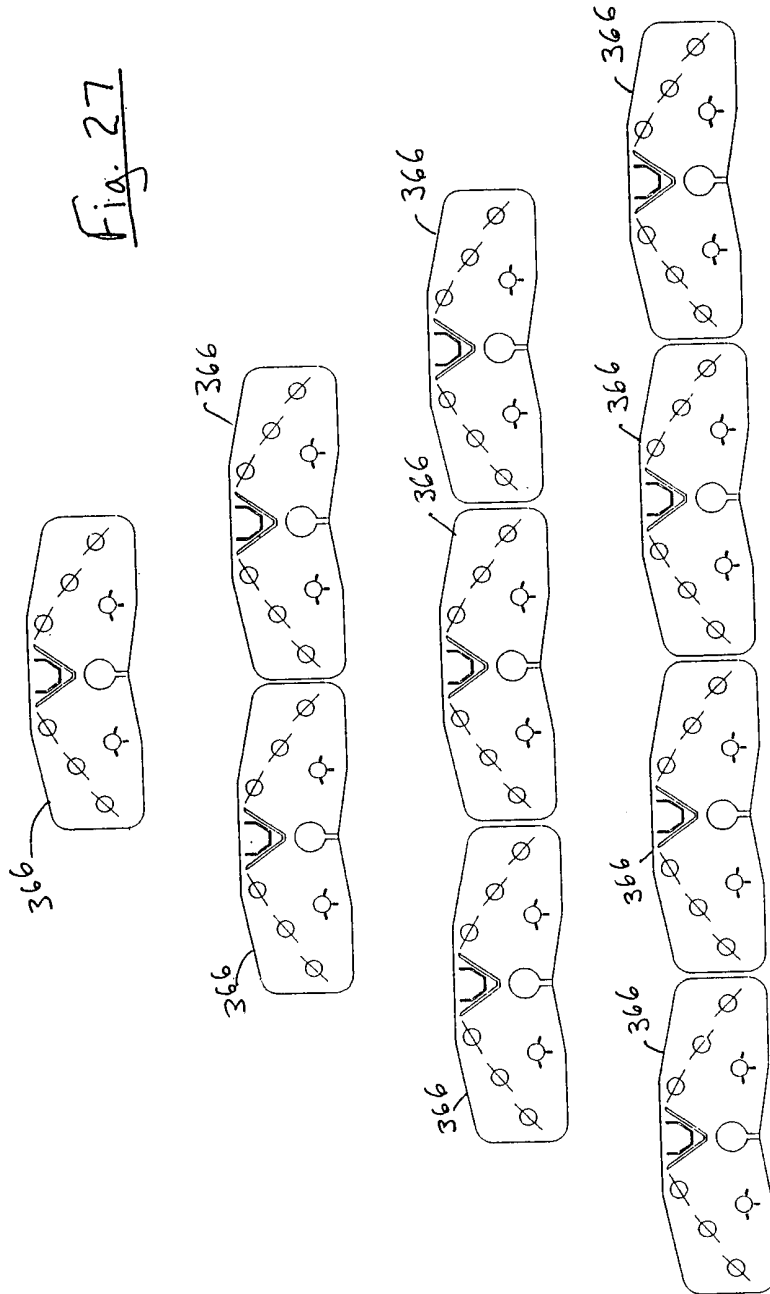
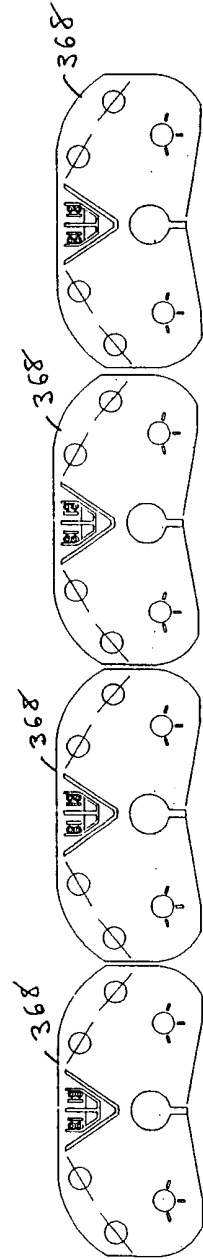
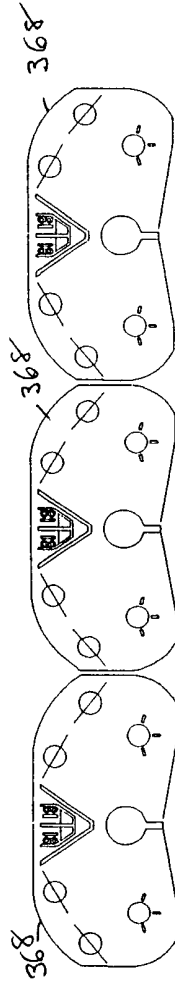
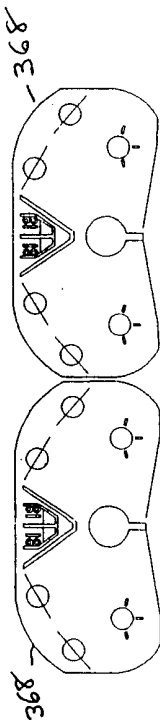
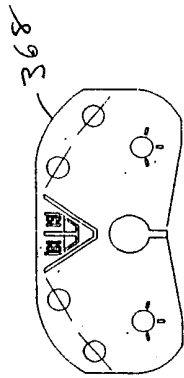

Fig. 28



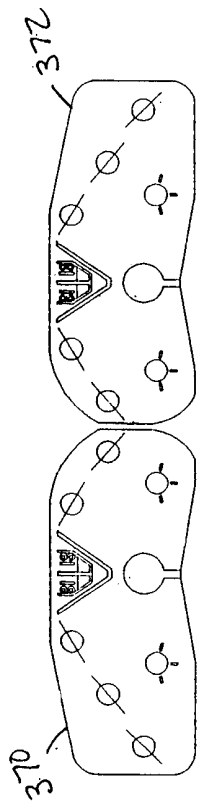
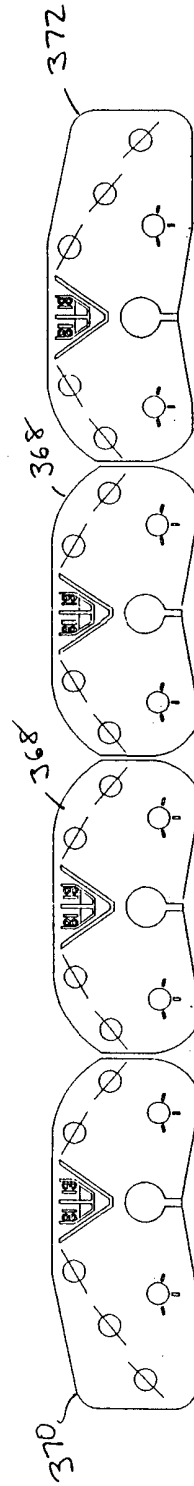
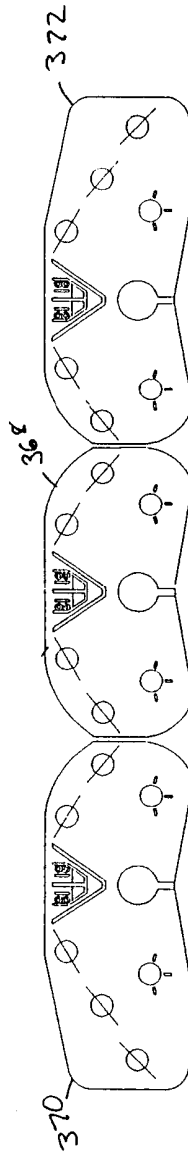

Fig. 29



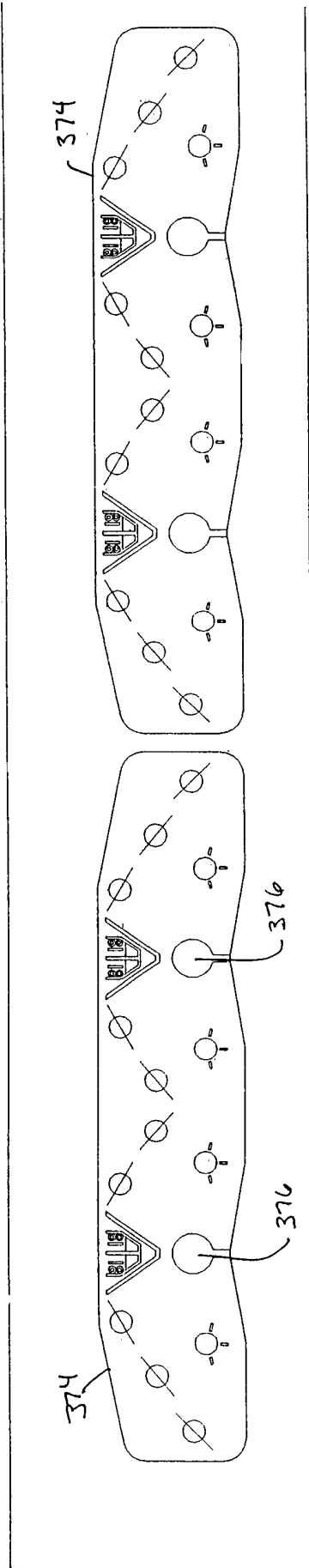

Fig 30

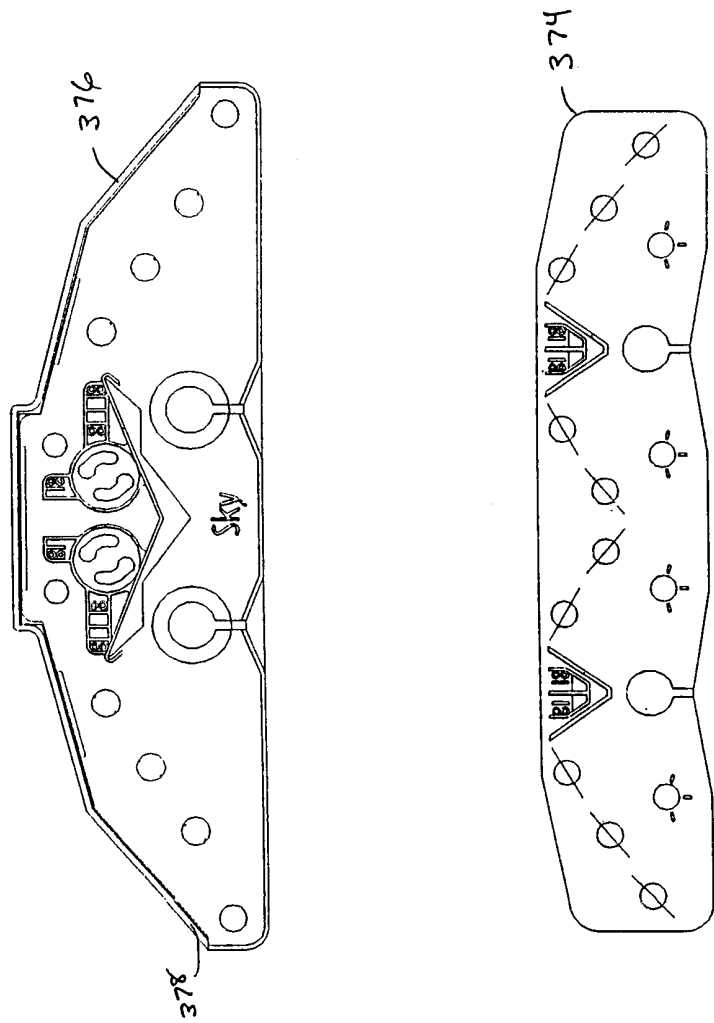

Fig. 31

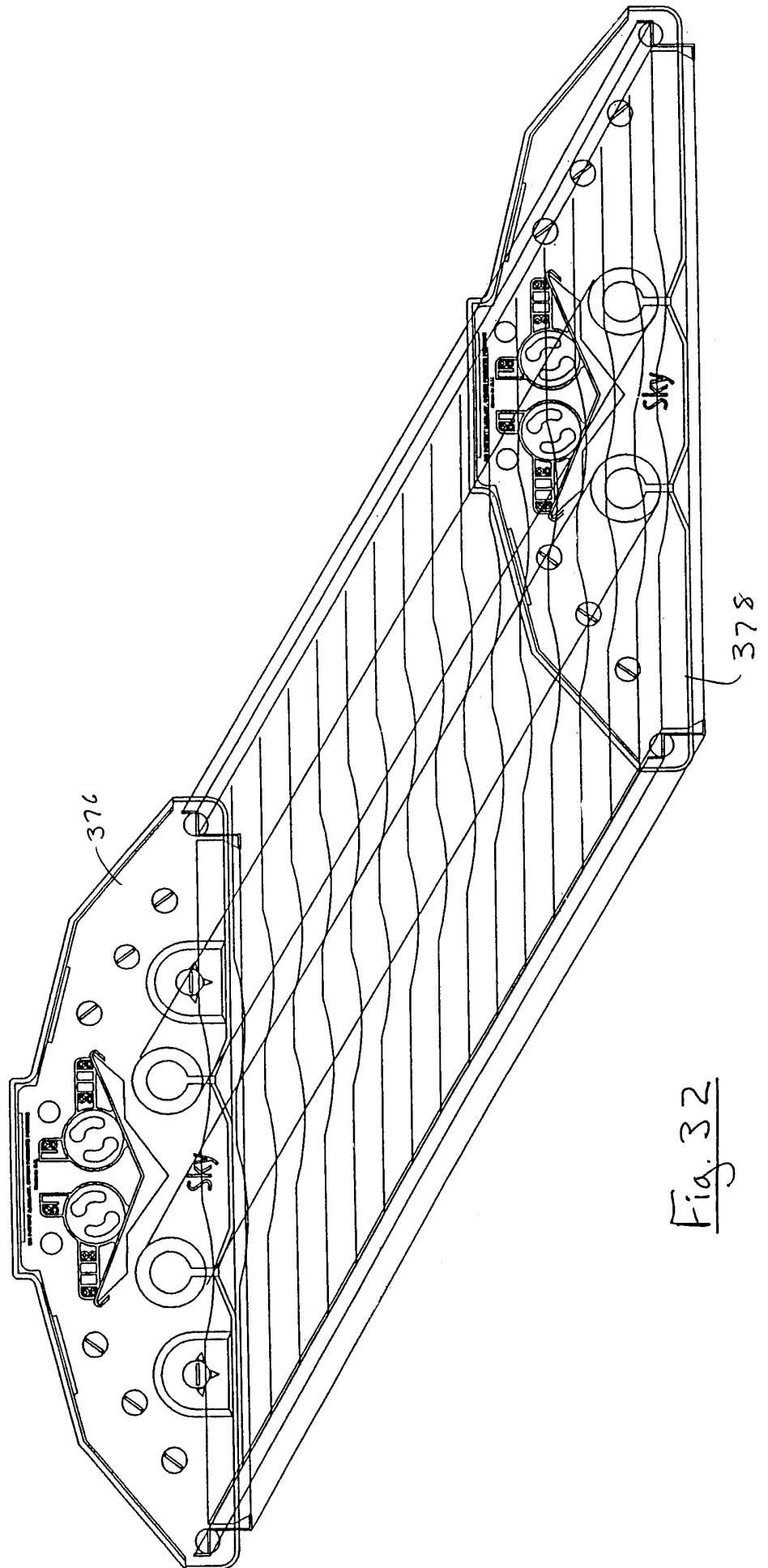

Fig. 32

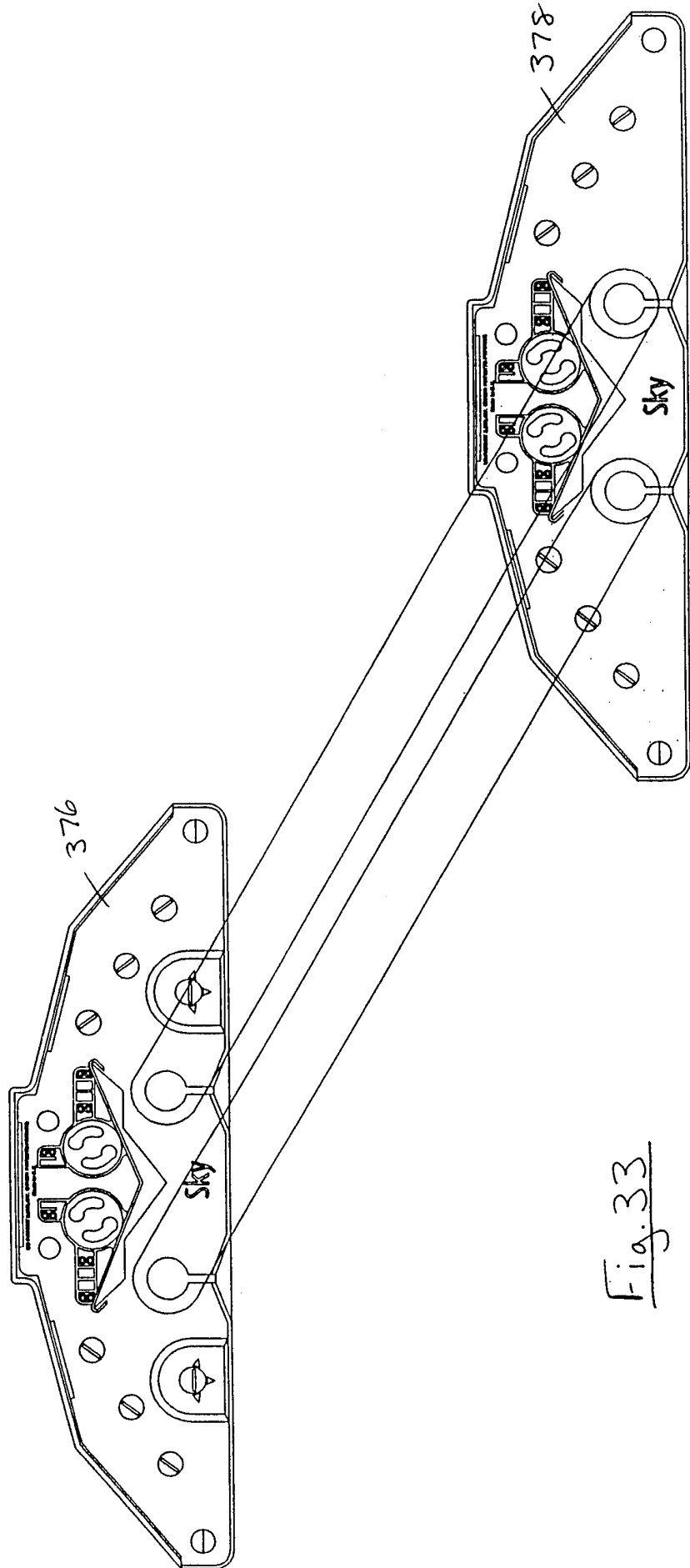

Fig. 33

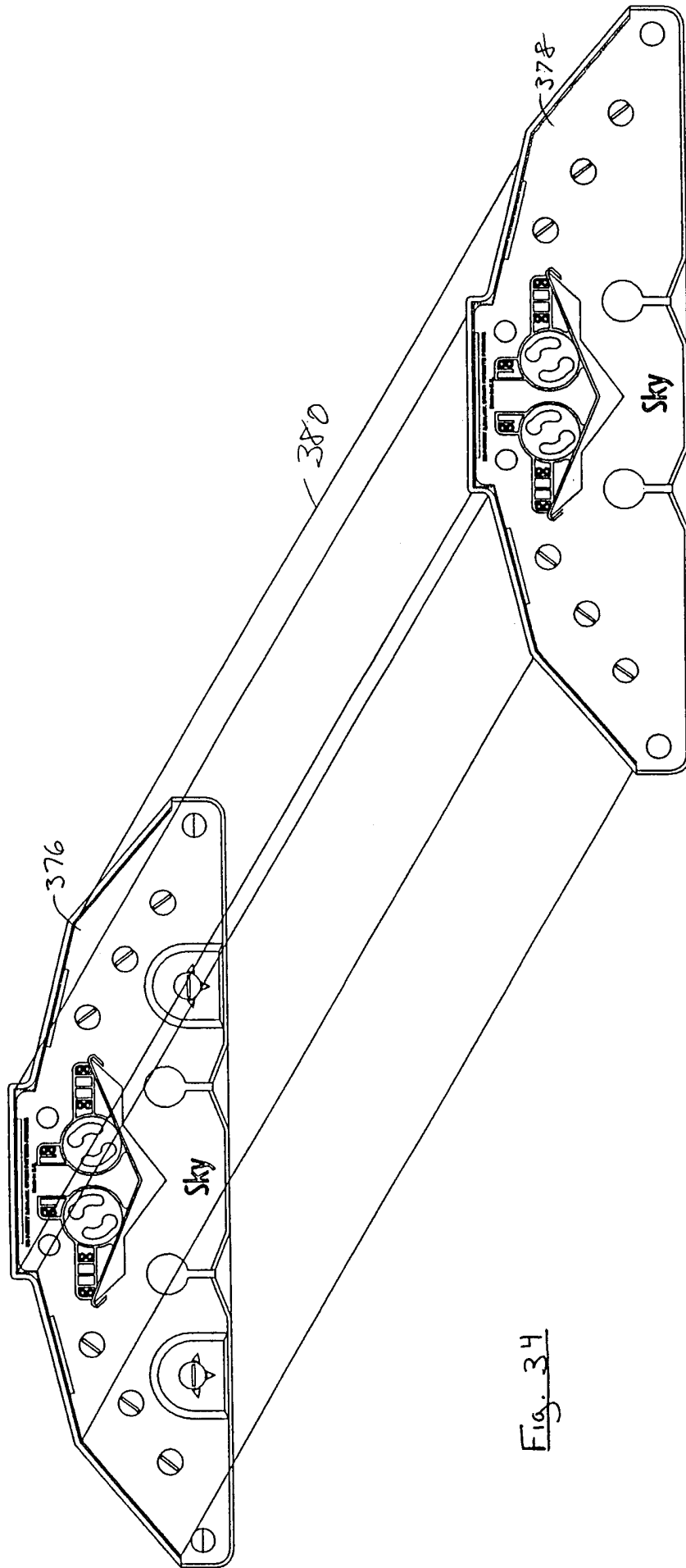
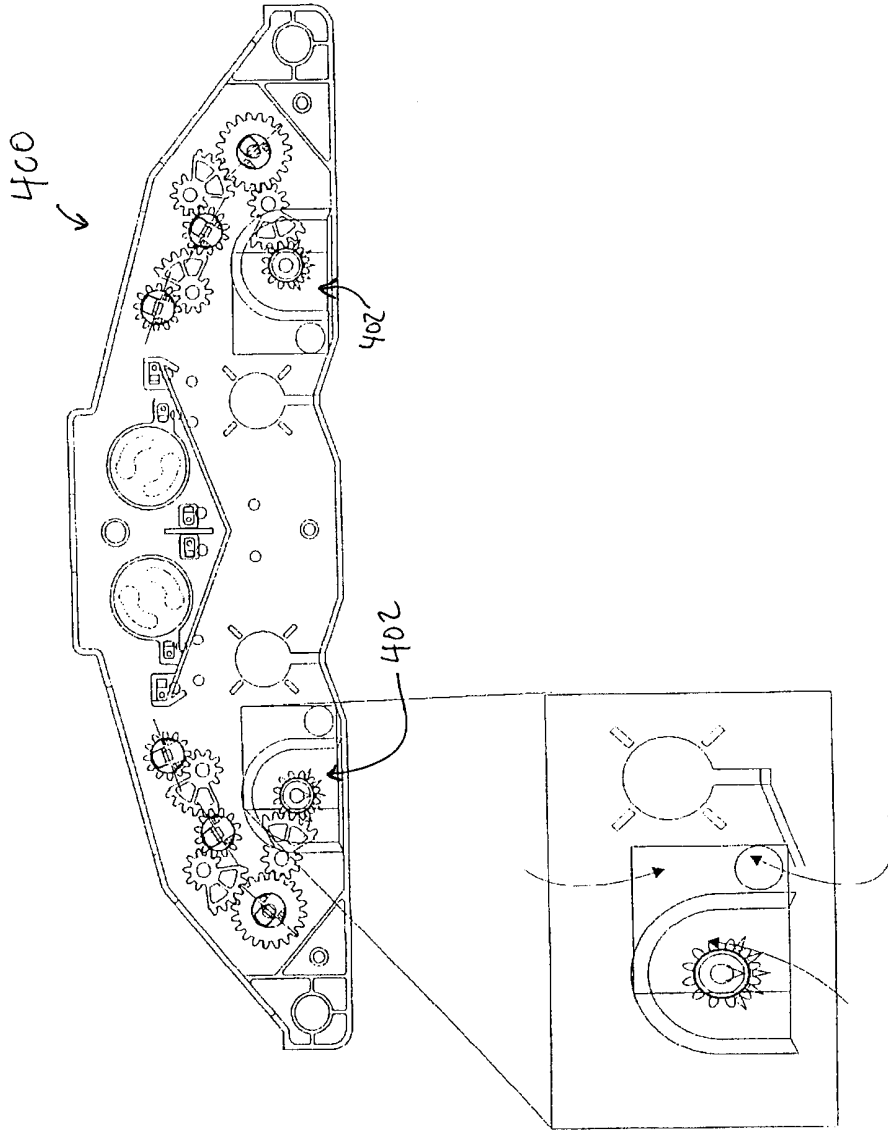

Fig. 34

Figure 35



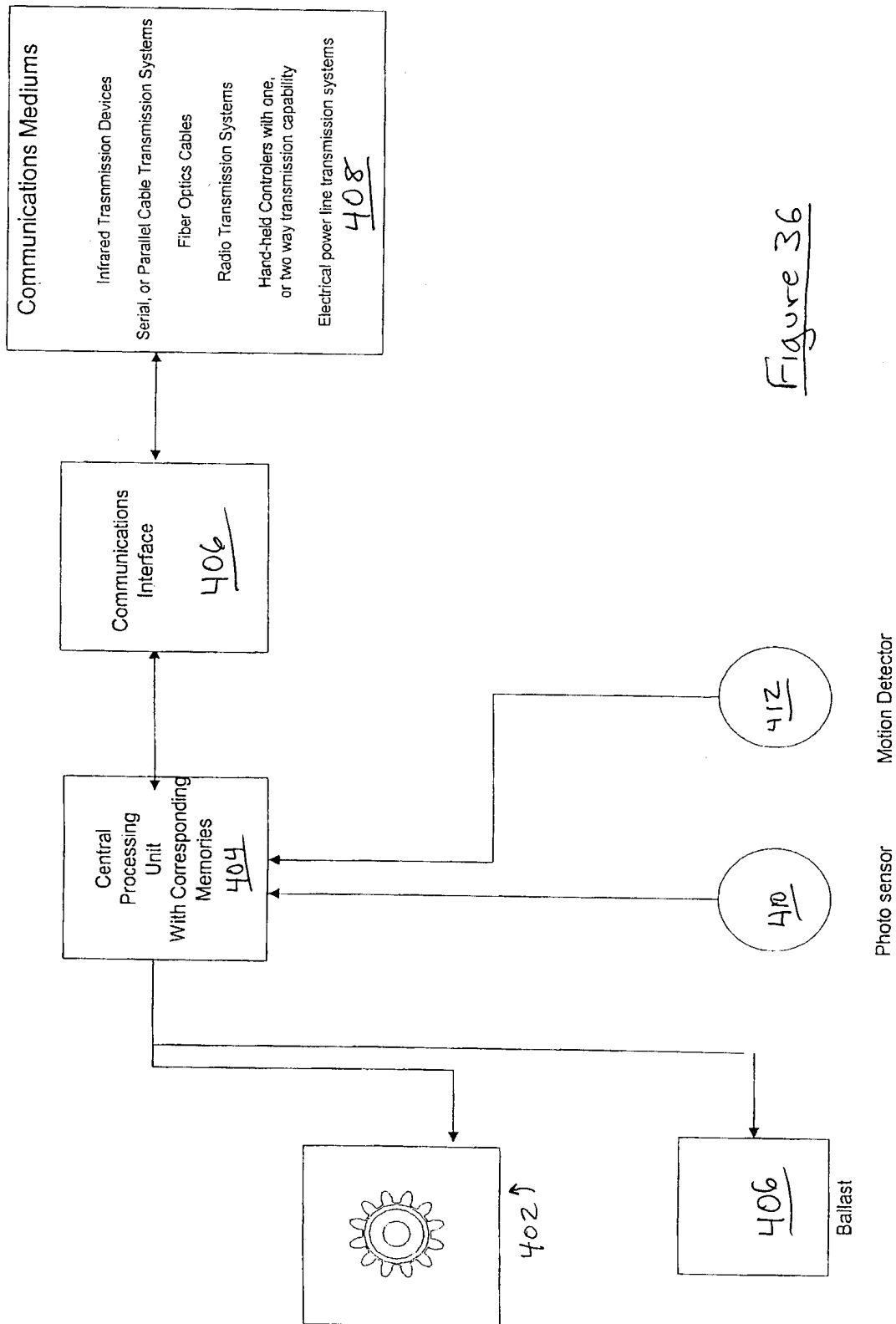

Figure 36

INTERNATIONAL SEARCH REPORT

International application No.

PCT/US00/40760

A. CLASSIFICATION OF SUBJECT MATTER

IPC(7) : F21V 14/04
 US CL : 362/283

According to International Patent Classification (IPC) or to both national classification and IPC

B. FIELDS SEARCHED

Minimum documentation searched (classification system followed by classification symbols)
 U.S. : 362/283, 235,236,237,241,217,225,277,279,282,296,297,310

Documentation searched other than minimum documentation to the extent that such documents are included in the fields searched

Electronic data base consulted during the international search (name of data base and, where practicable, search terms used)

C. DOCUMENTS CONSIDERED TO BE RELEVANT

Category *	Citation of document, with indication, where appropriate, of the relevant passages	Relevant to claim No.
A	US 5,816,691 A (GORDIN et al.) 06 October 1998 (06.10.1998)	1-24
A	US 4,872,098 A (ROMANO, 03 October 1989 (03.10.1989)	1-24
A	US 1,421,838 A (SCHAEFFER) 04 July 1922 (04.07.1922)	1-24

Further documents are listed in the continuation of Box C.

See patent family annex.

* Special categories of cited documents:		
"A"	document defining the general state of the art which is not considered to be of particular relevance	"T" later document published after the international filing date or priority date and not in conflict with the application but cited to understand the principle or theory underlying the invention
"E"	earlier application or patent published on or after the international filing date	"X" document of particular relevance; the claimed invention cannot be considered novel or cannot be considered to involve an inventive step when the document is taken alone
"L"	document which may throw doubts on priority claim(s) or which is cited to establish the publication date of another citation or other special reason (as specified)	"Y" document of particular relevance; the claimed invention cannot be considered to involve an inventive step when the document is combined with one or more other such documents, such combination being obvious to a person skilled in the art
"O"	document referring to an oral disclosure, use, exhibition or other means	
"P"	document published prior to the international filing date but later than the priority date claimed	"&" document member of the same patent family

Date of the actual completion of the international search

01 December 2000 (01.12.2000)

Date of mailing of the international search report

08 JAN 2001

Name and mailing address of the ISA/US

Commissioner of Patents and Trademarks
 Box PCT
 Washington, D.C. 20231

Facsimile No. (703)305-3230

Authorized officer

Sandra O'Shea

Telephone No. 703-555-5555