

(19) World Intellectual Property Organization
International Bureau



(43) International Publication Date
28 February 2008 (28.02.2008)

PCT

(10) International Publication Number
WO 2008/024562 A2

- (51) International Patent Classification: **Not classified**
- (21) International Application Number: PCT/US2007/072909
- (22) International Filing Date: 6 July 2007 (06.07.2007)
- (25) Filing Language: English
- (26) Publication Language: English
- (30) Priority Data: 60/823,529 25 August 2006 (25.08.2006) US
- (71) Applicant (for all designated States except US): **BORG-WARNER INC** [US/US]; 3850 Hamlin Road, Auburn Hills, Michigan 48326 (US).
- (72) Inventors; and
- (75) Inventors/Applicants (for US only): **SIMPSON, Roger T.** [US/US]; 29 Woodlane Road, Ithaca, New York 14850 (US). **TAYLOR, Danny R.** [US/US]; 32 Upper Creek Road, Freeville, New York 13068 (US).
- (74) Agents: **WOOD, Lynda M.** et al.; BorgWarner Inc., c/o Brown & Michaels, PC, 400 M & T Bank Bldg. 118 North Tioga Street, Ithaca, NY 14850 (US).
- (81) Designated States (unless otherwise indicated, for every kind of national protection available): AE, AG, AL, AM, AT, AU, AZ, BA, BB, BG, BH, BR, BW, BY, BZ, CA, CH, CN, CO, CR, CU, CZ, DE, DK, DM, DO, DZ, EC, EE, EG, ES, FI, GB, GD, GE, GH, GM, GT, HN, HR, HU, ID, IL, IN, IS, JP, KE, KG, KM, KN, KP, KR, KZ, LA, LC, LK, LR, LS, LT, LU, LY, MA, MD, ME, MG, MK, MN, MW, MX, MY, MZ, NA, NG, NI, NO, NZ, OM, PG, PH, PL, PT, RO, RS, RU, SC, SD, SE, SG, SK, SL, SM, SV, SY, TJ, TM, TN, TR, TT, TZ, UA, UG, US, UZ, VC, VN, ZA, ZM, ZW.
- (84) Designated States (unless otherwise indicated, for every kind of regional protection available): ARIPO (BW, GH, GM, KE, LS, MW, MZ, NA, SD, SL, SZ, TZ, UG, ZM, ZW), Eurasian (AM, AZ, BY, KG, KZ, MD, RU, TJ, TM), European (AT, BE, BG, CH, CY, CZ, DE, DK, EE, ES, FI, FR, GB, GR, HU, IE, IS, IT, LT, LU, LV, MC, MT, NL, PL, PT, RO, SE, SI, SK, TR), OAPI (BF, BJ, CF, CG, CI, CM, GA, GN, GQ, GW, ML, MR, NE, SN, TD, TG).

[Continued on next page]

(54) Title: VARIABLE FORCE SOLENOID WITH INTEGRATED POSITION SENSOR

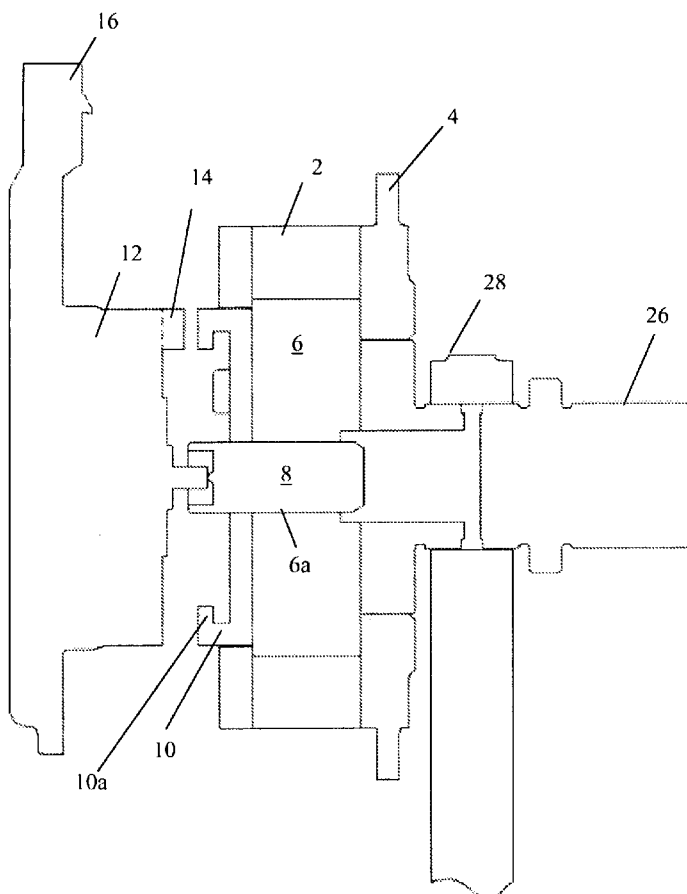

(57) Abstract: A phaser for an engine having at least one camshaft comprising a housing, a rotor, a control valve, an actuator, and a pulse wheel. The rotor connects to a camshaft coaxially located within the housing. The housing and the rotor define at least one vane separating a chamber in the housing. The vane is capable of rotation to shift the relative angular position of the housing and the rotor. The control valve is received by the rotor and directs fluid to the chambers of the phaser. The actuator positions the control valve and has at least one integrated position sensor, such that electrical connections for the actuator and the integrated position sensor are made through one connection, decreasing leakage of fluid from the phaser. A pulse wheel is mounted on the phaser for rotation therewith and in alignment with the integrated position sensor of the actuator.

WO 2008/024562 A2



Published:

- *without international search report and to be republished upon receipt of that report*

VARIABLE FORCE SOLENOID WITH INTEGRATED POSITION SENSOR

REFERENCE TO RELATED APPLICATIONS

This application claims an invention which was disclosed in Provisional Application Number 60/823,529 filed August 25, 2006, entitled "Variable Force Solenoid With Integrated Position Sensor". The benefit under 35 USC §119(e) of the United States
5 provisional application is hereby claimed, and the aforementioned application is hereby incorporated herein by reference.

BACKGROUND OF THE INVENTION

FIELD OF THE INVENTION

10 The invention pertains to the field of variable force solenoids. More particularly, the invention pertains to a variable force solenoid with an integrated position sensor.

DESCRIPTION OF RELATED ART

Modern engines have variable cam timing phasers mounted to one or more cams on the engine. These phasers can be used to change the timing of the valves or can be used
15 to vary the duration of the valves depending on the cam and lifter arrangement. One method to adjust the position of the phaser is to use a center mounted spool controlled by a variable force solenoid (VFS) and have a separate position sensor to provide feedback to the electronic controller to adjust its position. Therefore on a four cam engine, there are four connectors for the variable force solenoid and four connectors for each of the
20 associated sensors, resulting in eight locations for oil to leak out of the engine.

Therefore there is a need to reduce the leakage from the engine that occurs due to the separate connections of the position sensor and the variable force solenoid.

SUMMARY

A variable cam timing phaser for an internal combustion engine having at least one camshaft comprising a housing, a rotor, a control valve, an actuator, and a pulse wheel. The housing has an outer circumference for accepting drive force. The rotor connects to a camshaft coaxially located within the housing. The housing and the rotor define at least one vane separating a chamber in the housing. The vane is capable of rotation to shift the relative angular position of the housing and the rotor. The control valve is received by the rotor and directs fluid to the chambers of the phaser. The actuator positions the control valve and has at least one integrated position sensor, such that electrical connections for the actuator and the integrated position sensor are made through one connection, decreasing leakage of fluid from the phaser. A pulse wheel is mounted on the phaser for rotation therewith and in alignment with the integrated position sensor of the actuator.

In one embodiment, the pulse wheel is magnetic and the integrated position sensor detects the change in flux as the edge of the pulse wheel passes the sensor.

In an alternate embodiment, the pulse wheel is ferrous and the integrated position sensor contains a magnet. The integrated position sensor detects the changes in magnetic field as the edge of the pulse wheel passes the sensor.

BRIEF DESCRIPTION OF THE DRAWINGS

Fig. 1 shows a side view of a variable cam timing phaser actuated by a variable force solenoid with an integrated position sensor.

Fig. 2 shows a front view of the variable cam timing phaser.

Fig. 3 shows a front view of the connector and the variable force solenoid including the integrated position sensor.

Fig. 4 shows an alternate embodiment.

DETAILED DESCRIPTION OF THE INVENTION

Internal combustion engines have employed various mechanisms to vary the angle between the camshaft and the crankshaft for improved engine performance or reduced emissions. The majority of these variable camshaft timing (VCT) mechanism use one or more "vane phasers" on the engine camshaft 26 (or camshafts, in a multiple-camshaft engine). In most cases, the phasers have a rotor 6 with one or more vanes, mounted to the end of the camshaft 26, surrounded by a housing 2 with the vane chambers into which the vanes fit. It is possible to have the vanes mounted to the housing 2, and the chambers in the rotor 6, as well. The housing's outer circumference forms the sprocket 4, pulley or gear accepting drive force through a chain, belt, or gears, usually from the crankshaft, or possible from another camshaft in a multiple-cam engine.

The rotor 6 has a bore 6a that receives a control valve 8. The control valve 8 directs fluid flow to shift the relative angular position of the rotor 6 relative to the housing 2. The position of the control valve 8 is influenced by an actuator 12 on one end and a spring (not shown) on the opposite end. The actuator 12 as shown in Figure 1 is a variable force solenoid, although other actuators such as a stepper motor assembly with integral position sensor, or any actuator with linear motion may be used.

In prior art phasers, as discussed in the background, multiple separate position sensors provide feedback to the electronic controller regarding the position of the camshaft relative to the crankshaft and the position of the phaser. In turn the feedback is sent from the electronic controller to the variable force solenoid, which influences the position of the control valve and the phaser. The multiple position sensors of the prior art phasers require multiple connectors and connections between the position sensors and the electronic controller and the variable force solenoid.

In order to reduce the leakage that occurs in the prior art systems, the position sensor 14 of the phaser of the present invention is integrated into the variable force solenoid (VFS) 12, such that the electrical connections for the solenoid 12 and the position sensor 14 are made through one connector 16. Due to the magnetic flux and magnetic pathways associated with the variable force solenoid 12, the position sensor 16 must be isolated from such magnetic pathways of the VFS 12 as shown in Figures 1 and 3.

The position sensors 14 may be Hall sensors, magneto resistive sensors, variable reluctance sensors, or any other sensor that can sense a pulse wheel. However, through testing, Hall sensors and magneto resistive sensors perform better than the variable reluctance sensors. While only one position sensor is shown, multiple sensors may be present and may sense the position of the housing or monitoring other parts of the phaser.

In one embodiment, as shown in Figures 1 through 3, a magnetic pulse wheel 10 may be used. The pulse wheel 10 is attached to the camshaft and rotates with the phaser. The pulse wheel is positioned such that an edge 10a of the pulse wheel is aligned with the position sensor 14, integrated into the variable force solenoid 12. As the edge 10a of the pulse wheel passes by the sensor 14, the sensor may detect the change in flux and thus the position of the camshaft.

In another embodiment, the pulse wheel 10 may be ferrous and the position sensor 14 may contain a magnet, so that the position sensor can detect the changes in the magnetic field as the ferrous pulse wheel passes by.

Alternatively, a rubber ring 30 may replace the pulse wheel. The rubber ring 30 would be attached to the camshaft and rotate with the phaser. The rubber ring, as shown in Figure 4 has magnets 32 interspersed at intervals along its rubber 34 circumference, so that when the magnet 32 pass the position sensor 14, the sensor 14 would be able to detect the changes in the magnetic field as the magnets 32 in the rubber ring rotates.

Accordingly, it is to be understood that the embodiments of the invention herein described are merely illustrative of the application of the principles of the invention. Reference herein to details of the illustrated embodiments is not intended to limit the scope of the claims, which themselves recite those features regarded as essential to the invention.

What is claimed is:

- 1 1. A variable cam timing phaser for an internal combustion engine having at least one
2 camshaft comprising:
3 a housing having an outer circumference for accepting drive force;
4 a rotor for connection to a camshaft coaxially located within the housing,
5 the housing and the rotor defining at least one vane separating a
6 chamber in the housing, the vane being capable of rotation to shift
7 the relative angular position of the housing and the rotor;
8 a control valve received by the rotor for directing fluid to the chambers;
9 an actuator for positioning the control valve having at least one integrated
10 position sensor, such that electrical connections for the actuator and
11 the integrated position sensor are made through one connection,
12 decreasing leakage of fluid from the phaser
- 1 2. The variable cam timing phaser of claim 1, further comprising a pulse wheel mounted
2 on the phaser for rotation therewith and in alignment with the integrated position
3 sensor of the actuator.
- 1 3. The variable cam timing phaser of claim 2, wherein the pulse wheel is magnetic and
2 wherein when the pulse wheel passes the integrated position sensor, the sensor
3 detects changes in flux, determining the position of the camshaft.
- 1 4. The variable cam timing phaser of claim 2, wherein the pulse wheel is ferrous and the
2 integrated position sensor contains a magnet, wherein when pulse wheel passes the
3 integrated position sensor, the sensor detects changes in the magnetic field,
4 determining the position of the camshaft.
- 1 5. The variable cam timing phaser of claim 1, wherein the integrated position sensor is a
2 Hall sensor, magneto resistive sensor, or a variable reluctance sensor.

1 6. The variable cam timing phaser of claim 1, further comprising a rubber ring mounted on
2 the camshaft of the phaser for rotation therewith and has magnets interspersed at
3 intervals along its circumference.

1 7. The variable cam timing phaser of claim 6, wherein the integrated position sensor
2 contains a magnet, and wherein when the magnets of the rubber ring pass the
3 integrated position sensor, the sensor detects changes in the magnetic field,
4 determining the position of the phaser.

Fig. 1

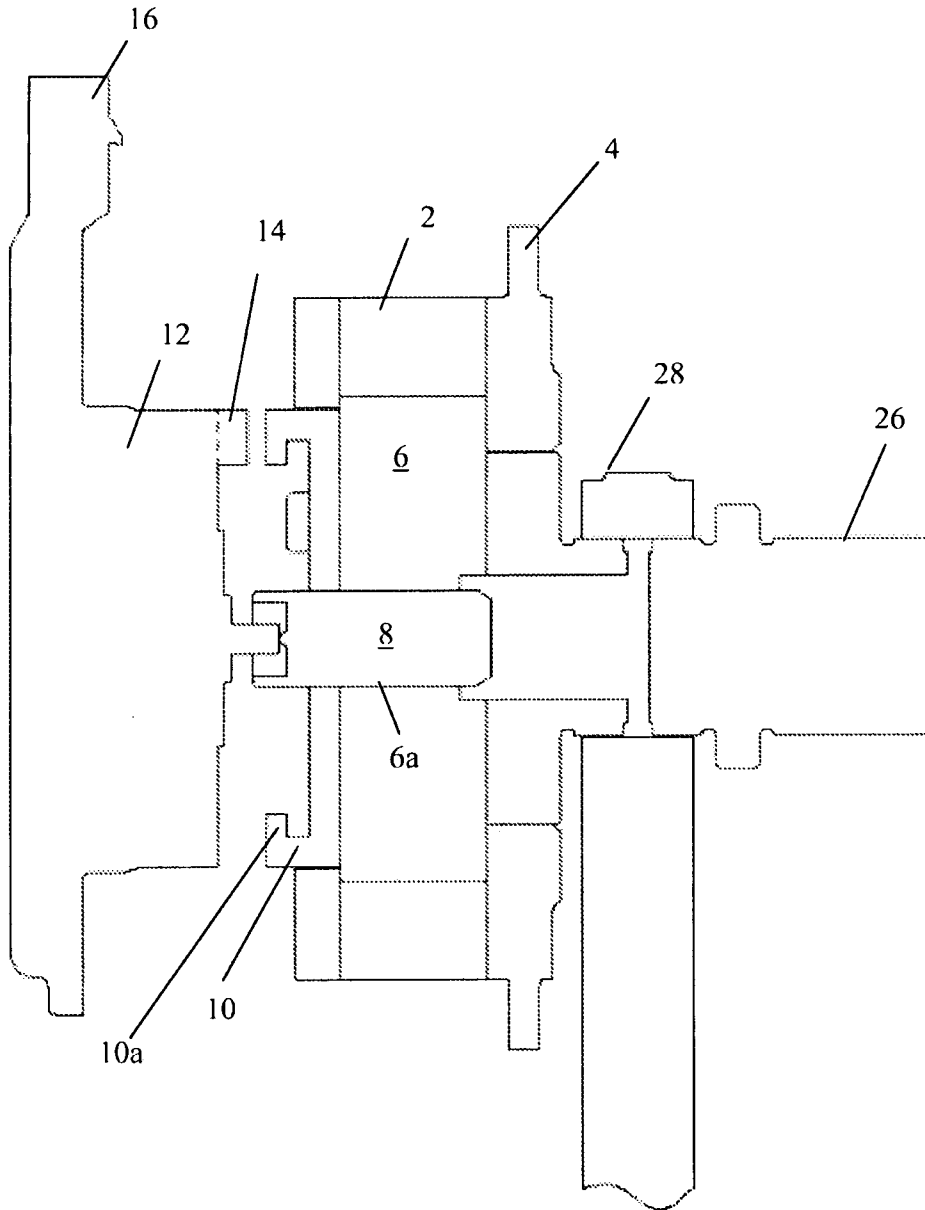

Fig. 2

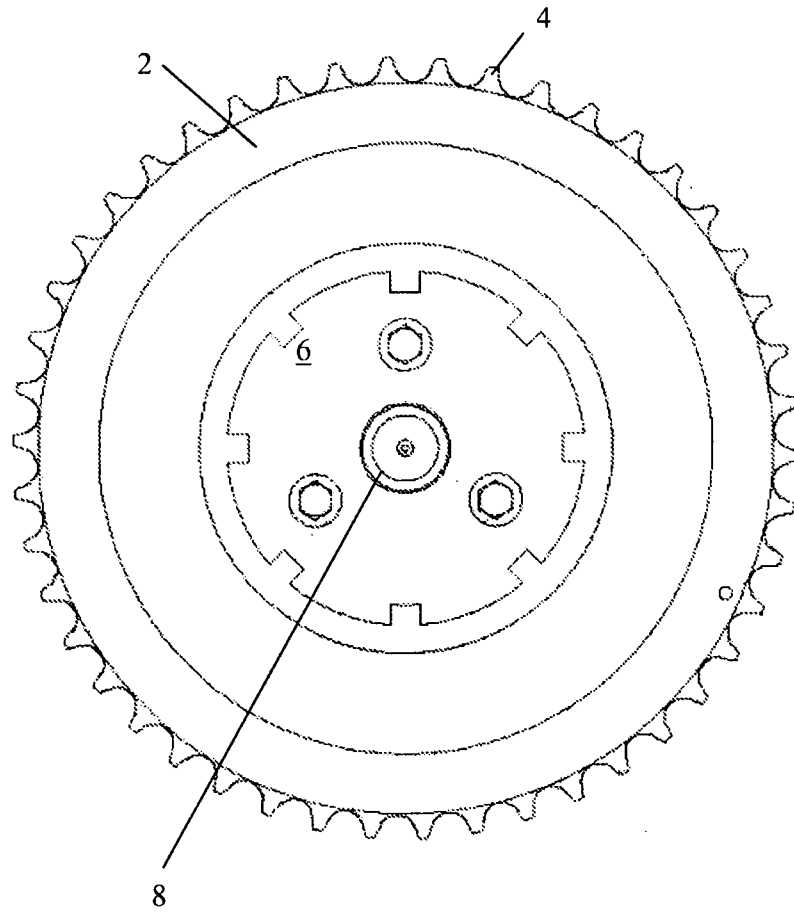

Fig. 3

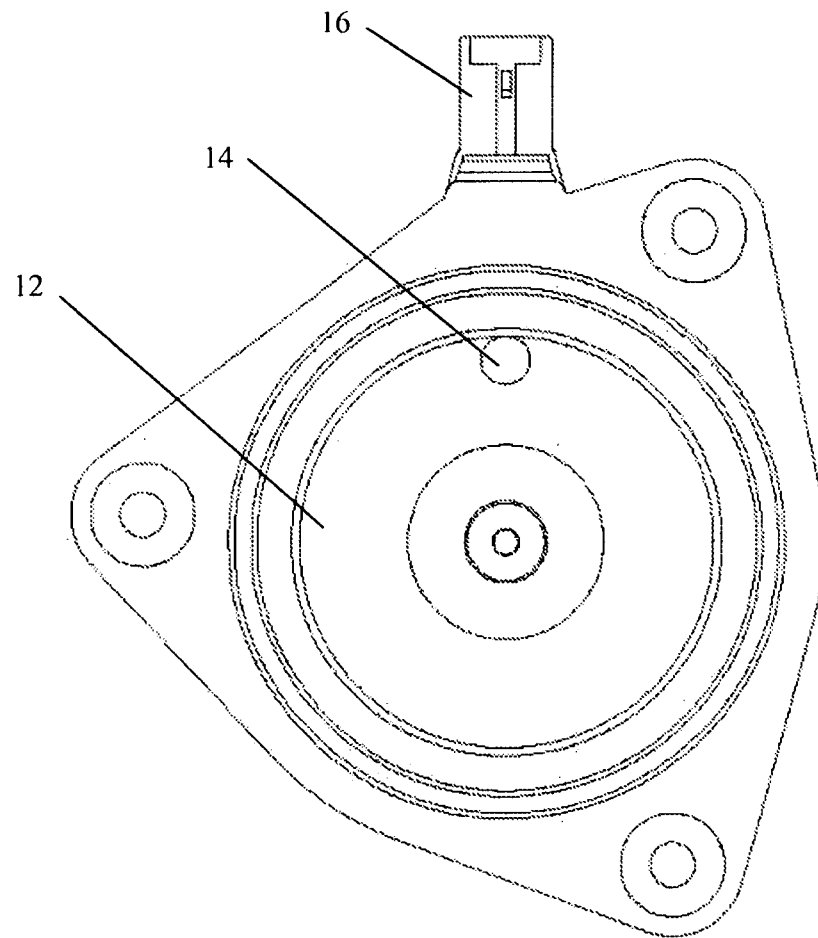

Fig. 4

