

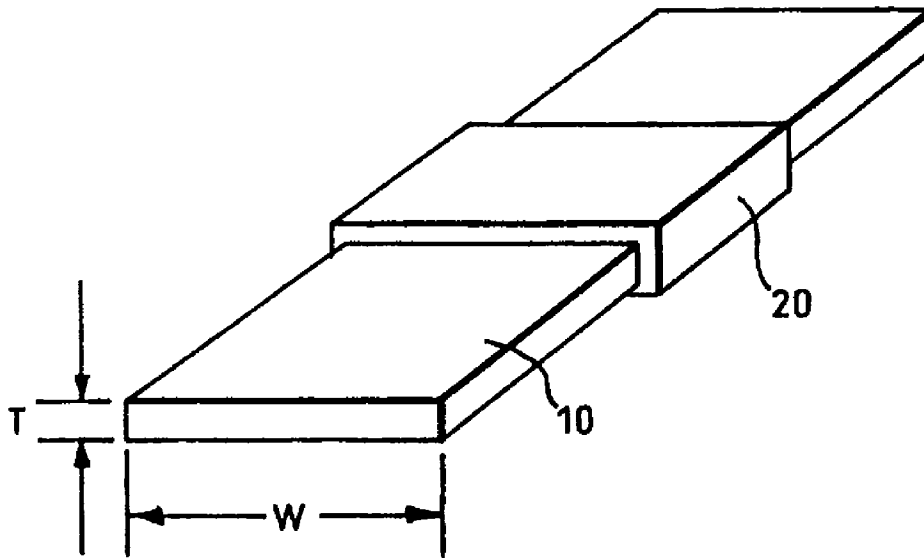

(72) BROWN, Paul Anthony, GB
(72) DICKINSON, John, GB
(71) NORWEB plc, GB
(51) Int.Cl.⁶ H01F 17/06, H01F 37/00
(30) 1996/10/28 (9622344.1) GB
(54) **BOBINE D'INDUCTANCE**
(54) **INDUCTOR**



W = width T = thickness

(57) L'invention se rapporte à une bobine d'inductance, qui comprend une barre (10) conductrice allongée de section transversale rectangulaire, dont au moins une partie est entourée d'un manchon (20) qui empêche sensiblement un courant électrique provenant de la barre conductrice de le traverser. Ainsi, ledit manchon (20) concentre les lignes d'induction magnétique. Une telle bobine d'inductance présente l'avantage qu'à des fréquences élevées (par exemple supérieures à 100 Hz), l'effet de peau est atténué tandis qu'à des fréquences moins élevées, mais à des courants élevés, la contrainte qu'elle subit est également atténuée.

(57) This invention provides an inductor including an elongate conductor bar (10) of rectangular cross section, at least part of the bar being surrounded by a sleeve (20) which provides substantially no electrical conduction path through the sleeve in a direction away from the conductor bar. Such a sleeve (20) concentrates the lines of magnetic flux in the sleeve. The advantage of such an inductor is that at higher frequencies (e.g. above 100 Hz) the effect of the "skin effect" is reduced whilst at lower frequencies but high currents the stress on the inductor is also reduced.



PCT

WORLD INTELLECTUAL PROPERTY ORGANIZATION
International Bureau

INTERNATIONAL APPLICATION PUBLISHED UNDER THE PATENT COOPERATION TREATY (PCT)

(51) International Patent Classification⁶ : H01F 17/06, 37/00	A1	(11) International Publication Number: WO 98/19318 (43) International Publication Date: 7 May 1998 (07.05.98)
(21) International Application Number: PCT/GB97/02937 (22) International Filing Date: 24 October 1997 (24.10.97) (30) Priority Data: 9622344.1 28 October 1996 (28.10.96) GB (71) Applicant (for all designated States except US): NORWEB PLC [GB/GB]; Talbot Road, Manchester M16 0HQ (GB). (72) Inventors; and (75) Inventors/Applicants (for US only): BROWN, Paul, Anthony [GB/GB]; 30 Applerigg, Kendal, Cumbria LA9 6EA (GB). DICKINSON, John [GB/GB]; 150 Mitella Street, Burnley BB10 4LW (GB). (74) Agents: HACKNEY, Nigel, J. et al.; Mewburn Ellis, York House, 23 Kingsway, London WC2B 6HP (GB).	(81) Designated States: AL, AM, AT, AU, AZ, BA, BB, BG, BR, BY, CA, CH, CN, CU, CZ, DE, DK, EE, ES, FI, GB, GE, GH, HU, ID, IL, IS, JP, KE, KG, KP, KR, KZ, LC, LK, LR, LS, LT, LU, LV, MD, MG, MK, MN, MW, MX, NO, NZ, PL, PT, RO, RU, SD, SE, SG, SI, SK, SL, TJ, TM, TR, TT, UA, UG, US, UZ, VN, YU, ZW, ARIPO patent (GH, KE, LS, MW, SD, SZ, UG, ZW), Eurasian patent (AM, AZ, BY, KG, KZ, MD, RU, TJ, TM), European patent (AT, BE, CH, DE, DK, ES, FI, FR, GB, GR, IE, IT, LU, MC, NL, PT, SE), OAPI patent (BF, BJ, CF, CG, CI, CM, GA, GN, ML, MR, NE, SN, TD, TG). Published <i>With international search report.</i>	

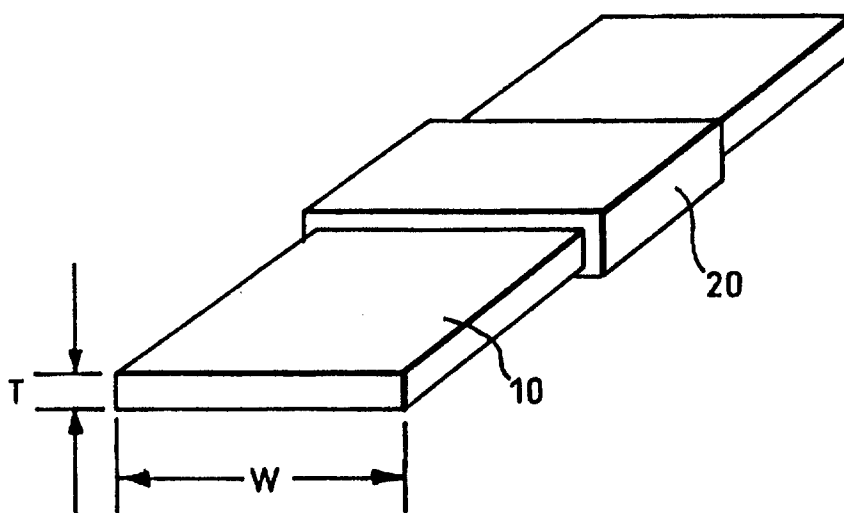
(54) Title: INDUCTOR**W = width T = thickness****(57) Abstract**

This invention provides an inductor including an elongate conductor bar (10) of rectangular cross section, at least part of the bar being surrounded by a sleeve (20) which provides substantially no electrical conduction path through the sleeve in a direction away from the conductor bar. Such a sleeve (20) concentrates the lines of magnetic flux in the sleeve. The advantage of such an inductor is that at higher frequencies (e.g. above 100 Hz) the effect of the "skin effect" is reduced whilst at lower frequencies but high currents the stress on the inductor is also reduced.

INDUCTOR

This invention relates to an inductor and to a method for producing an inductor. In particular, it relates to an inductor which is suitable for carrying
5 relatively large currents (e.g. tens, hundreds or even thousands of amps).

Such inductors may be required for use with mains
10 electricity distribution and/or transmission networks (generally referred to herein as power networks). In particular, such inductors are needed in the filter unit ("conditioning unit") described in the applicant's
15 co-pending published international patent applications, nos. PCT/GB95/00893, PCT/GB95/00894 and PCT/GB95/02023. The teaching and disclosures of those three patent applications should be referred to in relation to the present invention and are incorporated herein by
20 reference.

Previously, conventional spiral wound inductors (i.e. comprising wire wound in a spiral around a core) have been produced. However when producing high frequency filter elements using inductors of this type, which
25 elements are required to carry relatively large currents at ultra low frequencies (e.g. 50-60Hz, such as in electricity power networks), conventional spiral wound inductors become limited by their physically large dimensions. The larger the required inductance
30 and/or the larger the load current, then the larger the physical size of the inductor must be.

Furthermore, inductive elements of the type needed in conditioning units may have to withstand hundreds or
35 even many thousands of amps of load and/or fault current. They should preferably also maintain a relatively low impedance at ultra low frequencies (i.e. below 100Hz), whilst at high frequencies still maintain

an "ideal" inductor characteristic i.e. the reactance is directly proportional to the applied frequency for a fixed inductor value.

5 Spiral wound inductors suffer extremely high mechanical stresses when passing relatively large load and/or fault currents. Furthermore, conventional spiral wound inductors are limited in their high frequency performance by the interwinding capacitance i.e. the
10 capacitance offered by each turn to the next. Also the heat dissipation and power loss (commonly referred to as I^2R losses) are a particular problem in these sort of components. Therefore spiral wound inductors are not particularly desirable for this purpose.

15 The present invention aims to provide an inductor which mitigates some or all of these problems.

20 Accordingly, in a first aspect, the present invention provides an inductor including an elongate conductor bar of rectangular cross section, at least part of the bar being surrounded by a sleeve which provides substantially no electrical conduction path through the sleeve in a (or any one or all) direction away from the
25 conductor bar.

By "substantial no electrical conduction path" it is meant that for practical purposes there is minimal electrical conduction i.e. not enough (and preferably none) to be practically significant. Such a sleeve concentrates the lines of magnetic flux in the sleeve. The advantage of such an inductor is that at higher frequencies (e.g. above 100Hz) the skin effect is reduced whilst at lower frequencies but high currents
30 the stress on the inductor is also reduced. These advantages will be explained in more detail later.

35 Preferably the sleeve is elongate and preferably it has

a cross section of a hollow rectangle, although it may be of other shapes e.g. circular, square, polyface etc.

5 Preferably the sleeve encloses the conductor and preferably it lies adjacent to, or contacts, all sides of the conductor bar. Alternatively or additionally, the sleeve may surround more than one conductor bar e.g. two, three or possibly more conductor bars, with each of the conductor bars being insulated from each
10 other. A conductor bar may include one or more conductor elements e.g. may be made from stranded conductors.

15 Preferably the conductor bar has a minimum cross sectional area of 4.5mm^2 , and more preferably of 10mm^2 . Preferably the inductor can carry at least a 10A current without undue heating effects.

20 Preferably the sleeve is made of, for example, a ferromagnetic material or similar, such as a sintered or laminated material being either a conductor, semi-conductor or insulator such that there is no low impedance path within the sleeve. For example, laminated iron, laminated brass or nickel, or sintered
25 ferrite could be used.

There should be minimal or substantially no electrical conduction between the bar and the sleeve. If the sleeve is an insulating material then nothing else may
30 be necessary. However if the sleeve is a conductor or semi-conductor then an insulating layer may be included between the sleeve and the bar, although this may not be necessary depending on the materials used.

35 If the sleeve is a laminated conductor, then the lamination may be such so as to provide the high impedance within the sleeve.

Preferably, the inductor includes means for connecting it to other electrical components. Such means could be e.g. contactor pads, leads or terminals connected to the conductor bar.

5

In a further aspect, the present invention provides a method of forming an inductor comprising the step of enclosing a rectangular conductor bar with a sleeve which provides substantially no electrical conduction path through the sleeve in a direction away from the conductor bar.

10

In a further aspect, sufficient inductive reactance value(s) may be obtained, at high frequencies, in certain items of electrical plant such as cables, meters, switch gear and/or transformer bushings by retro fitting a suitable sleeve over existing conductor sections. Such conductor sections may be of any cross section or shape e.g. round, square or triangular. However, as before, the preferable solution will be for a rectangular section of the conductor element to be encased in a suitable sleeve e.g. rectangular.

15

20

In an electrical network, a suitable sleeve may also be included around a spur cable of the network at, for example, the point at which the spur cable joins a main cable. This prevents high frequency signals travelling along the spur cable from the main cable and therefore may alter the network frequency response characteristics where necessary.

25

30

The present invention also provides a communications apparatus (known herein as a "network conditioning unit") for use with a mains power network which is used to propagate both high frequency telecommunication signals and low frequency mains power signals.

35

The network conditioning unit includes a low pass filter portion or portions for filtering out the low

frequency high amplitude mains power signal i.e. separating it from the telecommunication signal(s) and allowing it to pass through the conditioning unit. The unit also includes a high pass coupling element for
5 input and removal of telecommunication signals from the network and, preferably, a terminating element of similar impedance to the impedance of the network at that point. The low pass filter portion includes an inductor according to any one of the previous aspects
10 of the invention.

The use of such a unit (as described in the applicant's three previous published PCT patent applications as described above) ensures that the (e.g. high frequency)
15 telecommunication signals do not contaminate the internal low voltage wiring present inside a premises, and/or that noise sources from the internal low voltage premises wiring do not contaminate or corrupt the high frequency telecommunication signals being transmitted
20 over the external power network.

The filter element of the present invention, which aims to reduce telecommunication signals entering the internal network of a users premises, preferably has no
25 more than 1 volt dropped across it whilst passing a 100amp load current from e.g. a 240V, 50Hz, single phase source.

Preferably the network conditioning unit provides
30 impedance matching between reception/transmission devices and the power network. Additionally the network conditioning unit may carry full load current at power frequencies (e.g. 50/60Hz) whilst still carrying the telecom signals (e.g. voice and data
35 signals), and also safely carry power frequency fault current, the magnitude and duration of which will be determined by the design parameters of the network.

The network conditioning unit preferably includes a low
40 pass filter comprising a main inductor according to an aspect of the present invention arranged between a

mains electricity input and a mains electricity output and connected at each end thereof to a signal input/output line which is arranged in parallel to the mains electricity input and mains electricity output, the two connections including a first capacitor and a second capacitor each of a predetermined capacitance depending upon the portion of the frequency spectrum which is to be utilised for communications purposes.

10 In this arrangement the main inductor is operative to prevent communication signals from the signal input/output line from entering the domestic/industrial premises. The inductor is of a value that will present a relatively high impedance at the frequencies of interest. This inductor is therefore preferably of a high inductance such as $10\mu\text{H}$ to $200\mu\text{H}$ for frequencies of 1MHz and above.

20 The first capacitor which connects the mains electricity input and the signal input/output line acts as a coupling capacitor to allow communication signals through from the signal input/output line whilst attenuating all low frequency components at or about the main electricity supply frequency (ie., 50/60Hz).

25 The second capacitor arranged between the mains electricity output and ground provides a further attenuation of communication signals.

30 To provide for the event of failure of either the first or second capacitor, each such capacitor is preferably provided with a respective fuse arranged between the first or second capacitor and the signal input/output line. Furthermore an additional safety precaution can be incorporated by provision of an additional inductor or inductors (which may be according to the present invention) arranged between the connections between the signal input/output line and the first and second capacitors. This inductor has no effect on communication frequency signals but will provide a path to ground if the first capacitor develops a fault

thereby allowing the first fuse to blow without allowing the power frequency signal onto the signal input/output line.

5

The inductance of the main inductor depends upon its design. The $10\mu\text{H}$ inductance previously specified is preferably a minimum (although inductance as low as 1 or $2\mu\text{H}$ may be contemplated) and with use of a suitable inductor a higher inductance, for example of the order of $200\mu\text{H}$, can be obtained. Alternatively, a number of inductors connected in series could be used.

10

The coupling capacitor has a capacitance preferably in the range 0.01 to $0.50\mu\text{F}$ and the second capacitor linking the mains electricity output with the signal input/output line and ground has a capacitance preferably in the range of 0.001 to $0.50\mu\text{F}$.

15

The second inductor arranged on the signal input/output line preferably has a minimum inductance of approximately $250\mu\text{H}$. This inductor therefore has minimal or no effect on communication signals at high frequency present on the signal input/output line. The conductor used to construct the $250\mu\text{H}$ inductor should be of sufficient cross-sectional area to take fault current as dictated by the series fuse link should the decoupling capacitor fail to short circuit condition.

20

Preferably, any spurious or self-resonance in the inductive or capacitive elements are avoided. As the lower cut off frequency of the conditioning unit is increased the minimum values of inductance and capacitance may be proportionally reduced.

25

In a preferred embodiment the filter is assembled in a screened box so as to provide a good earth and prevent radiation of the communication signals.

30

In a further aspect, the present invention provides an electricity distribution and/or power transmission

35

40

network (which may be a trunk and branch multipoint) at least part of which may be external to a building, the network including input means for the input onto a phase conductor of the network of a telecommunication signal e.g. having a carrier frequency greater than approximately 1MHz and output means for removing said telecommunication signal from the network, said signal preferably being transmissible along said external part of the network, the network including as part of either the input or output means (or both) communications apparatus, the communications apparatus including a low pass filter portion for allowing, in use, a low frequency high amplitude mains electricity power signal to pass along the network (e.g. to the building) and preferably for preventing (e.g. high frequency) electrical noise (e.g. from the building) entering the network (and preferably the portion of the network external to the building), and a coupling element for input and/or removal of a telecommunication signal from the network, wherein said low pass filter includes a main inductor or inductors according to an aspect of the present invention arranged between a mains electricity input and a mains electricity output.

Preferably, the network connects a plurality of separate buildings and said signal is transmissible between the buildings. Preferably, signal propagation is between a phase conductor or conductors of the network and earth or neutral, although propagation may be phase-phase.

Preferably, the network includes more than one (e.g. three) phase conductors wherein said input means is for the input of the telecommunications signal onto one or more of the phase conductors and said output means is for removing the telecommunication signal from at least one other phase conductor. Preferably, the input means is for the input of the signal onto only one of the

phase conductors. Preferably, the carrier frequency is between approximately 1-60MHz.

5 Preferably, the coupling element is suitable for use with a telecommunication signal having a carrier frequency of greater than 1MHz. Preferably, the communications apparatus includes a terminating element for terminating the apparatus in a similar impedance to
10 the impedance of the network at that point.

Preferably, the inductor is connected at the mains electricity input end to a first capacitor and at the mains electricity output end to a second capacitor,
15 said first capacitor connecting the mains electricity input to a signal input/output line, and said second capacitor connecting the mains electricity output to ground.

20 In a further aspect, the present invention provides a method of signal transmission including input of a telecommunication signal e.g. having a carrier frequency of greater than approximately 1MHz onto a phase conductor of an (e.g. trunk and branch
25 multipoint) electricity power distribution and/or transmission network at least part of which may be external to a building and subsequent reception of the signal, said signal preferably being transmitted along said external part of the network, wherein said signal
30 is input onto and/or received from the network using communications apparatus, the apparatus including a low pass filter portion including an inductor according to an aspect of the present invention for allowing a low frequency high amplitude mains electricity power signal
35 to pass through the communications apparatus (e.g. from the network to a consumer's premises and for preventing electrical noise from the premises entering the network), and a coupling element for input and/or

removal of the telecommunication signal from the network.

5 Preferably, the communications apparatus directs the telecommunication signal into the network away from the consumer's premises.

10 In a further aspect, the present invention provides an inductor including an elongate conductor bar, at least part of the bar being surrounded by a sleeve which provides substantially no electrical conduction path through the sleeve in a direction away from the conductor bar, the inductor having an inductance of at least $1\mu\text{H}$, preferably $5\mu\text{H}$, preferably $10\mu\text{H}$, more
15 preferably $50\mu\text{H}$ or $100\mu\text{H}$ and possibly at least $250\mu\text{H}$ or $500\mu\text{H}$ or 1mH . The invention also contemplates a corresponding method of making such an inductor.

20 Embodiments of the present invention will now be described with reference to the accompanying drawings in which:

Figure 1 is a schematic diagram of an inductor according to a first aspect of the present invention;
25

Figure 2 is a schematic diagram of a conductor of circular cross-section;

30 Figure 3 is a schematic diagram of a strip conductor of rectangular cross-section;

Figure 4 is a diagram showing the connection of two cables according to an aspect of the present invention;

35 Figure 5 is an equivalent electrical circuit diagram of a coupler according to an aspect of the present invention;

Figure 6 is a schematic diagram of an inductor according to a further aspect of the present invention;

5 Figure 7 is a first embodiment of a network conditioning unit for use with the present invention;

Figure 8 is a plan view of a network conditioning unit according to figure 12;

10 Figure 9 is a view of a circuit board for the network conditioning unit of figure 8;

15 Figure 10 is a schematic diagram of a network conditioning unit according to an aspect of the present invention;

Figure 11a and 11b are schematic diagrams of network conditioning units as used with the present invention;

20 Figure 12 is a second embodiment of a network conditioning unit for use with the present invention; and

25 Figure 13 shows a further embodiment of the present invention.

30 Figure 1 shows an embodiment of an inductor according to an aspect of the present invention. The conductor comprises a conductor bar (10) surrounded by a sheath (20). The conductor bar (10) has a width "W" and a thickness "T".

35 The advantages provided by the geometry of the inductor of figure 1 will be better understood by considering the analysis given below of the conductors shown in figures 2 and 3. Figure 2 shows a cylindrical conductor of length "L" and diameter "D", whilst figure 3 shows a generally rectangular conductor of length

12

"L", width "W" and thickness "T".

For a circular conductor of length "L" and diameter "D"

5 Cross Sectional Area (CSA) of conductor = $\frac{\pi D^2}{4}$

Circumference of conductor = πD

Surface Area (SA) of conductor = $\pi D \times L$

10

where $\pi = 3.142$

D = conductor diameter

L = conductor length

15 for D = 1 unit, the CSA = $\frac{\pi}{4}$ Sq.units or $\left(\sqrt{\frac{\pi}{4}}\right)^2$
units

the circumference = π

The SA = πL

20 For a rectangular strip conductor of width "W"
thickness "T" and length "L"

Cross Sectional Area (CSA) of conductor = $W \times T$

Circumference of conductor = $2[W+T]$

25 Surface Area (SA) of conductor = $2L[W+T]$

for a rectangular strip conductor with a CSA of $\frac{\pi}{4}$ sq
units we have $W \times T = \frac{\pi}{4}$
and $2[W+T] =$ circumference of bar.

30

The circumference is a minimum when $W=T$ i.e. bar has
square cross-section and circumference = $4W=4T$
and $W^2 = \frac{\pi}{4}$

35 Therefore the circumference of the bar = $4 \times \frac{\sqrt{\pi}}{2} = 2\sqrt{\pi}$
which is greater than π . Hence the circumference of a
square bar is greater than the circumference of a
circular bar for a fixed CSA.

Then in general for a constant CSA as $W \rightarrow \infty$,
 $T \rightarrow 0$ or as $T \rightarrow \infty$, $W \rightarrow 0$. Therefore $2 [W+T]$ is always
greater than π .

5 Therefore the circumference of a rectangular bar is
always greater than the circumference of a circular bar
for equal CSAs.

10 It therefore follows that for a given CSA of circular
conductor, a rectangular conductor with the same CSA
will have a greater circumference, which approaches
infinity as its thickness becomes very small.

15 It further follows that if the above conductors each
have length "L" units then the surface area of the
rectangular strip conductor will also approach infinity
as its thickness becomes very small.

20 These dimensional relationships between circular and
rectangular conductors have considerable significance
in conductor design(s) as the following properties
apply:-

- 1. At ultra low frequencies [d.c (0Hz) to about
25 100Hz] electric currents propagate almost equally
throughout the CSA of a conductor.
2. At higher frequencies (above 100Hz) electric
30 currents tend to migrate towards the outer
surfaces of a conductor. This effect is termed
the "skin effect" of the conductor. The changes
imposed by the skin effect will be less in a
rectangular type of conductor when compared with a
circular conductor of the same CSA. A rectangular
35 conductor made of the same material and of the
same CSA will therefore have a much increased high
frequency current carrying capability.

3. As electric currents are passed through a conductor the reactance of that conductor creates a heating effect within the conductor which effectively limits the maximum current which it might carry. For any given CSA of conductor the rectangular type of conductor can be designed such that the ratio of thickness to width gives a much greater surface area and hence cooling capability than its circular equivalent.

For all of these reasons, use of a rectangular conductor is an improvement on the use of a circular conductor.

The inductance of a coil of wire may be increased by forming the coil around a core of suitable material with which to concentrate the lines of magnetic flux. For example, iron, brass and various grades of ferrite may be used as material for the core. The conductor may also be sleeved with these types of material i.e. wholly or partially surrounded by a sleeve.

If a rectangular type conductor is sleeved with, say, ferrite, as shown in Figure 1, then its inductive reactance will be greatly increased at high frequencies and yet have little or no change at ultra-low frequencies i.e. d.c. (0Hz) to approx. 100Hz.

Therefore, when such rectangular sleeved inductors are incorporated in high, low and bandpass filter designs (such as these utilised in the design of High Frequency Conditioned Power Network (HFPCPN) directional couplers - conditioning units) and in the provision of low and high pass filter elements for high frequency conditioned power networks, the problems associated with I^2R losses (conductor heat losses) and the relatively large physical size of inductors may be reduced or overcome.

At ultra-low frequencies i.e. up to say 100Hz
(electricity distribution networks are typically 50 or
60Hz and may also be direct current i.e. 0Hz), the
ferrite sleeve has negligible effect on the rectangular
5 conductor's performance. However, at frequencies above
1MHz the sleeve has a pronounced effect giving a
relatively high inductive reactance value and when
interconnected to suitable decoupling capacitance
produces high attenuation to the high frequency
10 signals.

Conventional inductors suffer a problem at high
frequencies due to their interwinding capacitance i.e.
the capacitance offered by each turn to the next. By
15 utilising a rectangular sleeved reactance type of
inductor this interwinding capacitance effect is
minimised. The reactive sleeving material may be coated
onto the conductor over an insulative membrane if
required or included in a suitable adhesive resin
20 compound and formed over the conductor.

Heat dissipation may also be improved in this way and
the sleeving technique may be included in power cable
joints in order to develop high frequency directional
25 coupling within the joint housing (400) as illustrated
in Figure 4 for joining two polyphase cables (402,
410). Figure 5 illustrates the equivalent electrical
circuit diagram which has a directional coupling effect
at high frequencies.

30
Optimum coupling is from polyphase cable (402) to/from
single phase cable (404) via connector (406) with
minimal coupling to cable (402) due to the series
inductors L_{10} , L_{20} and L_{30} produced by the ferrite
35 sleeves (408) as shown in Figure 4. The cable phase
conductors may be of any cross section e.g. circular,
wedge shaped, square or rectangular, and are provided
with ferrite sleeves either on each conductor or formed

over the bunched conductors. They may have rectangular sections formed at the sleeves to produce optimum performance as previously described.

5 Such sleeved inductive components may be included in electrical network joints as shown in figure 4 (and schematically in figure 5), or mounted inside equipment such as transformers and switchgear housings, in electricity meter housings or in electrical appliances.
10 Indeed electricity meter current coils may be sleeved such that their reactance increases with frequency and may form part of an integral filter or high frequency directional coupler or HFPCN "conditioning unit".

15 Similarly, fuse elements may be sleeved and have elements formed from rectangular section conductors in order that their inductive reactance might increase with frequency and that they might form part of a directional coupler or HFPCN conditioning unit.

20 It might be that a sufficient inductive reactance value(s) might be obtained, at high frequencies, in certain items of electrical plant such as cables, meters, switchgear and transformer bushings by
25 retrofitting suitable ferrite sleeves over existing conductor sections (e.g round, elliptical, polysided, rectangular, square or triangular etc). This is illustrated Figure 6. The preferable solution is for a rectangular section of a similar area to be suitably
30 sleeved with ferrite or other similar material.

Figure 13 shows a three core cable 1300, around the cores of which is fitted a sleeve 1320 according to the present invention in order to form an inductive
35 element. The sleeves could of course be "retro-fitted" to an already laid conductor cable and also not all of the conductors need to be fitted with sleeves. Furthermore, the cable could of course include more or

less than three conductors.

The cable 1300 comprises an outer cable sheath 1330 inside which is a neutral earth sheath 1340.
5 Surrounding the three conductors 1310 is a layer of insulative filler 1350 which keeps the conductors away from the neutral earth sheath 1340. Each of the conductors are covered by respective separate insulative sheaths 1360 and all three conductors are
10 surrounded by a single sleeve 1320 according to the present invention.

The sleeve 1320 contains a quantity of ferromagnetic material which is chosen to be proportional to the
15 vector sum of the 50/60Hz current in the polyphase conductors 1310. The properties of the material affect the quantities utilised or required. The sleeve may be split to facilitate its ease of fitting (i.e. ensuring that there is no need to cut the conductors) and may be
20 held in place by a non-metallic clamp or "P"-clip 1370. The value of inductance produced by this arrangement will depend on the type or grade of ferromagnetic material used, its overall length and its proximity to the conductors. The greater the thickness of the
25 ferromagnetic sleeve the less likely it is that it will saturate due to the 50/60Hz vector sum of the polyphase current in the conductors.

A suitable material for the sheath could be Neosid MMG
30 ferrite grade F9C. For a sleeve having dimensions, for example, of external diameter 63mm, internal diameter 38mm and thickness 25mm, the magnitude of the vector sum of the current flowing in one direction through the ferrite is approximately 25 amps when saturation begins
35 to occur. Saturation current can be increased by fitting a thicker sleeve with the same internal diameter. In this example, the arrangement produces an inductance of 11 μ H per 25mm of length. Inductance can

be increased by increasing the length of the ferrite and this increase is linear i.e. a 50mm length giving 22 μ H etc.

5 The basic elements of a network conditioning unit 1104 according to one aspect of the present invention are illustrated in Figs. 11a and 11b. Fig. 11a shows a conditioning unit 1104 (as also designated 1000 in fig. 10). The conditioning unit can be considered to be
10 equivalent to a low pass filter 1100 and a coupling capacitor element 1102 (which can be considered to be a high pass filter element).

15 The low pass filter element 1100 allows mains power to be supplied from the distribution network to a consumer whilst preventing high frequency communication signals from entering the consumers premises. A coupling capacitor, or high pass filter element, 1102 is
20 provided to couple the high frequency communication signals onto the distribution network whilst preventing the mains power from entering the communications apparatus.

25 The conditioning unit components may be fitted into e.g. an electricity meter case located in a consumer's premises, or possibly may be set into a compartment at the rear of such a meter. Alternatively the necessary components may be located in e.g. a customer's high rupturing capacity (HRC) fuse or cut-out unit.

30 Referring to Fig. 12, an embodiment of a conditioning unit (essentially a filter) according to an aspect of the invention is indicated generally by the reference numeral 1200 and is connected between a mains
35 electricity input 1202 and a mains electricity output 1204. A signal input/output line 1206 is also connected into the filter. The mains power line is a standard 50Hz or 60Hz mains electricity power supply providing a domestic electricity power source of 110v
40 or 240v at a maximum current of 100 amps for normal usage.

The filter 1200 may be assembled into a shielded box which prevents radiation of the communication signals to externally located appliances and which provides a connection 1208 to earth for the signal input/output line 1206. The filter 1200 includes a first or main inductor 1210 according to an aspect of the present invention. This provides an inductance of approximately $50\mu\text{H}$. This may be a minimum for the signal characteristics utilised, or possibly an inductor of $10\mu\text{H}$ or less would suffice. The use of different materials or a plurality of series inductors may increase the inductance of the inductor up to, for example, approximately $200\mu\text{H}$.

An end of the main inductor 1210 is provided with a connection to the signal input/output line 1206. A first connection 1212 between the mains electricity input 1202 and signal input/output line 1206 comprises a first or coupling capacitor 1214 having a capacitance of between 0.01 and $0.50\mu\text{F}$, and preferably around $0.1\mu\text{F}$. This coupling capacitor 1214 is connected to a first fuse 1216 which is arranged to blow in the event of failure or a fault developing in capacitor 1214.

A second connection 1218 includes a second capacitor 1220 having a capacitance of between 0.001 and $0.50\mu\text{F}$, preferably around $0.1\mu\text{F}$. This capacitor provides further attenuation of the communication signals by shorting to the earth or ground 1208. A second fuse 1222 is provided to blow if a fault develops in the second capacitor 1220, thereby preventing further unit damage.

The signal input/output line 1206 is connected to a second inductor 1224 which may be constructed in accordance with the present invention and having an inductance of approximately $250\mu\text{H}$ minimum. This inductor is provided as a damage limiter in the event of failure of the coupling capacitor 1204. In the event of such failure this inductor provides a path to

the ground 1208 for the 50Hz mains electricity power frequency, thereby blowing fuse 1206. The inductor has no effect on the communication frequency signals present on the signal input/output line 1206.

5

Fig. 7 shows a circuit diagram of a second embodiment of a filter according to an aspect of the present invention. The filter 700 includes a pair of inductors L1, L2 (which may be constructed in accordance with the present invention) arranged in series between a mains electricity input 720 and a mains electricity output 740. A preferred value for L1 and L2 is approximately 16 μ H. L₁ and L₂ may be of different values to reduce harmonic response relationships. Connected between the RF input line 760 and the mains input 720 is a first fuse F1 and capacitor C1, and connected between the RF input 760 and ground is a third inductor L3, (which may also be constructed in accordance with the present invention) which acts as an RF choke and has a typical value of 250 μ H.

10

15

20

Connected in a similar fashion between the connection point of L1 and L2 and ground is a second fuse F2 and second capacitor C2. Connected between the mains electricity output 74 and ground is a third fuse F3 and third capacitor C3. A typical value for the capacitors is around 0.1 μ F and for the fuses approximately 5 amps HRC (high rupturing capacity).

25

30

The values given for these components are exemplary only, and different preferred values will be appropriate for other design frequencies and electricity network parameters.

35

40

Turning to Fig. 8 a typical housing arrangement for a network conditioning unit according to an embodiment of the present invention is shown. The main inductors L1 and L2 are housed within a shielding box 820. L1 and L2 are shown as coil inductors, but could be replaced by inductors according to the present invention. Various connections are shown, including a

communication interface port 800 to which a user's communication equipment would normally be connected. However, as shown in Fig. 8, this port may be terminated in an impedance matching port terminator 810.

Fig. 9 shows a circuit board 96 which fits inside the unit 820 of figure 8 and houses the rest of the circuitry for the network conditioning unit of figure 7. Connections A, B, C, D and E are shown which connect to the appropriate points of the box shown in figure 8.

Fig. 10 is a schematic representation of a network conditioning unit 1000, showing the various building blocks 1005-1060 of the network conditioning element. To design a suitable network conditioning unit, the circuits represented by blocks 1010 and 1060 should be high-impedance elements over the required communications frequency spectrum (eg. 1MHz and above) and low impedance elements at frequency of mains electricity supply (ie. 50/60Hz) i.e. these elements are inductors. Similarly blocks 1005 and 1020 should be low impedance coupling elements over the required communications frequency spectrum and high impedance isolating elements at the frequency of the mains electricity supply ie. they are capacitors.

HRC fault current limiting fusible safety links (1040 and 1050) are provided in series with elements 1005 and 1020. An additional impedance matching network 1030 may be included for connection to a communications port. This element may be external to the network conditioning unit 1000.

The optimum values of items 1010, 1005, 1020 and 1060 will be dependant upon factors including:-

a) The required frequency range over which the network is to be conditioned.

b) The unit length of the network which is to be conditioned.

5 c) The number and types of loads which may be encountered on the network.

10 d) The characteristic impedance of the network phase conductors with respect to each other and/or earth (as appropriate) i.e. conductor outer electrical sheath.

e) The impedance of the communications interface devices.

15 The network conditioning unit may be filled with air, inert gas, resin compound or oil depending upon the location and load and/or fault current ratings of the conditioning unit. Also it may be, for example, sited indoors, pole mounted, buried underground or inserted in street lamp columns.

20 Similarly items 1010 and 1060 may comprise a number of individual inductors in series, and if no interconnection is required, for example, on some street lights, items 1040, 1005, 1030 and 1060 may be
25 omitted.

Items 1005 and 1020 may comprise of a number of capacitors in series and/or parallel configuration depending upon working voltages encountered ie. 240,
30 415, 11kV, 33kV etc. Alternatively, or additionally, items 80 and 82 may comprise of two or more capacitors in parallel in order to overcome, for example, deficiencies in capacitor design when conditioning a network over a relatively wide frequency range, for
35 example 50 MHz to 500 MHz.

Furthermore, items 1010, 1050 and 1020 of the network conditioning unit may be cascaded if required. In a
40 typical design, the greater the number of cascaded elements the sharper will be the roll-off response of the filter and the greater its attenuation, subject to

avoidance of resonances etc.

The above embodiments of the present invention have been described by way of example only and various
5 alternative features or modifications from what has been specifically described and illustrated can be made within the scope of the invention, as will be readily apparent to a person skilled in the art.

Claims:

1. An inductor including a plurality of elongate conductor bars, at least part of the bars being surrounded by a single ferromagnetic sleeve which provides substantially no electrical conduction path through the sleeve in a direction away from the conductor bars with each of the conductor bars being insulated from each other.
2. An inductor according to claim 1 having an inductance of at least $1\mu\text{H}$.
3. An inductor according to claim 1 or claim 2 wherein the sleeve is elongate and has a cross section of a hollow rectangle.
4. An inductor according to any one of the above claims wherein the sleeve encloses the conductor and lies adjacent to, or contacts, all sides of the conductor bar.
5. An inductor according to any one of the above claims wherein each of the conductor bars in use is a different phase conductor from the other bar(s).
6. An inductor according to any of the above claims wherein the conductor bar has a minimum cross section area of 4.5mm^2 .

7. An inductor according to any of the above claims wherein the inductor can conduct at least a 10A current.
- 5 8. An inductor according to any one of claims 1 - 7 wherein the conductor bars are each of rectangular cross section.
- 10 9. An inductor according to any one of the above claims wherein the sleeve is made of conductive or semi-conductive material.
- 15 10. An inductor according to any one of the above claims wherein an insulating layer is included between the sleeve and the bar or bars.
- 20 11. A communications apparatus for use with a mains power network which is used to propagate both high frequency telecommunication signals and low frequency mains power signals, the apparatus including a low pass filter portion for filtering out the high frequency signal and allowing the low frequency high amplitude mains power signal to pass through the apparatus, and the apparatus also including a high pass coupling
25 element for input and removal of telecommunication signals from the network wherein the low pass filter portion includes an inductor according to any one of the above claims.

12. Apparatus according to claim 11 wherein the inductor is arranged between a mains electricity input and a mains electricity output and connected at one end thereof to a signal input/output line.

5

13. Electricity distribution and/or power transmission network, the network including input means for the input onto a phase conductor of the network of a telecommunication signal and output means for removing
10 said telecommunication signal from the network, the network including as part of either the input or output means (or both) communications apparatus according to claim 10 or claim 11 for allowing, in use, a low
15 frequency high amplitude mains electricity power signal to pass along the network and for the input and/or removal of a telecommunication signal from the network.

14. A network according to claim 13 which connects a plurality of separate buildings and said signal is
20 transmissible between the buildings.

15. A network according to claim 13 or claim 14 which includes more than one phase conductor wherein said input means is for the input of the telecommunications
25 signal onto one or more of the phase conductors and said output means is for removing the telecommunication signal from at least one other phase conductor.

16. A network according to claim 13,14 or 15 wherein
30 the communication apparatus is suitable for use with a

telecommunication signal having a carrier frequency of greater than 1MHz.

5 17. A method of signal transmission including input of a telecommunication signal onto a phase conductor of an electricity power distribution and/or transmission network and subsequent reception of the signal, wherein said signal is input onto and/or received from the network using communications apparatus according to
10 claim 11 or claim 12.

18. A method of forming an inductor comprising the step of enclosing a plurality of rectangular conductor bars with a single ferromagnetic sleeve which provides
15 substantially no electrical conduction path through the sleeve in a direction away from the conductor bar and in which each of the conductor bars being insulated from each other.

20 19. A method of forming an inductor according to claim 18 wherein the inductor has an inductance of at least $1\mu\text{H}$.

25 20. A method according to claim 18 or 19 wherein the sleeve is elongate and has a cross section of a hollow rectangle.

30 21. A method according to any one of the claims 18-20 wherein the sleeve encloses the conductor and lies adjacent to, or contacts, all sides of the conductor

bar.

22. A method according to any one of claims 18-21
including wherein each of the conductor bars in use is
5 a different phase from the other bar(s).

23. A method according to any one of claims 18-22
wherein the conductor bar has a minimum cross sectional
area of 4.5mm^2 .

10

24. A method according to any one of claims 18-23
wherein the inductor can conduct at least a 10A
current.

15 25. A method according to any one of claims 18-24
wherein the sleeve is made of a ferrite.

26. A method according to any one of claims 18-25
wherein the sleeve is made of conductive or semi-
20 conductive material.

27. A method according to any one of claims 18-26
including an insulating layer is included between the
sleeve and the bar or bars.

25

1/9

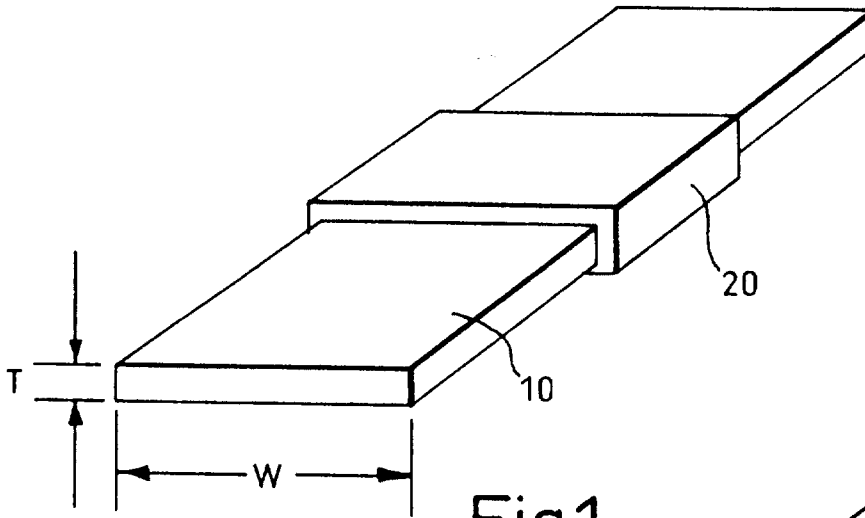

W = width T = thickness

Fig.1.

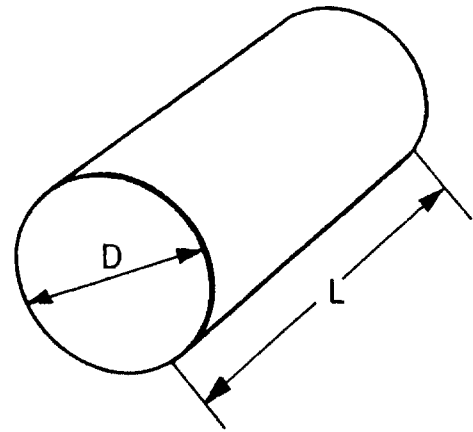

Fig.2.

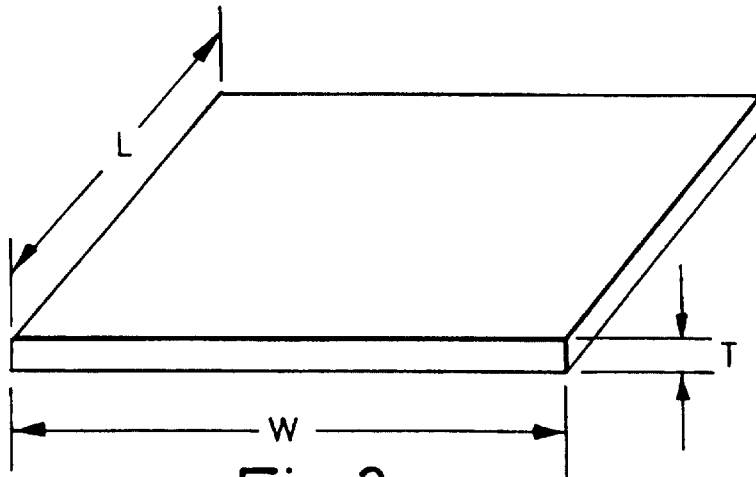

Fig.3.

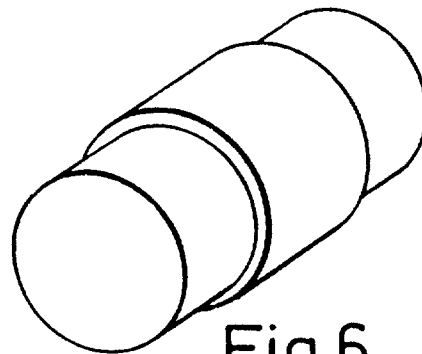

Fig.6.

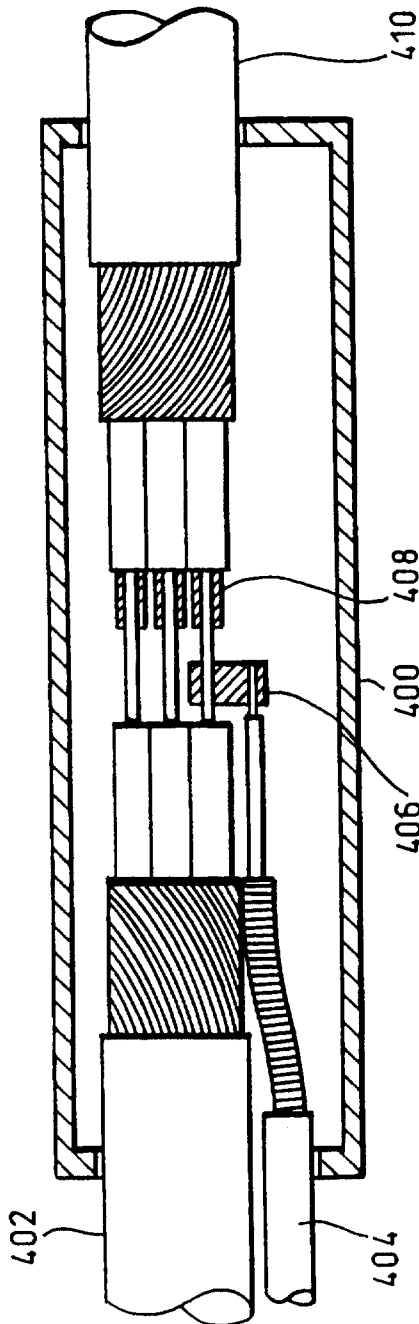

Fig.4.

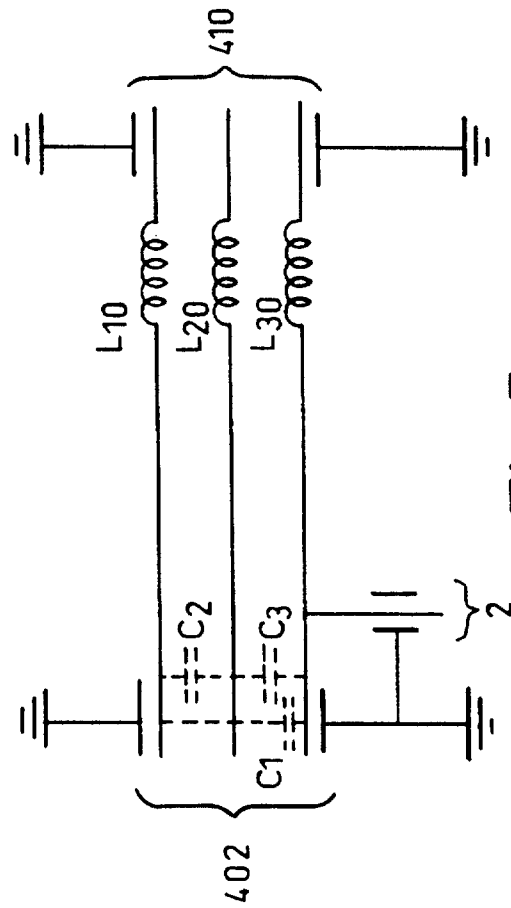

Fig.5.

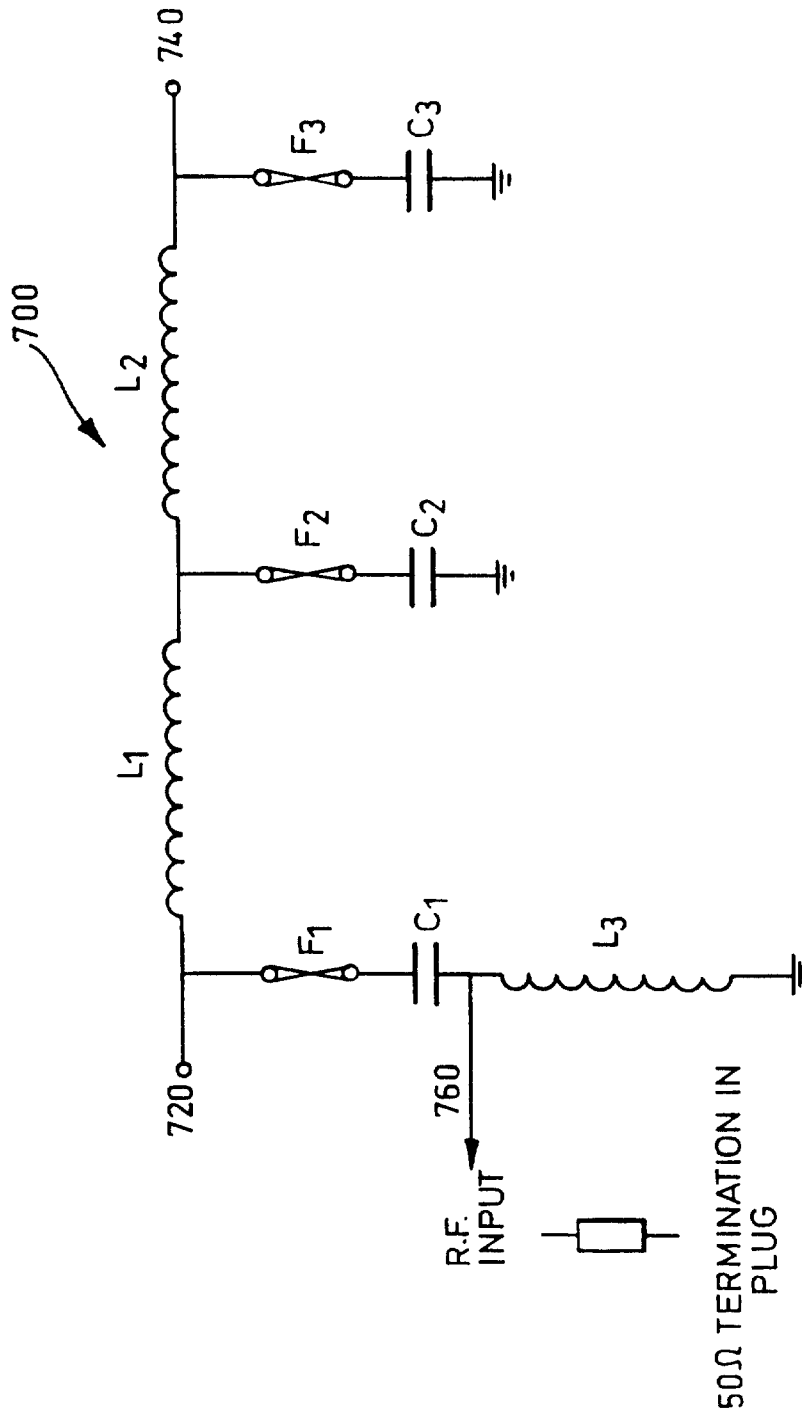

Fig.7.

4 / 9

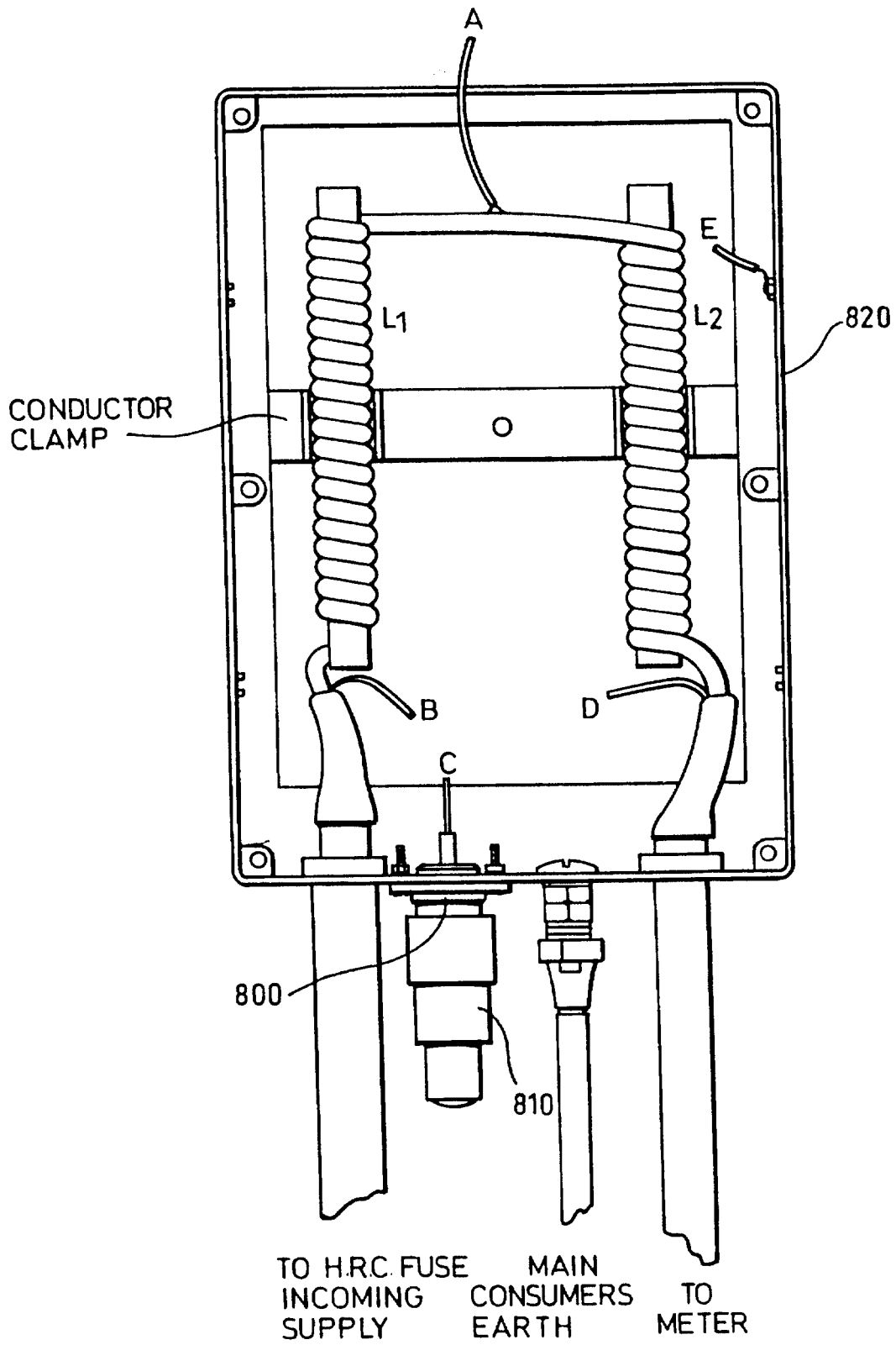

Fig.8.

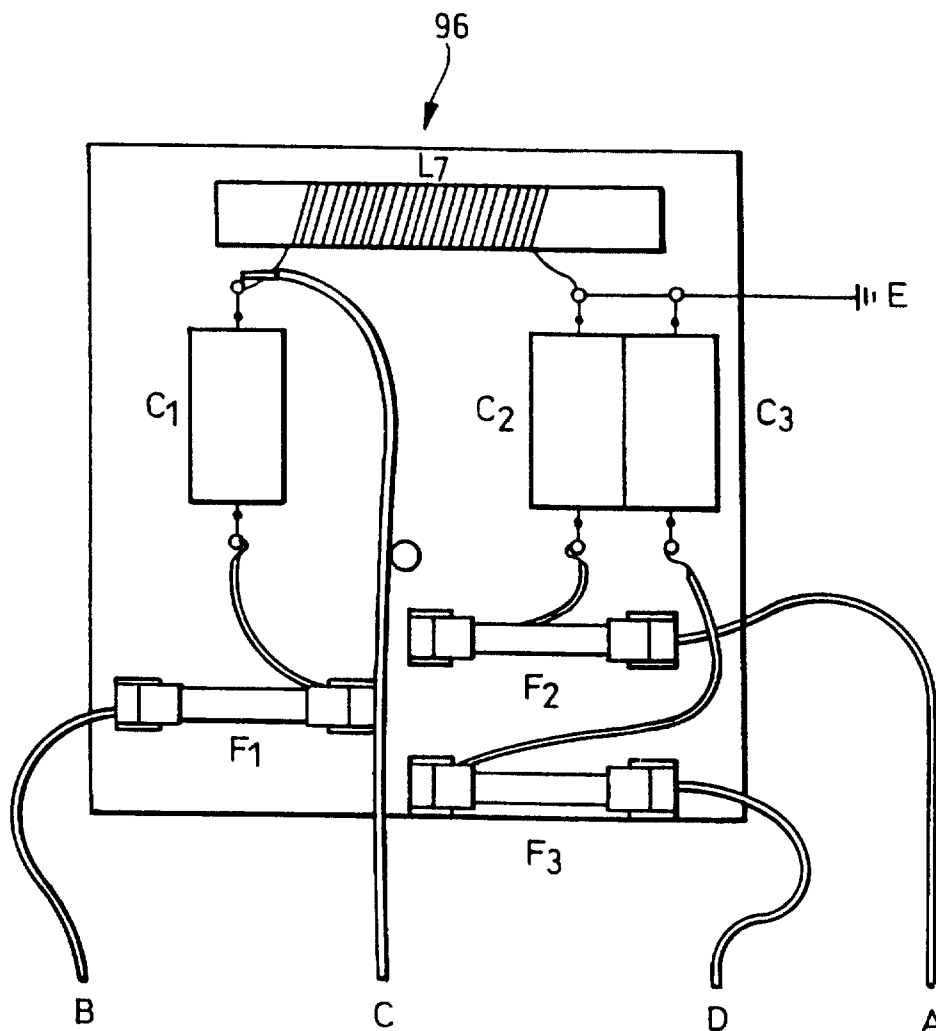

Fig.9.

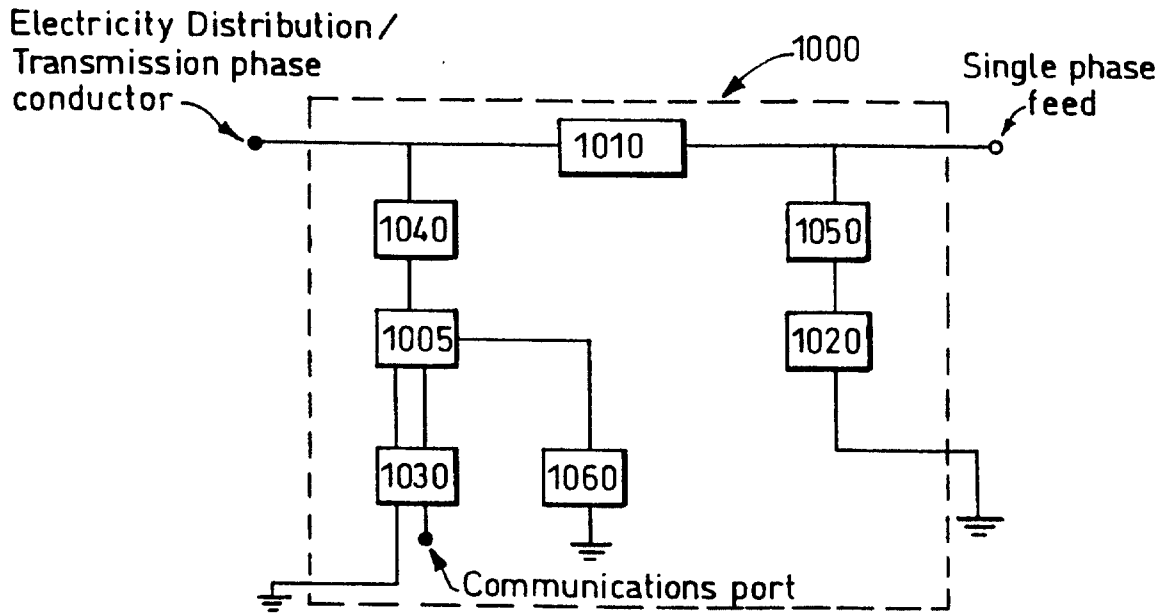

Fig.10.

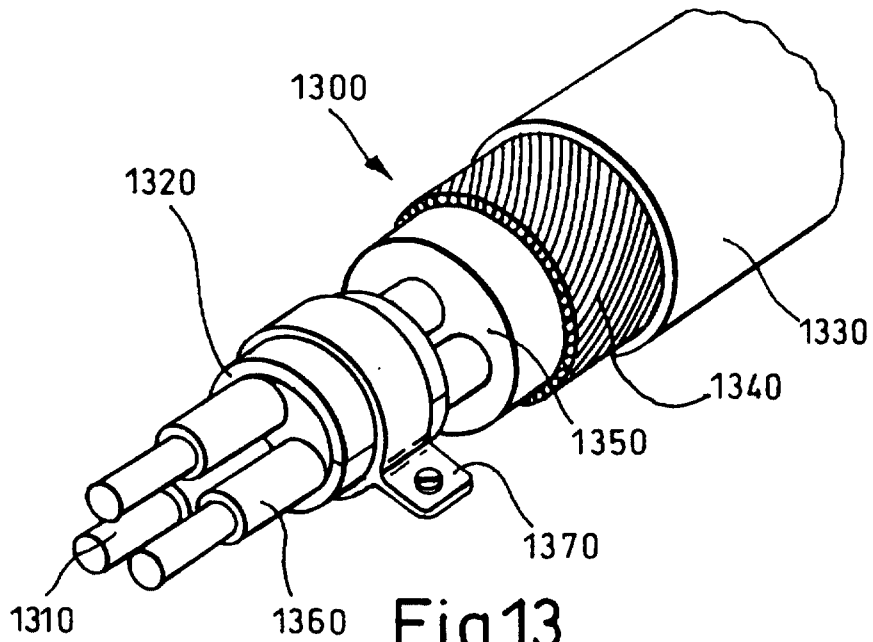

Fig.13.

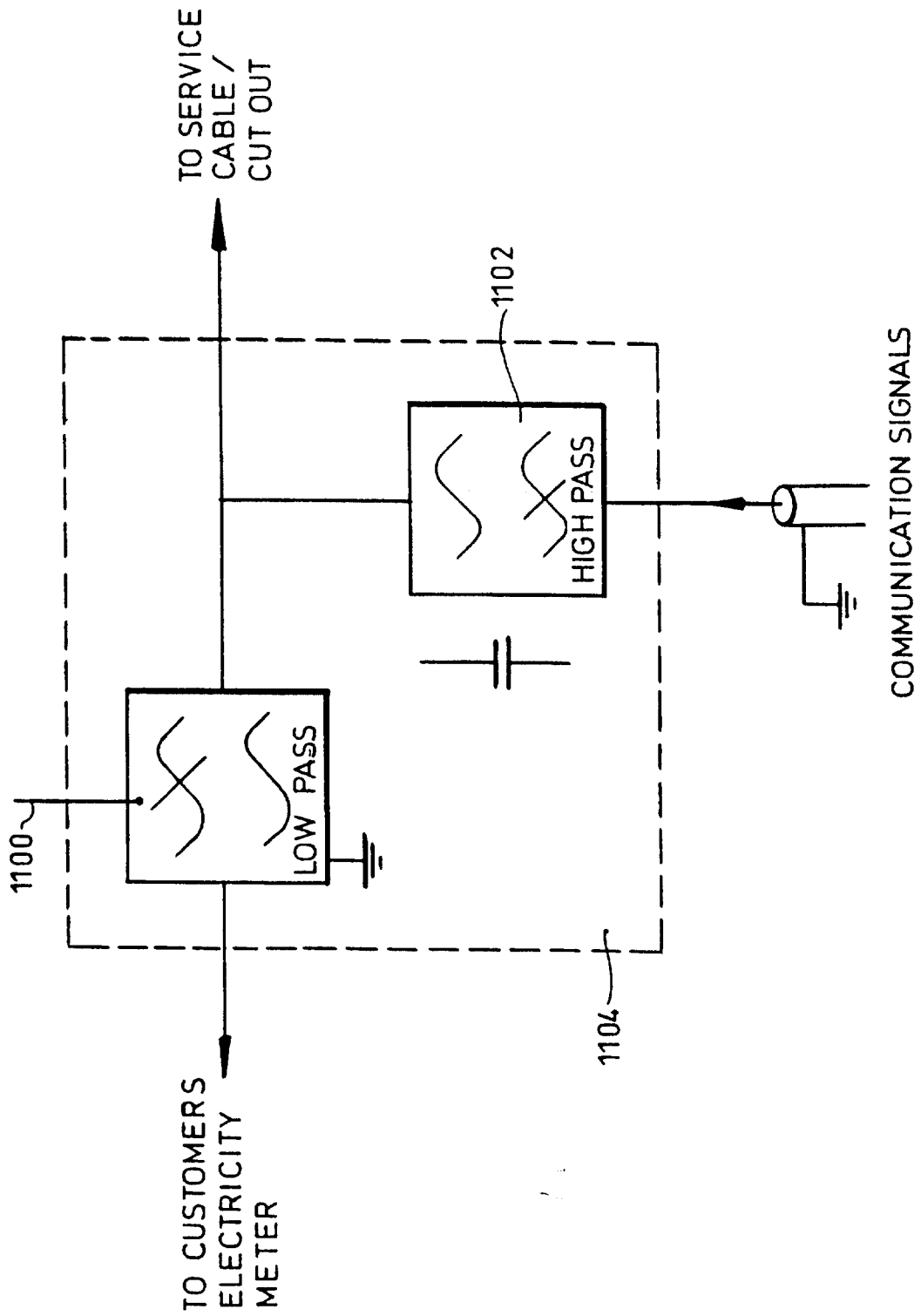

Fig.11a.

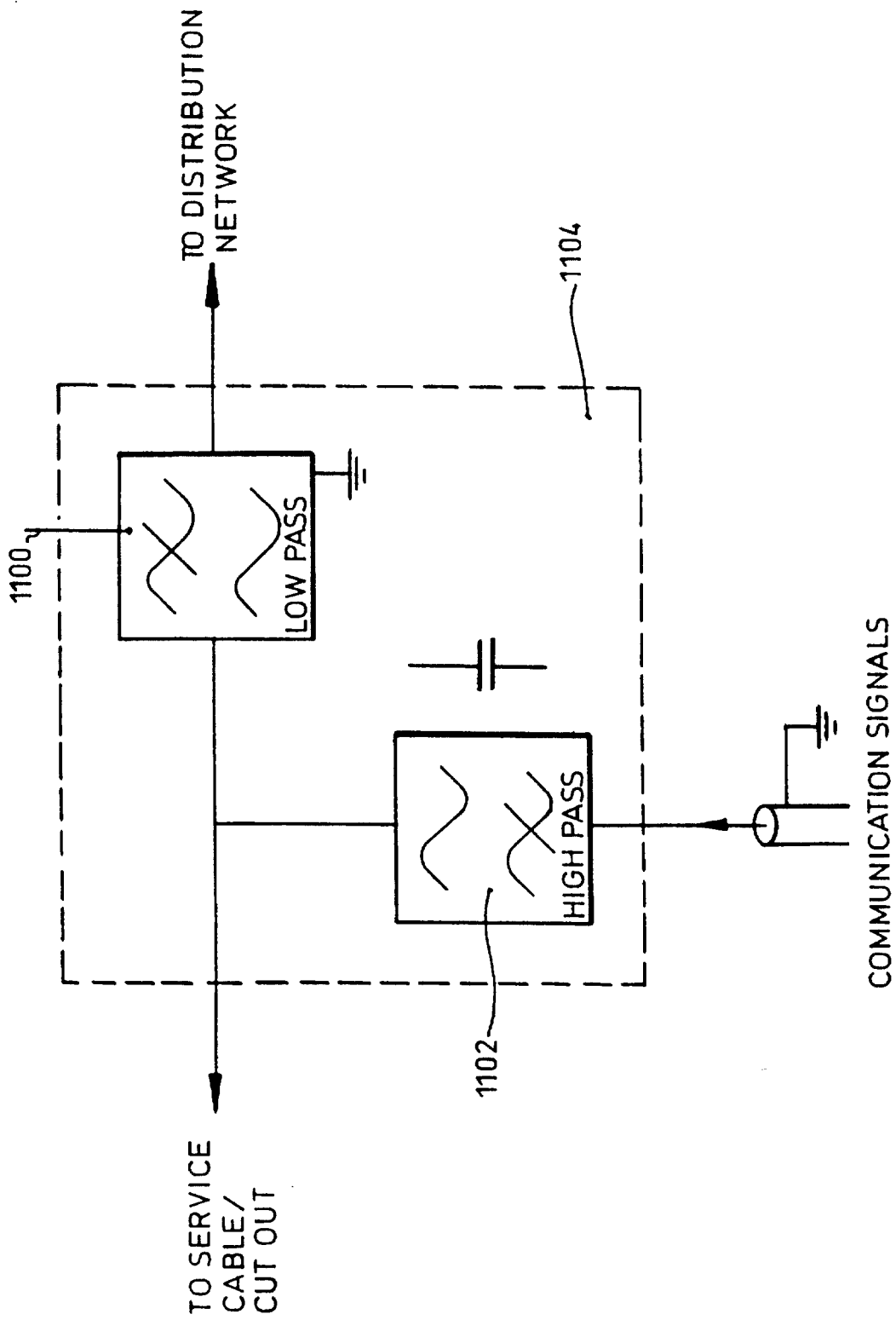

Fig.11.

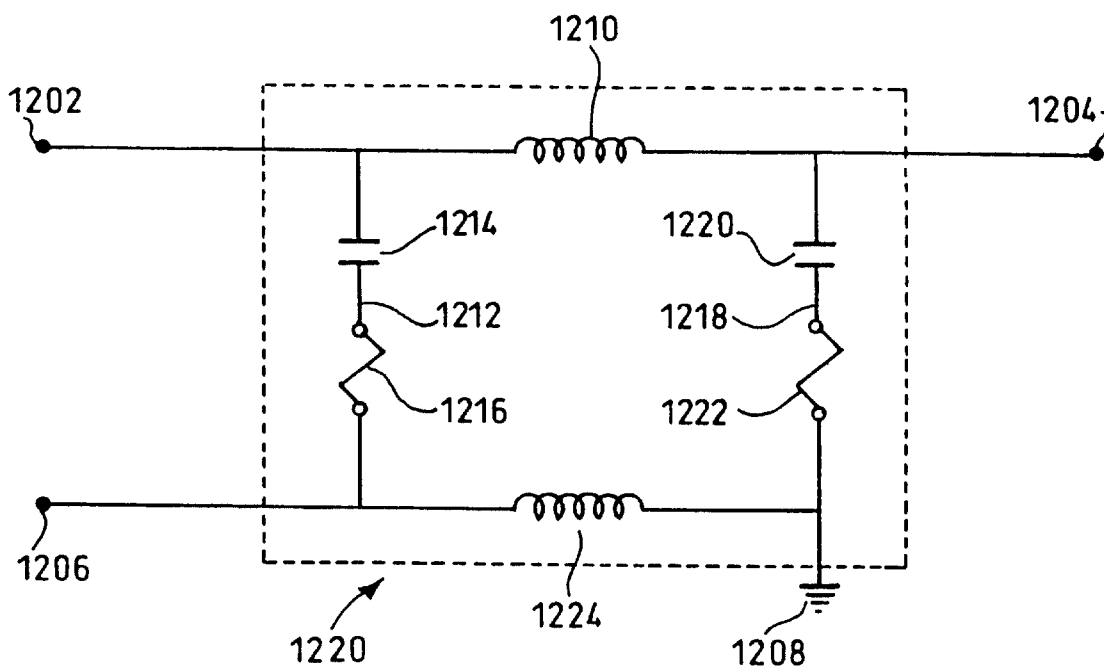
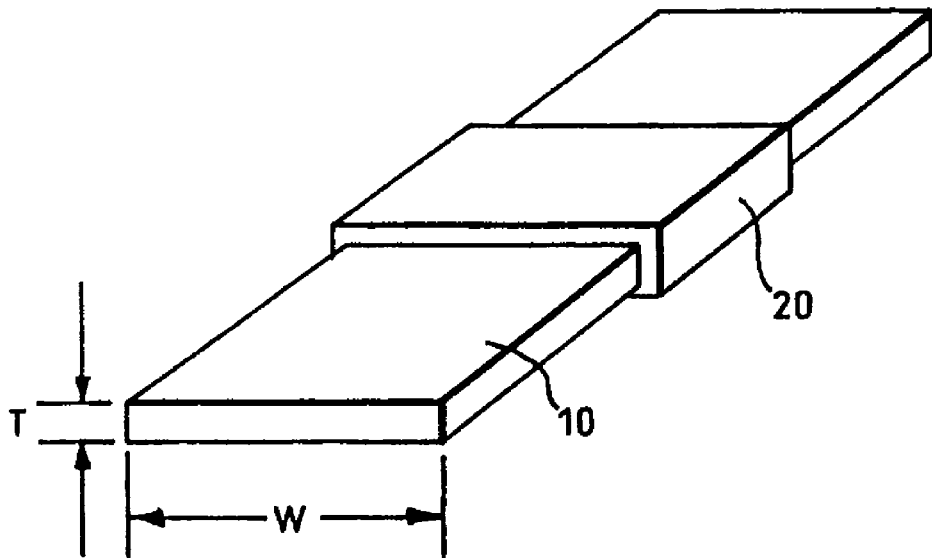

Fig.12.



W = width T = thickness