

(19) World Intellectual Property Organization  
International Bureau



(43) International Publication Date  
9 January 2003 (09.01.2003)

PCT

(10) International Publication Number  
**WO 03/002043 A2**

- (51) International Patent Classification<sup>7</sup>: **A61F 5/44**
- (21) International Application Number: PCT/DK02/00448
- (22) International Filing Date: 28 June 2002 (28.06.2002)
- (25) Filing Language: English
- (26) Publication Language: English
- (30) Priority Data:
- |               |                                |    |
|---------------|--------------------------------|----|
| PA 2001 01041 | 29 June 2001 (29.06.2001)      | DK |
| 09/893,514    | 29 June 2001 (29.06.2001)      | US |
| PA 2001 01386 | 24 September 2001 (24.09.2001) | DK |
| PA 2001 01870 | 13 December 2001 (13.12.2001)  | DK |
| PA 2001 01869 | 13 December 2001 (13.12.2001)  | DK |
| 10/026,819    | 27 December 2001 (27.12.2001)  | US |
| PA 2002 00569 | 17 April 2002 (17.04.2002)     | DK |
| PA 2002 00570 | 17 April 2002 (17.04.2002)     | DK |
| PA 2002 00895 | 13 June 2002 (13.06.2002)      | DK |
- (71) Applicant (for all designated States except US): **COLO-PLAST A/S** [DK/DK]; Høltedam 1, DK-3050 Humlebæk (DK).
- (72) Inventors; and
- (75) Inventors/Applicants (for US only): **TANGHØJ, Allan** [DK/DK]; Jellerød Have 59, DK-2980 Kokkedal (DK). **JENSEN, Lars, Bøgelund** [DK/DK]; Birkely 143, DK-3200 Helsingør (DK).
- (74) Agent: **PLOUGMANN & VINGTOFT A/S**; Sundkrogs-gade 9, P.O. Box 831, DK-2100 Copenhagen Ø (DK).
- (81) Designated States (national): AE, AG, AL, AM, AT (utility model), AU, AZ, BA, BB, BG, BR, BY, BZ, CA, CH, CN, CO, CR, CU, CZ (utility model), CZ, DE (utility model), DE, DK (utility model), DK, DM, DZ, EC, EE (utility model), EE, ES, FI (utility model), FI, GB, GD, GE, GH, GM, HR, HU, ID, IL, IN, IS, JP, KE, KG, KP, KR, KZ, LC, LK, LR, LS, LT, LU, LV, MA, MD, MG, MK, MN,

[Continued on next page]

(54) Title: A BAG FOR COLLECTION OF BODILY FLUIDS

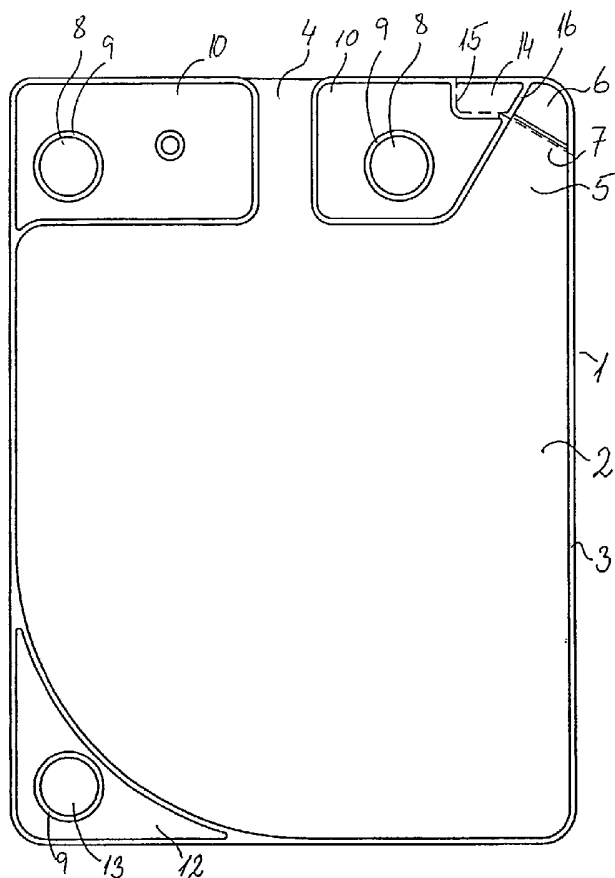

(57) Abstract: The present invention as a bag for collecting bodily fluids such as urine. The bag is adapted for use e.g. in connection with a catheter and is provided with supporting means allowing handling of a liquid-filled bag without squeezing the bag and thus without the risk of contaminating the surroundings. The bag is provided with a draining spout allowing the liquid-filled bag to be emptied without spillage.



WO 03/002043 A2



MW, MX, MZ, NO, NZ, OM, PH, PL, PT, RO, RU, SD, SE, SG, SI, SK (utility model), SK, SL, TJ, TM, TN, TR, TT, TZ, UA, UG, US, UZ, VN, YU, ZA, ZM, ZW.

**(84) Designated States (regional):** ARIPO patent (GH, GM, KE, LS, MW, MZ, SD, SL, SZ, TZ, UG, ZM, ZW), Eurasian patent (AM, AZ, BY, KG, KZ, MD, RU, TJ, TM), European patent (AT, BE, CH, CY, DE, DK, ES, FI, FR, GB, GR, IE, IT, LU, MC, NL, PT, SE, TR), OAPI patent (BF, BJ, CF, CG, CI, CM, GA, GN, GQ, GW, ML, MR, NE, SN, TD, TG).

**Published:**

— without international search report and to be republished upon receipt of that report

*For two-letter codes and other abbreviations, refer to the "Guidance Notes on Codes and Abbreviations" appearing at the beginning of each regular issue of the PCT Gazette.*

## A BAG FOR COLLECTION OF BODILY FLUIDS

### Field of the invention

The present invention relates to a bag for collecting bodily fluids, e.g. for collecting blood  
5 or urine. More specifically, the invention relates to a bag allowing for a hygienic, non-  
contaminating draining of the fluids from a drain into the bag and for subsequent non-  
contaminating emptying of the bag.

### Background of the invention

10 In general, non-drainable bags for collection of bodily fluids such as blood or urine exist.  
Due to the risk of infection, the bags have to be handled with uttermost care, not least in  
hospitals or nursing homes where the risk of cross-contamination leading to infection is  
high. While antibiotics can treat most infections, an infection may be painful for the  
15 patient, it increases the length of the hospitalisation - and adds unnecessary risk to the  
initial disease.

Since the known bags for collection of bodily fluids do not provide suitable means for non-  
contaminating opening of the bags and for controlled draining of fluids therefrom, spillage  
of fluids such as urine or blood can easily occur thereby leading to contamination and  
20 potentially to infection.

The European patent no. 0923398 discloses a catheter assembly comprising a urinary  
collection bag and a catheter. The bag is provided with an elongate pocket for treating the  
catheter with a friction reducing substance prior to the insertion of the catheter into the  
25 urethra. Subsequent to the treatment, the catheter is withdrawn from the tip of the  
elongate pocket and urine is drained into the bag. After catheterisation, the bag may be  
emptied by tearing the urinary bag open. However, spillage and contamination may easily  
occur.

30 The European patent application no. 97901879 discloses a catheter wetting apparatus  
comprising a collection bag for urine. The disclosed bag is provided with one opening in  
the top. The opening is provided in order to allow the user to add a swelling medium for  
preparing a hydrophilic catheter contained in the draining bag. At its other end, the bag  
presents an elongate storage pocket for the catheter, which pocket is in fluid  
35 communication with the collection bag. During use, a swelling liquid, e.g. water is filled  
into the bag. After effectuation of the hydrophilic low friction surface of the catheter, the  
forward most portion of the elongate pocket is torn off and the catheter is manoeuvred  
through the opening and the catheterisation may take place. The spillage of swelling liquid  
incident to this operation causes an unwanted risk of contamination of clothes and the  
40 surroundings. Moreover, there is a severe risk that urine, drained into the bag, escapes  
through a top opening in the bag.

**Description of the invention**

It is an object of the present invention to overcome the above-described disadvantages of the known bags by providing a collection bag for collection of bodily fluids, said bag being made from at least one blank of sheet material and comprising:

5

- a bottom part and a side wall extending upwardly, preferably substantially vertically, therefrom,
- a draining spout, and
- supporting means arranged substantially at the height of, or above the draining spout.

10

The bag could be made from sheets of silicone or from sheets of a thermoplastic elastomeric material, other thermoplastic materials, curable elastomeric materials, polyamide resins or elastomers or any mixture thereof, i.e. the group may comprise materials like PA, PP, PVC, PU, PE, latex and Kraton<sup>TM</sup>. Preferably the bag is made from two sheets, each with a thickness in the range of 15-300  $\mu\text{m}$ ., such as in the range of 50-200  $\mu\text{m}$ . such as in the size of 100  $\mu\text{m}$ . In a preferred embodiment the bag is made from 75  $\mu\text{m}$  PE e.g. Saranex<sup>TM</sup> 650 smooth. The bag may be made of orientated foils.

In order to allow a user to drain fluid from the bag without contaminating the surroundings, the bag according to the present invention is provided with a draining spout. The spout may be formed as a conduit of a length in the range of 10-100mm., such as in the range of 20-80mm., such as in the range of 30-70mm., such as in the size of 40 mm and with a hydraulic radius of at least 6 mm. Preferably, the spout is formed as a channel between non-parallel opposed walls. The channel between opposed walls may be formed e.g. by partly curved or partly straight contour lines. Preferably the angle between the walls is between 15 and 90 degrees. The channel may be defined by the radius of the spout formed by the material between said opposing walls, i.e. the circular radius or, in case the cross section of the spout deviates from circular, the hydraulic radius. Preferably, the radius of the channel decreases from the inside cavity of the bag (at  $r_1$ ) towards the opening of the spout (at  $r_2$ ) which eliminates kinking or diversion of the spout. By observing the decreasing radius, the spout will at any given time remain pointed in the initially intended direction during drainage. The length of the spout is defined as the distance between  $r_1$  and  $r_2$ , and the channel narrows down towards the opening of the spout. The geometry of the spout may be adapted to optimize the draining operation. Typical sizes of  $r_1$  may be from 9-30 mm, preferably 10-25 mm or even 12-19 mm. Typical sizes of  $r_2$  may be 5-15 mm, 6-12 mm or even 7-9 mm. The length  $l$  of the spout defined as the distance between the two radii  $r_1$  and  $r_2$  typically varies between 15-90 mm, 30-70 mm or even 40-60 mm. In one preferred embodiment,  $r_1$  is 12 mm,  $r_2$  is 6 mm, and  $l$  is 33 mm. In another preferred embodiment,  $r_1$  is 19 mm,  $r_2$  is 6 mm, and  $l$  is 52 mm.

40

When pouring fluid out of the bag, a conduit formed as described above will provide a sufficiently well defined flow direction and flow speed to avoid that the fluid uncontrollably flows out of the opening of the spout and for instance down the outer surface of the bag.

However, the spout may simply be defined by a well defined and un-ragged opening in the bag. Moreover, it is an advantage to provide the spout with a non-drip edge by providing a "clean-cut" spout edge without any notches or incisions. In order to enable the user to support the bag during the emptying, and especially during opening of the spout, 5 the spout and supporting means should preferably be arranged substantially at the same height or at least preferably within a vertical distance of 50 mm.

If a liquid-filled bag, especially when formed of a relatively soft sheet material, is lifted, e.g. in order to be emptied, it will easily be squeezed. The pressure thereby created may 10 cause that fluid, upon opening of the bag, squirts out of the opening. In order to allow opening of the bag without incidentally squeezing the bag too hard, the bag is provided with supporting means. The supporting means should allow a user to support or carry the bag without having to squeeze the bag by hand.

15 Due to the gravitational force acting on the fluid, the supporting means may preferably be arranged substantially at the height of or above the draining spout. Thereby, the fluid will be carried away from the spout when the bag is lifted and the spout may therefore easily be opened without risking that fluid is spilled.

20 In order to provide a bag which is not only cheap to produce but which also occupies very little storage space until the time of use, the bag may be formed from 2 layers of sheet material, e.g. one blank of sheet material folded and joined by an edge-joint which encapsulates a storage lumen for storage of the fluid. The sheets may be glued, welded, adhesively bonded or in any other way be joined into a fluidly or liquidly sealed 25 engagement.

The supporting means may preferably be formed by an end zone of at least one of the two layers of sheet material extending beyond the edge-joint, i.e. outside the storage lumen of the bag, the supporting means thus being constituted by a non-liquid-filled part 30 of the bag, i.e. a part of the bag isolated from the storage lumen. Since the supporting means is not liquid filled, the user can get a much safer grip and may squeeze the supporting means without pressing the fluid out of the bag. The supporting means may also be provided in the form of a strap attached as a handle to the top part of the bag. As an alternative a handle may be formed by cutting an incision into the top part of a lumen 35 of the bag, which lumen is isolated from the lumen of the bag wherein the fluid is contained.

In order to allow the user to get a better grip in the end zone, the supporting means preferably comprises a handgrip formed as a gripping area e.g. comprising a through- 40 going supporting hole in the sheet material or at least a weakening line defining a press-out area for the user to make a supporting hole. The through-going hole should preferably be of a size allowing a user to securely grip the bag by gripping through the hole with a finger, even when wearing protective gloves. The hole may therefore preferably be

provided as a substantially circular hole with a diameter in the range of at least 10mm., or the hole should be of any shape with an opening area of at least 75 mm<sup>2</sup>., or the hole could even be provided as a slit, e.g. with a length in the range of 2-4 cm..

- 5 In order to ensure sterility of the bag, the spout may preferably be sealed. When a liquid filled bag is to be emptied, the spout may be opened with a pair of scissors. Consequently, the scissors easily get contaminated. Especially in a hospital or in a nursing home, it may unintentionally happen that such scissors subsequently are used for cutting a bandage or strapping for a wound and the contamination thus accidentally
- 10 spreads. The collection bag according to the invention provides a bag with a spout which is sealed. The spout may be opened without use of any tools, e.g. by tearing off the top part of the spout. The top part of the spout may be torn-off to leave the edge adequately un-ragged, thus allowing for an undisturbed and controllable outflow of the fluid from the bag, by selection of a proper material and sheet thickness for the bag e.g. PVC sheets of
- 15 100 mm thickness.

The spout may also be closed by a detachable closure. According to a simple embodiment, the top part of the spout is torn-off, possibly via a weakened line. Preferably, the weakened line is provided at the edge-joint of the two sheets. In order to allow the

20 user to more easily grab a closure part of the bag and tear that part off, the part to be torn off may comprise a tear-off strip. The part to be torn off may have a lumen which is in fluid communication with the lumen of the bag. Alternatively, since liquid from the bag could otherwise contaminate the interior of the closure part and subsequently even the hands of the person tearing off the closure part, the part to be torn of is situated at the edge of the

25 lumen of the bag.

In order to allow the user to tear the bag open while supporting the bag via the supporting means, the weakened zone of the edge-joint may preferably extend from a point in the vicinity of the supporting means and in a direction away from the supporting means. When

30 tearing the closure part off, tearing in a horizontal direction from the supporting hole influences and stresses the supporting means or the through-going hole least possible. Accordingly, the intended tear line, e.g. a weakened zone of the edge-joint, preferably extends substantially horizontally away from the supporting means and most preferably in an angle between horizontal and vertical downward from a point in the vicinity of the

35 supporting means.

The draining spout may extend in any direction in relation to the bag. However, the most suitable direction for the conduit of the spout is a direction pointing in an upward and outward direction away from the supporting means. Preferably, the draining spout defines

40 an opening with a centre axis which is substantially perpendicular to a centre axis of the supporting hole. As an example, the two sheets constituting the bag may be kept open by means of a tubular piece of plastic, a small wire of a solid material or by similar means for holding the two sheets apart. According to one embodiment, the sheets may be kept apart

in the opening by the use of sheets which, upon tearing off a closure part of the bag, reverts to a non-linear shape. Such sheets can be made by introducing stress in the material which stress is released upon the removal of a closure portion.

- 5 Since occasionally no places for the disposal of the bag is accessible after the emptying of the bag, the closure may preferably be re-connectable in order not to contaminate the surrounding with dribbling liquid from an almost empty bag.

During the emptying procedure, the bag is being held in the supporting means. Tearing off  
10 a closure part of the bag opens the spout. The bag is now rotated until a position is reached wherein the fluid starts to drain out of the spout. In order to facilitate the rotation of the bag, handling means may be arranged at the height of or below the supporting means. The handling means could be constituted by an end zone of at least one of the two layers of sheet material extending beyond the edge-joint, i.e. outside the storage  
15 lumen of the bag, the handling means thus being constituted by a non-liquid-filled part of the bag. Since the handling means is not liquid filled, the user can get a much safer grip and may squeeze the handling means without pressing the fluid out of the bag. The handling means may also be provided in the form of a strap attached to a part of the bag located below the supporting means. The handling means should be provided in a size  
20 allowing for a solid grip, e.g. in the form of a part of the bag which can not be filled with liquid, i.e. isolated from the storage lumen and extending e.g. in the range of 2 - 10 cm. away from the edge-joint and thereby in the order of 2-10 cm. away from the storage lumen. The handling means should preferably extend in a direction of the bag opposite the direction of the conduit of the spout. A through-going hole in the handling means, e.g.  
25 a slit or hole in the sheet material or a weakening line allowing the user to press a hole in the handling means may further improve a firm grip in the handling means and thus support the rotation of the bag during the emptying procedure. The through-going hole should preferably be of a size allowing a user to securely grip the bag by gripping through the hole with a finger, even when wearing protective gloves. The hole may therefore  
30 preferably be provided as a substantially circular hole with a diameter in the range of at least 10mm., or the hole should be of any shape with an opening area of at least 75 mm<sup>2</sup>., or the hole could even be provided as a slit, e.g. with a length in the range of 2-4 cm.

In order to allow a drain, e.g. a catheter or a uresheath to be connected to the bag for  
35 draining the fluid from an individual into the bag, the bag may further be provided with an inlet. The inlet could be a short tubular piece of medical hose or it could be a puncture in the form of a part of the bag being made from an elastic or soft-resilient and preferably thin polymer. When the puncture is punctured with a needle or a catheter, the elasticity of the material ensures a tight seal between the outer surface of that needle or catheter and  
40 the bag.

The inlet may be arranged in extension to the conduit of the draining spout. When the fluid has been drained into the bag through the inlet, the inlet may be removed, e.g. broken or

torn off from the spout and the spout may be used for emptying the bag. The inlet may also be a separately arranged inlet e.g. a tubular piece sealed in between the sheets of foil constituting the bag. According to a preferred embodiment of the invention, the inlet or the bag is provided with a back-flow or anti-reflux valve preventing fluids drained into the  
5 bag from escaping out of the bag through the inlet.

According to a preferred embodiment of the invention, the inlet is a connector hose adapted for non-contaminating withdrawal of a drain to be inserted into a bodily cavity, from the bag. As an example, a catheter may be used as a drain. In one end, the hose  
10 member may be provided with a valve having an open position wherein the hose is in fluid communication with the bag and a closed position wherein the hose is fluidly sealed from the bag. In an opposite end thereof, the hose member may be provided with an outlet adapted for the dismantling of the drain from the connector hose. The connector may preferably be sealed by a detachable closure. The closure may simply be a peelable foil  
15 or it may be a regular closure, e.g. a closure which can be reconnected.

During handling of the bag, the user may want to lay the bag aside. If the bag turns over, there is a risk of contamination with liquids escaping through the inlet or through the spout even if the inlet or spout is sealed by a closure or closing part of the bag. Accordingly, the  
20 bag can present a shape so that, upon filling with a liquid, the bag takes a form wherein the centre of gravity of the liquid filled bag is in a lowermost position. This form will support a stable upright orientation of the liquid filled bag.

According to another aspect, the present invention relates to a drainage assembly  
25 comprising a drain such as a catheter and a collection bag according to the above description. In order to provide a drain which exploits a low friction surface when removed from the package, the assembly may be provided with an amount of a friction reducing substance contained in the connector hose, e.g. water or a similar liquid swelling medium for a hydrophilic coated drain or a lubricating gel. In order to allow non-contaminating  
30 insertion of the drain into a bodily cavity, e.g. into a vein or into urethra, the connector hose comprises an applicator which may be squeezed or bend into engagement with the catheter. The applicator allows the user to manipulate the drain without touching the drain directly by hand. The applicator part of the connector hose may be detachably connected to the other parts of the connector hose or to the bag. Prior to the insertion, the user may  
35 break of the applicator part and use that part to manoeuvre the drain into the bodily cavity to be drained.

### **Detailed description of the invention**

40 Preferred embodiments of the invention will now be described in detail with reference to the drawing in which:

Figs. 1-6 show 6 different embodiments of a collection bag according to the present invention,

Fig. 7 shows a bag according to a preferred embodiment, wherein the shape of the liquid filled bag allows the bag to balance in an upright orientation, and

Fig. 8 shows the bag of Fig. 7 in an opened condition.

Fig. 1, illustrates a collection bag 1 made from two sheets of plastic foil 2, sealed along the assembly line 3. The bag comprises an inlet 4 arranged in the upper part of the bag and a draining spout 5 extending in a direction upwardly and outwardly. The draining spout is sealed by a detachable closure part 6 of the bag. The closure may be re-connectable, but according to a simple embodiment of the invention, the closure part 6 is sealing the bag via a tear-off connection along the broken line 7. As shown in Fig. 1, the tear-off part 6 may preferably be closed towards the lumen of the bag, thus preventing fluid from flowing from the bag and into the tear-off part.

The bag is provided with through-holes 8 strengthened by the assembly lines 9. The through-holes are provided in the supporting flange 10 which is isolated from the lumen 11 of the bag, so that the fluid contained in the lumen of the bag is prevented from flowing into the supporting flange. The flange thereby provides a good support for lifting or holding the liquid filled bag.

The handling means in the form of a handling flange 12 is similarly provided with a through hole 13, enabling the user to empty the bag by supporting the bag in one or both of the supporting hole(s) 8 and by rotating the bag via a grip in the handling through-hole 13. The handling flange is provided with a surface area in the range of 5-10 cm<sup>2</sup> or even more and extends 2-10 cm. or more away from the edge-joint and thus the storage lumen of the bag. Accordingly, the user is able to firmly grip the handling means without incidentally squeezing the bag and thus pressing the fluid out of the bag

The bag is provided with a tear-off flap 14 for tearing the draining spout open. The tear-off flap may be loosely connected to the supporting flange via the tear-line 15. However, the tear-off line is preferably disconnected totally or partly from the supporting means during the production process, so that the flap is only connected to the closure part 6 of the bag via the assembly line 16.

The bag may be produced e.g. by welding or gluing two sheets e.g. of PVC together along the assembly lines 3, 9 and 16. As indicated, the closure part 6 of the bag is preferably isolated from the lumen of the bag, so that the liquid contained in the bag is prevented from flowing into the closure part. Alternatively, the lumen of the closure part may be in fluid communication with the lumen of the bag.

Fig. 2 shows a bag, similar to the bag of Fig. 1 wherein the draining spout is arranged oppositely with respect to the inlet. With this arrangement, the bag must be turned around prior to the emptying. The emptying procedure is as follows: The user seals the inlet 4 and turns the bag around so that the draining spout is in an upward direction, i.e. above the bottom, which bottom is then defined by the edge from which the inlet extends. The bag is held in the supporting means 10, e.g. via the through hole 8, while the draining spout 5 is opened by tearing of the detachable closure 6 via the weakened line 7. The bag is tilted by gripping the handling means 12, e.g. via the through hole 13, which in this orientation of the bag is positioned below the supporting means, and the liquid is emptied out via the draining spout 5.

Fig. 3 shows a bag similar to the bag of Fig. 1 further comprising an inlet tube 31. The tube is sealed to the inlet. Preferably, the tube is provided with coupling means (not shown) for connection of a drain, a catheter or the like. The bag further comprises indication marks 32 indicating the volume of the fluid drained into the bag and a writing field 33 allowing a user to write on the bag with a regular pen. If the bag constitutes a part of a catheter assembly where a friction reducing substance for the catheter is contained therein, the indication marks may have to be adjusted accordingly so that the Indication marks 32 indicates the true volume of liquid, e.g. urine, drained into the bag. The tear-off part of the bag is torn-off via the weakened line 34.

In the embodiment of Fig. 3, the tear-off part of the bag is not sealed towards the lumen of the bag and fluid may thus flow from the bag and into the tear-off part, which in some cases may increase the risk of contamination. However, the embodiment may be desirable in order to keep the manufacturing of the bag simple.

Fig. 4 shows a bag like the one pictured in Fig. 3, but wherein the draining spout is arranged oppositely in relation to the inlet.

Fig. 5 shows the bag of Fig. 3, further comprising a back flow valve 51 preventing back flow of liquids from the lumen of the bag and into the inlet. The tear-off part 52 of the bag may be torn off by the help of the tear-off strip 53. In the embodiment of Fig. 5, no weakened line has been provided. The top part of the spout may be torn-off to leave the edge sufficiently un-ragged, thus allowing for an undisturbed and controllable outflow of the fluid from the bag by selection of proper material and sheet thickness for the bag such as PVC sheets of 100 mm thickness.

Fig. 6 shows the bag of Fig. 4, wherein the draining spout is arranged oppositely in relation to the inlet.

Fig. 7 shows a bag according to a preferred embodiment. The characteristic shape of the bag, a bottom part 71 which is wider than the top part 72, gives an improved balance of the bag both when the bag is lifted in the supporting means 73 and when placed on a

- substantially horizontal surface 74. Due to the shape of the liquid filled bag, the centre of gravity will be defined in a relatively low position, which improves the ability of the bag to balance in an upright orientation when placed on a substantially horizontal surface. The bag is provided with a hose member 75 which is sealed in between the two sheets
- 5 constituting the bag in the upper part 76 of the inlet. The hose member is, in the top part 77 thereof, provided with a closure part 78. Between the upper part of the inlet and the closure part, the hose member may be provided with an applicator for non-contaminating insertion of a drain, e.g. a catheter, into a bodily cavity, e.g. urethra.
- 10 The bellow shaped part 79 of the hose member enables the user to compress the hose member in its longitudinal direction whereby the drain may be pushed out of the hose member. By squeezing or bending the applicator part of the hose member, the user may fixate the drain or catheter inside the applicator part of the hose member so that the drain or catheter can be inserted directly from the hose member without touching it by hand.
- 15 The applicator part of the hose member may be dis-connectable from the hose member, allowing easier handling of the drain or catheter. The hose member shown in Fig. 7 is provided with a break-off weakened zone 80 allowing the applicator part of the hose member easily to be broken off from the bag. The handle means 81 allows easy emptying of the liquid through the spout 82. The spout can be defined as a channel with a hydraulic
- 20 radius in the link between the bag and the spout ( $r_1$ ) and a hydraulic radius at the outlet of the bag ( $r_2$ ). The length of the spout is the distance ( $l$ ) between the two hydraulic radii. The spout is closed by a closure part 83. The closure part may easily be torn off without the use of any tools, by gripping the tear-off strip 84 and by pulling in a substantially
- 25 direction away from the supporting means or alternatively pulling in a downward direction away from the supporting means. The tear-off strip may be attached to the upper part - the supporting part - of the bag through the tear-line 85. However, the entire closure part of the bag including the tear-off strip may also be connected to the bag only through the tear-off line 86.
- 30 As shown in Fig. 8, the closure part 83 may, after the opening of the bag, be held connected to the bag, e.g. by ending the tear-line 85 shortly before (but in the vicinity of) the edge 87 of the bag. Preferably, the tear-line extends downwards, parallel to the edge 87 in the close vicinity to the edge. Thereby, the user may tear the closure part in a
- 35 remain in connection with the bag without disturbing the draining of liquid substances from the bag.

## Claims

1. A collection bag for collection of bodily fluids, said bag being made from at least one piece of sheet material and comprising:  
5  
- a bottom part and a side wall extending upwardly therefrom,  
- a draining spout, and  
- supporting means arranged substantially in the height of, or above the draining spout,
- 10 2. A collection bag according to claim 1, wherein supporting means is formed by an end zone of at least one of the 2 layers of sheet material extending beyond the edge-joint.
3. A collection bag according to any of the preceding claims, wherein the supporting means comprises a handgrip formed as a through-going supporting hole in the sheet  
15 material.
4. A collection bag according to any of the preceding claims, wherein the spout is sealed.
5. A collection bag according to claim 4, wherein the closure is connected with the bag  
20 allowing the closure to be torn off.
6. A collection bag according to claim 5, wherein the part to be torn of comprises a tear-off strip.
- 25 7. A collection bag according to claim 5 or 6, wherein a weakened zone extends from a point in the vicinity of the supporting means and in a direction away from the supporting means.
8. A collection bag according to any of claims 3-7, wherein the draining spout defines a  
30 draining conduit extending in a upward and outward direction substantially perpendicularly to a centre axis of the supporting hole.
9. A collection bag according to any of the preceding claims, further comprising handling means arranged at the height of or below the supporting means.  
35
10. A collection bag according to claim 9, wherein the handling means is formed by an end zone of at least one of the 2 layers of sheet material extending beyond the edge-joint.
11. A collection bag according to claim 9 or 10, wherein the handling means comprises a  
40 handgrip formed as a through-going hole in the sheet material.
12. A collection bag according to any of the preceding claims, further comprising an inlet.

13. A drain assembly comprising a drain and a collection bag according to any of the claims 1-12.

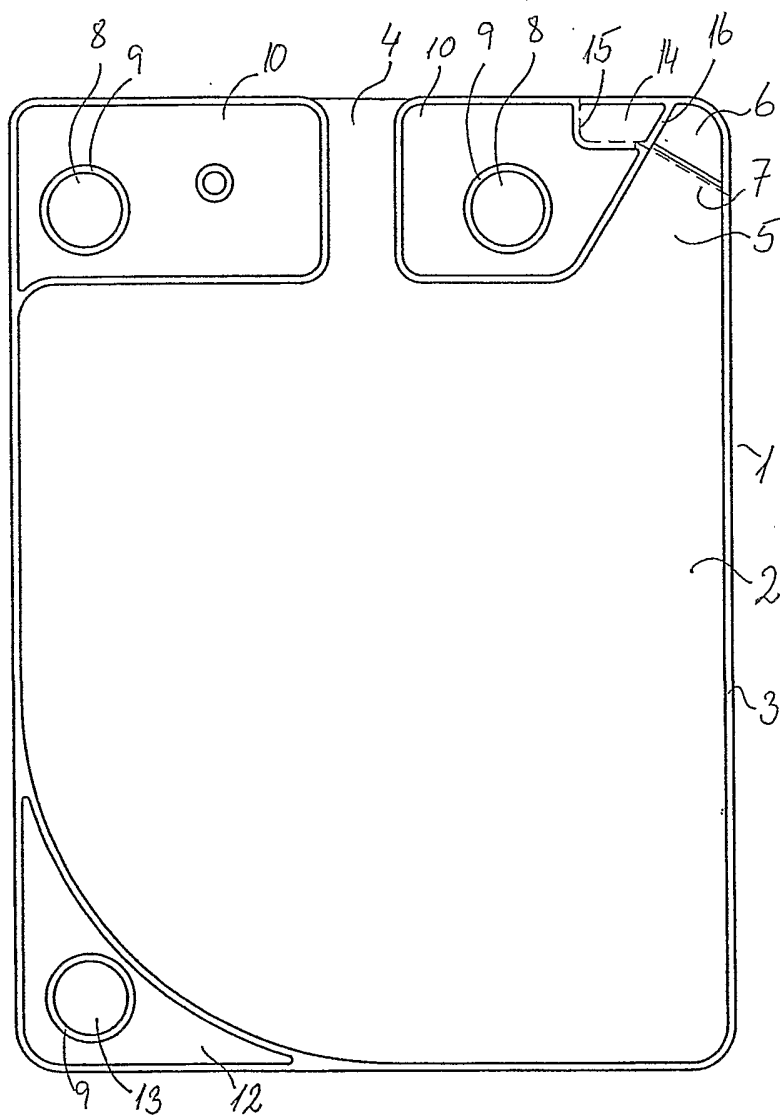

Fig. 1

2/8

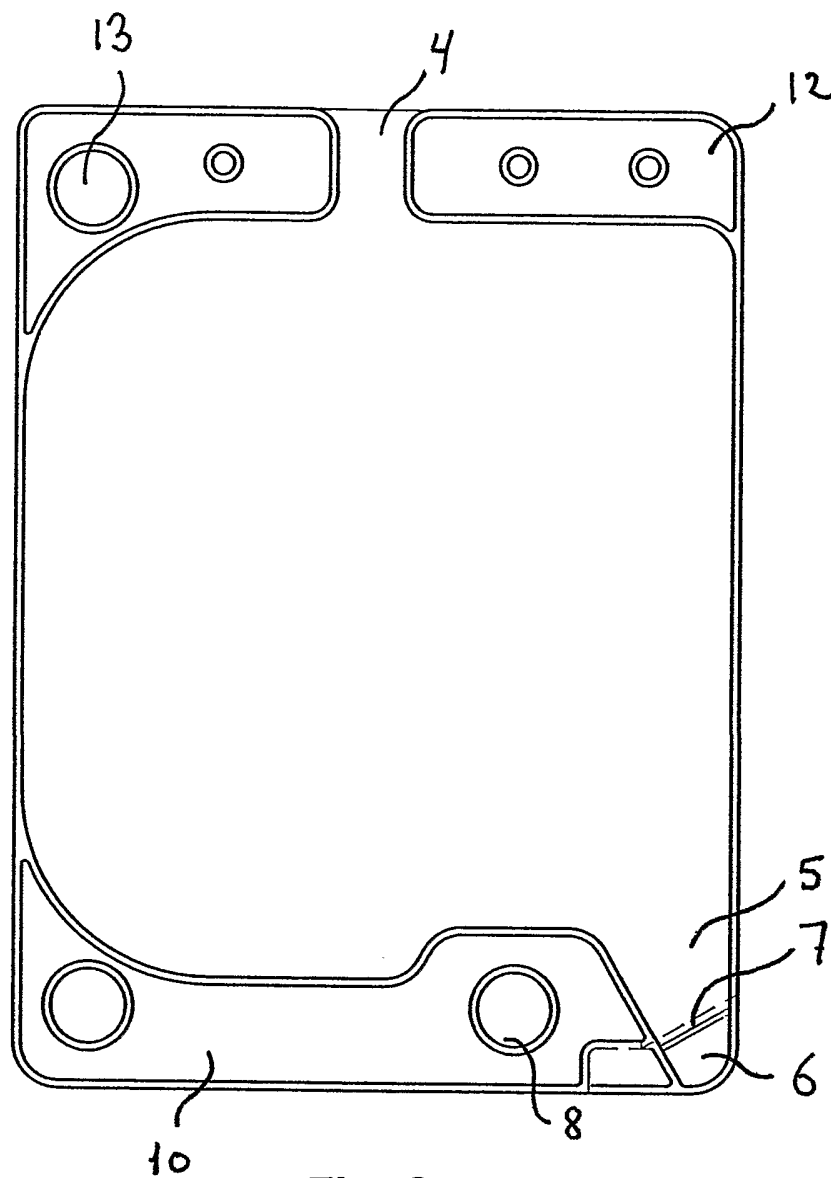

Fig. 2

3/8

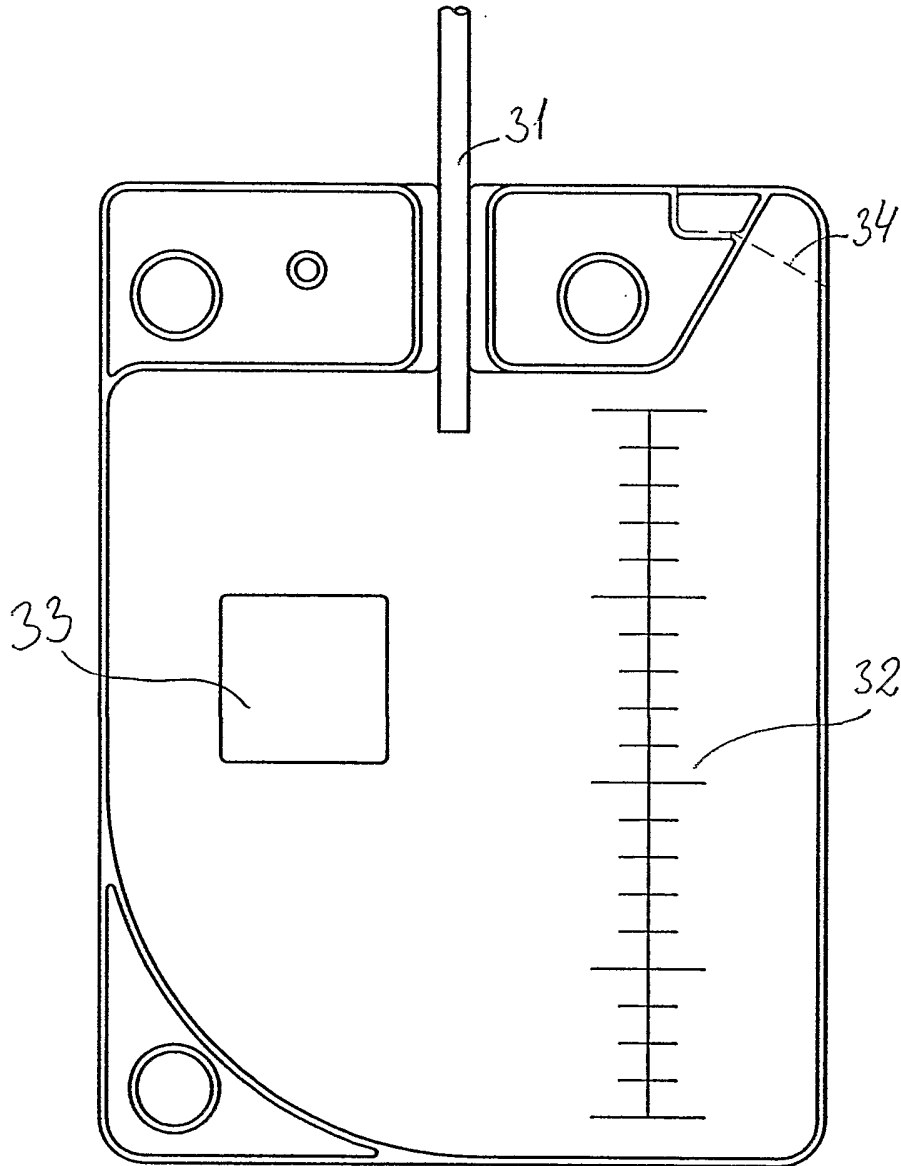

Fig. 3

4/8

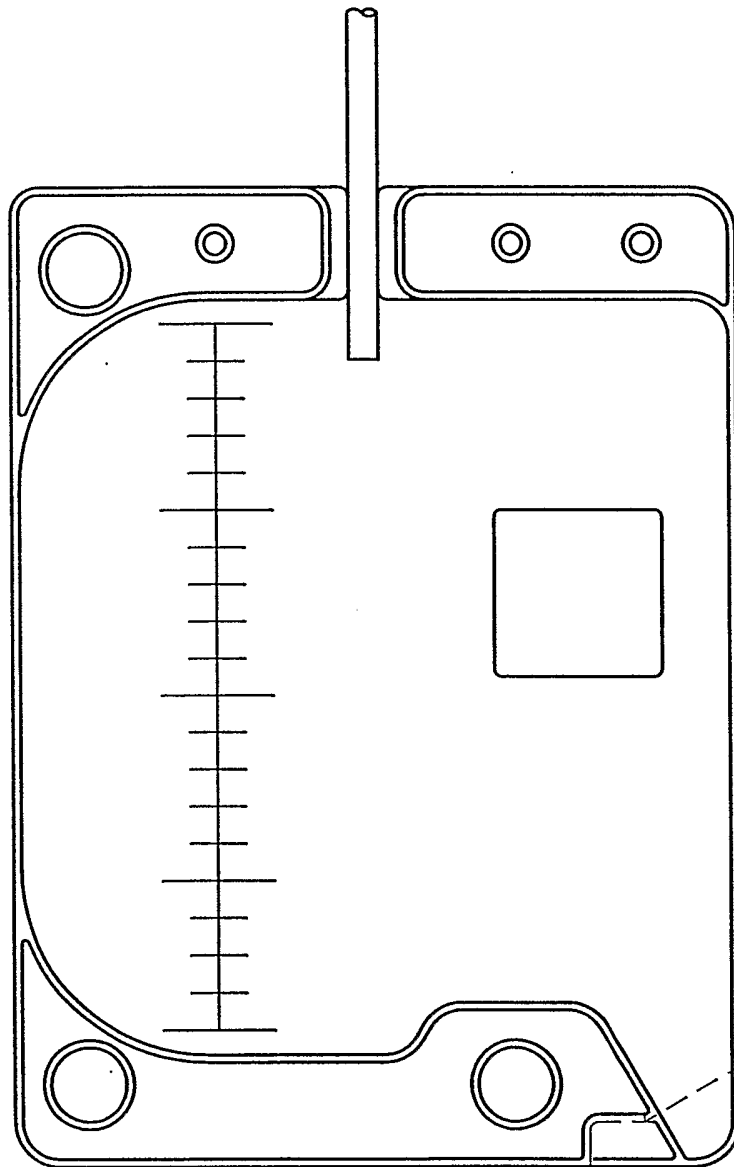

Fig. 4

5/8

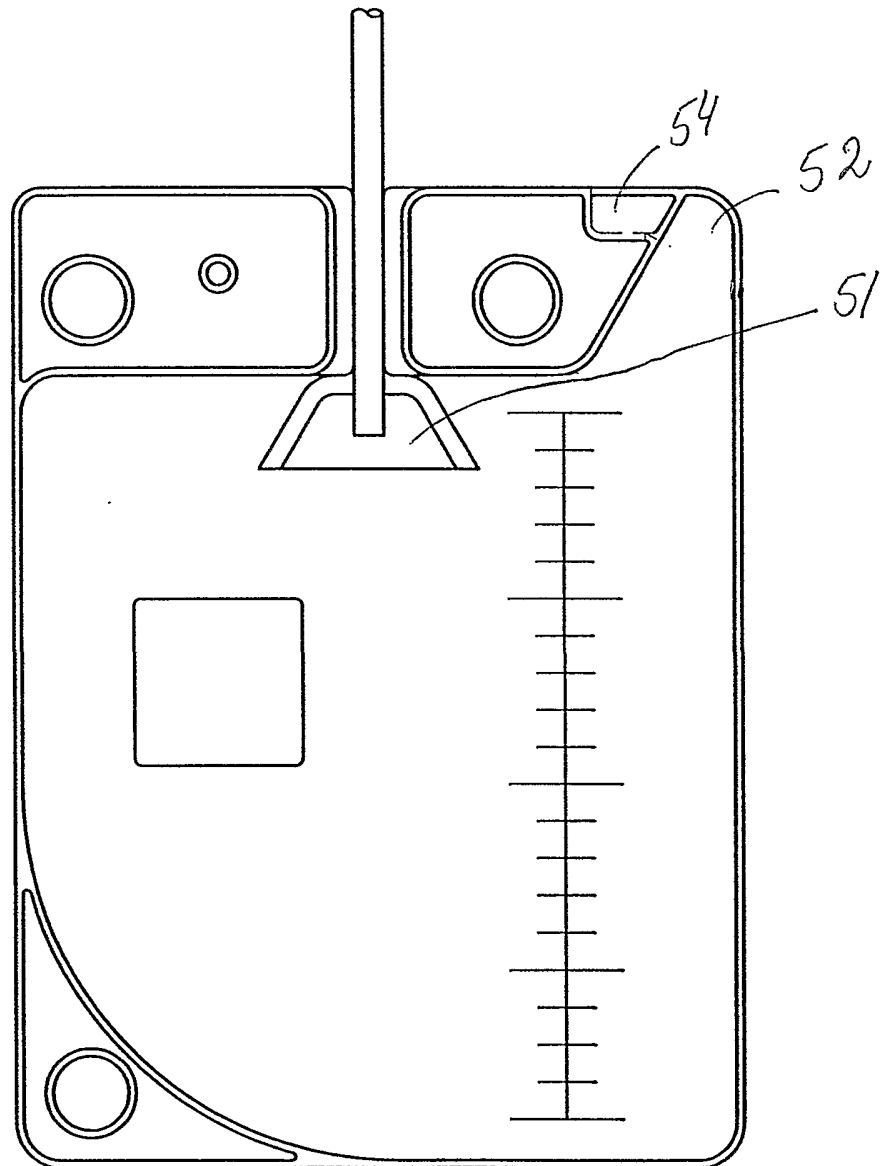

Fig. 5

6/8

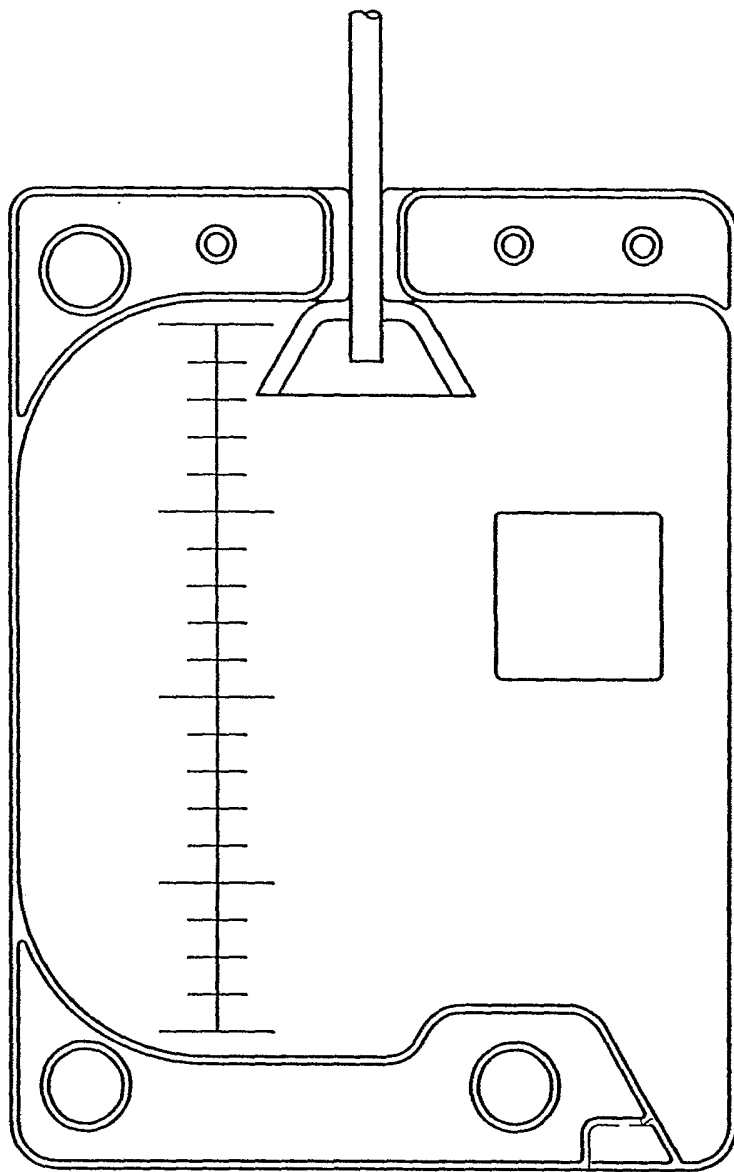

Fig. 6

7/8

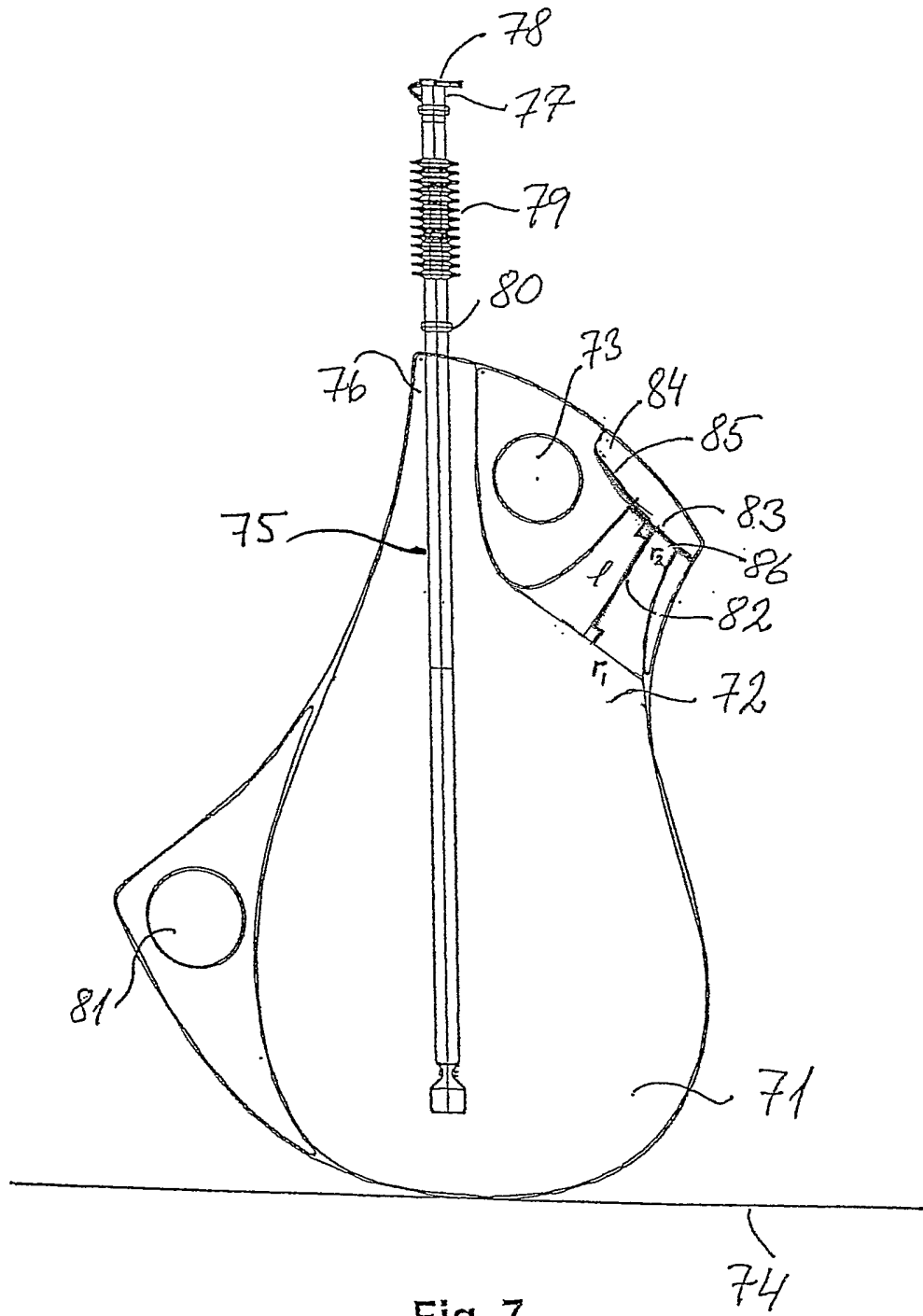

Fig. 7

8/8

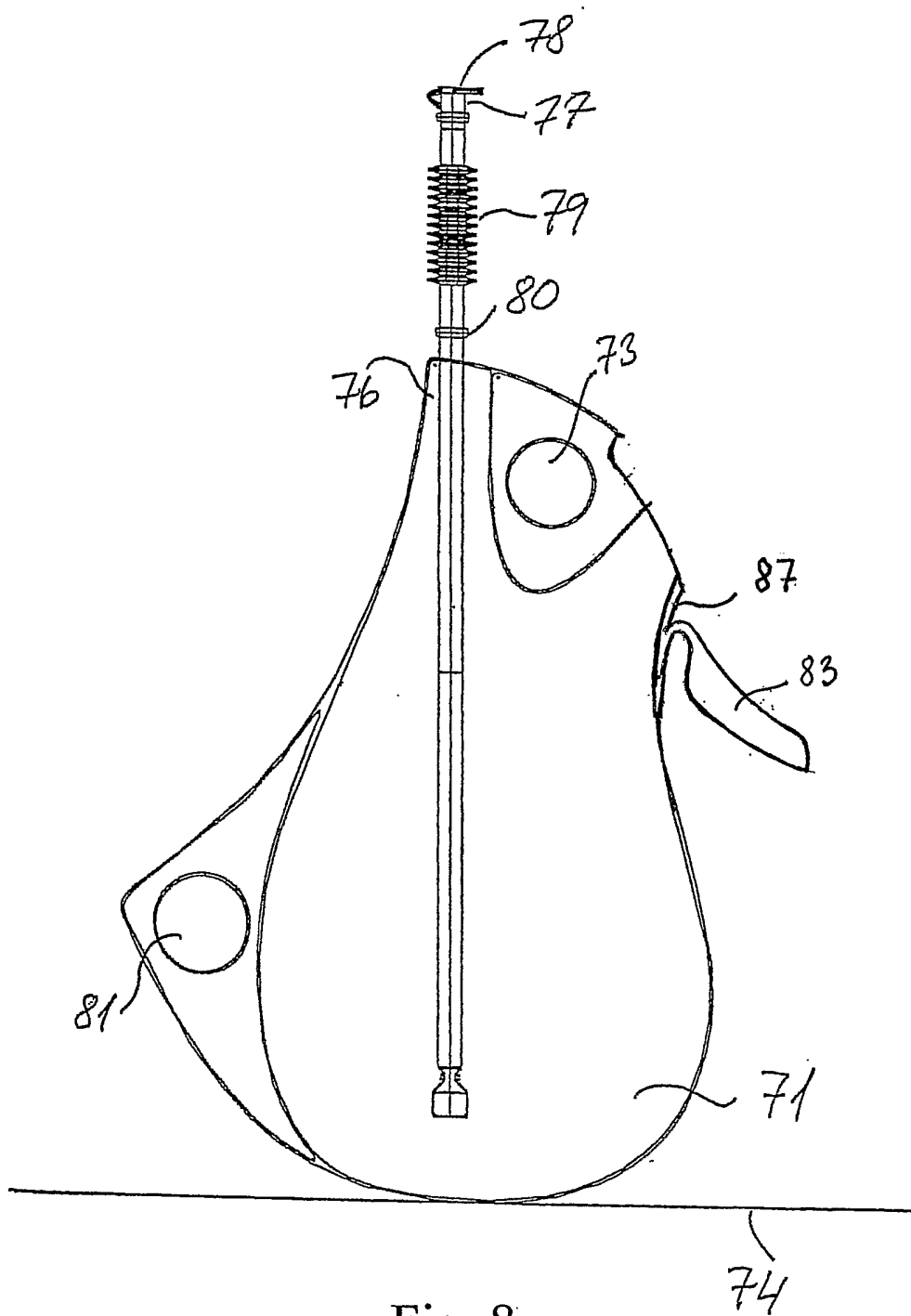

Fig. 8