



(12) EUROPEAN PATENT APPLICATION

(43) Date of publication:
03.05.2006 Bulletin 2006/18

(51) Int Cl.:
B65D 71/00 (2006.01)

(21) Application number: 06001980.9

(22) Date of filing: 11.01.1996

(84) Designated Contracting States:
AT BE CH DE DK ES FR GB GR IE IT LI LU MC NL
PT SE
Designated Extension States:
LT LV SI

(72) Inventor: Auclair, Jean Michel
36000 Chateauroux (FR)

(30) Priority: 10.01.1995 GB 9500428

(74) Representative: Hepworth, John Malcolm et al
HLBBshaw
Bloxam Court
Corporation Street
Rugby,
Warwickshire CV21 2DU (GB)

(62) Document number(s) of the earlier application(s) in
accordance with Art. 76 EPC:
99111727.6 / 0 950 617
96903421.4 / 0 800 479

Remarks:

This application was filed on 31 - 01 - 2006 as a
divisional application to the application mentioned
under INID code 62.

(71) Applicant: MeadWestvaco Packaging Systems
LLC
Stamford,
Connecticut 06905 (US)

(54) Wrap-around carton

(57) A carton for packaging a plurality of articles, which carton comprises a first panel (118,218,330) having a corner; a second panel (114,214,316) neighbouring said first panel, adjacent edges of said first and second panels being disposed to converge on said corner; and a gusset (138,338) extending between said adjacent edges and foldably connected to said first and second panels along said adjacent edges, said gusset comprising a pair of gusset panels (158,160,358,360) interconnected along a fold line, characterised in that said first panel has an end panel (128,228,328) foldably connected thereto, and one (158,358) of said gusset panels comprises means (159,359) for operably abutting said end panel to help retain said second panel in a formed position upon formation of said carton.

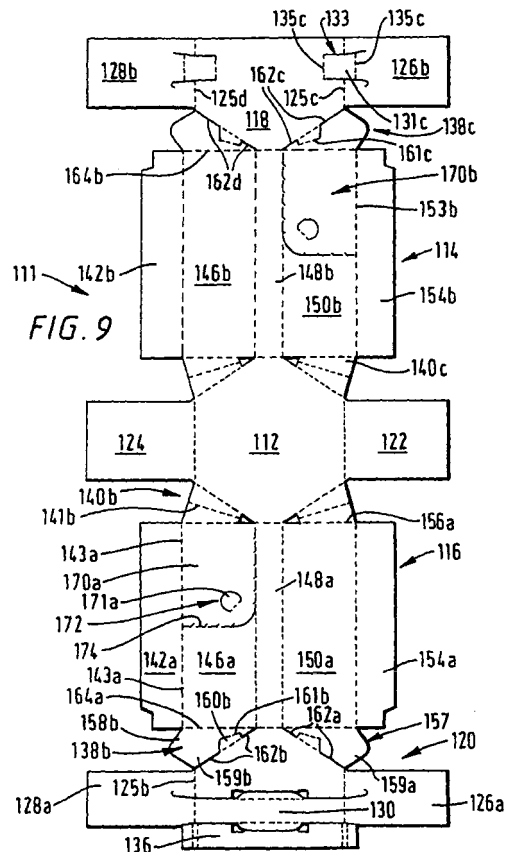

Description

[0001] The invention relates to cartons for packaging a plurality of articles such as cans or bottles of drink for example, particularly cartons for packaging multiple tiers, or layers, of articles in a fully enclosed carton for example, and also cartons for packaging articles in a non-rectangular array.

[0002] More particularly, the invention relates to a gusset arrangement comprising two gusset panels in a corner structure of a carton wherein one of the panels has an aperture provided therein. It is known to provide a corner structure with a gusset arrangement comprising two panels. One example of gusset arrangement is disclosed by Stout et al. in US 5 221 041 which has a gusset panel with a cutaway portion being formed therein.

[0003] A further gusset arrangement for use in the corner structure of a strawberry tray is disclosed by Hamilton in US 3 102 674. The arrangement consists of two foldably interconnected gusset panels wherein a tab connected to one gusset panel is cut from the other gusset panel, the tab being used to provide a greater surface area for gluing when the blank is erected to form a tray.

[0004] The invention seeks to avoid or at least mitigate various problems with prior art cartons.

SUMMARY OF INVENTION

[0005] A first aspect of the present invention provides blank for forming a carton for packaging a plurality of articles comprising a first panel having a corner; a second panel neighbouring said first panel, adjacent edges of said first and second panels being disposed to converge on said corner; and a gusset extending between said adjacent edges and foldably connected to said first and second panels along said adjacent edges, said gusset comprising a pair of gusset panels interconnected along a fold line, characterised in that said first panel has an end panel foldably connected thereto, and one of said gusset panels comprises means for operably abutting said end panel to help retain said second panel in a formed position upon formation of said carton.

[0006] Preferably, wherein said second panel comprises an end panel portion and a medial panel portion foldably connected together by a fold region so that upon formation of said carton, said second panel is folded to said formed position where said end and medial panel portions are put into at least two different planes to conform with a shape of said first panel.

[0007] Preferably, wherein said first panel is non-rectangularly shaped

[0008] Preferably, wherein said abutting means is provided by said one gusset panel.

[0009] Preferably, wherein said abutting means comprises a tab protruding from said one gusset panel away from said corner.

[0010] Preferably, wherein said abutting means comprises an edge of said tab.

[0011] A second aspect of the present invention provides a carton for packaging a plurality of articles comprising a first panel having a corner; a second panel neighbouring said first panel, adjacent edges of said first and second panels being disposed to converge on said corner; and a gusset extending between said adjacent edges and foldably connected to said first and second panels along said adjacent edges, said gusset comprising a pair of gusset panels interconnected along a fold line, characterised in that said first panel has an end panel foldably connected thereto, and one of said gusset panels comprises means for operably abutting said end panel to help retain said second panel in a formed position upon formation of said carton.

[0012] Preferably, wherein said second panel comprises an end panel portion and a medial panel portion foldably connected together by a fold region so that upon formation of said carton, said second panel is folded to said formed position where said end and medial panel portions are put into at least two different planes to conform with a shape of said first panel.

Preferably, wherein said first panel is non-rectangularly shaped

[0013] Preferably, wherein said abutting means is provided by said one gusset panel.

[0014] Preferably, wherein said abutting means comprises a tab protruding from said one gusset panel away from said corner.

[0015] Preferably, wherein said abutting means comprises an edge of said tab.

[0016] Embodiments of the invention will now be described, by way of example only, with reference to the accompanying drawings, in which: -

FIGURE 1 is a plan view of a carton blank for forming a carton according to a first embodiment of the invention;

FIGURE 2 to 6 provide different views of the blank shown in Figure 1 during the process of forming the carton shown in Figures 7 and 8;

FIGURES 7 and 8 are perspective views of a formed carton according to the first embodiment of the invention;

FIGURE 9 is a plan view of a blank for forming a carton according to a second embodiment of the invention;

FIGURES 10 to 14 are perspective views of a carton according to the second embodiment of the invention;

FIGURE 15 is a plan view of a blank for forming a carton according to a third embodiment of the invention;

FIGURES 16 to 21 are various perspective views of a carton according to a third embodiment of the invention;

FIGURE 22 is a plan view of a blank for forming a fourth embodiment of a carton according to the invention;

FIGURES 23 to 28 provide views of different stages during the process of forming a carton from the blank shown in Figure 22;

FIGURE 29 is a perspective view of a carton formed from the blank shown in Figure 22; and

FIGURE 30 is a schematic representation of the method of loading and closing the carton shown in Figure 29.

[0017] The first embodiment of the invention is shown in Figures 1 to 8 wherein a carton blank 11 for forming a carton 10 shown in Figures 7 and 8. The carton is designed to hold a non-rectangular array of articles such as an array comprising rows of 2, 3 and 2 articles which has a substantially hexagonal cross-section in the horizontal plane. However since articles such as cans and bottles are generally cylindrical or at least have curved sides in the case of bottles, a hexagonal array of such articles has curved corners. In order to tightly pack such an array, carton 10 has curvable side panel portions. Carton 10 can hold a single tier of tall articles or a double tier of articles. Of course multiple tiers can be accommodated simply by adapting the length of its side panels to suit the height of the proposed number of tiers.

[0018] The blank 11 comprises a base panel 12 which is hingably connected to end tabs 22 and 20 and to side panels 14 and 16 via fold lines 56a and 56b, and gusset panels 40a, 40b, 40c and 40d as shown in Figure 1. Side panels 14 and 16 each comprises a series of side panel portions 42a and 42b, 46a and 46b, 50a and 50b, and 54a and 54b. The side panel portions are separated from adjacent side panel portion by curvable panel portions 44a and 44b, 48a and 48b, and 52a and 52b. The curvable panel portions comprise a series of crease lines which allow some amount of bending of each of the curvable panel portions in order for the side panels 14 and 16 to be folded around packaged articles in an arcuate manner thereby to fully enclose the sides of the carton. The carton therefore has a cross-section in the horizontal plane which is polygonal, in this case hexagonal, with curved, or rounded, corners.

[0019] Side panels 14 and 16 are hingably attached to first and second top panels 18 and 20 respectively. The top panels 18 and 20 are hingably connected to respective side panels 14 and 16 by gussets 38a, 38b, 38c and 38d and fold lines 64a and 64b. The top panels are of the lap type and can be joined together using adhesive or cooperating locking means such as tabs and aper-

tures, for example. Top panel 18 comprises end tabs 26b and 28b hingably connected thereto along fold lines 25c and 25d respectively. Slit features 33c and 33d are positioned at the fold line between the first top panel 18 and each of the end tabs 26b and 28b but in other embodiments only one or no such features might be provided. These slit features 33c and 33d enable bending of the fold line between the side tabs and first top panel when handle 30 is used as described later. Handle 30 is provided in second top panel 20 and comprises a strap having finger tabs 32 foldably joined thereto. Second top panel 20 is foldably connected to end tabs 26a and 28a along fold lines 25a and 25b respectively and, in this example, the ends of the handle strap extend into end tabs 26a and 28a along lateral cuts 33a and 33b.

[0020] Second top panel 20 also comprises a handle reinforcement panel 36 which, in this example, is hingably connected to the strap of handle 30 along fold lines 34.

[0021] Each of the gussets 38a, 38b, 38c and 38d can, as shown in Figure 2, comprises an outermost panel 58 hingably connected to an innermost panel 60. A cut 62 can be used to separate part of panel 58 from panel 60 and the associated top panel 18 or 20. Thus cut 62 can usefully define a protrusion 59 from outermost gusset panel 58 which protrusion 59, or folding means, can be used to tuck the gusset inside the carton and hence help the folding of the sides of the carton. Lower gussets 40a, 40b, 40c and 40d could be formed similar to gussets 38 but here each comprises two symmetrical panels which are hingably connected to one another along a fold line 41.

[0022] A method of folding blank 11 to form a completed carton 10 as shown in Figures 7 and 8, can be seen in Figures 2 to 6. First top panel 18 can be first folded about fold line 64b so that it is overlaid on side panel 14. Reinforcement panel 36 can then be folded about fold line 34 beneath handle strap 30 thereby to provide a two-ply handle and thus strengthen the handle. Side panels 16 and second top panel 20 can then be folded about hinge line 56a into the configuration shown in Figure 3. The first and second top panels can then be attached to one another for example by gluing at overlapped portions, or using cooperating locking means (not shown) such as locking tabs and apertures. Of course, other panels could be used as overlap panels to enable a tubular sleeve to be formed.

[0023] The handle edges at cuts or slits 33a and 33b are thus substantially aligned with slit features 33c and 33d in first top panel 18 in order to allow parts of the hinge or fold lines 25a, 25b, 25c and 25d between the top panels and end tabs 26a and 28a, and 26b and 28b to move. This enables upward flexing of the handle strap 30 in use by allowing inward movement at the portion of the handle strap adjacent the ends of the carton. To assist in this movement, a pair of lateral creases or fold lines 35c and 35d can be provided for example in the first top panel 18 as shown in Figure 2. In this example both the fold lines 35c and 35d, and associated parts of fold lines 25c and

25d which extend across the deflectable portion which extends between the end tab and the top panel assist in the inward deflection thereof when handle 30 is used.

[0024] The folded blank can then be opened to form a sleeve like structure as shown in Figure 4. In this configuration, articles such as cans can be loaded into a partially formed carton 10 through the open ends thereof.

[0025] After loading the articles, the end tabs 22 and 24 can be folded upwardly whilst end tabs 26a, 26b, 28a and 28b can be folded downwardly. The side panel 14 and 16 can then be folded around the articles to close the ends of the carton.

[0026] For example, gussets 38a, 38b, 38c and 38d can be folded into the position under the associated top panel 18 or 20 by pressing inwardly the panel 58 and/or the panel 60 of one or more of the gussets 38. By folding the gussets 38a to 38d inwardly, the ends of the side panels 14 and 16 are caused to close about the ends of the carton 10.

[0027] Similarly, by folding gussets 40a to 40d inwardly of the carton 10, the lower part of side panels 14 and 16 can be caused to rotate to close the ends of the carton.

[0028] Associated endmost portions of side panels 14 and 16 are thus brought into an overlapping relationship with each other as shown in Figure 7. To maintain the carton in its closed configuration, endmost portions 54a and 54b can be attached to one another, for example by gluing or by cooperating locking means such as locking tabs and apertures. Also, either one or both of the endmost portions 54a and 54b can be attached to either one or both of end tabs 26a and/or 26b or end tab 22. Thus, various overlapping portions can be attached together. Similarly the opposite end of the carton can be maintained in a closed position so as to form the fully enclosed carton 10 shown in Figures 7 and 8.

[0029] It can be seen that carton 10 is designed to fully and tightly enclose an array of articles by having curvable side panels which wrap tightly around the articles. The carton is made aesthetically pleasing by having suitably shaped top and bottom panels which reflect the non-rectangular shape of the stored array of articles.

[0030] Of course, other non-rectangular arrays such as triangular, rhombic, rhomroidal, and octagonal arrays for example could be used.

[0031] A second embodiment of a carton 110 according to the invention is shown in Figures 9 to 14. In this embodiment, features substantially similar to those shown in the first embodiment are labelled using the same two digit reference numeral prefixed by the numeral 1. Thus, a first top panel 118 is hingably connected to a side panel 114 which in turn is hingably connected to a base panel 112. The base panel 112 is connected to a second side panel 116 which is hingably connected to a second top panel 120. In this example, handle slots 133 are substantially similar to those in the previous embodiment, however, fold lines 135c can be provided to define a displaceable portion 131c adjacent the fold lines 125c and 125d between top panel 118 and end panels 126b

and 128b respectively.

[0032] Alternatively, those lines labelled 135c can be cut lines thereby providing an aperture 131c at the fold lines between the first top panel 118 and end panels 126b and 128b.

[0033] In the side panels 114 and 116, the central curvable portions of the first embodiment are replaced by a central panel portion 148a and 148b and the other side panel portions can be simply hingably connected by a single fold line. In this embodiment, the side panels are also adapted to wrap around the sides of an array of articles to fully enclose the sides thereof. However, the base panel 112 and carton top panel, formed from panels 118 and 120, do not comprise overly rounded corners, but each is an irregular octagon. In this example an array of articles with rows of 1, 2, 2 and 1 articles is intended to be placed in the or each tier. The blank 111 shown is adapted to hold two tiers of such arrays of cans for example.

[0034] The side panels are hingably connected to the associated top panel by gussets 138 which can each comprise a main panel 158 for example hingably connected to the associated side panel 114 or 116 and minor panel 160 hingably connected to both the main gusset panel 158 and the associated top panel 118 or 120. An interrupted cut 162 can be used to separate part of panel 158 from panel 160 and the associated top panel 118 or 120. Thus cut 162 can usefully define a protrusion 159 which can be used to tuck the gusset 138 into the position between the associated top panel 118 or 120 and the articles within the carton 110. In other words, the shape of the gusset panels is designed to assist in the folding of the side panels during the closing of the carton after loading. Also, an edge 157, here provided on each of the main gusset panels 158, cooperates in the formed carton with an end panel 126 or 128 to retain the formed shape of the side panels.

[0035] The side panels 114 and 116 here each comprise removable portions 170a and 170b. These portions can be attached to the carton blank in part at least along a tearable line 174 and by fold lines 153 and 156 or 164 as shown in Figure 9. The removable portions 170 can comprise means to assist in the removal of the portion from the carton such as a finger aperture 172. The finger aperture can be closed by a hingable tab portion until it is used.

[0036] Carton 110 can be formed by folding blank 111 in a manner substantially similar to that described with reference to the first embodiment. Thus top panel 118 can be folded about fold line 164b, side panel 116 and top panel 120 can be folded about fold line 156a and the top panels attached to one another at overlap portions thereof.

[0037] A carton sleeve can then be formed and loaded prior folding side panels 114 and 116 round and closing the ends by folding end panels 122, 124, 126a, 128a, 126b and 128b about their associated fold lines.

[0038] Beneficially, the openable portions 170 enable

an article A to be removed from carton 110 without tearing open the entire carton. As shown in Figures 11 and 12, openable and closeable portion 170b can be opened by breaking the tearable line 174 and opening the panel 170b about fold line 153b. Additionally, a tear line 161c can be provided in gusset 138c between gusset panels 158c and 160c (see Figure 9) to enable openable panel 170b to be fully opened.

[0039] As can be seen in Figure 12, carton 110 can package two tiers of articles which can be separated by a partition panel 176 for example. In order to gain access to the lower tier of articles, a second openable or removable portion 170a can be provided. In order to open openable portion 170a it is folded about hinge line 143a whilst breaking tearable feature 174 and tearable fold line 141b between the panels of gusset 140b (see Figure 9). Of course, the gussets could be designed to enable the openable panels to be fully opened without the need of a second tearable feature such as lines 161c or 141b just described.

[0040] Additionally, in this example, the gusset panels 138 are folded beneath the associated upper panel by folding gusset panels 158 and 160 relative to one another about fold line 161 so that both portions are superposed beneath the top panel. The main gusset panel 158 can thus lie adjacent a fold line 125 between end panels 126a, 126b, 128a or 128b at edge 157 thereof thereby to provide rigidity at this fold line between the side panels and up to the edge of the handle strap as well as acting to retain the shape of the side panels.

[0041] A third embodiment of a carton according to the invention will now be described in relation to the blank and carton shown in Figures 15 to 20. In this example of the invention, features similar to those of the first two embodiments are labelled using the same last two digit reference numeral prefixed with the numeral 2. Thus, a first top panel 218 is hingably connected to a side panel 214 which in turn is hingably connected to a base panel 212. A second side panel 216 is hingably connected to both base panel 212 and a second top panel 220. The side panels 214 and 216 are substantially similar to those shown in Figure 9 as described above, except the openable (and/or removable) portions 270 have a different configuration. In this example, a tearable line 274 extends substantially about three sides of the rectangular panel forming removable portion 270. The openable portion 270a and 270b are hingably connected on a fourth side along fold lines 239b and 237c respectively. Each of these fold lines connects the openable portions 270a and 270b to an associated gusset panel namely 240b and 238c respectively in this example. A finger aperture 272 can be provided and this can be covered by a foldable tab 271.

[0042] Openable portion 270b is foldable about fold line 237c in the completed carton as shown in Figure 17. The portion 270b can be removed by tearing along fold line 261c as shown in Figure 18 thereby to leave a carton wherein the articles A in an upper tier are removable as

shown in Figure 19. Similarly, lower openable portion 270a is openable by folding about fold line 239b. Also, the portion 270a can be removed entirely by tearing along fold line 241b for example.

[0043] In this example the carton 210 is adapted to hold two tiers of articles, wherein each tier comprises an array of 1, 2, 2 and 1 rows of articles. Of course, different numbers of rows of different numbers of articles could be packaged and indeed different numbers of tiers can be housed by suitably adapting the blank described here.

[0044] A fourth embodiment of a blank 311 and of a carton 310 formed therefrom as shown in Figures 22 to 30.

[0045] The formed carton 31 shown in Figure 29 has a generally octagonal cross-section in the horizontal plane and is designed to accommodate a single tier of articles such as bottles in an array of 3, 4, 4, and 3 articles per row.

[0046] Blank 311 comprises a top panel 320 which is hingably connected to side panel 316 along fold line 364a.

[0047] In turn, the side panel 316 is hingably connected to base panel 312 having an octagonal shape. The base panel 312 is connected to a second side panel 314 along a fold line 356b. In this embodiment, instead of providing overlapping top panels to form the blank into a tubular, sleeve like structure, a tab 315 is provided. In this embodiment tab 315 which is hingably connected to the top panel 320 along a fold line 364b can be attached to an upper portion of side panel 314 for example by gluing or by using cooperating locking means such as locking tabs and apertures.

[0048] Blank 311 comprises a handle 330 having finger tabs 332 in the top panel 320 and a handle reinforcing strap 336, which here is hingably connected to the end panels 326 and 328 which are hingably connected to the top panel 320. Additionally, diverging crease lines can be formed in the top panel 320 to provide a stress relieving feature 380 for when the handle is used. In this embodiment, openable features 370 are provided in the top panel 320.

[0049] The openable features 370 about the aperture defined by the finger tabs 332 which form part of the handle 330 and have lateral tearable lines similar to lines 274 and 174 shown in the second and third embodiments described herein. Four gussets 338 are provided between the top panel 320 and effectively the side panels of the carton when tab 315 and side panel 314 are attached. The gussets 338 are equivalent in this example and with reference to gusset 338a it can be seen that they comprise a main panel 358a which is hingably connected to side panel 316. The main panel 358a is hingably connected to a minor panel 360a which in turn is hingably connected to top panel 320. The main gusset panel 358a comprises a protruding tab 359a which can be used to close the carton and to retain the associated side wall in a curved formation due to cooperation between the edge 357a of tab 359a and end panel 328 for

example. This cooperation is more apparent with reference to the later drawings. Also, the gusset panel 358 can be positioned between an associated, e.g. comermost, article top such as a bottle cap and the top panel 320.

[0050] This can help prevent any aperture opening in the top of the carton when formed in spite of the aperture 363 formed adjacent the gusset.

[0051] The side walls 316 and 314 are symmetrical and comprise a main central panel having a medial fold line 385a and 385b respectively which enable both side panels to be folded substantially in half. This is beneficial in enabling the partially formed carton shown in Figure 25 to be flat packed ready for erection into the sleeve like structure shown in Figure 26 which is ready for loading.

[0052] The medial fold lines 385a and 385b extend into side panel portions 346a, 350a, 346b and 350b. Additionally, a gusset 386 is provided adjacent each fold line 385 in the lateral portions of the side panels. These gussets 386 facilitate better wrapping of the sides and ends of loaded articles and the formation of a sloping upper portion of the side panels which can be seen with reference to Figures 27 to 29. To this end fold lines 323a and 323b are also provided in lower end panel 324 and 322 respectively. In order to form the sloping upper portion it is apparent that top panel 320 should be a smaller octagon than base panel 312.

[0053] Additionally, in common with the other embodiments, gussets 340 can be provided between base panels 312 and the side panel.

[0054] In order to form carton 310 the reinforcing strip 336 is folded about fold line 334 into position shown in Figure 23. Thus, apertures 382 in strip 336 are aligned with fold lines 325a and 325b thereby minimising any restriction in the folding of the upper end panels 328 and 326 about fold line 325a and 325b when closing the ends of a loaded carton. Next, the top panel 320 and upper portion of side panel 316 are folded about fold line 385a into the position shown in Figure 24. The upper portion of side panel 314 is then folded about fold line 385b so that it abuts tab 315 and can be attached thereto for example by gluing, to form the flat structure shown in Figure 25.

[0055] Conveniently, blanks 311 can be stored in this flat arrangement and transported to packaging machinery ready to be loaded into suitable hoppers such as hopper H shown schematically in Figure 30.

[0056] To load a carton the structure shown in Figure 25 is first expanded into the sleeve like structure as shown in Figure 26. This is also shown in the upstream part of the packaging process shown in Figure 30, wherein it is apparent that the carton is moved downstream along the flow direction indicated by arrow F. In this schematic drawing it can be seen that at stage A, the infeed rows of articles are separated into the desired formation of two rows on each of the open ends of the carton comprising an innermost row of four articles and an adjacent outermost row of three articles. The outer row is displaced

slightly with respect to the inner row so that the rows of articles are nested thereby to form a relatively tightly packed configuration.

[0057] That is, an article in the outer row abuts two articles in the inner row. This is not true of the abutment of the two inner rows after they have been loaded into the carton during the phase indicated by section B of Figure 30. The adjacent innermost rows of four articles abut one another so that only a single article is abutted in the adjacent innermost row. However, for different sizes or shapes of cartons it would of course be possible to provide a different structure of abutment of the articles within the carton.

[0058] After loading a carton 320, the gussets 338 and 340 are tucked inwardly in zone C of the flow path shown in Figure 30. As shown in bubble G of Figure 30, main gusset panel 358c is tucked inwardly to a position beneath top panel 320. Also, as shown in bubble H of Figure 30, the gussets 340 are tucked upwardly. This tucking action of the gussets causes a bending of the side panels towards the partially closed structure shown in Figure 27. The endmost parts of the side panels 350a and 350b can then be drawn further round to the ends of the carton as shown in zone D of Figure 30. This causes further curvature of side panels 314 and 316 which thereby contour the sides of the adjacent articles and reflect the shape of three sides of the octagonal base panel 312 and top panel 320. Additionally, the upper portions of the side panels 314 and 316 bevel in, or are inclined, thereby to contour the shoulders of the bottles retained within a carton.

[0059] The upper and lower end panels 322, 324, 328 and 326 can then be folded about the associated fold line to the top or lower panel as shown in Figure 28. The associated upper and lower end panels such as panels 328 and 322 can then be attached to one another for example by gluing. Alternatively, cooperating locking means such as locking tabs and apertures might be provided. Also, the end panels can be attached to the end panels 346a, 346b, 350a and 350b. For example, if an adhesive such as glue is used then the finished carton shown in Figure 29 can be pressed in zone E of Figure 30 to ensure the panels remain closed.

45 **Statements of Invention**

[0060] A blank (11) for forming a carton for packaging a plurality of articles comprising a first panel (18) having a comer; a second panel (14) neighbouring said first panel, adjacent edges of said first and second panels being disposed to converge on said comer; and a gusset (38d) extending between said adjacent edges and foldably connected to said first and second panels along said adjacent edges, said gusset comprising a pair of gusset panels (58, 60) interconnected along a fold line, one (60) of said gusset panels extending between a free outer edge of said gusset and an inner edge (62) thereof which is itself spaced from said corner to facilitate folding of

said gusset, said fold line extending from said inner edge (62) to said free outer edge of said gusset (38d) characterised in that the other gusset panel (58) includes a portion (59) disposed in the region between said inner edge (62) and said corner, wherein the tab (59) is shaped for ease of folding of said gusset when said blank is erected to form a carton.

[0061] The blank as claimed in claim 1 wherein said tab (59) is shaped to close said region upon formation of said carton.

[0062] The blank according to claim 1 or claim 2 wherein said tab (59) is formed from said one gusset panel (60) and defines said region.

[0063] The blank according to any one of the preceding claims, wherein said one gusset panel (60) is foldably connected to said first panel (18), and said other gusset panel (58) is foldably connected to said second panel (14).

[0064] The blank according to claim 4 wherein said other gussets panel (60) is positioned between said first panel (18) and a top of one of said articles upon formation of said carton.

[0065] The blank according to any one of the preceding claims wherein said first panel (18) is non-rectangularly shaped

[0066] A carton blank according to claim 6 wherein said second panel (14) comprises an end panel portion (42b) and a medial panel portion (46b) foldably connected together by a fold region (44b) so that upon formation of said carton, said second panel is folded to a formed position where said end and medial panel portions are put into at least two different planes to conform with a shape of said first panel.

[0067] A blank according to claim 7, wherein said first panel (118, 218, 330) has an end panel (128, 228, 328) foldably connected thereto, and one of said gusset panels comprises means (159, 359) for operably abutting said end panel to help retain said second panel in said formed position.

[0068] The blank according to claim 8, wherein said abutting means (159, 359) is provided by said other gusset panel (158b, 358a).

[0069] The blank according to claim 9, wherein said abutting means (159, 359) comprises a second tab protruding from said other gusset panels away from said corner.

[0070] The blank according to claim 10, said abutting means (159, 359) comprises an edge (357a) of said second tab.

[0071] A blank according to any one of the preceding claims wherein said fold regions (44b) each comprises a plurality of crease lines.

[0072] The blank according to claim 12, wherein said fold regions are curvable portions which provided rounded corners in said carton.

[0073] The blank according to any one of preceding claims, wherein said first panel (18) has an end edge (25d) and first and second adjoining side edges, said first

side edge is disposed between said end edge and said second side edge and comprises said adjacent edge (64b) of said first panel, said corner is defined between said first and second side edges, and an end panel is foldably jointed to said end edge.

[0074] The blank according to claim 14, wherein said second panel (14) is foldably connected to said first panel along said second side edge.

[0075] The blank according to claim 15, wherein said second side edge extends from said corner away from said gusset (38) and is aligned with said adjacent edge of said second panel (14).

15 Claims

1. A blank for forming a carton for packaging a plurality of articles, which blank comprising a first panel (118, 218, 330) having a corner; a second panel (114, 214, 316) neighbouring said first panel, adjacent edges of said first and second panels being disposed to converge on said corner; and a gusset (138, 338) extending between said adjacent edges and foldably connected to said first and second panels along said adjacent edges, said gusset comprising a pair of gusset panels (158, 160; 358, 360) interconnected along a fold line, **characterised in that** said first panel has an end panel (128, 228, 328) foldably connected thereto, and one (158, 358) of said gusset panels comprises means (159, 359) for operably abutting said end panel to help retain said second panel in a formed position upon formation of said carton.
2. The blank according to claim 1, wherein said second panel (114, 214, 316) comprises an end panel portion (142, 242, 350) and a medial panel portion (146, 246, 385) foldably connected together by a fold region (143) so that upon formation of said carton, said second panel is folded to said formed position where said end and medial panel portions are put into at least two different planes to conform with a shape of said first panel.
3. The blank according to claim 1 or 2, wherein said first panel (118, 218, 330) is non-rectangularly shaped
4. The blank according to any one of claims 1 to 3, wherein said abutting means (159, 359) is provided by said one gusset panel (158, 358).
5. The blank according to any one of claims 1 to 4, wherein said abutting means (159, 359) comprises a tab protruding from said one gusset panel away from said corner.
6. The blank according to claim 5, wherein said abutting means (159, 359) comprises an edge (357a) of said

tab.

7. A carton for packaging a plurality of articles, which carton comprises a first panel (118, 218, 330) having a comer; a second panel (114, 214, 316) neighbouring said first panel, adjacent edges of said first and second panels being disposed to converge on said comer; and a gusset (138, 338) extending between said adjacent edges and foldably connected to said first and second panels along said adjacent edges, said gusset comprising a pair of gusset panels (158, 160; 358, 360) interconnected along a fold line, **characterised in that** said first panel has an end panel (128, 228, 328) foldably connected thereto, and one (158, 358) of said gusset panels comprises means (159, 359) for operably abutting said end panel to help retain said second panel in a formed position upon formation of said carton. 5 10 15
8. The carton according to claim 7, wherein said second panel (114, 214, 316) comprises an end panel portion (142, 242, 350) and a medial panel portion (146, 246, 385) foldably connected together by a fold region (143) so that upon formation of said carton, said second panel is folded to said formed position where said end and medial panel portions are put into at least two different planes to conform with a shape of said first panel. 20 25
9. The carton according to claim 7 or 8, wherein said first panel (118, 218, 330) is non-rectangularly shaped 30
10. The carton according to any one of claims 7 to 9, wherein said abutting means (159, 359) is provided by said one gusset panel (158, 358). 35
11. The carton according to any one of claims 7 to 10, wherein said abutting means (159, 359) comprises a tab protruding from said one_gusset panel away from said corner. 40
12. The carton according to claim 11, wherein said abutting means (159, 359) comprises an edge (357a) of said tab. 45

50

55

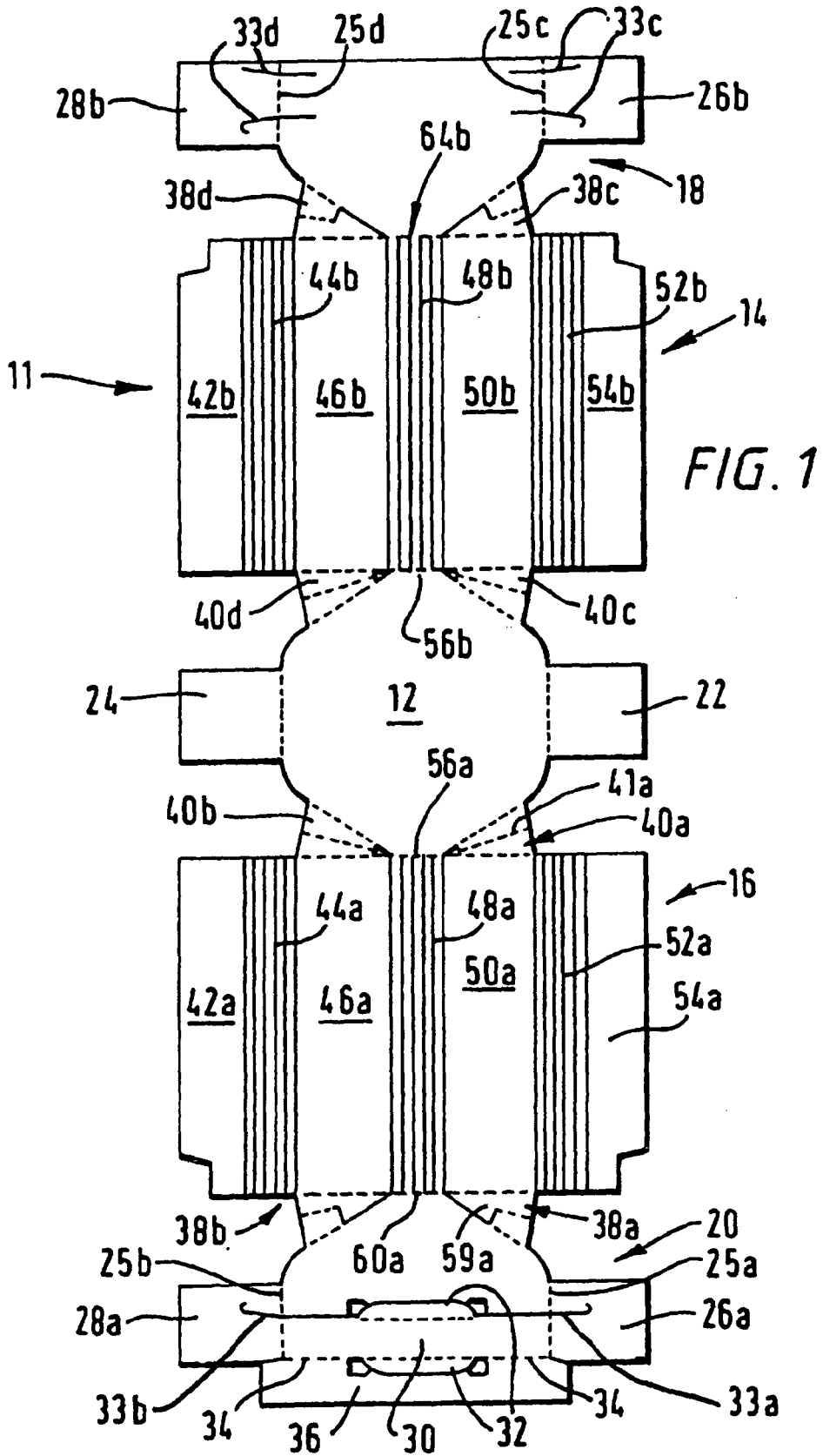

FIG. 2

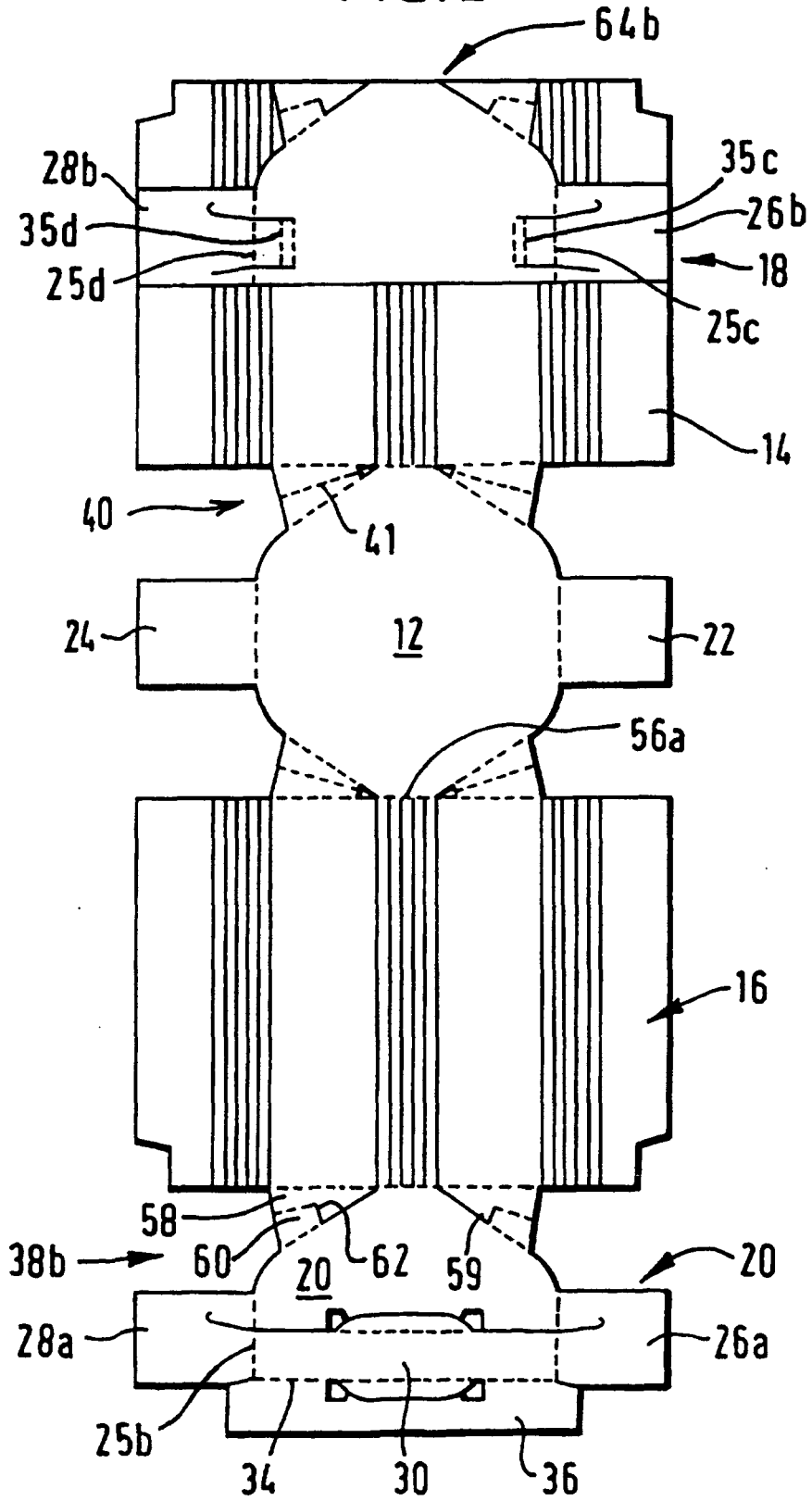

FIG. 3

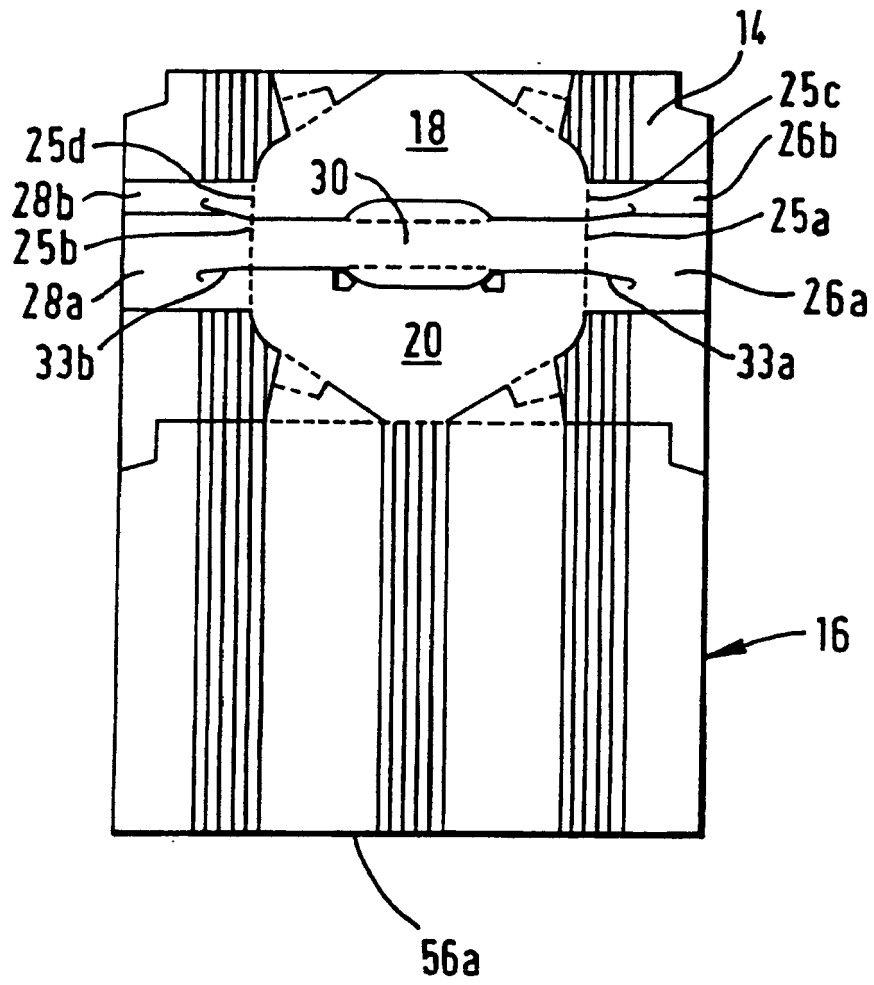

FIG. 4

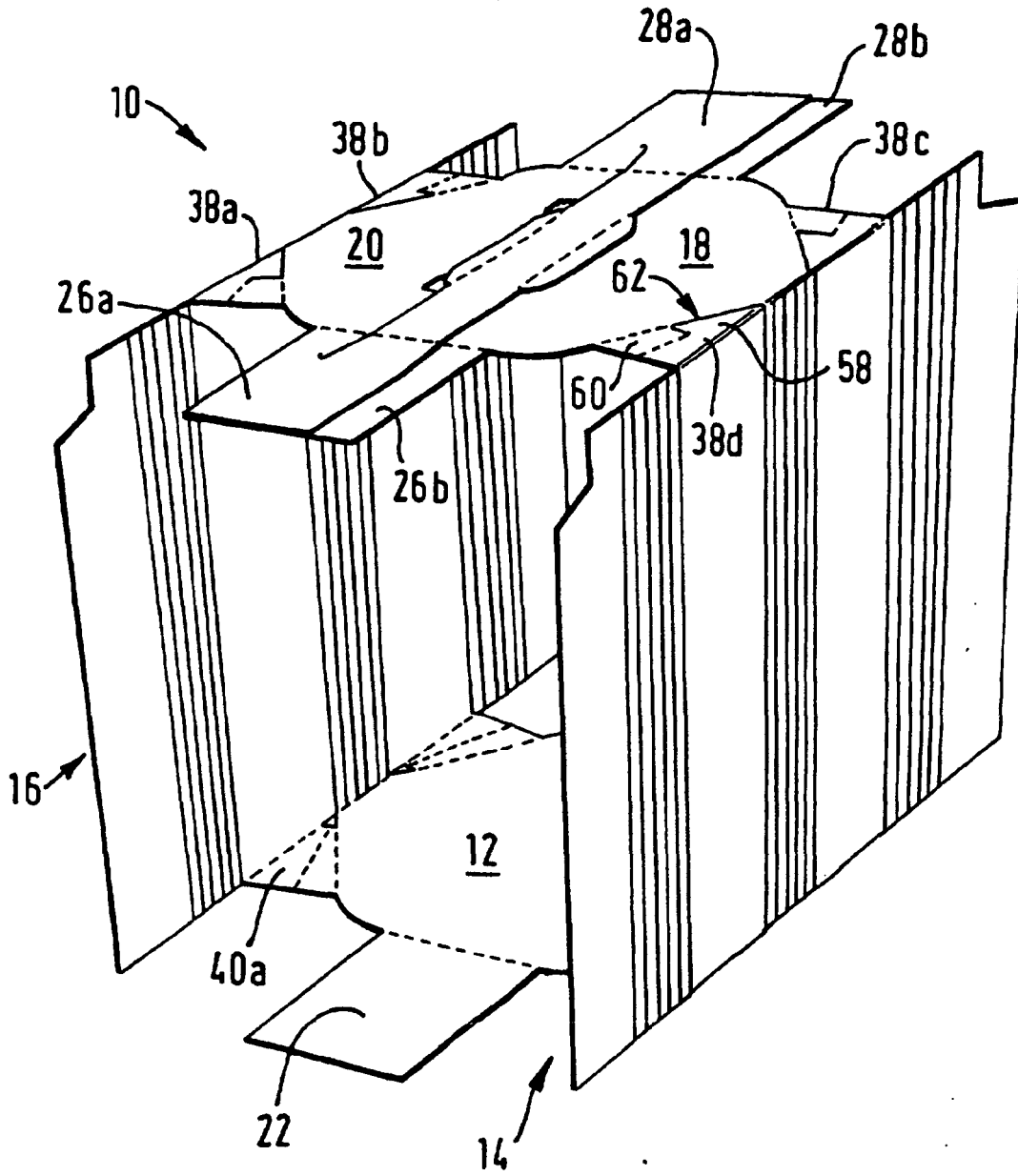
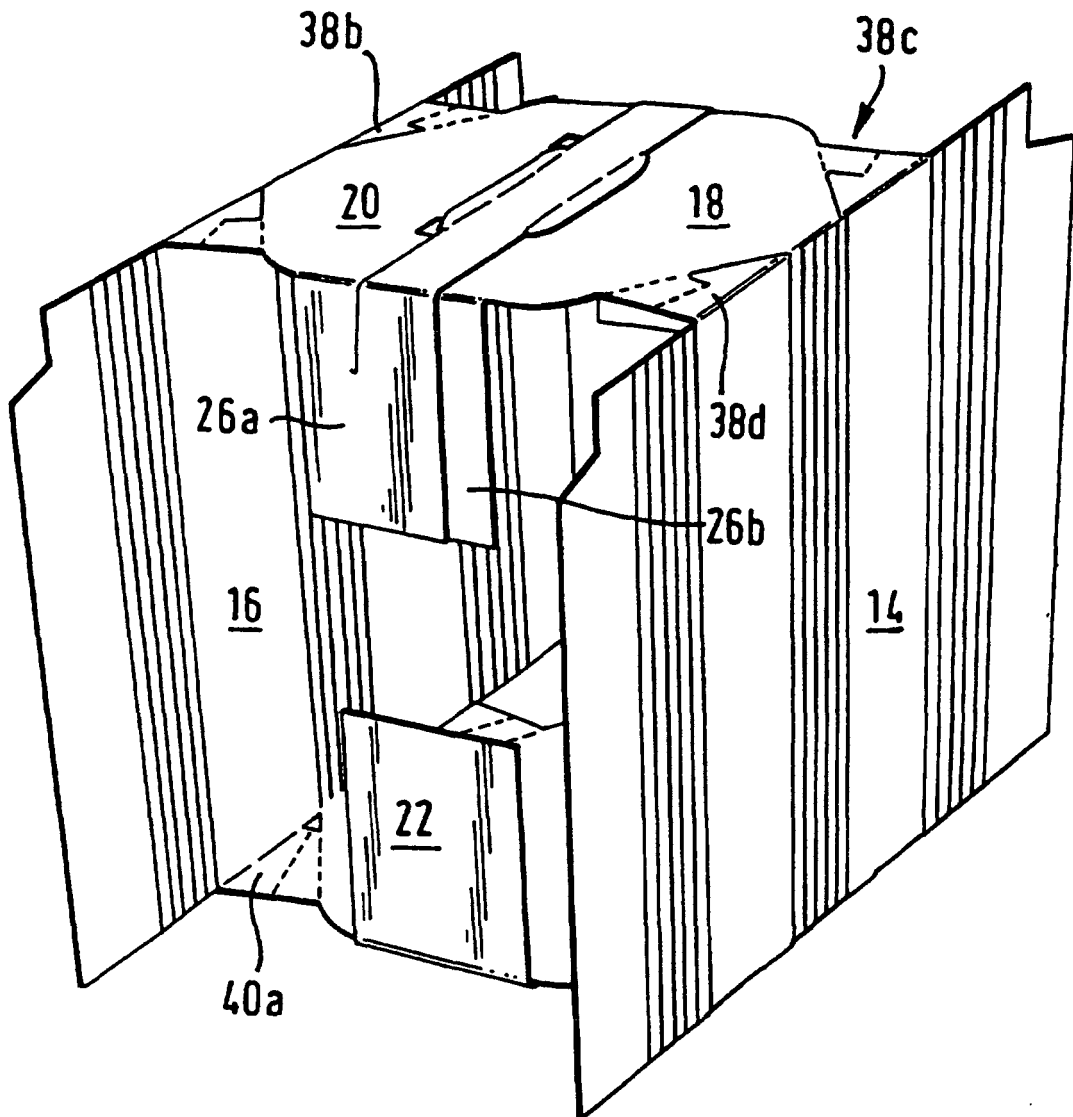

FIG. 5



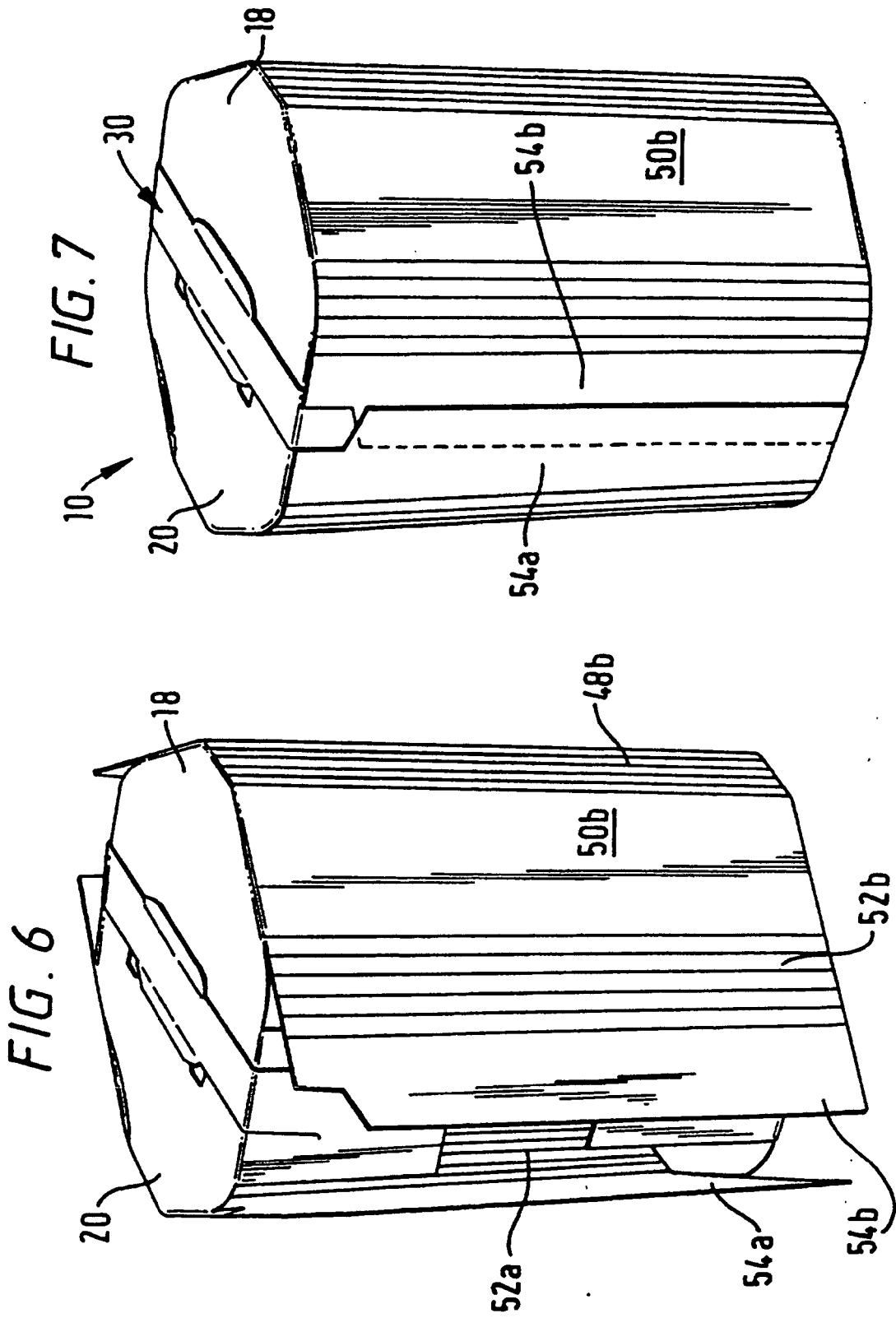

FIG. 8

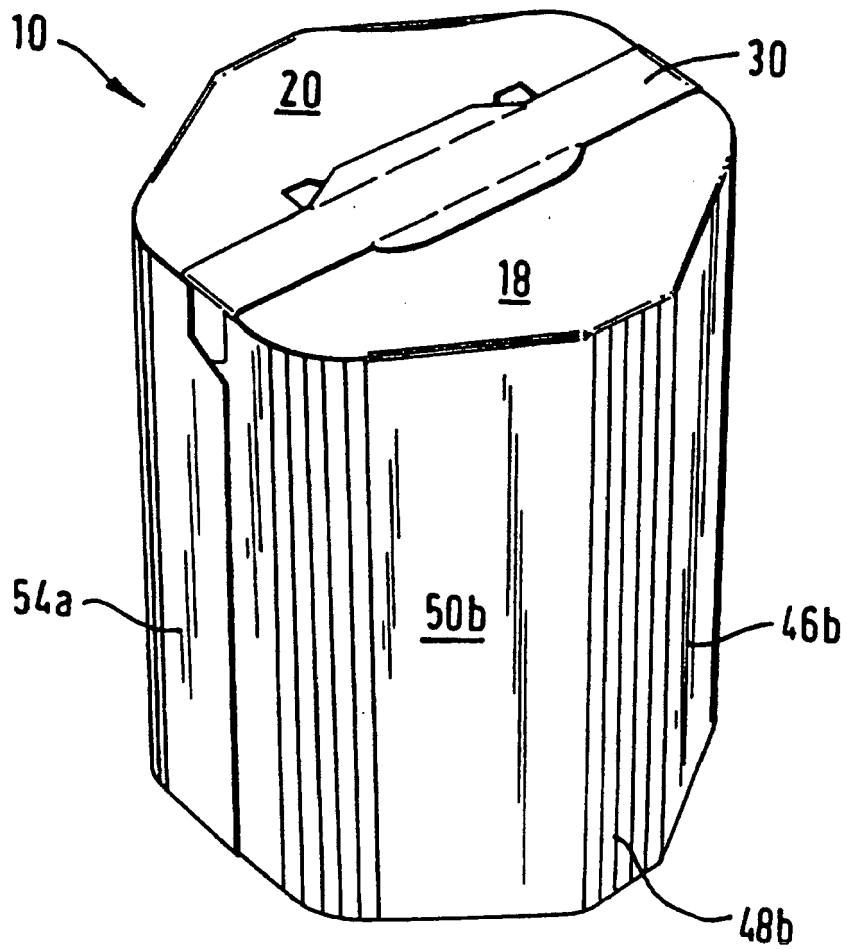

FIG. 11

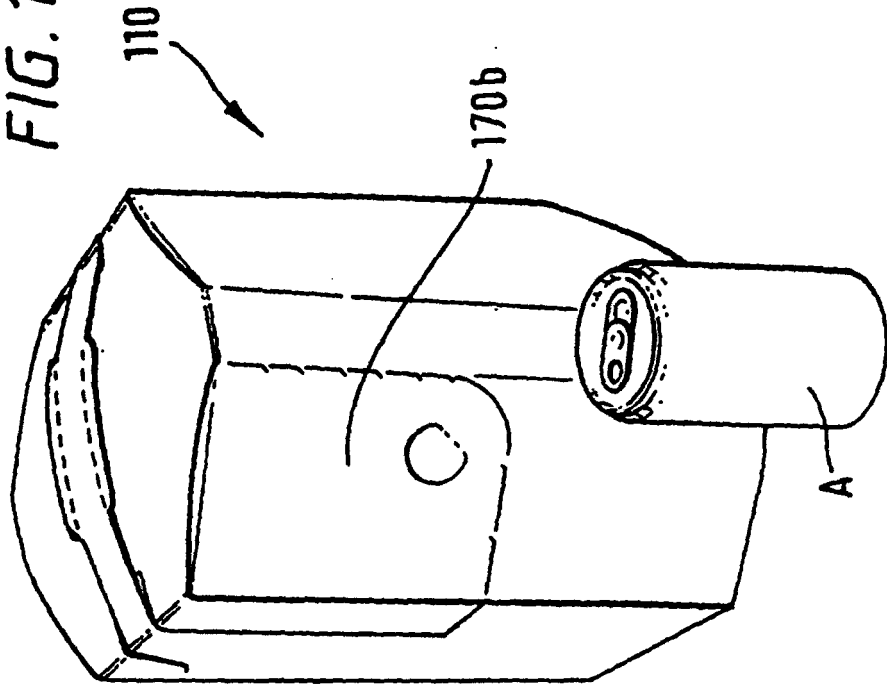

FIG. 10

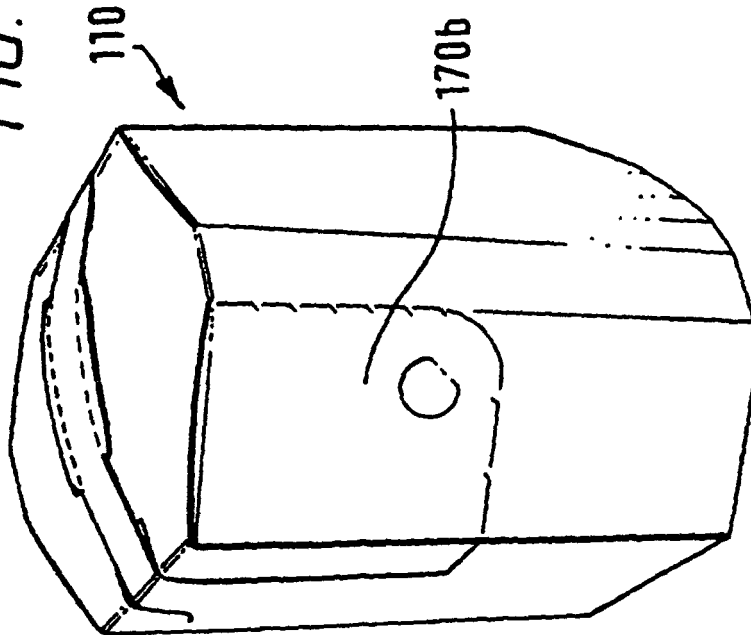

FIG. 12

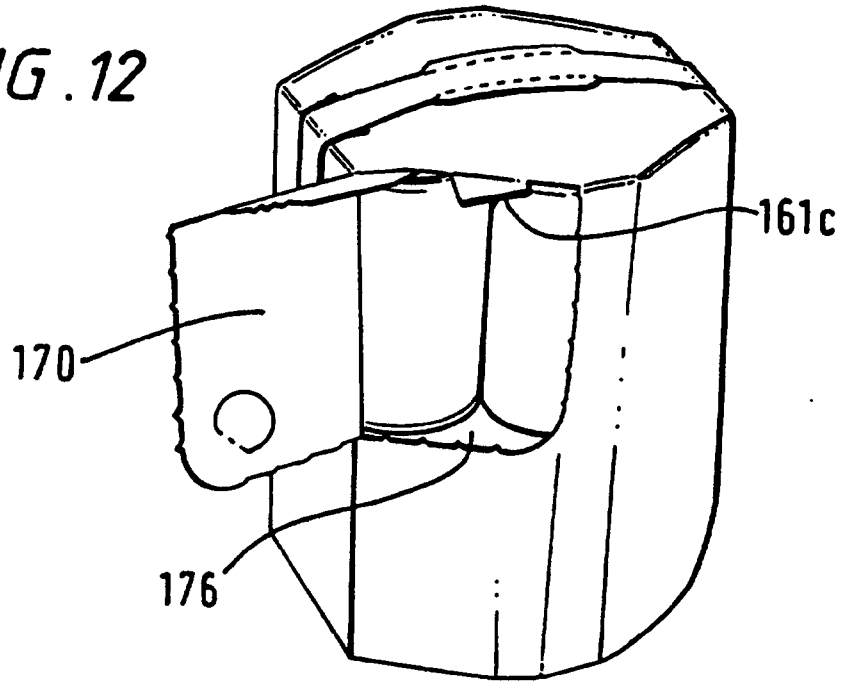
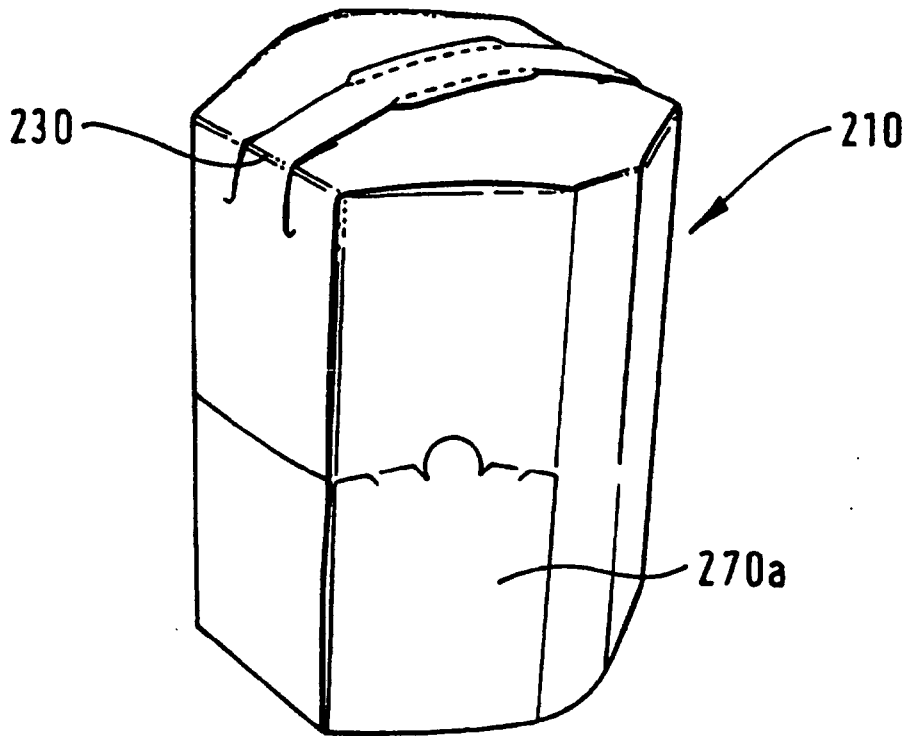

FIG. 16



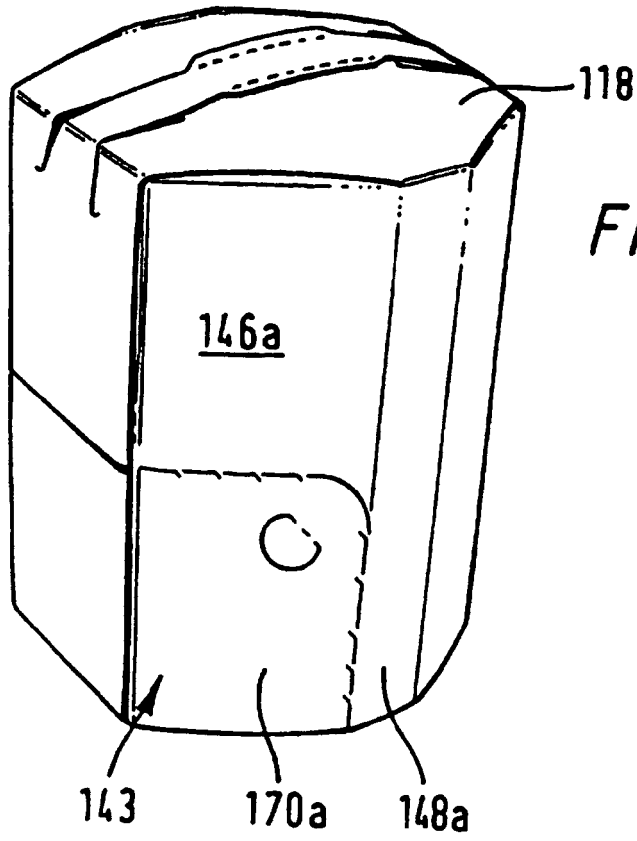

FIG. 13

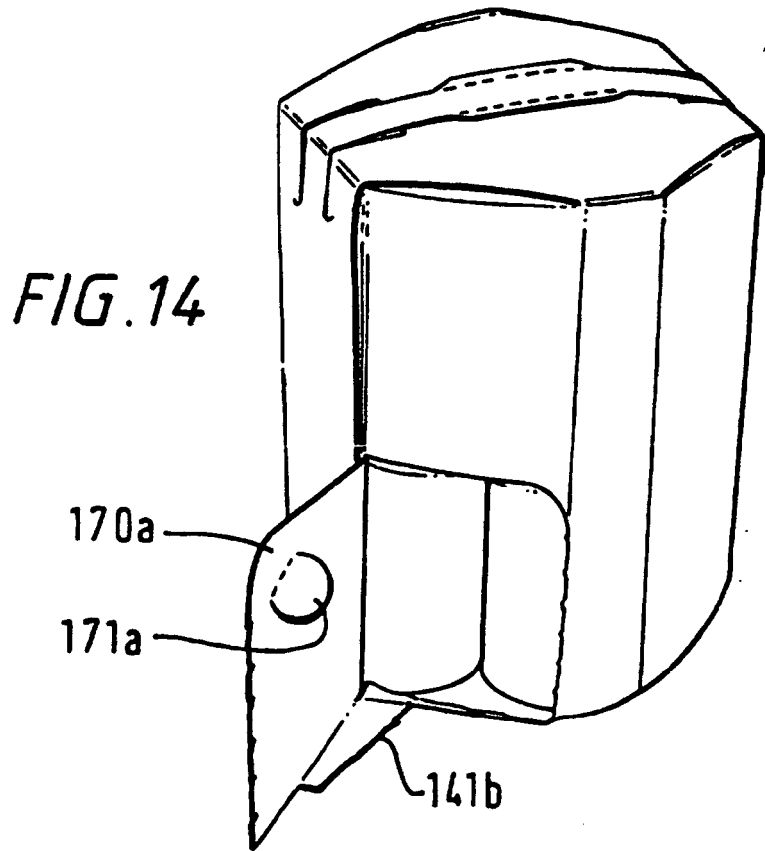

FIG. 15

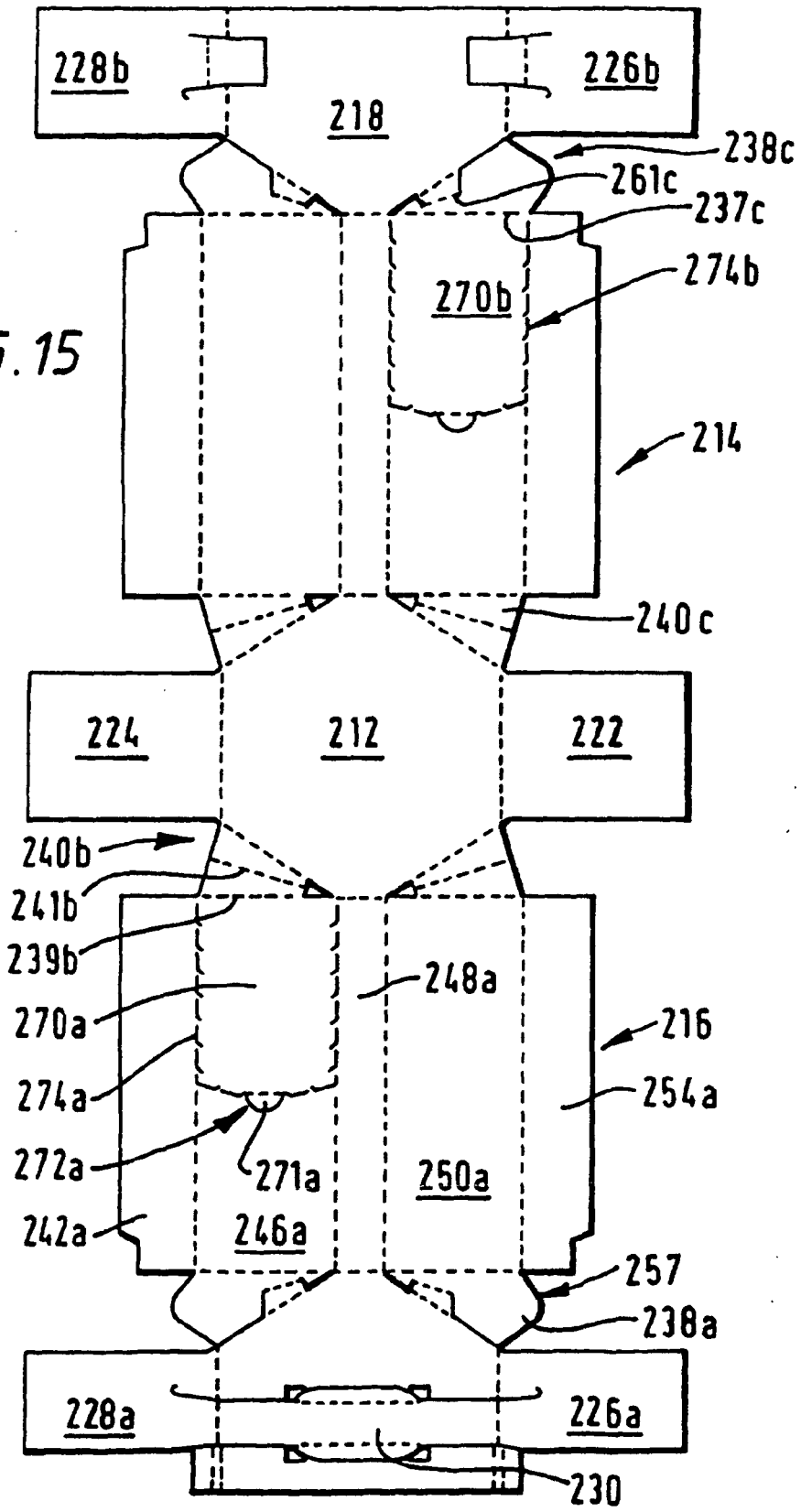
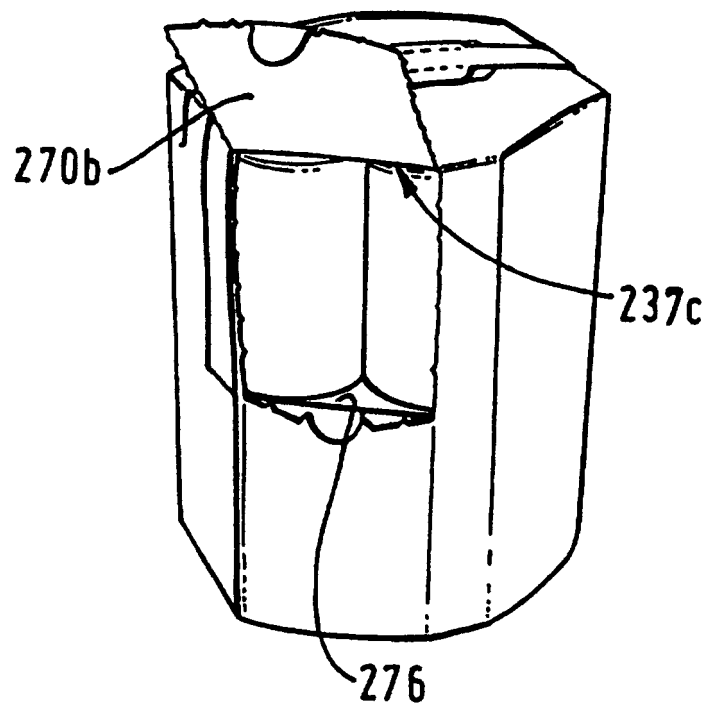

FIG. 17



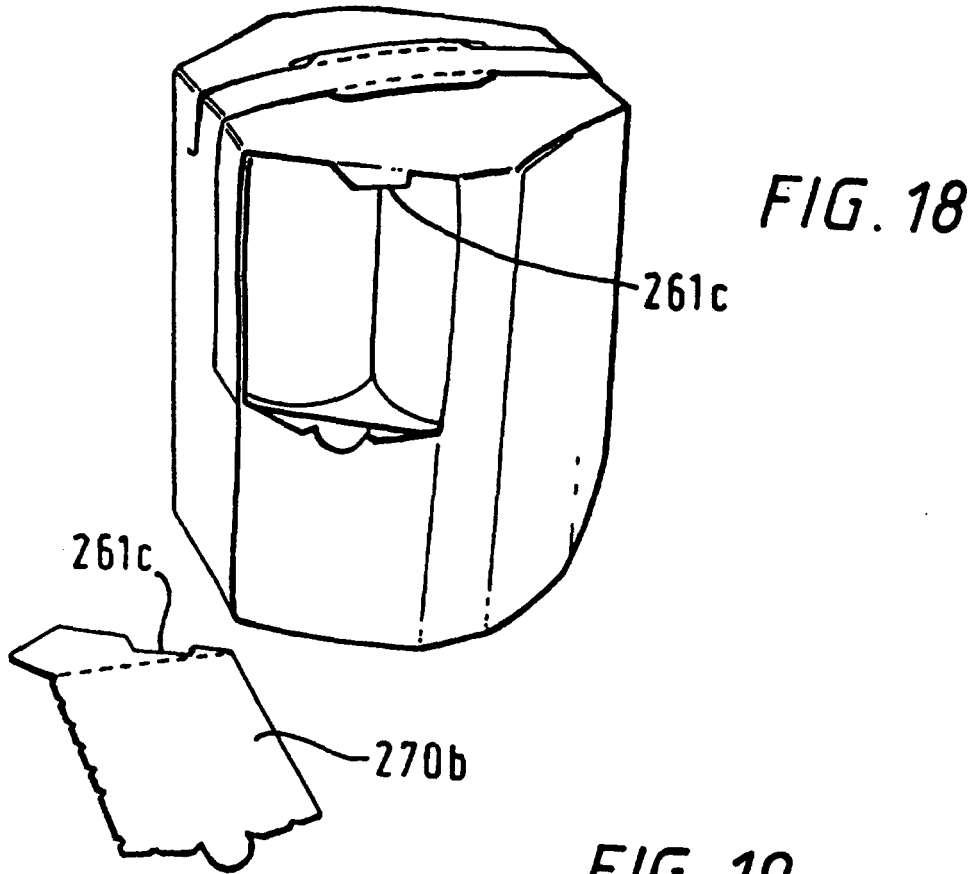
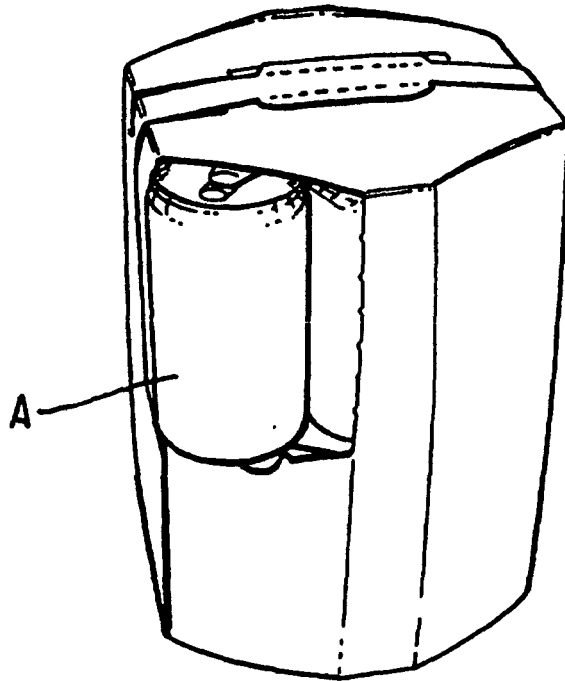

FIG. 19



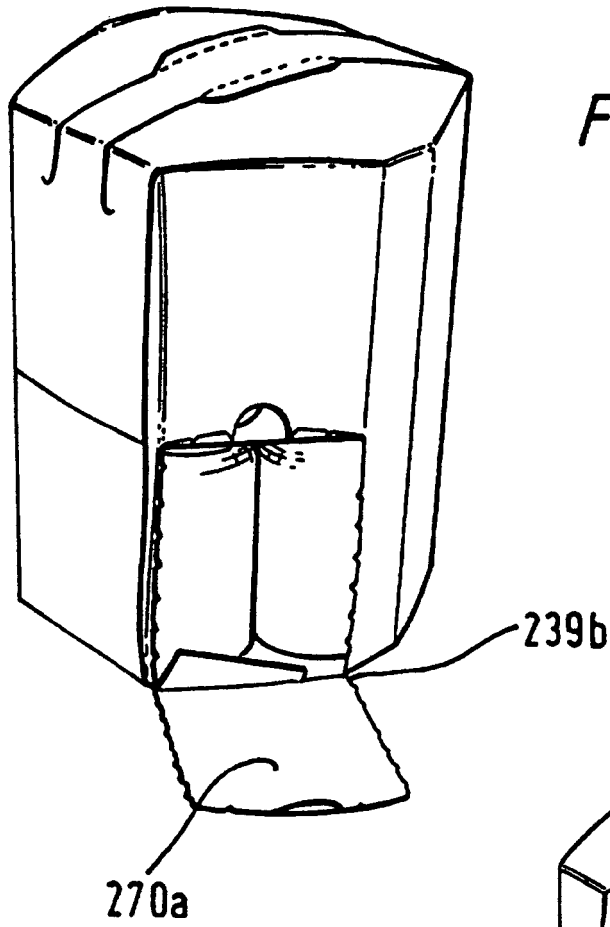

FIG. 21

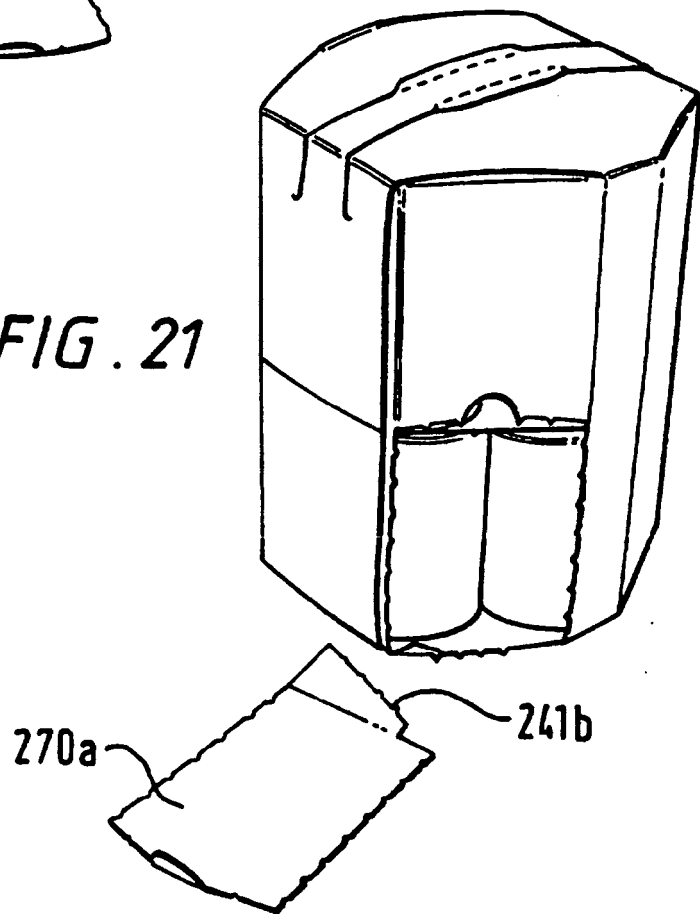

FIG. 22

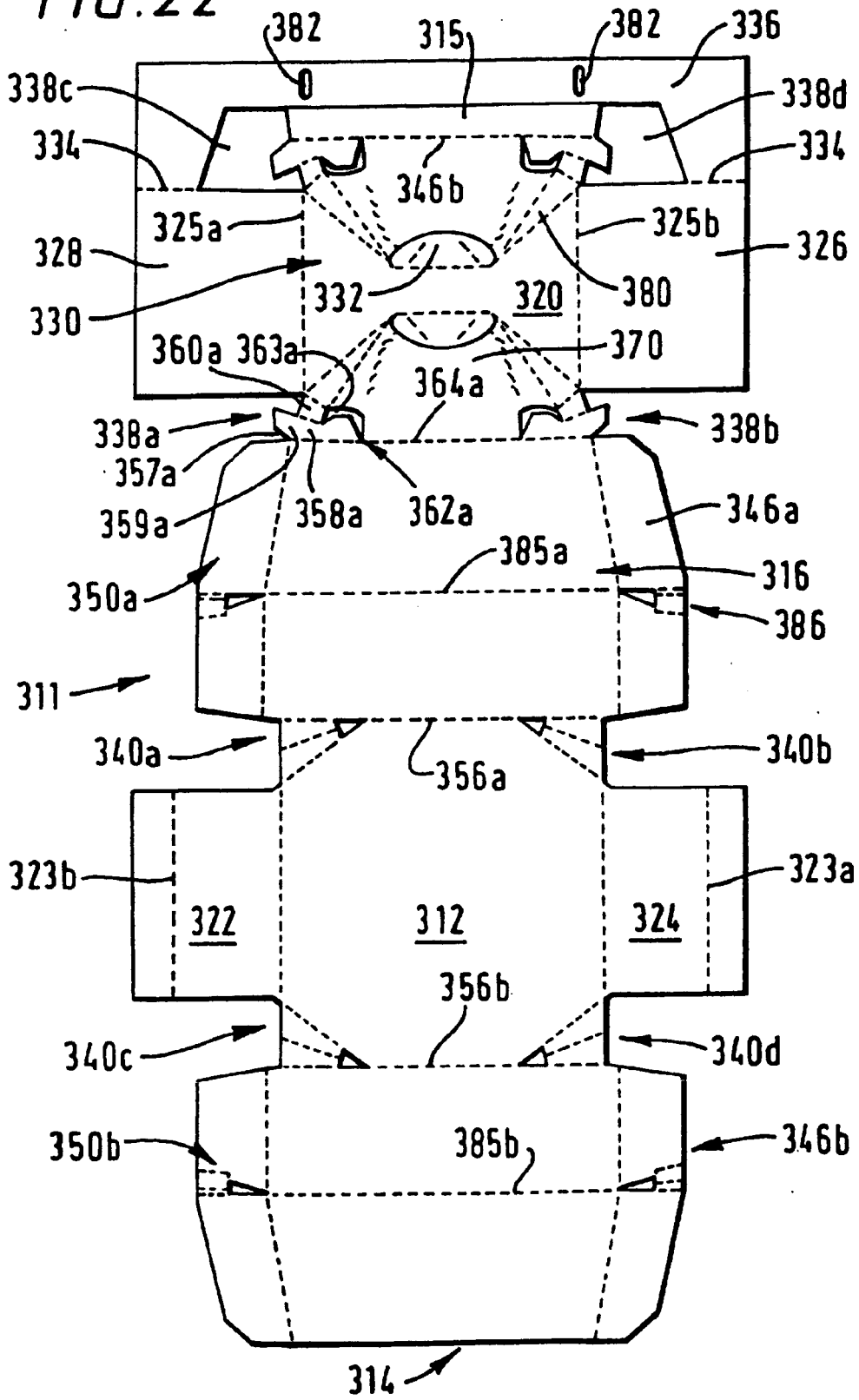

FIG. 23

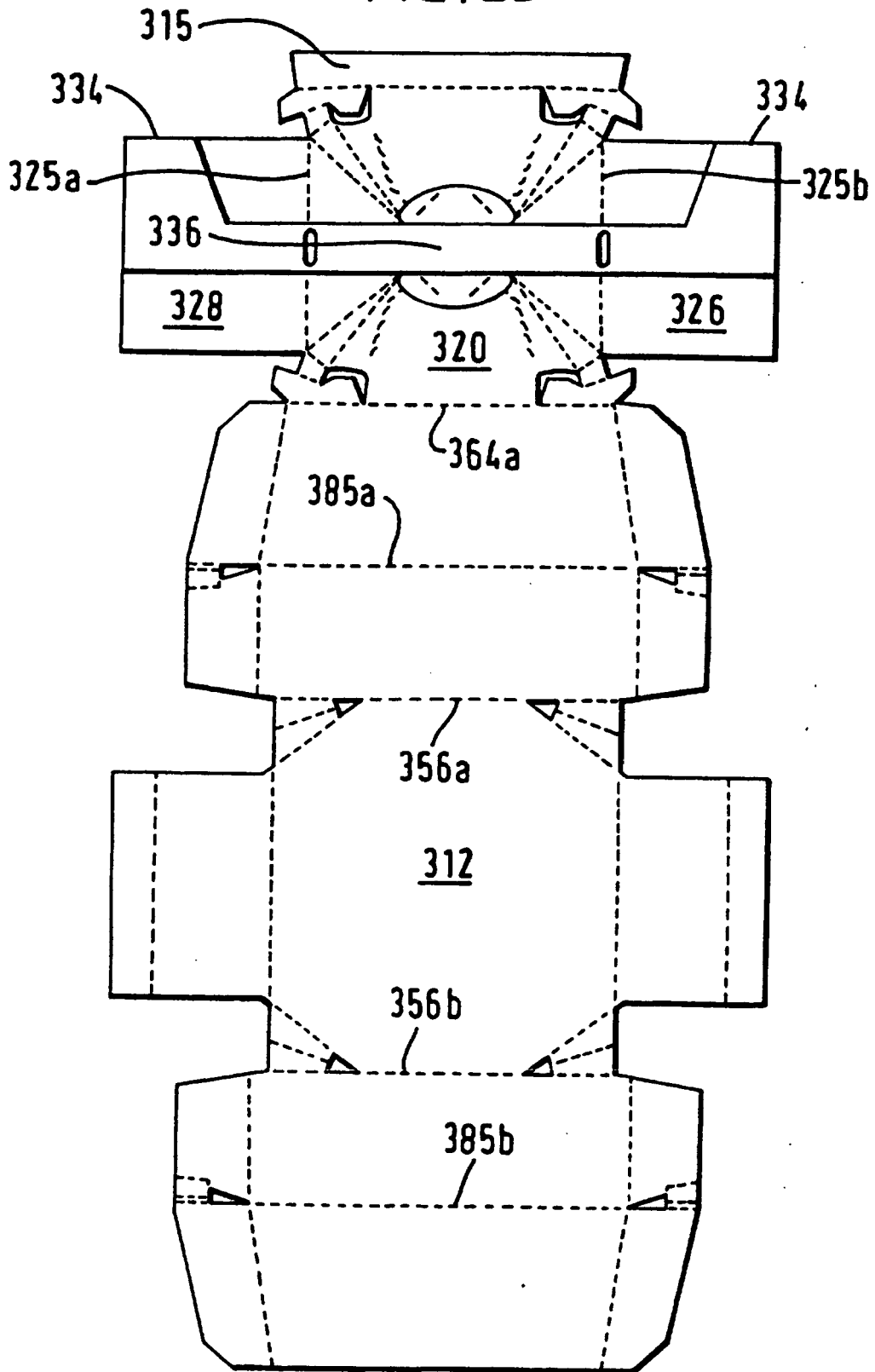

FIG. 24

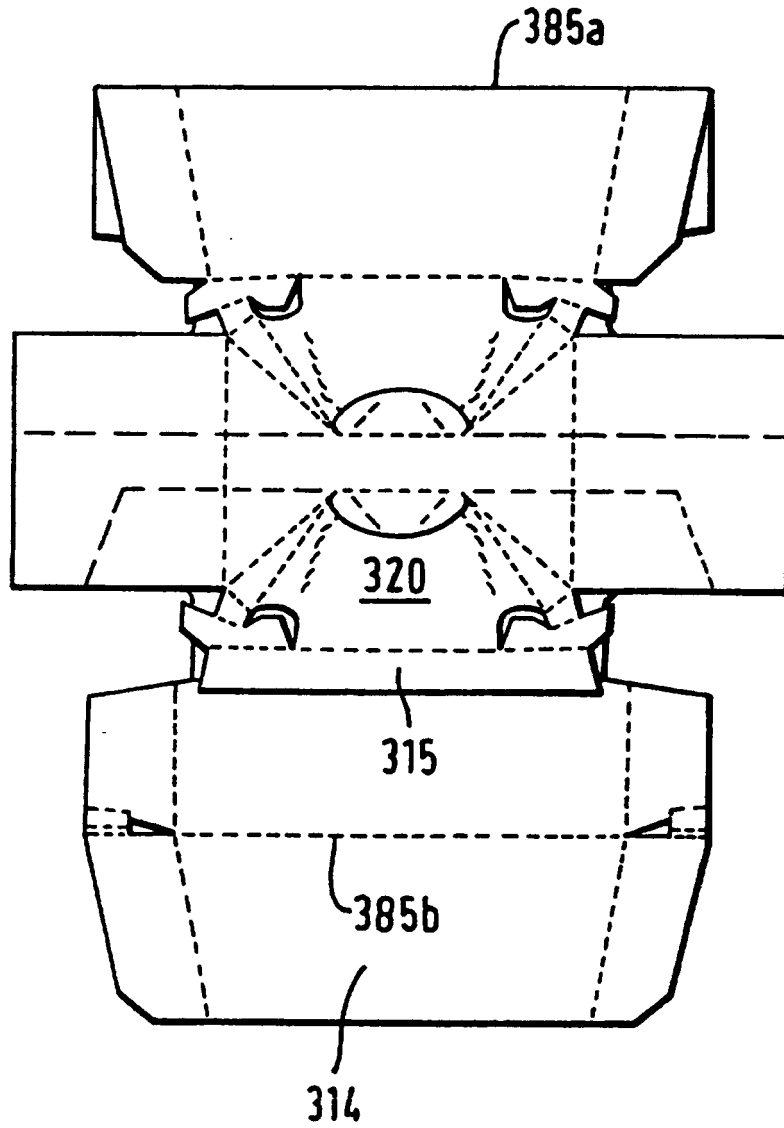

FIG. 25

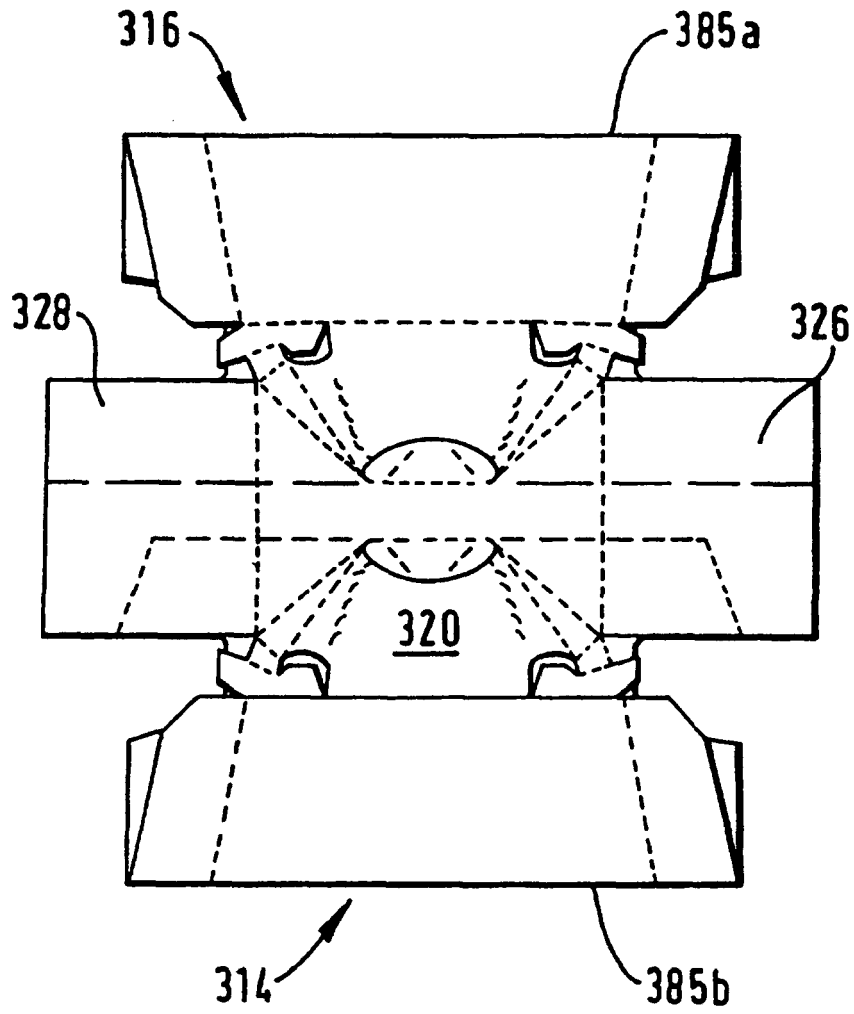

FIG. 26

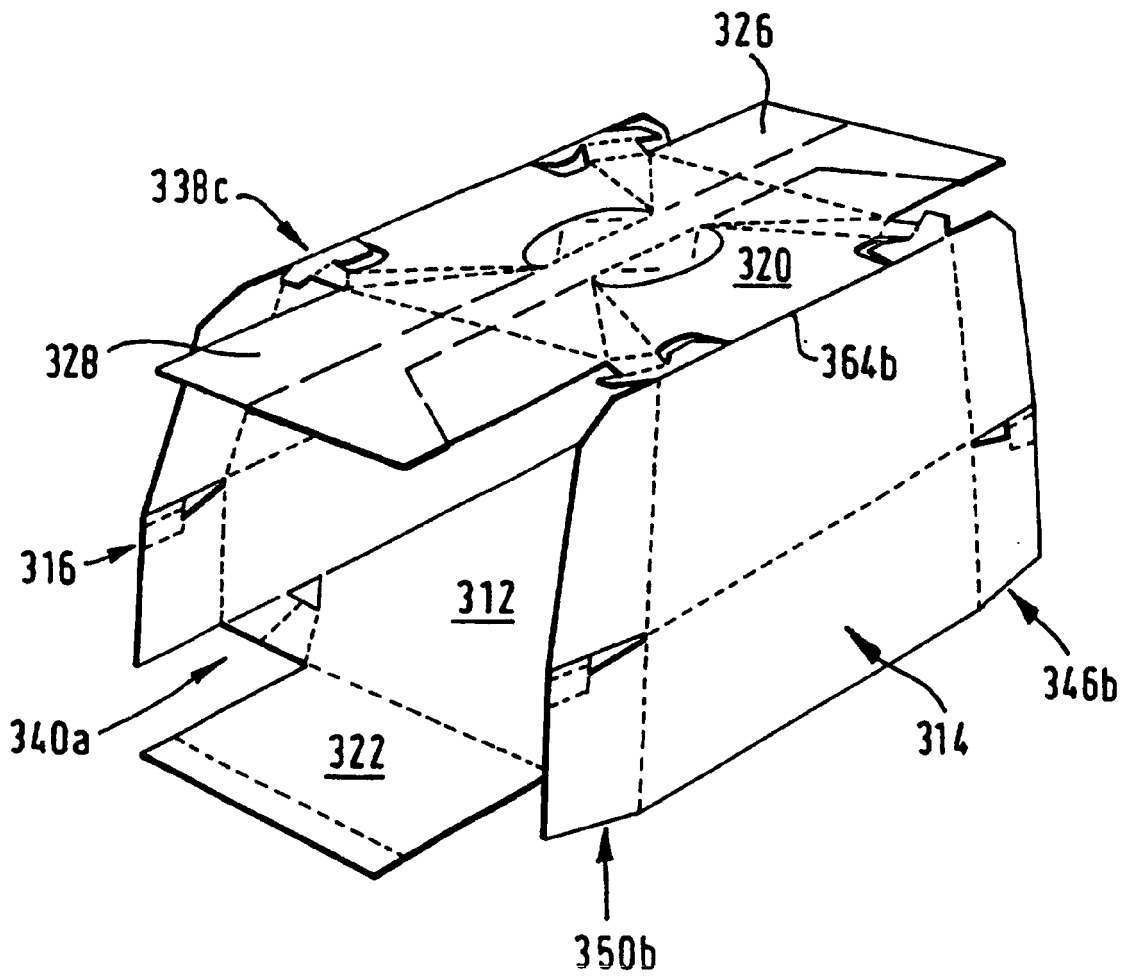

FIG. 27

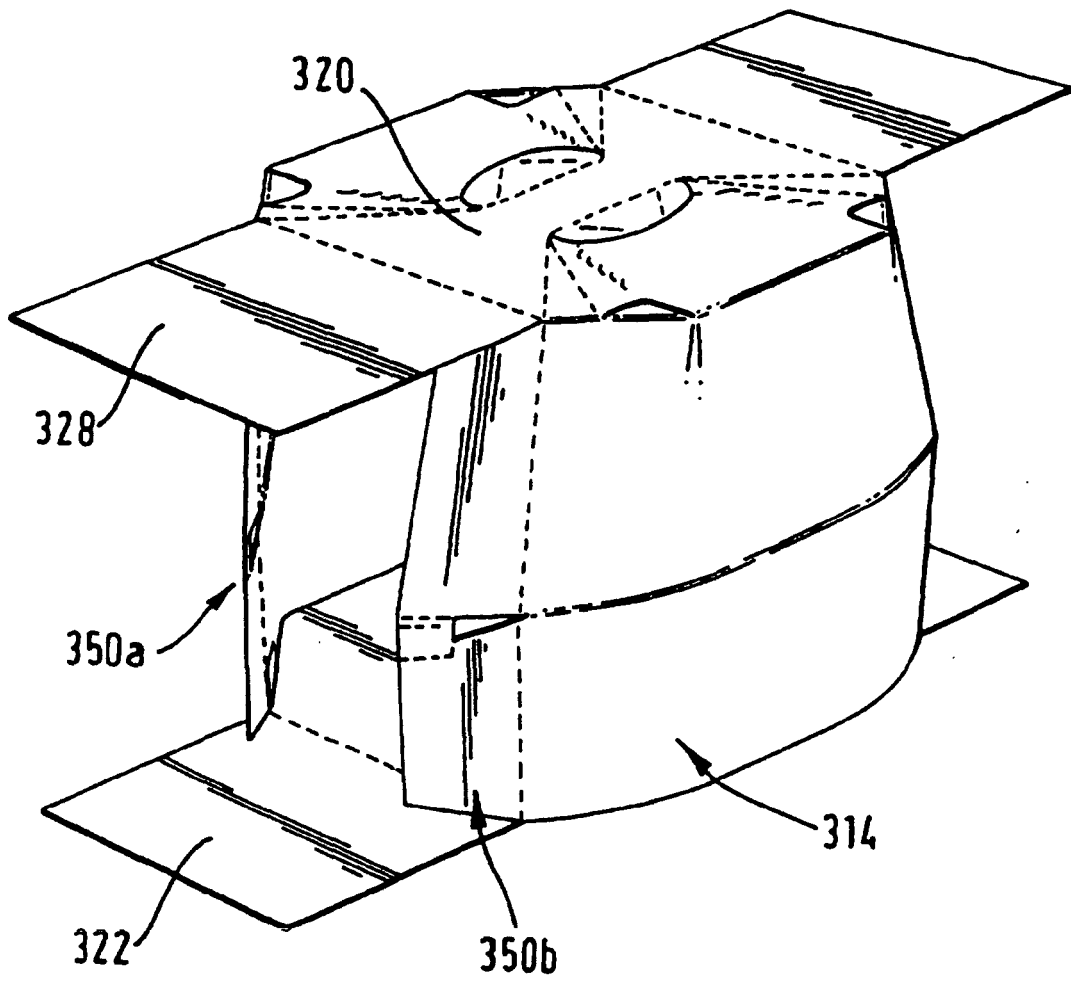

FIG. 28

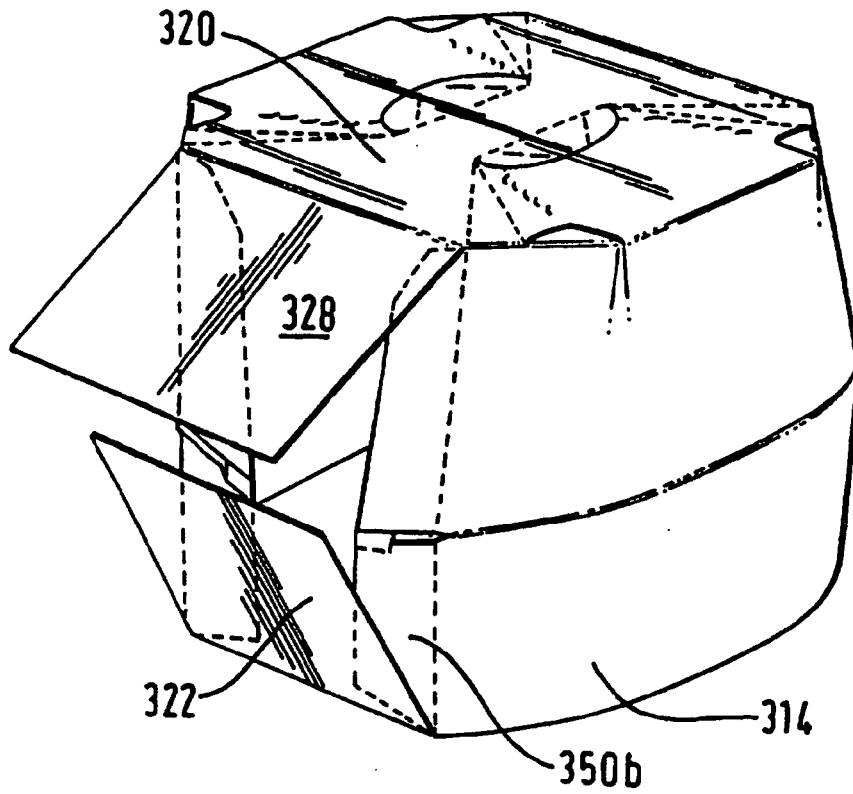

FIG. 29

