

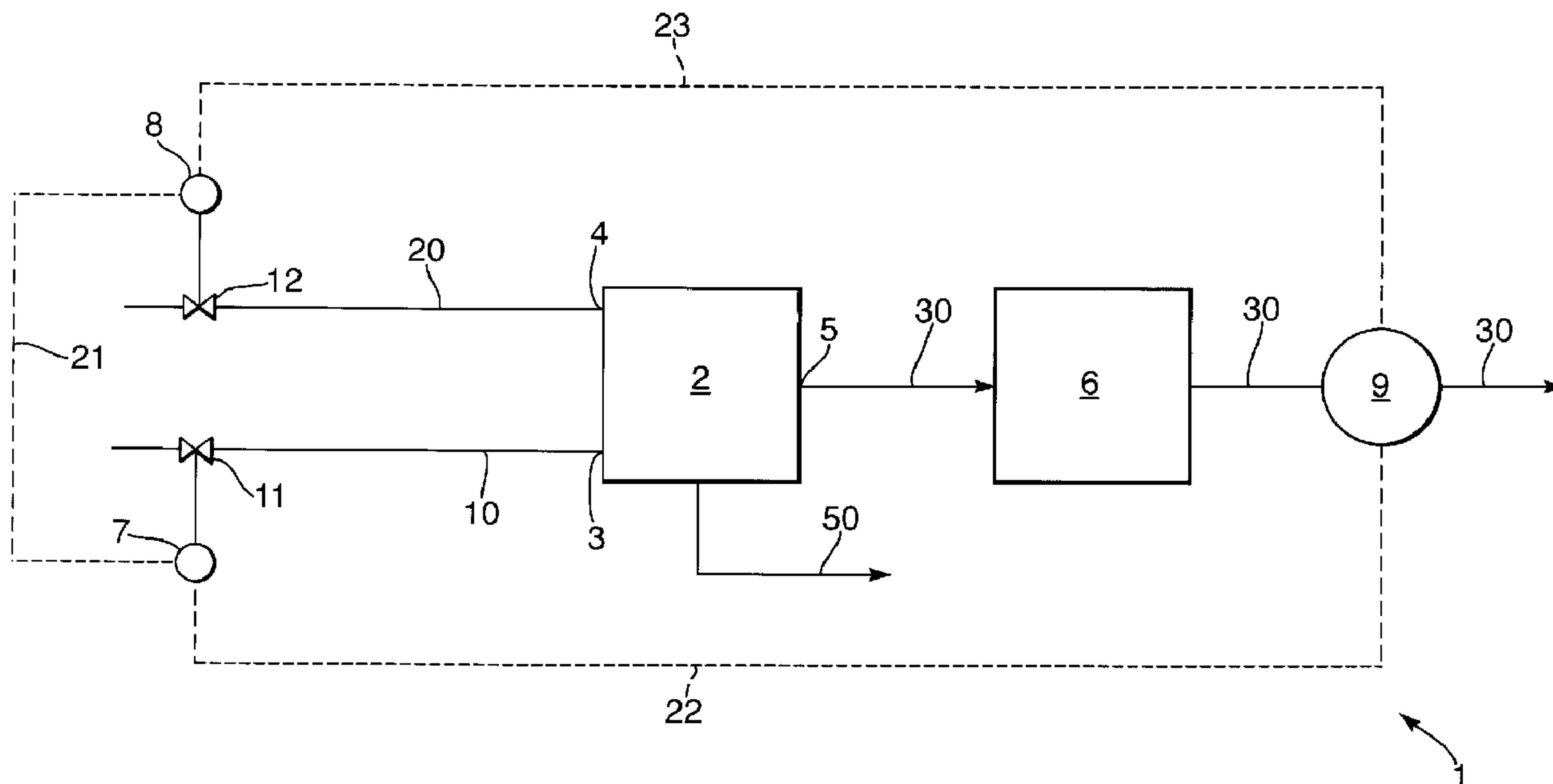

(86) Date de dépôt PCT/PCT Filing Date: 2006/12/12  
 (87) Date publication PCT/PCT Publication Date: 2007/06/21  
 (45) Date de délivrance/Issue Date: 2014/09/30  
 (85) Entrée phase nationale/National Entry: 2008/06/10  
 (86) N° demande PCT/PCT Application No.: EP 2006/069573  
 (87) N° publication PCT/PCT Publication No.: 2007/068684  
 (30) Priorité/Priority: 2005/12/14 (EP05112111.9)

(51) Cl.Int./Int.Cl. *C10J 3/78* (2006.01),  
*C10J 3/00* (2006.01), *G05D 11/13* (2006.01)  
 (72) Inventeurs/Inventors:  
SCHEERMAN, JACOBUS HENDRIKUS, NL;  
PLOEG, JOHANNES EVERDINUS GERRIT, NL  
 (73) Propriétaire/Owner:  
SHELL INTERNATIONALE RESEARCH  
MAATSCHAPPIJ B.V., NL  
 (74) Agent: NORTON ROSE FULBRIGHT CANADA  
LLP/S.E.N.C.R.L., S.R.L.

(54) Titre : PROCÉDE DE FABRICATION D'UN GAZ DE SYNTHÈSE  
 (54) Title: METHOD OF PRODUCING SYNTHESIS GAS



(57) Abrégé/Abstract:

The present invention relates to a method of producing synthesis gas by partial oxidation of a carbonaceous stream, wherein the partial oxidation is controlled using an oxygen to carbon ratio (O/C ratio), the method comprising at least the steps of: (a) feeding a carbonaceous stream and an oxygen containing stream into a gasification reactor at a selected O/C ratio; (b) at least partially oxidising the carbonaceous stream in the gasification reactor, thereby obtaining a gaseous product stream at least containing synthesis gas, CO<sub>2</sub> and CH<sub>4</sub>; (c) determining the content of CO<sub>2</sub>, in the product stream obtained in step (b); (d) comparing the content determined in step (c) with a pre-determined content thereby possibly obtaining a difference value between the content determined in step (c) and the pre-determined content; (e) adjusting the O/C ratio in step (a) based on the difference value obtained in step (d).



## (12) INTERNATIONAL APPLICATION PUBLISHED UNDER THE PATENT COOPERATION TREATY (PCT)

(19) World Intellectual Property Organization  
International Bureau(43) International Publication Date  
21 June 2007 (21.06.2007)

PCT

(10) International Publication Number  
**WO 2007/068684 A3**

## (51) International Patent Classification:

*C10J 3/78* (2006.01)      *G05D 11/13* (2006.01)  
*C10J 3/00* (2006.01)

## (21) International Application Number:

PCT/EP2006/069573

## (22) International Filing Date:

12 December 2006 (12.12.2006)

## (25) Filing Language:

English

## (26) Publication Language:

English

## (30) Priority Data:

05112111.9      14 December 2005 (14.12.2005)      EP

(71) Applicant (for all designated States except US): **SHELL INTERNATIONALE RESEARCH MAATSCHAPPIJ B.V.** [NL/NL]; Carel van Bylandtlaan 30, NL-2596 HR The Hague (NL).

## (72) Inventors; and

(75) Inventors/Applicants (for US only): **SCHEERMAN, Jacobus Hendrikus** [NL/NL]; Badhuisweg 3, NL-1031 CM Amsterdam (NL). **PLOEG, Johannes Everdinus Gerrit** [NL/NL]; H.J. Schimmellaan 1, NL-1405 HR Bussum (NL).

(74) Agent: **Shell International B.V.**; Intellectual Property services, PO Box 384, NL-2501 CJ The Hague (NL).

(81) Designated States (unless otherwise indicated, for every kind of national protection available): AE, AG, AL, AM, AT, AU, AZ, BA, BB, BG, BR, BW, BY, BZ, CA, CH, CN, CO, CR, CU, CZ, DE, DK, DM, DZ, EC, EE, EG, ES, FI, GB, GD, GE, GH, GM, GT, HN, HR, HU, ID, IL, IN, IS, JP, KE, KG, KM, KN, KP, KR, KZ, LA, LC, LK, LR, LS, LT, LU, LV, LY, MA, MD, MG, MK, MN, MW, MX, MY, MZ, NA, NG, NI, NO, NZ, OM, PG, PH, PL, PT, RO, RS, RU, SC, SD, SE, SG, SK, SL, SM, SV, SY, TJ, TM, TN, TR, TT, TZ, UA, UG, US, UZ, VC, VN, ZA, ZM, ZW.

(84) Designated States (unless otherwise indicated, for every kind of regional protection available): ARIPO (BW, GH, GM, KE, LS, MW, MZ, NA, SD, SL, SZ, TZ, UG, ZM, ZW), Eurasian (AM, AZ, BY, KG, KZ, MD, RU, TJ, TM), European (AT, BE, BG, CH, CY, CZ, DE, DK, EE, ES, FI, FR, GB, GR, HU, IE, IS, IT, LT, LU, LV, MC, NL, PL, PT, RO, SE, SI, SK, TR), OAPI (BF, BJ, CF, CG, CI, CM, GA, GN, GQ, GW, ML, MR, NE, SN, TD, TG).

## Declaration under Rule 4.17:

— as to applicant's entitlement to apply for and be granted a patent (Rule 4.17(ii))

## Published:

— with international search report

[Continued on next page]

## (54) Title: METHOD OF CONTROLLING SYNTHESIS GAS PRODUCTION

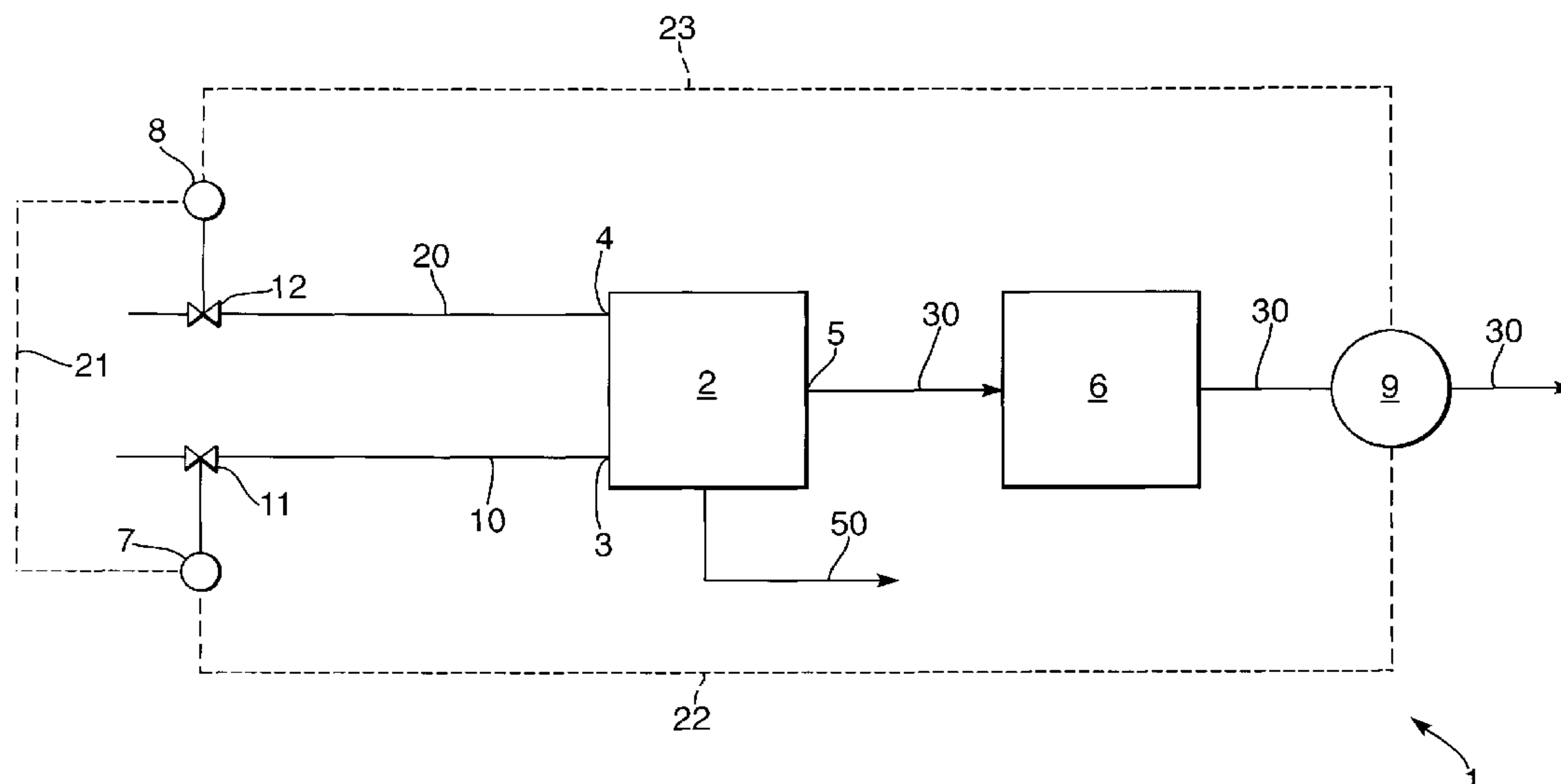

(57) Abstract: The present invention relates to a method of producing synthesis gas by partial oxidation of a carbonaceous stream, wherein the partial oxidation is controlled using an oxygen to carbon ratio (O/C ratio), the method comprising at least the steps of: (a) feeding a carbonaceous stream and an oxygen containing stream into a gasification reactor at a selected O/C ratio; (b) at least partially oxidising the carbonaceous stream in the gasification reactor, thereby obtaining a gaseous product stream at least containing synthesis gas, CO<sub>2</sub> and CH<sub>4</sub>; (c) determining the content of CO<sub>2</sub>, in the product stream obtained in step (b); (d) comparing the content determined in step (c) with a pre-determined content thereby possibly obtaining a difference value between the content determined in step (c) and the pre-determined content; (e) adjusting the O/C ratio in step (a) based on the difference value obtained in step (d).

**WO 2007/068684 A3**



— *before the expiration of the time limit for amending the claims and to be republished in the event of receipt of amendments*

*For two-letter codes and other abbreviations, refer to the "Guidance Notes on Codes and Abbreviations" appearing at the beginning of each regular issue of the PCT Gazette.*

**(88) Date of publication of the international search report:**  
2 August 2007

## METHOD OF PRODUCING SYNTHESIS GAS

The present invention relates to a method of producing synthesis gas by partial oxidation of a carbonaceous stream.

5 Methods for producing synthesis gas by partial oxidation are well known in practice.

Generally, a (hydro)carbonaceous stream such as coal, brown coal, peat, wood, coke, soot, or other gaseous, liquid or solid fuel or mixture thereof, is partially combusted in a gasification reactor (or otherwise  
10 partially oxidised) using an oxygen containing gas such as substantially pure oxygen or (optionally oxygen-enriched) air or the like, thereby obtaining a product stream containing a.o. synthesis gas (i.e. CO and H<sub>2</sub>) and CO<sub>2</sub>.

15 The product stream is usually further processed, e.g. to cool the product stream in a quench section and to remove undesired components. Also, the product stream may be subjected to shift conversion, wet gas scrubbing and the like, depending on the end use of the product stream  
20 or parts thereof.

A problem of the known method of producing synthesis gas is that the quality of the product stream obtained may vary, due to e.g. disturbances or variations in the carbonaceous stream and the oxygen containing stream  
25 being fed to the gasification reactor, the amount of ash in the carbonaceous stream, etc. If for example coal is used as the carbonaceous stream, variations in H<sub>2</sub>O content of the coal may result in altered process conditions in the gasification reactor, as a result of  
30 which the composition of the product stream will also vary. Various methods of controlling a partial oxidation process are known. For example GB-A-837074 describes a

process wherein the carbon dioxide in the product gas of a partial oxidation process is measured to control the steam flow.

5 US-A-2941877 describes a process for controlling the oxygen-to-carbon feed ratio in a partial oxidation reactor. The oxygen-to-carbon feed ratio is controlled by measuring the methane concentration in the product gas using infrared measurement technique. A disadvantage of using methane as the control input is that the signal is  
10 not a sharp signal, making control less accurate.

The above problem is even more pertinent if the end user of (parts of) the product stream desires a constant quality with only very limited variations therein.

15 It is an object of the present invention to at least minimize the above problem.

It is a further object to provide an alternative method for producing synthesis gas.

20 One or more of the above or other objects can be achieved according the present invention by providing a method of producing synthesis gas by partial oxidation of a carbonaceous stream, wherein the partial oxidation is controlled using an oxygen to carbon ratio (O/C ratio), the method comprising at least the steps of:

- 25 (a) feeding a carbonaceous stream and an oxygen containing stream into a gasification reactor at a selected O/C ratio;
- (b) at least partially oxidising the carbonaceous stream in the gasification reactor, thereby obtaining a gaseous product stream at least containing synthesis gas, CO<sub>2</sub> and  
30 CH<sub>4</sub>;
- (c) determining the content of CO<sub>2</sub> in the product stream obtained in step (b);
- (d) comparing the content determined in step (c) with a pre-determined content thereby possibly obtaining a

difference value between the content determined in step (c) and the pre-determined content;

(e) adjusting the O/C ratio in step (a) based on the difference value obtained in step (d).

5 It has been surprisingly found that by controlling the O/C ratio on basis of the content of CO<sub>2</sub> in the product stream, the process conditions in the gasification reactor (such as the gasification temperature) and thereby the quality of the product stream may be controlled in a very simple manner.

10 Applicants further found that the content of CO<sub>2</sub> gives a sharp signal as compared to the signal of CH<sub>4</sub> as measured by infrared, making it more suited to control this process. Applicants further found that controlling the C/O ratio is much more efficient than controlling the steam flow in order to achieve a product stream having a constant quality with only very limited variations therein.

20 According to the present invention, the carbonaceous stream may be any suitable liquid, gaseous or solid stream (including slurries) suitable to be partially oxidised thereby obtaining a synthesis gas containing product stream. The term 'carbonaceous' is meant to also include 'hydrocarbonaceous'. It has been found that the method according to the present invention is especially

25 suitable if as a carbonaceous stream preferably a solid, particulate, high carbon containing feedstock is used. A preferred feed is a solid carbonaceous feed. Examples of such feeds are coal, biomass, for example wood and waste, preferably coal. More preferably the solid carbonaceous

30 feed is substantially, i.e. > 90 wt.%, comprised of naturally occurring coal or synthetic (petroleum) cokes. Suitable coals include lignite, bituminous coal, sub-bituminous coal, anthracite coal, and brown coal. The

35 solid carbonaceous feed may be fed to the process as a

slurry in water or more preferably as a mixture of the feed and a suitable carrier gas. A suitable carrier gas is nitrogen.

5 As oxygen containing stream any suitable stream may be used. Usually substantially pure oxygen (e.g. obtained using an Air Separation Unit) will be used. However, also air or oxygen-enriched air may be used.

10 The person skilled in the art will readily understand how to select the desired selected O/C ratio for a specific carbonaceous stream to be fed in step (a). For the present invention the O/C ratio has the following meaning, wherein 'O' is the weight flow of molecular oxygen, O<sub>2</sub>, as present in the oxygen containing stream and wherein 'C' is the weight flow of the carbonaceous  
15 feed excluding any optional carrier gas or water, in case of a slurry. The desired selected O/C ratio may e.g. be determined using known energy content data for a specific carbonaceous stream such as the heating value of the feedstock in J/kg. Usually, having determined the desired  
20 selected O/C ratio, the O<sub>2</sub> content in the oxygen containing stream will be determined and the suitable flow rates for the carbonaceous and oxygen containing feed streams will be established to obtain the desired O/C ratio.

25 Preferably the content of CO<sub>2</sub> is determined by means of infrared, although other measurement techniques can also be used. The content of CO<sub>2</sub> is preferably measured in the gas stream as close to the partial oxidation step as possible for obvious control reasons. Nevertheless  
30 applicants found that the process can still be effectively controlled when the CO<sub>2</sub> content is measured downstream of a water gas scrubber. This is advantageous because the scrubbed gas will contain fewer acids making the analysis simpler. Also the person skilled in the art  
35 will understand how the determining of the content in

step (c) can be done; therefore this will not be further discussed here.

The comparing of the content of the product stream with the pre-determined content in step (d) may be done by hand. However, normally e.g. a suitable computer program will be used. The pre-determined content usually corresponds to the content of the expected product composition (or an expected content of one or more components thereof) that would have been obtained on basis of the selected O/C ratio if no variations or disturbances would occur. If a difference exists (i.e. the difference value) between the actual content of the product stream and the pre-determined content, then the O/C ratio is adjusted to some extent e.g. by adjusting the flow rates of the feed streams. As a result of the adjusting of the O/C ratio, the process conditions will be changed (and the steps (c) to (e) repeated) until the actual content obtains a desired value.

The person skilled in the art will understand that, if desired, the O/C ratio will only be adjusted if the difference value is above a pre-selected value. Further, the adjustment of the O/C ratio will depend on to what extent the product stream composition deviates from the pre-determined composition.

According to the present invention it has been found that the CO<sub>2</sub> content in the product stream content are especially suitable for comparison purposes. Thus, preferably the difference value possibly obtained in step (c) is obtained on the basis of a comparison between the content of in the product stream and the pre-determined content for CO<sub>2</sub>.

It is preferred according to the present invention that, if a difference value occurs (optionally above a preset value), the O/C ratio is adjusted in step (e) by adjusting the flow rate of one of the carbonaceous stream

and the oxygen containing stream fed in step (a) or a combination thereof. Preferably the carbonaceous stream is adjusted in step (e).

In another aspect the present invention provides a system suitable for performing the method according to one or more of the preceding claims, the system at least comprising:

- a gasification reactor having an inlet for an oxygen containing stream, an inlet for a carbonaceous stream, and downstream of the gasification reactor an outlet for a product stream produced in the gasification reactor;
- a first flow controller for controlling the flow of the oxygen containing stream into the gasification reactor;
- a second flow controller for controlling the flow of the carbonaceous stream into the gasification reactor;
- a quality controller for determining the composition of the product stream and comparing thereof with a pre-determined composition, thereby possibly obtaining a difference value;

wherein the quality controller is functionally coupled with the first and second flow controllers and wherein the quality controller can adjust the flow rates in the first and second flow controllers, based on the difference value.

The invention will now be described by way of example in more detail with reference to the accompanying non-limiting drawing, wherein:

Figure 1 schematically shows a system for performing the method according the present invention.

For the purpose of this description, a single reference number will be assigned to a line as well as a stream carried in that line. Same reference numbers refer to similar structural elements.

Reference is made to Figure 1. Figure 1 schematically shows a system 1 for producing synthesis gas. In a gasification reactor 2 a carbonaceous stream 20 such as coal and an oxygen containing stream 10 such as air may be fed at inlets 4,3, respectively, at a selected O/C ratio. In the shown embodiment of Figure 1, the selected O/C ratio is obtained by the first and second flow controllers 7,8. The first and second flow controllers 7,8 are operatively connected (as indicated by dashed line 21). Furthermore, both first and second flow controllers 7,8 comprise a valve, schematically denoted with reference numbers 11 and 12.

The coal 20 is at least partially oxidised in the gasification reactor 2, thereby obtaining a gaseous product stream 30 at least comprising synthesis gas (i.e. CO + H<sub>2</sub>), CO<sub>2</sub> and CH<sub>4</sub>. To this end usually several burners (not shown) are present in the gasification reactor 2. As coal is used as the carbonaceous stream 20, also a slag is formed which is removed via line 50 for further processing.

Usually, the partial oxidation in the gasification reactor 2 is carried out at a temperature in the range from 1200 to 1800 °C and at a pressure in the range from 1 to 200 bar, usually at 40 bar.

As shown in the embodiment of Figure 1, the produced product stream 30 containing the synthesis gas is fed to a quenching section 6; herein the stream 30 is usually cooled to about 350 °C. The quenching section 6 may have any suitable shape, but will usually have a tubular form.

The person skilled in the art will readily understand that the product stream 30 leaving the quenching section 6 may be further processed. To this end, it may be fed into e.g. a dry solids removal unit (not shown), a wet gas scrubber (not shown), to a shift converter (not shown), etc.

The product stream 30 containing the synthesis gas leaving the quenching section 6, and preferably leaving a further downstream wet gas scrubber, is fed to a quality controller 9, in which the content of CO<sub>2</sub> of the product stream 30 is determined and compared with a pre-determined content of CO<sub>2</sub>. This pre-determined content of CO<sub>2</sub> may e.g. correspond to the expected content of CO<sub>2</sub> of product stream 30 that would have been obtained on basis of the selected O/C ratio if no variations or disturbances would occur.

If the composition of the product stream 30 deviates from the pre-determined content of CO<sub>2</sub>, the O/C ratio of the streams 10 and 20 is adjusted thereby also affecting the process conditions in the gasification reactor 2. The person skilled in the art will understand that, if desired, the O/C ratio may only be adjusted if the deviation (i.e. the difference value) is above a pre-set value.

In order to achieve the desired adjustment of the O/C ratio of the stream 10 and 20, the quality controller 9 operates the flow controllers 7 and 8 (as indicated by the dashed lines 22 and 23) and as a result the flow rates of the streams 10 and/or 20 are adjusted accordingly. As a consequence, the process conditions (in particular the gasification temperature) in the gasification reactor 2 are altered thereby also altering the content of CO<sub>2</sub> of the product stream 30. These adjustments of the O/C ratio may take place as long as the content of CO<sub>2</sub> of the product stream 30 deviates from the pre-determined content of CO<sub>2</sub>.

Hereafter a non-limiting example of the method according to the invention is discussed.

#### Example

Using the line-up as generally shown in Figure 1, synthesis gas was produced by partial oxidation of a

solid, particulate coal stream, which was initially fed into the gasification reactor. As oxygen containing stream substantially pure oxygen (obtained from an ASU) was used.

5           The coal and oxygen streams were fed in order to (tentatively) obtain a selected O/C ratio of about 0,713. After partially oxidising the coal stream in the gasification reactor at a temperature of about 1500 °C and a pressure of about 40 bar, a gaseous product stream  
10 was obtained. The composition of the gaseous product stream was determined and is given in Table I below (indicated as 'actual composition').

          In the Example the content of CO<sub>2</sub> in the product stream was measured by infrared measurement technique and  
15 compared with a (calculated) pre-determined content of CO<sub>2</sub> in the product stream (also indicated in Table I) as a result of which a difference value between the content of CO<sub>2</sub> in the actual composition and the pre-determined composition (in casu 0.74 mol %) was obtained. As the  
20 difference value of CO<sub>2</sub> was deemed too high (exceeding a pre-selected value of e.g. 1% of the predetermined content), the O/C ratio of the coal and oxygen streams fed into the gasification reactor was adjusted by amending the flow rate of the coal stream while keeping  
25 the flow rate of the oxygen stream constant. This was repeated as long as the difference value between the actual content of CO<sub>2</sub> and the predetermined content of CO<sub>2</sub> in the product stream was less than the pre-selected value of 1%.

30           It goes without saying that a pre-selected value different from 1% (such as e.g. 0.5%) may be chosen, if desired. Preferably the pre-selected value is between 0.5 and 5%.

Table I. Composition of gaseous product stream.

Component	Actual composition	Predetermined composition (calculated)	Difference value
H <sub>2</sub> O [mol %]	19.85	19.85	
H <sub>2</sub> [mol %]	19.22	19.55	
CO [mol %]	46.39	46.91	
H <sub>2</sub> S [mol %]	0.38	0.38	
N <sub>2</sub> [mol %]	7.83	7.71	
Ar [mol %]	0.07	0.06	
NH <sub>3</sub> [mol %]	0.01	0.01	
COS [mol %]	0.05	0.05	
HCN [mol %]	0.01	0.01	
CO <sub>2</sub> [mol %]	6.19	5.45	0.74 (*)
CH <sub>4</sub> [mol %]	0.0024	0.0047	0.0023

(\*) This result is a difference value of ~13%, exceeding the pre-selected value of 1%.

The person skilled in the art will readily understand that the present invention may be modified in various ways without departing from the scope as defined in the claims.

CLAIMS:

1. Method of producing synthesis gas by partial oxidation of a carbonaceous stream, wherein the partial oxidation is controlled using an oxygen to carbon ratio (O/C ratio), the method comprising at least the steps of:

(a) feeding a carbonaceous stream and an oxygen containing stream into a gasification reactor at a selected O/C ratio;

(b) at least partially oxidising the carbonaceous stream in the gasification reactor, thereby obtaining a gaseous product stream at least containing synthesis gas, CO<sub>2</sub> and CH<sub>4</sub>;

(c) determining the content of CO<sub>2</sub> in the product stream obtained in step (b);

(d) comparing the content determined in step (c) with a pre-determined content thereby obtaining any difference in value between the content determined in step (c) and the pre-determined content wherein the difference value is expressed as a percentage of the absolute difference between the content of CO<sub>2</sub> in the product stream and the pre-determined CO<sub>2</sub> content relative to the pre-determined CO<sub>2</sub> content;

(e) adjusting the O/C ratio in step (a) when the difference value obtained in step (d) exceeds a pre-selected value and wherein the pre-selected value is between 0.5 and 5%.

- 12 -

2. Method according to claim 1, wherein the carbonaceous stream fed in step (a) comprises particulate coal.

3. Method according to any one of claims 1 to 2, wherein the O/C ratio is adjusted in step (e) by adjusting the flow rate of one of the carbonaceous stream and the oxygen containing stream fed in step (a) or a combination thereof.

4. Method according to claim 3, wherein the O/C ratio is adjusted by adjusting the flow rate of the carbonaceous stream, while keeping the oxygen containing stream constant.

5. Method according to any one of claims 1 to 4, wherein the product stream in step (b) has been subjected to a wet gas scrubbing before performing step (c).

6. Method according to any one claims 1 to 4, wherein in step (c) the content of CO<sub>2</sub> is determined by means of infrared.

7. System (1) suitable for performing the method according to any one of claims 1 to 6, the system (1) at least comprising:

- a gasification reactor (2) having an inlet (3) for an oxygen containing stream (10), an inlet (4) for a carbonaceous stream (20), and downstream of the gasification reactor (2) an outlet (5) for a product stream (30) produced in the gasification reactor (2);

- a first flow controller (7) for controlling the flow of the oxygen containing stream (10) into the gasification reactor (2);

- 13 -

- a second flow controller (8) for controlling the flow of the carbonaceous stream (20) into the gasification reactor (2);
- a quality controller (9) for determining the content of CO<sub>2</sub> of the product stream (30) and comparing thereof with a pre-determined content of CO<sub>2</sub>, thereby obtaining any difference in value;

wherein the quality controller (9) is functionally coupled with the first and second flow controllers (7,8) and wherein the quality controller (9) can adjust at least one of the flow rates in the first and second flow controllers (7,8), based on the difference value.

1/1

Fig. 1.

