

E. F. GILBERT.  
CORNER STRAP FOR CRATES.  
APPLICATION FILED JUNE 4, 1902.

NO MODEL.

Fig. I.

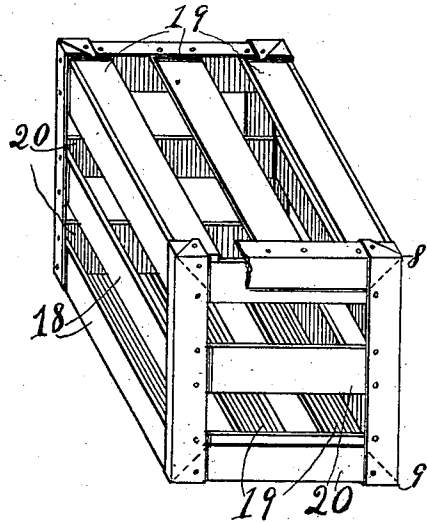

Fig. II.

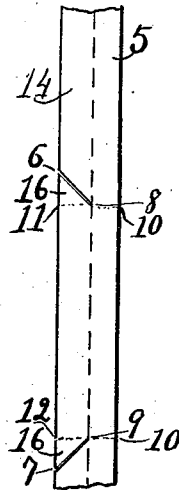

Fig. III.

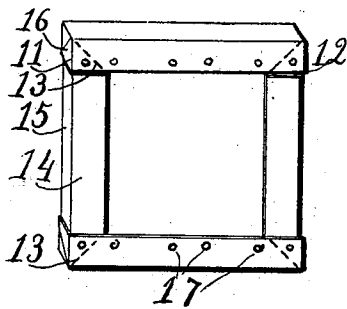
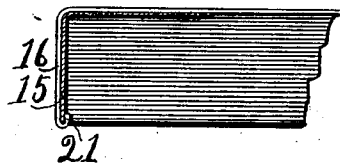

Fig. IV.



Witnesses  
A. E. Waller  
N. Waller.

Inventor  
Edward F. Gilbert  
by W. B. Stevens.  
Attorney

# UNITED STATES PATENT OFFICE.

EDWARD F. GILBERT, OF LYONS, NEW YORK.

## CORNER-STRAP FOR CRATES.

SPECIFICATION forming part of Letters Patent No. 722,692, dated March 17, 1903.

Application filed June 4, 1902. Serial No. 110,209. (No model.)

*To all whom it may concern:*

Be it known that I, EDWARD F. GILBERT, a citizen of the United States, residing at Lyons, in the county of Wayne and State of New York, have invented a new and useful Improvement in Corner-Straps for Crates; and I do hereby declare the following to be a full, clear, and exact description of the same.

This invention relates to that class of devices by means of which the corners of wooden crates, packing-boxes, &c., are strengthened; and its object is to shape straps of hoop metal or similar material so that they may serve as corner-posts and cross-ties for crates and securely bind their own corners.

To this end my invention consists in corner-straps for crates formed as hereinafter more fully described, and particularly pointed out in the claims, reference being had to the accompanying drawings, in which—

Figure I is a perspective view of a crate according to my invention, a portion of the corner-strap being broken away. Fig. II represents a portion of a blank hoop ready to be shaped into one of my corner-straps. Fig. III is a perspective view of one of my corner-straps ready to be applied, but broken at two places to show it in cross-section and turned on its side relatively to Fig. I. Fig. IV is a side view, partly in transverse vertical section, of a strap-corner.

To make one of these straps, a piece of hoop metal 5 is to be sheared obliquely at an angle of about forty-five degrees on lines 6 and 7 to corner-points 8 9, nearly central in the width of the hoop. These corner-points are measured distances apart along the hoop corresponding with the width and height of the crate to be strapped. The hoop is now to be bent into a right-angled trough longitudinally. Then the corners are to be made by a crosswise bend at lines 10, and the strap is finished by bending the laps 16 at lines 11 and 12 against the sides 15 and then turning the points 21 under the edge of the sides to hold thereto like hooks. The dotted lines 13 show the end shape of the under portions 14. The nail-holes 17 may be punched in the hoop by machinery; but hoop metal strong enough for such purposes is still so thin that it may be punched with a wire nail by a hammer-blow. When the strap is completed, as described,

either in square or parallelogram form, it has cuts in one edge only and only one cut for each corner of the crate, and the other edge of the strip remains whole throughout its length. It constitutes a frame for the end of a crate stiff enough to hold the wooden side strips 18, top and bottom strips 19, and end strips 20 when nailed to them, and this it does without the aid of corner-posts of wood.

For the transportation of nice fruits that should not be jammed the corners of the wooden strips may be guarded by a lining of stiff paper in the crate or of thin shaved wood. It is further thought that baskets or boxes of very thin wood could be sufficiently protected by means of these corner-straps to serve for transporting fruit with safety.

When the angular laps over the corners are hooked in place and nailed down, they form bonds that add greatly to the stiffness of the strap-corners, making them very rigid.

By means of these straps crates may be quickly made up from bundles of strips of wood cut to the lengths required. Crates thus made are strong enough for security in transportation, so that they secure a great saving in handling and in freight charges, and are therefore economical as well as simple and easily constructed by any one who can drive a nail. To put on the top or cover slats, it is necessary to leave the joining end of the band open at an upper corner and after inserting the top slats under the two bands or straps then close and nail down that corner of the strap.

Having thus fully described my invention, what I believe to be new, and desire to secure by Letters Patent, is the following:

1. In corner-straps for crates, a strip of thin metal bent into an angular trough and having slits extending from one edge obliquely to the trough angle, both sides of the trough being bent transversely to the line thereof at the inner end of one of the said slits, substantially as described, whereby one end of the cut side overlaps the other end thereof and passing over the corner, overlaps the other side also.

2. A corner-strap for crates comprising an angular trough of hoop metal having a slit obliquely across one of its sides to the angle; a portion of the cut side being bent down

over the transverse corner and secured upon the uncut side, substantially as described.

3. A corner-strap of hoop material bent into the form of an angular trough and this trough  
5 bent into a corner in its line, one of its sides cut to form a pointed end extending across the other or whole side and turned as a hook around the edge thereof.

4. A corner-strap of hoop material bent into  
10 an angular trough which has slits from one edge obliquely to its angle and which is bent into corners across its line at the inner ends

of the said slits, the angular points of the slit side overlapping the whole side as reinforces at the corners substantially as described, 15 whereby the corner-posts and cross-stays comprising the end frame for a crate are formed in one piece of hoop material.

In testimony whereof I affix my signature in presence of two witnesses.

EDWARD F. GILBERT.

Witnesses:

FRED C. PELL,  
GEO. KENT.