

No. 767,155.

PATENTED AUG. 9, 1904.

J. G. V. LANG.
MEANS FOR REGULATING ELECTRIC MOTORS.

APPLICATION FILED FEB. 1, 1904.

NO MODEL.

5 SHEETS—SHEET 1.

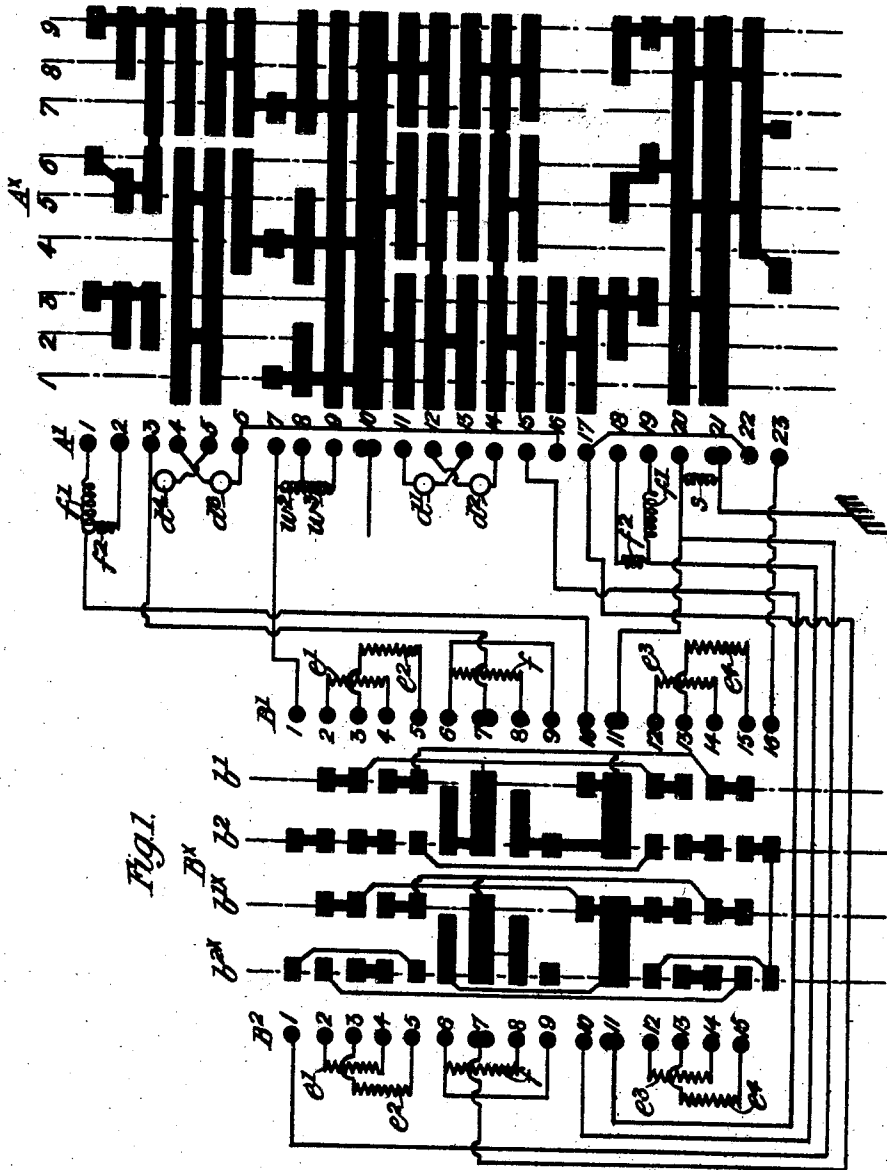

Fig. 1.

Witnessed:
M. J. Keating
A. T. Looney

Inventor:
John Gustaf Viktor Lang
By his Atty.
Charles J. Kintner

J. G. V. LANG.

MEANS FOR REGULATING ELECTRIC MOTORS.

APPLICATION FILED FEB. 1, 1904.

NO MODEL.

5 SHEETS—SHEET 2.

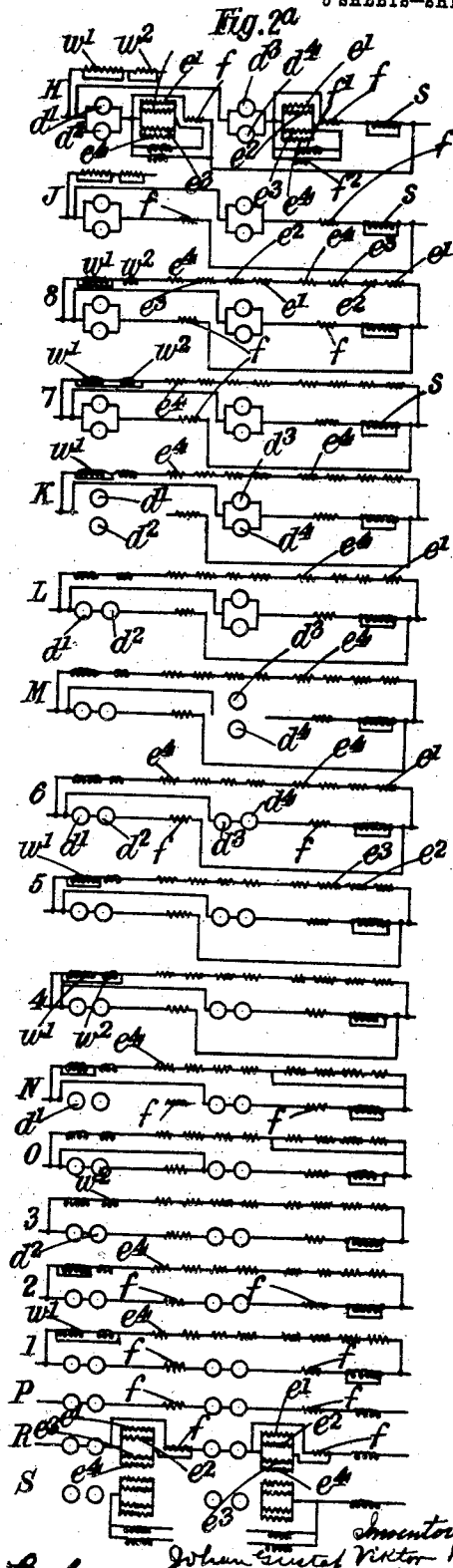
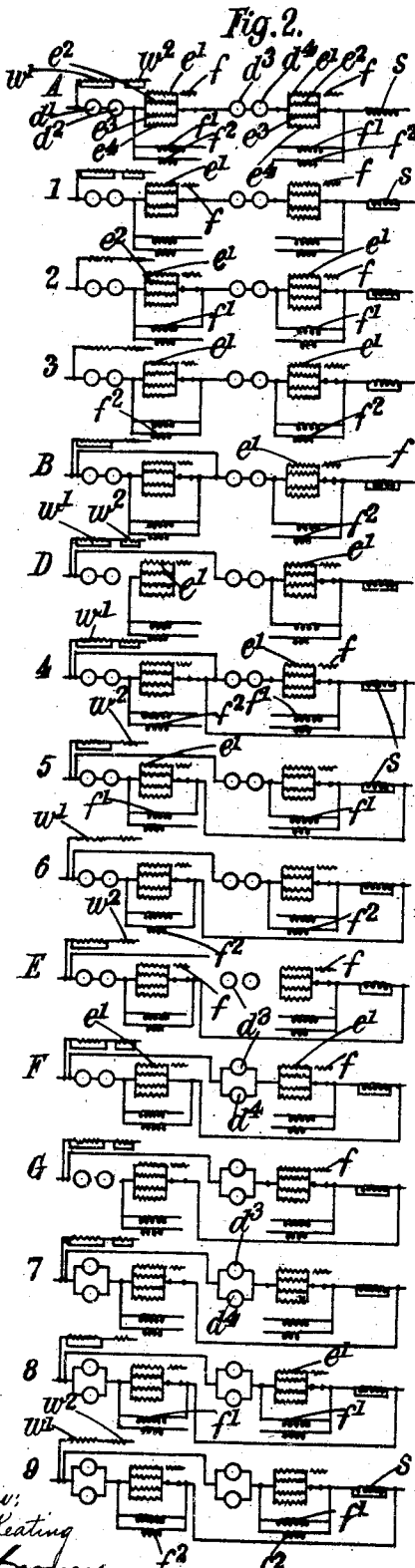

Witness:
 M. J. Keating
 A. F. Rooney

Inventor:
 John Gustaf Viktor Lang
 Charles J. Kintner.
 Payson City.

J. G. V. LANG.
MEANS FOR REGULATING ELECTRIC MOTORS.

APPLICATION FILED FEB. 1, 1904.

NO MODEL.

5 SHEETS—SHEET 3.

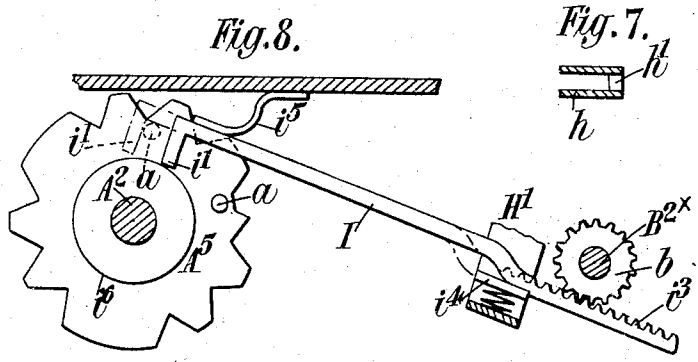
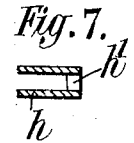
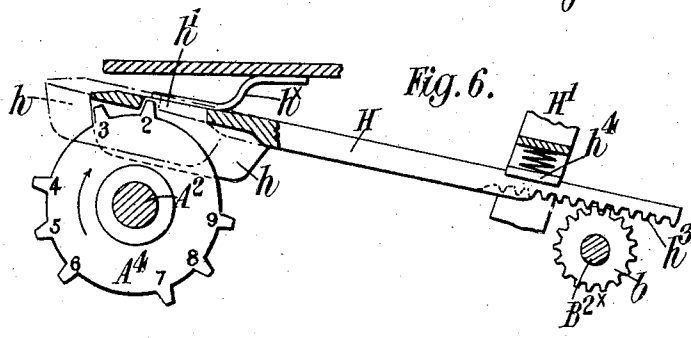
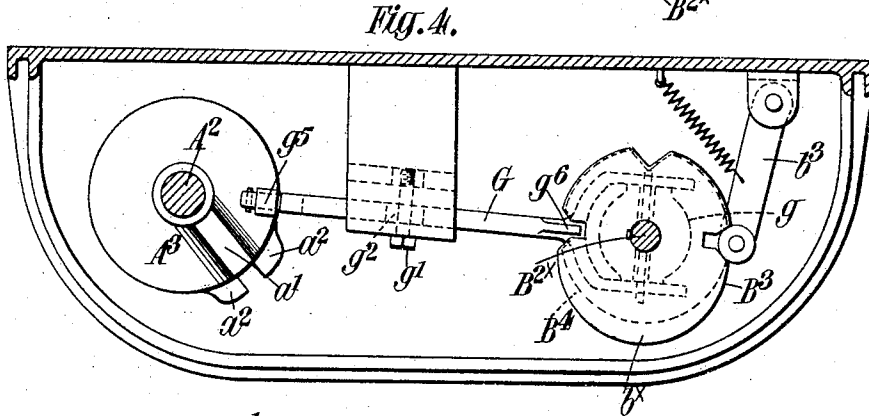
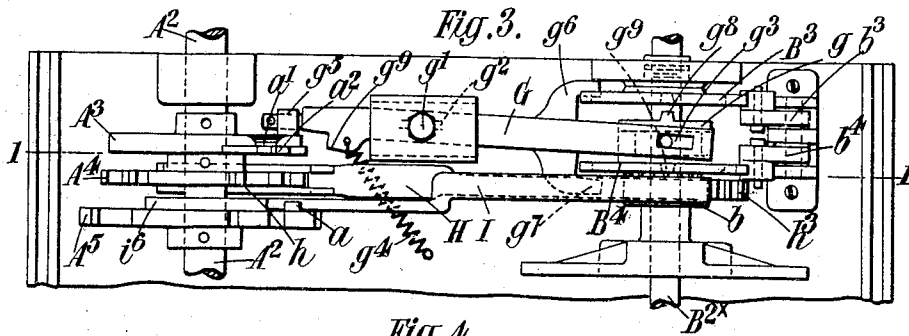

Witnesses:
 M. F. Keating
 A. T. Conroy

Inventor:
 Johan Gustaf Victor Lang
 By his Atty.
 Charles J. Kirtner

J. G. V. LANG.
MEANS FOR REGULATING ELECTRIC MOTORS.
APPLICATION FILED FEB. 1, 1904.

NO MODEL.

5 SHEETS—SHEET 4.

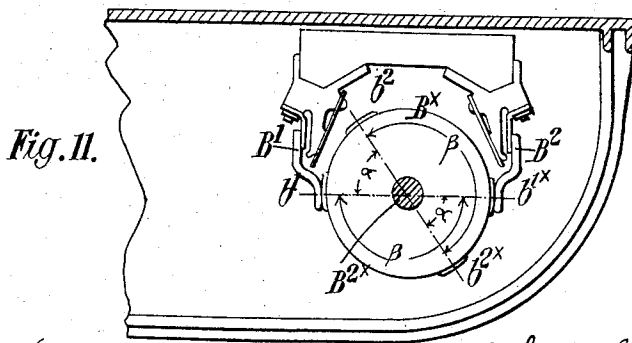
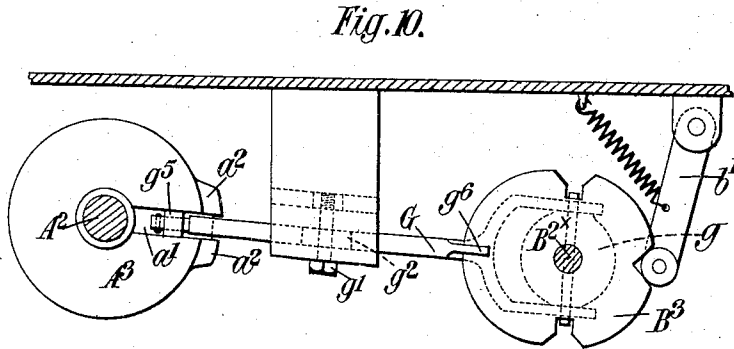
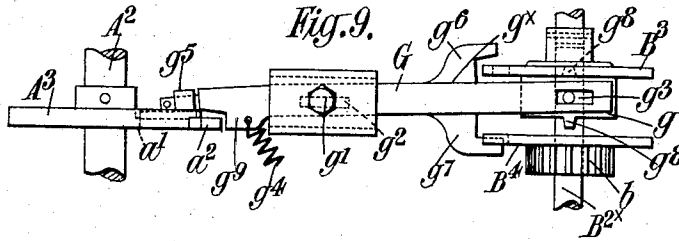
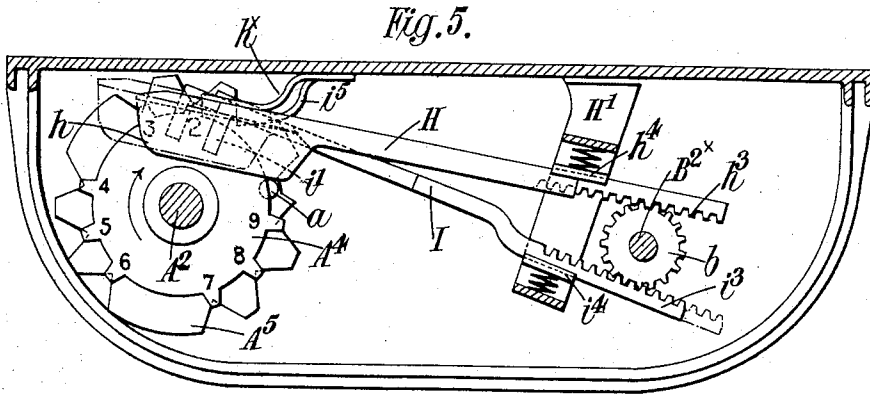

Witnesses:
 M. J. Keating
 A. T. Conroy

Inventor:
 Johan Gustaf Viktor Lang
 By his Atty.
 Charles J. Hinton

J. G. V. LANG.

MEANS FOR REGULATING ELECTRIC MOTORS.

APPLICATION FILED FEB. 1, 1904.

NO MODEL.

6 SHEETS—SHEET 5.

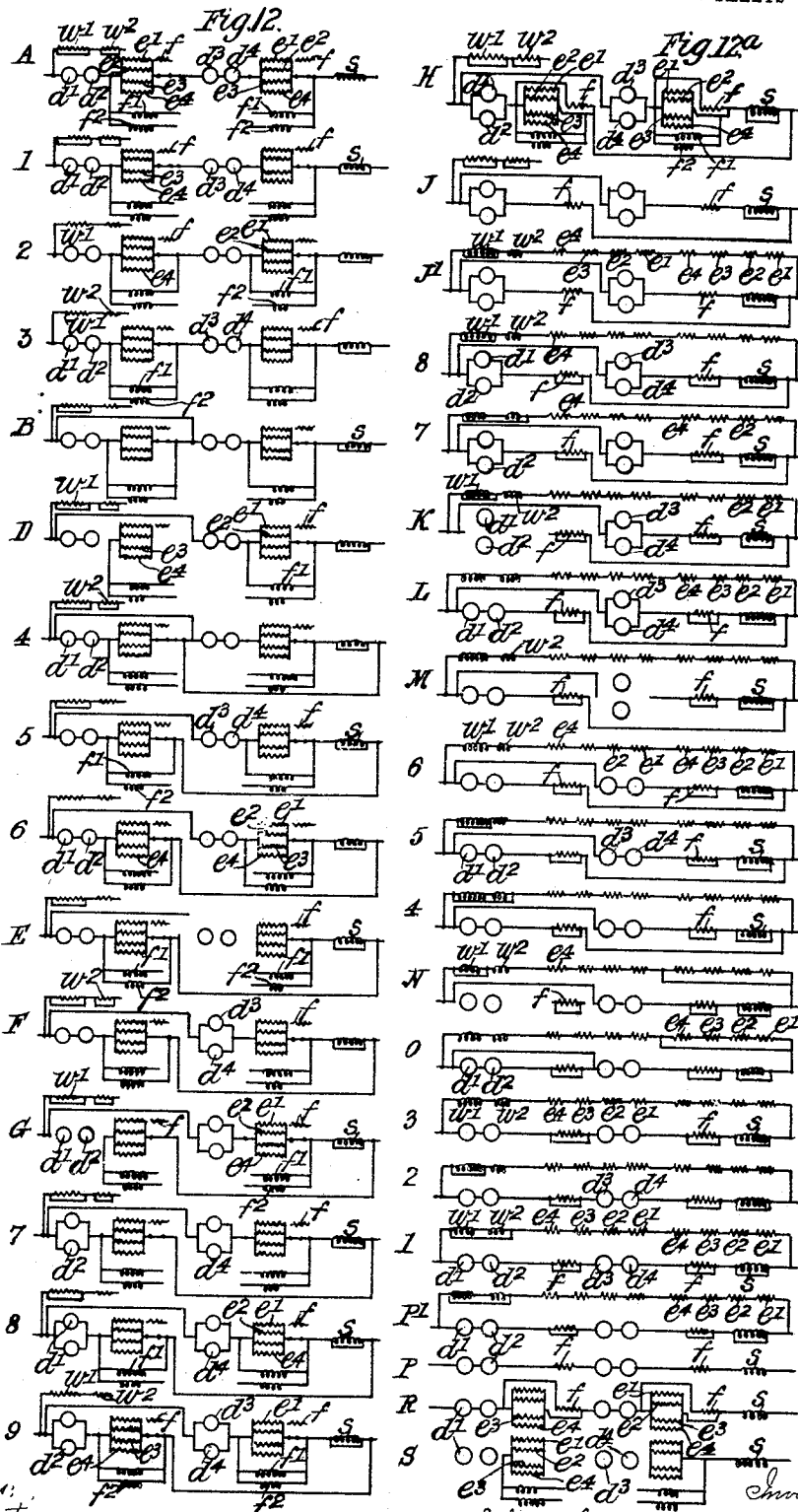

Witnesses:
 M. J. Keating
 A. J. Langney

Inventor:
 Johann Gustaf Viktor Lang,
 by his Atty. Charles J. Kirtner

UNITED STATES PATENT OFFICE.

JOHAN GUSTAF VIKTOR LANG, OF LONDON, ENGLAND, ASSIGNOR OF
ONE-HALF TO EDWARD HIBBERD JOHNSON, OF LONDON, ENGLAND.

MEANS FOR REGULATING ELECTRIC MOTORS.

SPECIFICATION forming part of Letters Patent No. 767,155, dated August 9, 1904.

Application filed February 1, 1904. Serial No. 191,620. (No model.)

To all whom it may concern:

Be it known that I, JOHAN GUSTAF VIKTOR LANG, electrician, a subject of the King of Sweden and Norway, residing at 16^a Soho Square, London, England, have made a new and useful Invention in Means for Regulating Electric Motors, of which the following is a specification.

This invention relates to means for regulating electric motors, particularly those of the kind that are employed for propelling vehicles and that work on a regenerative system in which the motors act as such while propelling and accelerating the vehicle and act as generators for returning electric energy to the source of supply while braking or retarding the vehicle.

In the specification of the previous application for United States Patent, Serial No. 139,817, filed January 20, 1903, there was described a method whereby the series windings of two or more double-wound motors were so constructed and subdivided for the purpose of saving space occupied by the motors and copper used for the windings that said subdivisions could be connected in various parallel relationship and then be used as part of the shunt-winding. For effecting this change from series to shunt, or vice versa, a special field-change cylinder was set forth in said prior specification. It has been found that the aforesaid change when effected by said change-cylinder causes a considerable shock in the motors, which shock is sometimes sufficient to operate the overload-switch of the vehicle, thus causing inconvenience. This shock may be explained by the fact that the strength of the magnetic field of the motors decreases to practically zero at the moment of breaking the field-circuit to change from the series to the shunt condition, or vice versa. As some time is required to enable the field to resume its original strength, it follows that the motor-armatures momentarily revolve in a very weak magnetic field, with the result that the counter electromotive force falls almost to zero, while the voltage remains unchanged, so that in order to balance the difference in voltage between the line-pressure

or power-circuit and the counter electromotive force a rush of current through the motors takes place. According to the present invention this rush of current is avoided by retaining in the circuit of the series field-windings or introducing into such circuit a certain amount of series turns when the series field-winding is broken in changing from the series to the shunt condition (said series turns being, if desired, employed partly or wholly to form the series windings for the compound excitation) and when the shunt field-winding is broken in changing from the shunt to the series condition, still retaining in the said circuit or introducing thereinto a certain amount of series turns, which when the said change has been completely effected—*i. e.*, the full series excitation established—are either totally or partially cut out of circuit or are kept in circuit as part of the complete series field-windings. By this arrangement also not only is the aforesaid rush of current avoided, but the sparking at the contacts of the controller is minimized when the portion of the series field-winding which is formed by the paralleling of the shunt-windings is broken. This reduction of the sparking results from not completely breaking the field-circuit, and therefore not rendering the motors electrically inactive, but, on the contrary, leaving the motor-armatures in circuit and with a magnetic field of considerable intensity for them to revolve in, thereby making this part of the motor control conform with the principle of what is known as "closed-circuit" control. Instead of applying this closed-circuit-control principle only at the times when the field-windings are being changed from series to shunt, or vice versa, it will be found preferable to apply the principle throughout all the changes that are made in the series, series parallel, and parallel relationship of the armatures, as will be hereinafter explained. It should here be stated that for series-wound motors regulated in the usual way by means of resistances in the armature-circuit and simple series paralleling of the field-windings the closed-circuit principle of control is not novel. Neither is it novel to employ the said closed-

circuit principle of control with compound-wound motors in which there are two separate shunt-fields and in which the various combinations of armatures, fields, and resistances are alike for a particular speed-notch of the controller, whether such notch is reached by a forward movement of the controller-cylinder—*i. e.*, from zero toward the highest speed-notch—or by a backward movement of the controller-cylinder—*i. e.*, from the highest speed-notch toward zero. In the present case, however, where the regulation of the speed of the motors is effected by means of changes in the strength of the magnetic field of the motors and where by a backward movement of the controller-cylinder the constitution of the field-windings is radically changed, the application of the closed-circuit principle of control is believed to be novel and for the first time employed in such connection. According to the present invention, also, a further improvement is effected upon the previous method set forth in the aforesaid prior specification by combining in one cylinder the reversing and field-change contacts instead of arranging them on two cylinders, as before, the number of contacts required, especially the stationary contacts, being thus considerably diminished and the dimensions of the controller as a whole greatly reduced. According to another part of the present invention, the said combined reversing and field-change cylinder is so connected with the main-controller cylinder that it will oscillate with the forward-and-backward movement of the main-controller cylinder in order to bring about the change of contacts necessary for causing the motors to assume their series or their compounding condition, but will not be shifted so long as the direction of movement of the main-controller cylinder is not changed. The said main-controller cylinder and the said reversing and field-change cylinder are also furnished with a device whereby the latter cylinder will be caused to assume the position in which its contacts bring about the paralleling or series condition of the field-windings of the motors when the main-controller cylinder assumes the "off" position, so that at the moment of finally breaking the circuit the injurious arcing resulting from breaking the shunt-field will be avoided. The main-controller cylinder is also so arranged that when in its off position the mechanism by means of which the reversing and field-change cylinder is actuated from the main-controller cylinder is rendered inoperative, so as to permit the reversing and field-change cylinder to be independently turned by hand through an angle of one hundred and eighty degrees—*i. e.*, into a position in which the motors, and therefore the vehicle, will be driven in the reverse direction. The handle of the reversing and field-change cylinder is also rendered independent of the oscillating movements of

the said cylinder until the main-controller cylinder has been turned to the off position and until after the said reversing and field-change cylinder has been turned to its paralleling or series position. The said mechanism is provided with interlocking devices for preventing the movement of the handle of the reversing and field-change cylinder until the handle of the main-controller cylinder has been turned into its off position and for preventing the movement of the handle of said main-controller cylinder until the reversing and field-change cylinder has been completely turned through its one-hundred-and-eighty-degree movements in reversing the position of the contacts. By these means the correct relative positions between the main-controller cylinder and the reversing and field-change cylinder will be insured, which is very necessary in a controller of the kind to which this invention relates.

In order that the said invention may be clearly understood and readily carried into effect, the same will be described more fully with reference to the accompanying drawings, in which—

Figure 1 is a diagrammatic development of the various stationary and movable contacts of the improved controller. Figs. 2 and 2^a are diagrammatic representations of the various combinations established by the movements of the cylinders of said controller when the machines are of the compound-wound type, Fig. 2 representing the various combinations when the controller-handle is turned in a forward direction and Fig. 2^a representing the various combinations when the controller-handle is turned in a backward direction. Fig. 3 is a side elevation, and Fig. 4 a plan of the upper part of the said controller, showing the mechanical contrivances with which it is provided for enabling the above-stated actuation and locking of the reversing and field-change cylinder to be effected. Fig. 5 is a horizontal section on the line 1 1 of Fig. 3. Fig. 6 is a sectional plan of the mechanism employed for oscillating the reversing and field-change cylinder from the main-controller cylinder. Fig. 7 is a detail cross-section of the outer end of the lever shown in Fig. 6. Fig. 8 is a sectional plan of the mechanism employed for causing the reversing and field-change cylinder to assume a position in which its contacts bring about the paralleling or series condition of the field windings, when the main-controller cylinder assumes the off position. Fig. 9 is an elevation of the mechanism by which the reversing and field-change cylinder is rendered inoperative by the main-controller cylinder when the latter assumes the off position and is rendered again operative when said main-controller cylinder is shifted from its off position. Fig. 10 is a plan of the mechanism shown in Fig. 9 with the parts in another position. Fig. 130

11 is a horizontal section of the reversing and field-change cylinder and its stationary contacts. Figs. 12 and 12^a are views similar to Figs. 2 and 2^a, showing the various combinations that are established by the movements of the cylinders of the controller when the machines are of the shunt-wound type.

In all the figures like characters of reference indicate similar parts.

10 Referring more particularly to Figs. 1, 2, and 2^a, A^x represents the main-controller cylinder, and A' the stationary row of contacts with which it coöperates, said stationary contacts being numbered from 1 to 23. B^x represents the combined reversing and field-change cylinder, and B' B² are the rows of stationary contacts with which it coöperates, the row B' being numbered from 1 to 15 and the row B² from 1 to 14. The four vertical rows of black squares b' b² b^x b^{2x} represent the various movable contacts with which the said reversing and field-change cylinder B^x is provided. The stationary contacts B' B² are situated on opposite sides of the cylinder B^x, those on one side being connected with the field-windings of one of the two double-wound motors and those on the other side being connected with the field-windings of the other of the two motors. There are nine notches of the controller (represented by the numerals 1 to 9) arranged in three groups, as set forth in the specification of the aforesaid prior application for patent. In the example illustrated there are supposed to be two double-wound electric motors, of which the circles d' d² d³ d⁴ represent the armatures. e' e² e³ e⁴ represent groups or subdivisions of the series windings which are so dimensioned as to enable them to serve as series windings when connected in parallel and as shunt-windings when connected in series. f' f represent other groups or subdivisions of the series windings which are introduced only during the period of regeneration, it being understood that the windings e' to e⁴ when paralleled enable the motors to work like series-wound motors and that when said windings e' to e⁴ are thrown from their paralleled condition to their series condition they enable the motors to work as compound-wound machines. s is the starting resistance, and f' f² are field resistances, the former of which is ohmically higher than the latter. In Figs. 2 and 2^a the letters and numerals on the left-hand side of the diagrams represent the various speed changes and transition steps between such changes, the numerals indicating the speed changes and the letters the transition steps, said transition steps taking place between notches 3 and 4 and notches 6 and 7 when the controller-handle is being turned in a forward direction and between notches 9 and 8, 7 and 6, and 4 and 3 when the controller-handle is being turned in a backward direction. It is to be observed that the same transitions as between

notches 9 and 8 are repeated whenever a change from motor to generator characteristic takes place and similarly that the same transition as between notches and off are repeated whenever a change from generator to motor characteristic takes place.

Referring more particularly to Figs. 2 and 2^a, diagram A shows the two double-wound motors in series connection, the field resistances f' f² and the windings f being disconnected. In this condition of the parts the whole current passes through the windings e' to e⁴ in parallel and the starting resistance s, and the field excitation is at its maximum and the motors are operating to start the vehicle into motion. At diagram 1, Fig. 2, which represents the condition of the motors when the controller-handle is turned to the first or lowest speed-notch for increasing the speed of propulsion of the vehicle, the connections are the same as in diagram A with the exception that the starting resistance s has been short-circuited. At diagram 2, Fig. 2, which represents the condition of the motors when the controller-handle is turned to the second speed-notch, the connections differ from diagram 1 only to the extent that the high resistances f' are put in circuit, thus diverting part of the current from the field-windings e' to e⁴ and weakening the field. At diagram 3, Fig. 2, (the next succeeding speed-notch,) more of the current is diverted from the field-windings e' to e⁴ than in diagram 2 by the introduction into the circuit of the other resistances f², thus still further weakening the field excitation. In effecting the change of speed from notch 3 to notch 4 the motors are changed from their series connection to their series parallel connection by two transition steps (diagrams B and D)—that is to say, the field of one motor is first strengthened, as at diagram B, by cutting out the resistance f² and then the other motor, with its two armatures and field-windings, is short-circuited, as is generally done, and almost simultaneously the circuit through the armature and field-windings of the short-circuited motor is broken, as at diagram D, thus leaving one motor to do all the work. At diagram 4, Fig. 2, (the next succeeding speed-notch,) the short-circuited motor in diagram D is reintroduced, with maximum field strength in parallel with the other motor, the field of which latter is simultaneously strengthened to its maximum by breaking its field resistances f' f². At diagram 5, Fig. 2, (the next succeeding speed-notch,) the maximum field strength of the motors in diagram 4 is weakened by the introduction of the high resistances f', as in diagram 2. At diagram 6, Fig. 2, (the next succeeding speed-notch,) the field strength of the motors is slightly decreased by substituting for the high resistances f' in diagram 5 the low resistances f². In effecting the change of speed from notch 6

to notch 7 the motors are changed from their series parallel connection (in which they existed in diagrams 4, 5, and 6) to full parallel connection by three transition steps (diagrams E, F, and G)—that is to say, the circuit connections of one motor and its field are first broken, as at diagram E, leaving the other motor undisturbed. The disconnected motor, with its armatures in parallel and with maximum field strength, is then reintroduced, as at diagram F, and afterward the other motor is disconnected, as at diagram G, and rearranged and reintroduced, with its armatures in parallel and with maximum field strength, thus bringing about the arrangement indicated at diagram 7, Fig. 2. At diagram 8, Fig. 2, (the next succeeding speed-notch,) the field strength of both motors is weakened by the introduction of the high resistances f' , and at diagram 9, Fig. 2, (the next and last succeeding speed-notch,) the field strength of both motors is further weakened by the introduction of the low resistances f'' in addition to the said resistances f' . When the controller-handle is turned backward, the reversing and field-change cylinder B^x is shifted angularly through the angle α , (sixty degrees,) thus moving its contacts b' and b'^x away from the rows of stationary contacts $B' B^2$ and bringing its contacts $b^2 b^{2x}$ into engagement therewith. This movement of the cylinder B^x causes the contacts 6 and 8 of the rows of stationary contacts $B' B^2$, Fig. 1, to engage with the contacts of the cylinder B^x , this engagement taking place before the other stationary contacts of the rows $B' B^2$ break connection with the rotary contacts b' and b'^x . By the aforesaid change of contacts effected by the angular movement of the cylinder B^x through the sixty degrees a certain amount of series turns f , Figs. 1, 2, and 2^a, are introduced, with the result that the connections are as represented in diagram H, Fig. 2^a. By the continued backward movement of the controller-handle a moment later the field-windings consisting of the paralleled groups e' to e^4 are broken and only the field-windings f remain in circuit, as shown in diagram J. As soon as the rotary contacts $b^2 b^{2x}$ of the cylinder B^x have made contact with the stationary rows of contacts $B' B^2$ the groups of field-windings e' to e^4 are connected together in series and, together with the windings f , convert the machines into their compound condition, as represented at diagram 8, Fig. 2^a, without interrupting the circuit through the armatures, the shunt resistance w' being short-circuited and the shunt resistance w^2 retained in circuit. At diagram 7, Fig. 2, the field strength is increased by short-circuiting both the shunt resistances $w' w^2$. In changing back from the full-parallel to the series-parallel condition of the motors the armature-circuit of one motor is broken, as at diagram K, leaving the shunt-field of the

same in circuit and the resistance w' is short-circuited. Then the armatures of the disconnected motor are rearranged and reintroduced into the circuit, as at diagram L, both of the shunt resistances $w' w^2$ being then in circuit. The same operation of breaking and reintroducing the other motor is repeated, as shown in diagram M and diagram 6, Fig. 2^a, thus bringing about the series-parallel condition of the motor. At diagram 5, Fig. 2^a, (where the controller-handle has been turned back another speed-notch,) the shunt resistance w' is cut out of circuit to strengthen the shunt-winding, and at diagram 4, Fig. 2^a, (where the controller-handle has been turned back another speed-notch,) the other shunt resistance, w^2 , is also cut out of circuit to still further strengthen the shunt-winding. In passing from the series-parallel to the series condition it is necessary to short-circuit one motor at the moment it is being introduced in series with the other. To effect this without developing a dangerous short-circuiting current, the field must be reduced as much as possible. Therefore at the moment of breaking the circuit of one motor in leaving the series-parallel condition its shunt-field is short-circuited, as at diagrams N and O, a suitable resistance being at the same time introduced in the field of the other motor, as shown in these diagrams, to prevent an excessive development of its field strength. Thus the speed-notch represented by diagram 3, Fig. 2^a, is reached, the continued backward movement of the controller-handle bringing about the cutting out of the circuit of first one and then the other of the shunt resistances $w' w^2$ as speed-notches 2 and 1 are reached, as represented in diagrams 2 and 1, Fig. 2^a. The continued backward movement of the controller-handle causes the shunt-windings to be broken, as at diagram P, and to be reintroduced in their series condition, as at diagram R, and eventually breaks the connections when the said controller-handle reaches the off position, as represented in the diagram S.

It is to be remarked that in passing through the various speed steps during the backward movement of the controller-handle, Fig. 2^a, no change takes place in the series field. In the shunt-field the resistances are short-circuited until the armature combination has been changed, (see diagrams 7 and 4,) whereupon the said shunt resistances $w' w^2$ are successively reinserted, thus weakening the field—that is to say, at speed-notches 8, 5, and 2, Fig. 2^a, one resistance—viz., w^2 —is in series with the shunt-field, the other resistance—viz., w' —being short-circuited. At speed-notches 7, 4, and 1, Fig. 2^a, both of the shunt resistances $w' w^2$ are short-circuited, and at speed-notches 6 and 3, Fig. 2^a, both of the said resistances $w' w^2$ are in series with the field-windings. The transition steps shown by diagrams P and R are typical transitions for

changing the field from the shunt to the series condition. The shunt-field is first broken, leaving the series turns in circuit, (diagram P.) The shunt windings e' to e^4 are then rearranged—i. e., converted into the parallel condition—and reintroduced as series windings in parallel with the other series windings f' , (diagram R.) Then these series windings f' are entirely removed from the circuit, (diagram S,) and at the same time the armature and field connections are broken by the controller-handle reaching the off position.

The flow of the current through the various connections will now be traced in connection with Fig. 1. For this purpose let it be assumed that the controller-handle occupies the speed-notch 3, where the motors will be in the condition represented by diagram 3 of Fig. 2 and operating to propel the vehicle. The row of rotary contacts b' of the cylinder B^x will then be in contact with the row of stationary contacts B' , and the row of rotary contacts b'^x of said cylinder B^x will be in contact with the row of stationary contacts B^2 , as represented in Fig. 11, it being understood that the main-controller cylinder A^x will be occupying a position in which its row of contacts 3 will be in contact with the stationary row of contacts A' , Fig. 1. Then the current will flow from the trolley-contact 10 through the main-cylinder contacts to contact 11, through armature d' , contact 13, and main-cylinder contacts to contact 12, armature d^2 , contact 14, then through the main-cylinder contacts to contact 15 and contact 11 of the row of stationary contacts B^2 . Here the current divides, part of it passing to contact 10 (row B^2) and thence through the resistances f' f^2 to contacts 18 and 19 of row A' , whence it passes through the main-cylinder contacts to contact 17 of row A' . The other part of the current passes through the row of contacts b'^x of cylinder B^x to the stationary contacts 2, 3, 12, and 13 of row B^2 and passes simultaneously through the field-windings e' e^2 e^3 e^4 belonging to the armatures d' d^2 and returns to the contacts 4, 5, 14, and 15 of the row B^2 and unites again at contact 7 of said row B^2 . From this contact 7 the current returns to the main cylinder A^x through contact 17 of row A' , where it unites with the part from contacts 18 and 19 and passing over the main-cylinder contacts reaches contact 16 and thence flows to contact 6 of row A' . The current then flows through armature d^3 to contact 4 of row A' , and from this contact it flows through the contacts of the main cylinder A^x to the contact 5 of row A' and thence through armature d^4 and contact 3 of row A' , which is electrically connected with contact 7 of the stationary row of contacts B' . Here the current again divides, part of it passing through the row of contacts b' of the cylinder B^x and reaching the contacts 2, 3, 12, and 13 of row B' , the other part passing through the field-

windings e' e^2 e^3 e^4 belonging to the armatures d^3 d^4 of the motors and returning through contacts 4, 5, 14, and 15 of row B' and uniting again at contact 11 of row B' . Thence the current flows to contact 20 of row A' and through the contacts of main cylinder A^x reaches contact 21 and flows to earth. The current also passes through the resistances f' f^2 of the other motor and reaches the contact 10 of row B' . It then flows through the contacts b' of cylinder B^x to contact 11 of row B' and unites with the other part of the current at contact 20 of row A' and also reaches earth through contact 21. Let it now be assumed that the controller-handle is turned in a backward direction from the speed-notch 3 to speed-notch 2 in order to bring about the retarding or braking of the vehicle, or, in other words, to change the series condition of the motors to their compounding condition, so that they will act as generators and return current to the main supply. Their condition will then be as shown at diagram 2 of Fig. 2^a, and the flow of the current will be as follows, it being understood that the cylinder B^x is then in the position in which its contacts b^2 and b^{2x} are respectively in contact with the rows of stationary contacts B' B^2 and the main cylinder A^x is in the position in which its contacts 2 are in contact with the row of contacts A' : The current passes through contact 10 of row A' to contact 11 of said row and thence flows through armature d' , contact 13, (row A'), contact 12, (row A'), armature d^2 , and contact 14 (row A') to contact 15, (row A'). Thence the current flows to contact 11 of row B^2 , and here it finds only one path of contacts on cylinder B^x to follow. Hence it flows to contact 6 of row B^2 . Thence the current flows through the series windings f' of one of the motors to contact 8 of row B^2 , and thence it passes through the contacts of cylinder B^x to contact 7 of row B^2 . From this contact the current returns to contact 17 of row A' and reaches contact 16 of said row. Thence the current flows to contact 6, (row A'), through armature d^3 , contacts 4 and 5, (row A'), and armature d^4 to contact 3, (row A'). The current then passes to contact 7 of row B' and reaches contact 6, (row B'). It then passes through the series windings f' of the other motor and reaches the contact 8 of row B' . Thence it flows to contact 11 of row B' and passes to contacts 20 and 21 of row A' , and thus to earth. At the same time current flows from contact 10 of row A' to contact 8 of said row and passes through the resistance w^2 to contact 7 of row A' . The current then flows to contact 1 of row B' and thence passes to contact 2 of said row through the field-winding e' to contacts 4 and 3, field-winding e^2 , contacts 5 and 12, field-winding e^3 , contacts 14 and 13, and field-winding e^4 to contact 15. Thence the current passes to contact 12 of row B^2 and through field-winding e^3 to contacts 14

and 13 of said row, thence passing through field-winding e^1 to contacts 15 and 2, (row B^2 .) thence through field-winding e^1 to contacts 4 and 3, and thence through field-winding e^2 to contact 5. Then the current passes to contact 1, (row B^2 .) whence it flows to contacts 20 and 21 of row A, and thus to earth. The direction of the flow of current is the opposite if the counter electromotive force of the motors is higher than the line voltage.

When the motors are shunt-wound, the different variations in their character and electrical relationship during working is illustrated in Figs. 12 and 12^a. In view of the full explanation given with respect to Figs. 2 and 2^a it is unnecessary to describe Figs. 12 and 12^a in detail.

Reference will now be had to Figs. 3 to 11, illustrating the mechanical contrivances of the controller. The main-controller cylinder A^x is mounted on a shaft A^2 , and the combined reversing and field-change cylinder B^x is mounted on a shaft B^{2x} , these shafts being arranged vertically and parallel to one another. The four rows of contacts carried by the said cylinder B^x are arranged in pairs of vertical rows $b^1 b^{2x}$, $b^3 b^{2x}$, situated diametrically opposite each other, Fig. 11. By the angular movement of the shaft B^{2x} each of the two rows of these contacts can be in turn brought into simultaneous engagement with the two rows of stationary contacts $B^1 B^2$. The group or pair of contacts $b^1 b^{2x}$ serves to connect the separate field-windings of the motors in parallel, Fig. 2, so that the machines work as series motors, and the other group or pair of contacts $b^3 b^{2x}$ serves to connect said windings in series, Fig. 2^a, so that the machines work as compound generators. The angular distance α between the two groups of contacts $b^1 b^2$ and $b^3 b^{2x}$ is only that which is necessary to insure the breaking of the arc of one group of contacts before making contact with the other group, and the angular distance β between the groups of contacts $b^1 b^{2x}$ and $b^3 b^{2x}$ is one hundred and eighty degrees. The circuits controlled by these contacts are so arranged that when the cylinder B occupies the position represented in the drawings the motor will revolve in one direction and that when said cylinder is turned through the angle β (*i. e.*, one hundred and eighty degrees, or a half-revolution) to bring the cylinder-contacts that are represented on the left into the position occupied by those on the right the motors will revolve in the opposite direction. This angular displacement of the cylinder in no wise interferes with the capacity of the cylinder-contacts to bring about the change of the field-windings of the motors from the series to the compound condition, and vice versa, when said cylinder is oscillated through the angle α in whichever of the two extreme positions it may be placed by turning through the said angle β —that is to say, when one

group of contacts (say $b^1 b^{2x}$) engages with the stationary contacts $B^1 B^2$ the windings of the motors will be in paralleled condition and form part of the series windings, and when the other group of contacts (say $b^3 b^{2x}$) engages with said stationary contacts the windings will be in the shunt or compounding condition, this function of the contacts being equally well fulfilled by the oscillation from one group of contacts to the other through the angle α , irrespective of the one-hundred-and-eighty-degree position of the cylinder, and therefore independently of the direction of rotation of the motors. The oscillation through the angle α from one row or group of contacts to the other cannot effect a reversal of the current through the fields of the motors, since that requires the movement of the cylinder through the angle β —*i. e.*, one hundred and eighty degrees. The shaft A^2 has fixed thereon three superposed disks $A^3 A^4 A^5$, and the shaft B^{2x} has loosely mounted thereon two superposed disks $B^3 B^4$, the last-mentioned disk B^4 forming part of a toothed pinion b . g is a clutch connected with the shaft B^{2x} by a groove and feather, so as to be capable of revolving with the shaft B^{2x} and also of sliding thereon under the action of a lever G and of thereby locking either the disk B^3 or the disk B^4 to the shaft B^{2x} in accordance with the position of the lever. H is a sliding arm or rod having a channel-shaped end h , which embraces the periphery of the disk A^4 under the action of a spring h^x . This disk also has teeth 2 to 9 on its periphery, which teeth are arranged to correspond with the positions 2 to 9 of the several speed-notches of the main controller. The said channel-shaped end of the sliding arm H is formed with a slot h' , Fig. 6, which under the action of the spring h^x , that tends to press the channel-shaped end toward the disk A^4 , is caused to engage with the teeth as they one by one become coincident therewith. The other end of this arm or rod H has rack-teeth h^3 , which by the action of a spring-controlled presser plate or block h^4 , working in a guide-piece H^1 , is kept in constant engagement with the pinion b . In the position in which the parts are represented by the full lines in Figs. 5 and 6 the pinion is supposed to be clutched to the shaft B^{2x} of the reversing and field-change cylinder, and the controller-shaft A^2 and its disk A^4 are supposed to have been turned in the direction of the arrow, with the result that the said arm or rod H has been moved inwardly and has turned the pinion b , together with the shaft B^{2x} and the reversing-cylinder, into the position required for bringing about the propelling or series condition of the motors. The parts being in this position, it will be seen that if the turning of the main-controller shaft A^2 be continued in the same direction as that indicated by the arrow no further motion will be imparted to the shaft B^{2x} of the reversing

and field-change cylinder, by reason of the fact that as each of the teeth 2 to 9 of the disk A^4 passes beneath the outer end of the arm or rod H it will only operate to raise the said outer end against the resistance of its spring h^x . On the other hand, if the said disk A^4 should be turned in the reverse direction to that indicated by the arrow the tooth—say 2—which is for the time being in engagement with the slot h' will strike against the adjacent end of said slot and in continuing its movement will thereby push the arm or rod H outwardly until it assumes the position indicated by the dotted lines in Figs. 5 and 6. This movement of the arm or rod H has the effect of turning the pinion b in the direction necessary for angularly displacing the reversing and field-change cylinder through the angle α and for bringing the motors into the braking or compounding condition. The said arm or rod H having assumed this position, any further motion of the disk A^4 in the said direction will not cause the arm or rod to be actuated otherwise than by its being lifted by the teeth 2 to 9 as they successively pass beneath it, as explained above, when the said arm or rod was in the position represented by the full lines. Immediately, however, the said shaft A^2 is turned in the reverse direction again—*i. e.*, in the same direction as that indicated by the arrow—the tooth which is for the time being engaging in the slot h' will push against the adjacent end of said slot and in that way cause the arm or rod to slide inwardly, thereby setting the reversing and field-change cylinder again into the position for causing the motors to assume their propelling or series condition. I is another sliding arm or rod situated beneath the arm or rod H and having rack-teeth i^3 at its inner end to engage with the pinion b on the side opposite to that at which the rack-teeth on the arm or rod H engage with the pinion. This arm or rod I is kept in engagement with said pinion b by a spring-controlled presser plate or block i^4 , mounted in the said guide-piece H' . The outer end of said arm or rod I is formed with a lip or flange i' , Fig. 8, which by the action of a spring i^5 is retained in the path of a pin or stud a , carried by the upper face of the disk A^5 , a collar i^6 being provided on the shaft A^2 for the said lip i' to press against, and thereby limit the extent to which the rod I can be pushed by said spring i^5 . The position of this pin or stud a relatively to the flanged end i' of the sliding arm or rod I is such that when the shaft a^2 of the main-controller cylinder is turned to the off position the said pin or stud will strike said flanged end i' and shift the arm or rod I outwardly, as represented by the dotted lines in Fig. 8, thereby causing the pinion b and its shaft B^{2x} to turn in a direction to bring the reversing and field-change cylinder into a position in which its contacts cause the motors to assume their paralleling or series condition,

so that the shunt field-windings will be broken by the cylinder B^x at the several contacts thereon instead of only at one or two points on the main-controller cylinder, as aforesaid. It is to be understood that the movement of either of the said sliding arms or rods H and I imparts movement in the reverse direction to the other of said arms or rods through the pinion b , the parts being so arranged that these movements can take place without impediment. The said lever G, which actuates the clutch g , is pivoted at g' and is also capable of sliding longitudinally on its pivot, for which purpose it has slots $g^2 g^3$, Fig. 9. A spring g^4 keeps the end g^5 in constant contact with the upper surface of the disk A^3 . This disk has a depression or is notched at a' , Figs. 4 and 10, and the adjacent walls at the sides of the depression or notch are inclined. The position of the said depression or notch is such that it will come beneath the end g^5 of the lever when the main-controller cylinder is turned into the off position, and then the end g^5 of said lever will enter said depression or notch under the action of the spring g^4 . As a consequence the opposite end of the lever G will ascend and carry the clutch g out of engagement with the disk B^4 and pinion b and will bring it into engagement with the disk B^3 . At the same time projections or stops $g^6 g^7$ on the said lever G will come into such a position that the stop g^6 will be disengaged from the notched disk B^3 and the stop g^7 be engaged with the notched disk B^4 , that forms part of the pinion b . When the parts are in this position, the shaft B^{2x} of the reversing and field-change cylinder can be turned independently of the main-controller cylinder through the angle β , so as to place the contacts in proper position for reversing the direction of rotation of the motors. As seen, as the main-controller cylinder is turned from its off position the disk A^3 rotates and carries the depression or notch a' from beneath the end g^5 of the lever G, thus elevating this end and causing the opposite end to descend, thereby bringing the clutch into reengagement with the pinion b , so that it is not possible to actuate the reversing and field-change cylinder except through the agency of the main-controller cylinder. The aforesaid stops $g^6 g^7$ (when the lever G assumes the position indicated in Fig. 3) operate to release the notched disk B^4 , forming part of the pinion b , and to lock the notched disk B^3 , so that the handle by which the shaft B^{2x} of the reversing and field-change cylinder is operated cannot at such time be turned, nor will it be capable of being turned until the depression or notch of the disk A^3 occupies a position beneath the end g^5 of the lever G. The stops $g^6 g^7$ do not release the corresponding disks $B^3 B^4$ until one or other of the projections g^8 of the clutch have entered the corresponding grooves in the said disks. The said disk A^3

is also furnished with lugs $a^2 a^3$ adjacent to the depression or notch a' , so that when the end g^5 of the lever G descends as aforesaid, Fig. 9, under the action of the spring g^4 a rectangular portion g^3 of said lever will lie opposite the said lugs. As the handle of the reversing and field-change cylinder is actuated in causing said cylinder to turn through the angle β for reversing the motors, an eccentric part b^x of the said disk B³ will act upon the lug g^x , carrying stop g^6 of the lever G, and thus will force the latter longitudinally into a position in which the rectangular portion g^3 of said lever will engage with the lugs a^2 , Fig. 10, so that the disk A³, and therefore the main-controller cylinder, cannot at such time be actuated nor will they be capable of being actuated until the said eccentric part b^x moves away from the lug g^x and permits the lever G to move longitudinally into its original position under the action of the spring g^4 . The said notched disks B³ B⁴ are prevented from unintentional movement on their shaft by spring-controlled retaining-pawls $b^3 b^4$.

No claim is made hereinafter to the methods of operation by which the results attained by the apparatus hereinbefore described and hereinafter claimed are effected, as this feature constitutes the subject-matter of a divisional application filed by me in the United States Patent Office on the 30th day of April, 1904, bearing Serial No. 205,717.

What I claim, and desire to secure by Letters Patent of the United States, is—

1. In a plurality of electric motors the combination with means for changing the field-windings to render the motors operative either as series-wound motors for propelling and accelerating, or as compound-wound or shunt generators for braking or retarding, of means for keeping the current from the power-circuit uninterrupted while the aforesaid changes in the condition of the field-windings are being effected.

2. In a plurality of electric motors the combination with groups of coils comprising the field-windings, of means for changing the relationship of said coils from a paralleled condition, in which they serve as series windings, to a series condition, in which they serve as shunt-windings, and of means for keeping the current from the power-circuit through the armature-windings and some of the coils of the field-windings uninterrupted while the aforesaid changes in the relationship of the coils are being effected.

3. In a plurality of electric motors the combination with groups of coils comprising the field-windings, of a controller for regulating the speed and direction of revolution of the motors, of means whereby a backward movement of said controller changes the relationship of said coils from a paralleled condition to a series condition and vice versa, and of means for keeping the current from the

power-circuit uninterrupted through the armature-windings while the aforesaid changes in the relationship of the coils are being effected.

4. In a plurality of electric motors the combination with paralleled groups of coils comprising the field-windings, of a main-controller cylinder for regulating the speed of the motors, an auxiliary cylinder for controlling the direction of revolution of the motors, additional means whereby a change from a higher to a lower speed notch of the controller causes the paralleled relationship of said coils to be changed to a series relationship and vice versa, and means for keeping the current from the power-circuit through the armature-windings uninterrupted during any change of field strength or of relationship of the armatures, irrespective of whether the motors are acting as series-wound motors or as compound or shunt wound generators, and while being changed from one to the other of those conditions.

5. In a plurality of electric motors, the combination with the groups of coils comprising the field-windings, of a main-controller cylinder having contacts for regulating the speed of the motors, a cylinder provided with contacts for regulating the field-changes of the motor-windings from the series to the compound or shunt condition and vice versa and having contacts for reversing the direction of rotation of the motors, and means for actuating said field-change and reversing cylinder.

6. In a plurality of electric motors the combination with the groups of coils comprising the field-windings, of a main-controller cylinder having contacts for regulating the speed of the motors, stationary contacts with which the main-controller cylinder contacts cooperate, a cylinder provided with contacts for regulating the field changes of the motor-windings and with contacts for reversing the direction of rotation of the motors, stationary contacts with which the contacts of the field-change and reversing cylinder cooperate, means for turning said field-change and reversing cylinder through small angles for changing its field-contacts when the direction of movement of the main-controller cylinder is changed at any particular speed-notch, and means for turning said field-change and reversing cylinder through large angles for changing its reversing-contacts when the direction of rotation of the motors is to be changed.

7. In a plurality of electric motors the combination with the groups of coils comprising the field-windings, of a main-controller cylinder having contacts for regulating the speed of the motors, stationary contacts with which the main-controller-cylinder contacts cooperate, a cylinder provided with contacts for regulating the field changes of the motor-windings and with contacts for reversing the direction of rotation of the motors, stationary

contacts with which the contacts of the field-change and reversing cylinder cooperate, means operative from the main-controller cylinder for turning said field-change and reversing cylinder through small angles to change its field-contacts when the direction of movement of the main-controller cylinder is changed at any particular speed-notch, means for turning said field-change and reversing cylinder through large angles independently of the main-controller cylinder, means for automatically preventing the movement of the main-controller cylinder during the large angular movements of the field-change and reversing cylinder, and means for automatically preventing the movement of the field-change and reversing cylinder from the exterior of the controller until the main-controller cylinder has been turned to the "off" position, substantially as and for the purposes specified.

8. In a plurality of electric motors the combination with the groups of coils comprising the field-windings, of a main-controller cylinder having contacts for regulating the speed of the motors, stationary contacts with which the main-controller-cylinder contacts cooperate, a cylinder provided with contacts for regulating the field changes of the motor-windings and with contacts for reversing the direction of rotation of the motors, stationary contacts with which the contacts of the field-change and reversing cylinder cooperate, means operative from the main-controller cylinder for turning said field-change and reversing cylinder through small angles to change its field-contacts when the direction of movement of the main-controller cylinder is changed at any particular speed-notch, means

for turning said field-change and reversing cylinder through large angles independently of the main-controller cylinder, means for automatically preventing the movement of the main-controller cylinder during the large angular movements of the field-change and reversing cylinder, means for automatically preventing the movement of the field-change and reversing cylinder from the exterior of the controller until the main-controller cylinder has been turned to the "off" position, and means for automatically causing the field-change and reversing cylinder to assume the position in which its contacts cause the series condition of the motors when the main-controller cylinder assumes the "off" position substantially as and for the purposes specified. 55

9. In a plurality of electric motors, the combination with the groups of coils comprising the field-windings, of a main-controller cylinder having contacts for regulating the speed of the motors, a cylinder provided with two sets of contacts cooperating with two rows of stationary contacts, means for moving said cylinder through comparatively small angles to change the character of the motor field-windings from series to compound and vice versa and means for moving said cylinder through comparatively large angles to change the direction of rotation of the motors, substantially as described. 65

In testimony whereof I have hereunto set my hand, in presence of two subscribing witnesses, this 15th day of January, 1904. 70

JOHAN GUSTAF VIKTOR LANG.

Witnesses:

T. SELLY WARDLE,
WALTER J. SKERTEN.