



INTERNATIONAL APPLICATION PUBLISHED UNDER THE PATENT COOPERATION TREATY (PCT)

<p>(51) International Patent Classification ⁶ : A61B 1/00</p>	<p>A1</p>	<p>(11) International Publication Number: WO 96/39914</p> <p>(43) International Publication Date: 19 December 1996 (19.12.96)</p>
<p>(21) International Application Number: PCT/US96/08077</p> <p>(22) International Filing Date: 30 May 1996 (30.05.96)</p> <p>(30) Priority Data: 08/485,219 7 June 1995 (07.06.95) US</p> <p>(71) Applicant: ARTHROCARE CORPORATION [US/US]; 595 North Pastoria Avenue, Sunnyvale, CA 94086 (US).</p> <p>(72) Inventors: EGGERS, Philip, E.; 5366 Reserve Drive, Dublin, OH 43017 (US). THAPLIYAL, Hira, V.; 1192 Volti Lane, Los Altos, CA 94024 (US).</p> <p>(74) Agents: RAFFLE, John, T. et al.; Townsend and Townsend and Crew L.L.P., 8th floor, Two Embarcadero Center, San Francisco, CA 94111-3834 (US).</p>		<p>(81) Designated States: AU, CA, JP, NZ, European patent (AT, BE, CH, DE, DK, ES, FI, FR, GB, GR, IE, IT, LU, MC, NL, PT, SE).</p> <p>Published <i>With international search report.</i></p>
<p>(54) Title: SYSTEM AND METHOD FOR ELECTROSURGICAL CUTTING AND ABLATION</p>		
<p>(57) Abstract</p> <p>An electrosurgical probe (10) comprises a shaft (13) having an electrode array (12) at its distal end and a connector (19) at its proximal end for coupling the electrode array to a high frequency power supply (28). The shaft includes a return electrode (55, 56) recessed from its distal end and enclosed within an insulating jacket (18). The return electrode defines an inner passage (83) electrically connected to both the return electrode and the electrode array for passage of an electrically conducting liquid (50). By applying high frequency voltage to the electrode array and the return electrode, the electrically conducting liquid generates a current flow path between the target site and the return electrode so that target tissue may be cut or ablated. The probe is particularly useful in dry environments, such as the mouth or abdominal cavity, because the electrically conducting liquid provides the necessary return current path between the return electrode and the target site.</p>		

FOR THE PURPOSES OF INFORMATION ONLY

Codes used to identify States party to the PCT on the front pages of pamphlets publishing international applications under the PCT.

AM	Armenia	GB	United Kingdom	MW	Malawi
AT	Austria	GE	Georgia	MX	Mexico
AU	Australia	GN	Guinea	NE	Niger
BB	Barbados	GR	Greece	NL	Netherlands
BE	Belgium	HU	Hungary	NO	Norway
BF	Burkina Faso	IE	Ireland	NZ	New Zealand
BG	Bulgaria	IT	Italy	PL	Poland
BJ	Benin	JP	Japan	PT	Portugal
BR	Brazil	KE	Kenya	RO	Romania
BY	Belarus	KG	Kyrgystan	RU	Russian Federation
CA	Canada	KP	Democratic People's Republic of Korea	SD	Sudan
CF	Central African Republic	KR	Republic of Korea	SE	Sweden
CG	Congo	KZ	Kazakhstan	SG	Singapore
CH	Switzerland	LI	Liechtenstein	SI	Slovenia
CI	Côte d'Ivoire	LK	Sri Lanka	SK	Slovakia
CM	Cameroon	LR	Liberia	SN	Senegal
CN	China	LT	Lithuania	SZ	Swaziland
CS	Czechoslovakia	LU	Luxembourg	TD	Chad
CZ	Czech Republic	LV	Latvia	TG	Togo
DE	Germany	MC	Monaco	TJ	Tajikistan
DK	Denmark	MD	Republic of Moldova	TT	Trinidad and Tobago
EE	Estonia	MG	Madagascar	UA	Ukraine
ES	Spain	ML	Mali	UG	Uganda
FI	Finland	MN	Mongolia	US	United States of America
FR	France	MR	Mauritania	UZ	Uzbekistan
GA	Gabon			VN	Viet Nam

SYSTEM AND METHOD FOR ELECTROSURGICAL CUTTING AND ABLATION

5

BACKGROUND OF THE INVENTION

10

15

1. Field of the Invention

20 The present invention relates generally to the field of electrosurgery and, more particularly, to surgical devices and methods which employ high frequency voltage to cut and ablate tissue.

25 The field of electrosurgery includes a number of loosely related surgical techniques which have in common the application of electrical energy to modify the structure or integrity of patient tissue. Electrosurgical procedures usually operate through the application of very high frequency currents to cut or ablate tissue structures, where the operation can be monopolar or bipolar. Monopolar techniques 30 rely on external grounding of the patient, where the surgical device defines only a single electrode pole. Bipolar devices comprise both electrodes for the application of current between their surfaces.

35 Electrosurgical procedures and techniques are particularly advantageous since they generally reduce patient bleeding and trauma associated with cutting operations. Additionally, electrosurgical ablation procedures, where tissue surfaces and volume may be reshaped, cannot be

duplicated through other treatment modalities.

Current electrosurgical devices and procedures, however, suffer from a number of disadvantages. For example, monopolar devices generally direct electric current along a defined path from the exposed or active electrode through the patient's body to the return electrode, which is externally attached to a suitable location on the patient. This creates the potential danger that the electric current will flow through undefined paths in the patient's body, thereby increasing the risk of unwanted electrical stimulation to portions of the patient's body. In addition, since the defined path through the patient's body has a relatively high impedance (because of the large distance or resistivity of the patient's body), large voltage differences must typically be applied between the return and active electrodes in order to generate a current suitable for ablation or cutting of the target tissue. This current, however, may inadvertently flow along body paths having less impedance than the defined electrical path, which will substantially increase the current flowing through these paths, possibly causing damage to or destroying surrounding tissue.

Bipolar electrosurgical devices have an inherent advantage over monopolar devices because the return current path does not flow through the patient. In bipolar electrosurgical devices, both the active and return electrode are typically exposed so that they may both contact tissue, thereby providing a return current path from the active to the return electrode through the tissue. One drawback with this configuration, however, is that the return electrode may cause tissue desiccation or destruction at its contact point with the patient's tissue. In addition, the active and return electrodes are typically positioned close together to ensure that the return current flows directly from the active to the return electrode. The close proximity of these electrodes generates the danger that the current will short across the electrodes, possibly impairing the electrical control system and/or damaging or destroying surrounding tissue.

The use of electrosurgical procedures (both

monopolar and bipolar) in electrically conductive environments can be further problematic. For example, many arthroscopic procedures require flushing of the region to be treated with isotonic saline (also referred to as normal saline), both to
5 maintain an isotonic environment and to keep the field of viewing clear. The presence of saline, which is a highly conductive electrolyte, can also cause shorting of the electrosurgical electrode in both monopolar and bipolar modes. Such shorting causes unnecessary heating in the treatment
10 environment and can further cause non-specific tissue destruction.

In response to the various problems associated with electrosurgical procedures in electrically conductive environments, new methods and devices have been developed by
15 the applicant. These methods and devices provide selective power delivery to the target tissue while minimizing power delivery to the surrounding electrically conductive irrigant. These methods are particularly useful in isotonic saline filled body cavities, such as arthroscopic, urologic or
20 gynecologic cavities. The irrigant flooded body cavity provides good visibility, facilitates the removal of bubbles or other debris, minimizes the possibility of air embolism and protects certain tissue from dehydration. Such methods and devices are more fully described in previously filed, commonly
25 assigned applications Serial Nos. 08/059,681, 07/958,977 and 07/817,575, the full disclosures of which have been incorporated by reference.

Many surgical procedures, such as oral, laparoscopic and open surgical procedures, are not performed with the
30 target tissue submerged under an irrigant. In laparoscopic procedures, such as the resection of the gall bladder from the liver, for example, the abdominal cavity is pressurized with carbon dioxide (pneumoperitoneum) to provide working space for the instruments and to improve the surgeon's visibility of the
35 surgical site. Other procedures, such as the ablation of muscle or gingiva tissue in the mouth or the ablation and necrosis of diseased tissue, are also typically performed in a "dry" environment or field (i.e., not submerged under an

electrically conducting irrigant).

For these and other reasons, improved systems and methods are desired for the electrosurgical ablation and cutting of tissue. These systems and methods should be
5 capable of providing a direct return current path from the active electrode, through the target site, to the return electrode to minimize the dangers of electrical current flowing through undefined paths in the patient's body. The system should also be configured to minimize contact between
10 the return electrode and surrounding tissue and to avoid current shorting between the active and return electrodes. Preferably, the system will be configured to apply high frequency voltage for the cutting and ablation of tissue in relatively dry environments, such as those encountered in
15 oral, laparoscopic and open surgical procedures.

2. Description of the Background Art

Devices incorporating radio frequency electrodes for use in electrosurgical and electrocautery techniques are
20 described in Rand et al. (1985) *J. Arthro. Surg.* 1:242-246 and U.S. Patent Nos. 5,281,216; 4,943,290; 4,936,301; 4,593,691; 4,228,800; and 4,202,337. U.S. Patent Nos. 4,943,290 and 4,036,301 describe methods for injecting non-conducting liquid over the tip of a monopolar electrosurgical electrode to
25 electrically isolate the electrode, while energized, from a surrounding electrically conducting irrigant. U.S. Patent Nos. 5,195,959 and 4,674,499 describe monopolar and bipolar electrosurgical devices, respectively, that include a conduit for irrigating the surgical site.

30

SUMMARY OF THE INVENTION

The present invention provides an apparatus and method for selectively applying electrical energy to structures within a patient's body. The apparatus and method
35 allow the surgical team to perform electrosurgical interventions, such as ablation and cutting of body structures, without requiring the tissue to be submerged in an electrically conducting irrigant, such as isotonic saline.

The apparatus and method of the present invention are particularly useful for treating and shaping gingiva, for tissue dissection, e.g. separation of gall bladder from the liver, and ablation and necrosis of diseased tissue, such as tumors.

The method of the present invention comprises positioning an electrosurgical probe adjacent the target tissue so that at least one active electrode is brought into at least partial contact or close proximity with the target site. Electrically conducting liquid, such as isotonic saline, is directed through a fluid path past a return electrode and to the target site to generate a current flow path between the target site and the return electrode. High frequency voltage is then applied between the active and return electrode through the current flow path created by the electrically conducting liquid in either a bipolar or monopolar manner. The probe may then be translated, reciprocated or otherwise manipulated to cut the tissue or effect the desired depth of ablation.

The above described method is particularly effective in a dry environment (i.e., the tissue is not submerged in fluid), such as open, laparoscopic or oral surgery, because the electrically conducting liquid provides a suitable current flow path from the target site to the return electrode. The active electrode is preferably disposed at the distal end of the probe and the return electrode is spaced from the active electrode and enclosed within an insulating sheath. This minimizes exposure of the return electrode to surrounding tissue and minimizes possible shorting of the current between the active and return electrodes. In oral procedures, the probe may be introduced directly into the cavity of the open mouth so that the active electrode is positioned against gingival or mucosal tissue. In laparoscopic procedures, the probe will typically be passed through a conventional trocar cannula while viewing of the operative site is provided through the use of a laparoscope disposed in a separate cannula.

The apparatus according to the present invention

comprises an electrosurgical probe having a shaft with a proximal end, a distal end, and at least one active electrode at or near the distal end. A connector is provided at or near the proximal end of the shaft for electrically coupling the active electrode to a high frequency voltage source. A return electrode coupled to the voltage source is spaced a sufficient distance from the active electrode to substantially avoid or minimize current shorting therebetween and to shield the return electrode from tissue. The return electrode may be provided integral with the shaft of the probe or it may be separate from the shaft (e.g., on a liquid supply instrument). In both cases, the return electrode defines an inner passage for flow of electrically conducting liquid therethrough. The liquid is directed through the return electrode and over the active electrode to thereby provide a return current flow path between the tissue target site and the return electrode.

In a preferred aspect of the invention, the active electrode comprises an electrode array having a plurality of electrically isolated electrode terminals disposed over a contact surface, which may be a planar or non-planar surface and which may be located at the distal tip or over a lateral surface of the shaft, or over both the tip and lateral surface(s). The electrode array will include at least two and preferably more electrode terminals, and may further comprise a temperature sensor. In a preferred aspect, each electrode terminal will be connected to the proximal connector by an electrically isolated conductor disposed within the shaft. The conductors permit independent electrical coupling of the electrode terminals to a high frequency power supply and control system with optional temperature monitor for operation of the probe. The control system preferably incorporate active and/or passive current limiting structures, which are designed to limit current flow when the associated electrode terminal is in contact with a low resistance return path back to the return electrode.

The use of such electrode arrays in electrosurgical procedures is particularly advantageous as it has been found to limit the depth of tissue necrosis without substantially

reducing power delivery and ablation rates. The voltage applied to each electrode terminal causes electrical energy to be imparted to any body structure which is contacted by, or comes into close proximity with, the electrode terminal, where
5 a current flow through all low electrical impedance paths is preferably but not necessarily limited. It will be appreciated that such low impedance paths generally occur when an electrode terminal does not contact or come into close
10 proximity with the body structure, but rather is in contact with a low impedance environment, such as the saline, or other electrolyte being introduced past the return electrode. The presence of an electrolyte provides a relatively low impedance path back to the common or return electrode.

The apparatus and method of the present invention
15 provide a number of advantages, particularly in respect to the ablation or cutting of tissue. The ability to control current flow through individual electrode terminals minimizes power dissipation into the surrounding medium. Limited power
20 dissipation, in turn, permits the use of electrolytic irrigants, such as isotonic saline, to create a current flow path between the active electrode terminals and the return electrode. The isotonic saline may also be used to
25 simultaneously irrigate the surgical site, which provides a number of well know physiological advantages. In addition, the ability to operate in a bipolar or quasi-bipolar mode reduces the risk of unwanted electrical stimulation from
return current flowing through the patient's body, which can cause muscle spasms and can limit the depth of tissue necrosis during ablative resection.

30 A further understanding of the nature and advantages of the invention will become apparent by reference to the remaining portions of the specification and drawings.

BRIEF DESCRIPTION OF THE DRAWINGS

35 Fig. 1 is a perspective view of the electrosurgical system including an electrosurgical probe, an electrically conducting liquid supply and an electrosurgical power supply constructed in accordance with the principles of the present

invention;

Fig. 2A is an enlarged, cross-sectional view of the distal tip of the electrosurgical probe of Fig. 1 illustrating an electrode arrangement suitable for rapid cutting and
5 ablation of tissue structures;

Fig. 2B is an enlarged end view of the distal tip of the electrosurgical probe of Fig. 1;

Fig. 2C is a cross-sectional view of the proximal end of the electrosurgical probe, illustrating an arrangement
10 for coupling the probe to the electrically conducting liquid supply of Fig. 1;

Fig. 3 is a detailed cross-sectional view of an alternative embodiment of the electrosurgical probe of Fig. 1;

Fig. 4 is an end view of the distal end of the
15 electrosurgical probe of Fig. 3;

Fig. 5 is an end view of an another embodiment of the electrosurgical probe of Fig. 1;

Fig. 6 is a partial cross-sectional side view of a further embodiment of the electrosurgical probe with the
20 electrode array disposed transversely to the axis of the probe;

Fig. 7 is a partial front cross-sectional view of an electrosurgical probe and an electrically conductive liquid supply shaft illustrating use of the probe and the shaft in
25 ablating target tissue;

Fig. 8 is an enlarged, cross-sectional view of the distal tip of yet another embodiment of the electrosurgical probe of Fig. 1;

Fig. 9 is a detailed end view of the probe of Fig.
30 8;

Fig. 10 is a side view of an electrosurgical probe having a shaft with an angled distal portion;

Fig. 11 is a side view of an electrosurgical probe having a shaft with a perpendicular distal portion;

Fig. 12 is a schematic view of an electrosurgical probe having two screwdriver-shaped electrodes extending from
35 the distal end;

Fig. 13 is an end view of the probe of Fig. 12; and

Fig. 14 illustrates use of the probe of Fig. 12 for the rapid cutting of tissue.

DESCRIPTION OF THE PREFERRED EMBODIMENTS

5 The present invention provides an apparatus and method for selectively applying electrical energy to a target location within a patient's body, such as solid tissue or the like, particularly including gingival tissues and mucosal tissues located in the mouth. In addition, tissues which may
10 be treated by the system and method of the present invention include tumors, abnormal tissues, and the like. For convenience, the remaining disclosure will be directed specifically to the cutting, shaping or ablation of gingival or mucosal tissue in oral surgical procedures, but it will be
15 appreciated that the system and method can be applied equally well to procedures involving other tissues of the body, as well as to other procedures including open surgery, laparoscopic surgery, thoracoscopic surgery, and other endoscopic surgical procedures.

20 The present invention uses an electrode array including a plurality of independently current-limited and/or power-controlled electrode terminals distributed over a distal contact surface of a probe to apply electrical energy selectively to the target tissue while limiting the unwanted
25 application of electrical energy to the surrounding tissue and environment resulting from power dissipation into surrounding electrically conductive liquids, such as blood, normal saline, and the like.

30 The electrosurgical probe will comprise a shaft having a proximal end and a distal end which supports an electrode array near its distal end. The shaft may assume a wide variety of configurations, with the primary purpose being to mechanically support the electrode array and permit the treating physician to manipulate the array from a proximal end
35 of the shaft. Usually, the shaft will be a narrow-diameter rod or tube, more usually having dimensions which permit it to be introduced into a body cavity, such as the mouth or the abdominal cavity, through an associated trocar or cannula in a

minimally invasive procedure, such as arthroscopic, laparoscopic, thoracoscopic, and other endoscopic procedures. Thus, the shaft will typically have a length of at least 5cm for oral procedures and at least 10 cm, more typically being
5 20 cm, or longer for endoscopic procedures. The shaft will typically have a diameter of at least 1 mm and frequently in the range from 1 to 10 mm. The shaft may be rigid or flexible, with flexible shafts optionally being combined with a generally rigid external tube for mechanical support.
10 Flexible shafts may be combined with pull wires, shape memory actuators, and other known mechanisms for effecting selective deflection of the distal end of the shaft to facilitate positioning of the electrode array. The shaft will usually include a plurality of wires or other conductive elements
15 running axially therethrough to permit connection of the electrode array to a connector at the proximal end of the shaft. Specific shaft designs will be described in detail in connection with the figures hereinafter.

The circumscribed area of the electrode array is in
20 the range from 0.25 mm² to 75 mm², preferably from 0.5 mm² to 40 mm², and will usually include at least two isolated electrode terminals, more usually at least four electrode terminals, preferably at least six electrode terminals, and often 50 or more electrode terminals, disposed over the distal
25 contact surfaces on the shaft. By bringing the electrode array(s) on the contact surface(s) against or in close proximity with the target tissue and applying high frequency voltage between the array(s) and an additional common or return electrode in direct or indirect contact with the
30 patient's body, the target tissue is selectively ablated or cut, permitting selective removal of portions of the target tissue while desirably minimizing the depth of necrosis to surrounding tissue. In particular, this invention provides a method and apparatus for effectively ablating and cutting
35 tissue which may be located in close proximity to other critical organs, vessels or structures (e.g., teeth, bone) by simultaneously (1) causing electrically conducting liquid to flow between the common and active electrodes, (2) applying

electrical energy to the target tissue surrounding and immediately adjacent to the tip of the probe, (3) bringing the active electrode(s) in contact or close proximity with the target tissue using the probe itself, and (4) optionally
5 moving the electrode array axially and/or transversely over the tissue.

Each individual electrode terminal in the electrode array is electrically insulated from all other electrode terminals in the array within said probe and is connected to a
10 power source which is isolated from each of the other electrodes in the array or to circuitry which limits or interrupts current flow to the electrode when low resistivity material (e.g., blood or electrically conductive saline
irrigant) causes a lower impedance path between the common
15 electrode and the individual electrode terminal. The isolated power sources for each individual electrode may be separate power supply circuits having internal impedance characteristics which limit power to the associated electrode terminal when a low impedance return path is encountered, may
20 be a single power source which is connected to each of the electrodes through independently actuatable switches or may be provided by independent current limiting elements, such as inductors, capacitors, resistors and/or combinations thereof.

The tip region of the probe is thus composed of many
25 independent electrode terminals designed to deliver electrical energy in the vicinity of the tip. The selective application of electrical energy to of the target tissue is achieved by connecting each individual electrode terminal and the common electrode to a power source having independently controlled or
30 current limited channels. The common electrode may be a tubular member of conductive material proximal to the electrode array at the tip which also serves as a conduit for the supply of the electrically conducting liquid between the active and common electrodes. The application of high
35 frequency voltage between the common electrode and the electrode array results in the generation of high electric field intensities at the distal tips of the electrodes with conduction of high frequency current from each individual

electrode terminal to the said common electrode. The current flow from each individual electrode terminal to the common electrode is controlled by either active or passive means, or a combination thereof, to deliver electrical energy to the target tissue while minimizing energy delivery to surrounding (non-target) tissue and any conductive fluids which may be present (e.g., blood, electrolytic irrigants such as saline, and the like).

In a preferred aspect, this invention takes advantage of the differences in electrical resistivity between the target tissue (e.g., gingiva, muscle, fascia, tumor or other connective tissue) and the surrounding conductive liquid (e.g., isotonic saline irrigant). By way of example, for any selected level of applied voltage, if the electrical conduction path between the common electrode and one of the individual electrode terminals within the electrode array is isotonic saline irrigant liquid (having a relatively low electrical impedance), the current control means connected to the individual electrode will limit current flow so that the heating of intervening conductive liquid is minimized. On the other hand, if a portion of or all of the electrical conduction path between the common electrode and one of the individual electrode terminals within the electrode array is gingival tissue (having a relatively higher electrical impedance), the current control circuitry or switch connected to the individual electrode will allow current flow sufficient for the deposition of electrical energy and associated ablation or electrical breakdown of the target tissue in the immediate vicinity of the electrode surface.

The application of a high frequency voltage between the common or return electrode and the electrode array for appropriate time intervals effects ablation, cutting or reshaping of the target tissue. The tissue volume over which energy is dissipated (i.e., a high voltage gradient exists) may be precisely controlled, for example, by the use of a multiplicity of small electrodes whose effective diameters range from about 2 mm to 0.01 mm, preferably from about 1 mm to 0.05 mm, and more preferably from about 0.5 mm to 0.1 mm.

Electrode areas for both circular and non-circular terminals will have a contact area (per electrode) below 5 mm², preferably being in the range from 0.0001 mm² to 1 mm², and more preferably from 0.005 mm² to .5 mm². The use of small diameter electrode terminals increases the electric field intensity and reduces the extent or depth of tissue necrosis as a consequence of the divergence of current flux lines which emanate from the exposed surface of each electrode terminal. Energy deposition in tissue sufficient for irreversible damage (i.e., necrosis) has been found to be limited to a distance of about one-half to one electrode diameter. This is a particular advantage over prior electrosurgical probes employing single and/or larger electrodes where the depth of tissue necrosis may not be sufficiently limited.

In previous electrosurgical devices, increased power application and ablation rates have been achieved by increasing the electrode area. Surprisingly, with the present invention, it has been found that the total electrode area can be increased (to increase power delivery and ablation rate) without increasing the depth of necrosis by providing multiple small electrode terminals. Preferably, the terminals will be spaced-apart by a distance in the range from about one-half diameter to one diameter for optimum power delivery, as discussed below. The depth of necrosis may be further controlled by switching the applied voltage off and on to produce pulses of current, the pulses being of sufficient duration and associated energy density to effect ablation and/or cutting while being turned off for periods sufficiently long to allow for thermal relaxation between energy pulses. In this manner, the energy pulse duration and magnitude and the time interval between energy pulses are selected to achieve efficient rates of tissue ablation or cutting while allowing the temperature of the treated zone of tissue to "relax" or return to normal physiologic temperatures (usually to within 10°C of normal body temperature [37°C], preferably to within 5°C) before the onset of the next energy (current) pulse.

The rate of energy delivery to the target tissue is

controlled by the applied voltage level and duty cycle of the voltage pulse. The use of high frequency current minimizes induced stimulation of muscle tissue or nerve tissue in the vicinity of the body structure being treated. In addition,
5 high frequencies minimize the risk of interfering with the natural pacing of the heart in circumstances where the probe of the present invention is used near the heart.

The power applied to the common electrode and the electrode array will be at high or radio frequency, typically
10 between about 20 kHz and 20 MHz, usually being between about 30 kHz and 2 MHz, and preferably being between about 50 kHz and 400 kHz. The RMS (root mean square) voltage applied will usually be in the range from about 5 volts to 1000 volts, preferably being in the range from about 50 volts to 800
15 volts, and more preferably being in the range from about 10 volts to 500 volts. Usually, the current level will be selectively limited or controlled and the voltage applied will be independently adjustable, frequently in response to the resistance of tissues and/or fluids in the pathway between an
20 individual electrode and the common electrode. Also, the applied current level may be in response to a temperature control means which maintains the target tissue temperature with desired limits at the interface between the electrode arrays and the target tissue. The desired surface temperature
25 along a propagating surface just beyond the region of ablation will usually be in the range from about 40°C to 100°C, and more usually from about 50°C to 60°C. The tissue being ablated immediately adjacent the electrode array may reach even higher temperatures.

30 The preferred power source of the present invention delivers a high frequency current selectable to generate average power levels ranging from tens of milliwatts to tens of watts per electrode, depending on the target tissue being ablated, the rate of ablation desired or the maximum allowed
35 temperature selected for the probe tip. The power source allows the user to select the current level according to the specific requirements of a particular oral surgery, open surgery or other endoscopic surgery procedure.

The power source will be current limited or otherwise controlled so that undesired heating of electrically conductive fluids or other low electrical resistance media does not occur. In a presently preferred embodiment of the present invention, current limiting inductors are placed in series with each independent electrode terminal, where the inductance of the inductor is in the range of 20uH to 5000uH, depending on the electrical properties of the target tissue, the desired ablation rate and the operating frequency. Alternatively, capacitor-inductor (LC) circuit structures may be employed, as described previously in co-pending PCT application No. PCT/US94/05168, which has already been incorporated herein by reference. Additionally, current limiting resistors may be selected having a large positive temperature coefficient of resistance so that, as the current level begins to rise for any individual electrode in contact with a low resistance medium (e.g., saline irrigant), the resistance of the current limiting resistor increases significantly, thereby minimizing the power delivery from said electrode into the low resistance medium (e.g., saline irrigant).

As an alternative to such passive circuit structures, regulated current flow to each electrode terminal may be provided by a multi-channel power supply. A substantially constant current level for each individual electrode terminal within a range which will limit power delivery through a low resistance path, e.g., isotonic saline irrigant, would be selected by the user to achieve the desired rate of cutting or ablation. Such a multi-channel power supply thus provides a substantially constant current source with selectable current level in series with each electrode terminal, wherein all electrodes will operate at or below the same, user selectable maximum current level. Current flow to all electrode terminals could be periodically sensed and stopped if the temperature measured at the surface of the electrode array exceeds user selected limits. Particular control system designs for implementing this strategy are well within the skill of the art.

Yet another alternative involves the use of one or several power supplies which allow one or several electrodes to be simultaneously energized and which include active control means for limiting current levels below a preselected maximum level. In this arrangement, only one or several electrodes would be simultaneously energized for a brief period. Switching means would allow the next one or several electrodes to be energized for a brief period. By sequentially energizing one or several electrodes, the interaction between adjacent electrodes can be minimized (for the case of energizing several electrode positioned at the maximum possible spacing within the overall envelope of the electrode array) or eliminated (for the case of energizing only a single electrode at any one time). As before, a resistance measurement means may be employed for each electrode prior to the application of power wherein a (measured) low resistance (below some preselected level) will prevent that electrode from being energized during given cycle. By way of example, the sequential powering and control scheme of the present invention would function in a manner similar to an automobile distributor. In this example, an electrical contact rotates past terminals connected to each spark plug. In this example, each spark plug corresponds to the exposed surface of each of the electrodes. In addition, the present invention includes the means to measure the resistance of the medium in contact with each electrode and cause voltage to be applied only if the resistance exceeds a preselected level.

The electrode array is formed over a contact surface on the shaft of the electrosurgical probe. The common (return) electrode surface will be recessed relative to the distal end of the probe and may be recessed within the conduit provided for the introduction of electrically conducting liquid to the site of the target tissue and array of active electrodes. In the exemplary embodiment, the shaft will be cylindrical over most of its length, with the contact surface being formed at the distal end of the shaft. In the case of laparoscopic or endoscopic applications, the contact surface

may be recessed since it helps protect and shield the electrode terminals on the surface while they are being introduced, particularly while being introduced through the working channel of a trocar channel or a viewing scope.

5 The area of the contact surface can vary widely, and the contact surface can assume a variety of geometries, with particular areas in geometries being selected for specific applications. Electrode array contact surfaces can have areas in the range from 0.25 mm² to 50 mm², usually being from 1 mm²
10 to 20 mm². The geometries can be planar, concave, convex, hemispherical, conical, or virtually any other regular or irregular shape. Most commonly, the electrode arrays will be formed at the distal tip of the electrosurgical probe shaft, frequently being planar, disk-shaped, or hemispherical
15 surfaces for use in reshaping procedures or being linear arrays for use in cutting. Alternatively or additionally, the electrode arrays may be formed on lateral surfaces of the electrosurgical probe shaft (e.g., in the manner of a spatula), facilitating access to certain body structures in
20 electrosurgical procedures.

Referring to the drawings in detail, wherein like numerals indicate like elements, an electrosurgical system 11 is shown constructed according to the principles of the present invention. Electrosurgical system 11 generally
25 comprises an electrosurgical probe 10 connected to a power supply 28 for providing high frequency voltage to a target tissue 52 and a liquid source 21 for supplying electrically conducting fluid 50 to probe 10.

In an exemplary embodiment as shown in Fig. 1, electrosurgical probe 10 includes an elongated shaft 13 which
30 may be flexible or rigid, with flexible shafts optionally including support cannulas or other structures (not shown). Probe 10 includes a connector 19 at its proximal end and an array 12 of electrode terminals 58 disposed on the distal tip
35 of shaft 13. A connecting cable 34 has a handle 22 with a connector 20 which can be removably connected to connector 19 of probe 10. The proximal portion of cable 34 has a connector 26 to couple probe 10 to power supply 28. The electrode

terminals 58 are electrically isolated from each other and each of the terminals 58 is connected to an active or passive control network within power supply 28 by means of a plurality of individually insulated conductors 42 (see Fig. 2C). Power supply 28 has a selection means 30 to change the applied voltage level. Power supply 28 also includes means for energizing the electrodes 58 of probe 10 through the depression of a pedal 39 in a foot pedal 37 positioned close to the user. The foot pedal 37 may also include a second pedal (not shown) for remotely adjusting the energy level applied to electrodes 58. The specific design of a power supply which may be used with the electrosurgical probe of the present invention is described in parent application PCT US 94/051168, the full disclosure of which has previously been incorporated herein by reference.

Referring to Figs. 2A and 2B, the electrically isolated electrode terminals 58 are spaced-apart over an electrode array surface 82. The electrode array surface 82 and individual electrode terminals 58 will usually have dimensions within the ranges set forth above. In the preferred embodiment, the electrode array surface 82 has a circular cross-sectional shape with a diameter D (Fig. 2B) in the range from 1 mm to 10 mm. Electrode array surface 82 may also have an oval shape, having a length L in the range of 1 mm to 20 mm and a width W in the range from 0.5 mm to 7 mm, as shown in Fig. 5. The individual electrode terminals 58 will protrude over the electrode array surface 82 by a distance (H) from 0 mm to 2 mm, preferably from 0 mm to 1 mm (see Fig. 3). As described above, electrode terminals which are flush with the surface, or protrude by a minimum distance, will provide less aggressive ablation and are particularly suitable for smoothing of treated tissue surfaces and providing hemostasis to inhibit or prevent bleeding of treated surfaces.

The electrode terminals 58 are preferably composed of a refractory, electrically conductive metal or alloy, such as platinum, platinum alloys, titanium, titanium alloys and the like. Platinum is the preferred choice for electrode terminal material since it is biocompatible, has a low erosion

rate, and can be readily fabricated and attached to conductors 42 within the shaft 13 of electrosurgical probe 10. As shown in Fig. 2B, the electrode terminals 58 are anchored in a support matrix 48 of suitable insulating material (e.g., ceramic or glass material, such as alumina, zirconia and the like) which could be formed at the time of manufacture in a flat, hemispherical or other shape according to the requirements of a particular procedure. The preferred support matrix material is alumina, available from Kyocera Industrial Ceramics Corporation, Elk Grove, Illinois, because of its high thermal conductivity, good electrically insulative properties, high flexural modulus, resistance to carbon tracking, biocompatibility, and high melting point.

As shown in Fig. 2A, the support matrix 48 is adhesively joined to a tubular support member 78 that extends most or all of the distance between matrix 48 and the proximal end of probe 10. Tubular member 78 preferably comprises an electrically insulating material, such as an epoxy or silicone-based material. In a preferred construction technique, electrode terminals 58 extend through pre-formed openings in the support matrix 48 so that they protrude above electrode array surface 82 by the desired distance H (Fig. 3). The electrodes are then bonded to the distal surface 82 of support matrix 48, typically by an inorganic sealing material 80. Sealing material 80 is selected to provide effective electrical insulation, and good adhesion to both the alumina matrix 48 and the platinum or titanium electrode terminals. Sealing material 80 additionally should have a compatible thermal expansion coefficient and a melting point well below that of platinum or titanium and alumina or zirconia, typically being a glass or glass ceramic.

In the embodiment shown in Figs. 2A and 2B, probe 10 includes a return electrode 56 for completing the current path between electrode terminals 58 and power supply 28. Return electrode 56 is preferably an annular member positioned around the exterior of shaft 13 of probe 10. Return electrode 56 may fully or partially circumscribe tubular support member 78 to form an annular gap 54 therebetween for flow of electrically

conducting liquid 50 therethrough, as discussed below. Gap 54 preferably has a width in the range of 0.25 mm to 4 mm.

Return electrode 56 extends from the proximal end of probe 10, where it is suitably connected to power supply 28 via
5 connectors 19, 20, to a point slightly proximal of electrode array surface 82, typically about 1mm to 10 mm.

Return electrode 56 is disposed within an electrically insulative jacket 18, which is typically formed as one or more electrically insulative sheaths or coatings,
10 such as polytetrafluoroethylene, polyamide, and the like. The provision of the electrically insulative jacket 18 over return electrode 56 prevents direct electrical contact between return electrode 56 and any adjacent body structure. Such direct electrical contact between a body structure (e.g., tendon) and
15 an exposed common electrode member 56 could result in unwanted heating and necrosis of the structure at the point of contact causing necrosis.

Return electrode 56 is preferably formed from an electrically conductive material, usually metal, which is
20 selected from the group consisting of stainless steel, platinum or its alloys, titanium or its alloys, molybdenum or its alloys, and nickel or its alloys. The return electrode 56 may be composed of the same metal or alloy which forms the electrode terminals 58 to minimize any potential for corrosion
25 or the generation of electrochemical potentials due to the presence of dissimilar metals contained within an electrically conductive fluid 50, such as isotonic saline (discussed in greater detail below).

As shown in Fig. 2A, return electrode 56 is not
30 directly connected to electrode terminals 58. To complete this current path so that terminals 58 are electrically connected to return electrode 56 via target tissue 52, electrically conducting liquid 50 (e.g., isotonic saline) is caused to flow along liquid paths 83. Liquid paths 83 are
35 formed by annular gap 54 between outer return electrode 56 and tubular support member 78 and an inner lumen 57 within an inner tubular member 59. The electrically conducting liquid 50 flowing through fluid paths 83 provides a pathway for

electrical current flow between target tissue 52 and return electrode 56, as illustrated by the current flux lines 60 in Fig. 2A. When a voltage difference is applied between electrode array 12 and return electrode 56, high electric field intensities will be generated at the distal tips of terminals 58 with current flow from array 12 through the target tissue to the return electrode, the high electric field intensities causing ablation of tissue 52 in zone 88.

Figs. 2C, 3 and 4 illustrate an alternative embodiment of electrosurgical probe 10 which has a return electrode 55 positioned within tubular member 78. Return electrode 55 is preferably a tubular member defining an inner lumen 57 for allowing electrically conducting liquid 50 (e.g., isotonic saline) to flow therethrough in electrical contact with return electrode 55. In this embodiment, a voltage difference is applied between electrode terminals 58 and return electrode 55 resulting in electrical current flow through the electrically conducting liquid 50 as shown by current flux lines 60 (Fig. 3). As a result of the applied voltage difference and concomitant high electric field intensities at the tips of electrode terminals 58, tissue 52 becomes ablated or transected in zone 88.

Fig. 2C illustrates the proximal or connector end 70 of probe 10 in the embodiment of Figs. 3 and 4. Connector 19 comprises a plurality of individual connector pins 74 positioned within a housing 72 at the proximal end 70 of probe 10. Electrode terminals 58 and the attached insulating conductors 42 extend proximally to connector pins 74 in connector housing 72. Return electrode 55 extends into housing 72, where it bends radially outward to exit probe 10. As shown in Figs. 1 and 2C, a liquid supply tube 15 removably couples liquid source 21, (e.g., a bag of fluid elevated above the surgical site or having a pumping device), with return electrode 55. Preferably, an insulating jacket 14 covers the exposed portions of electrode 55. One of the connector pins 76 is electrically connected to return electrode 55 to couple electrode 55 to power supply 28 via cable 34. A manual control valve 17 may also be provided between the proximal end

of electrode 55 and supply tube 15 to allow the surgical team to regulate the flow of electrically conducting liquid 50.

Fig. 6 illustrates another embodiment of probe 10 where the distal portion of shaft 13 is bent so that electrode terminals extend transversely to the shaft. Preferably, the distal portion of shaft 13 is perpendicular to the rest of the shaft so that electrode array surface 82 is generally parallel to the shaft axis, as shown in Fig. 6. In this embodiment, return electrode 55 is mounted to the outer surface of shaft 13 and is covered with an electrically insulating jacket 18. The electrically conducting fluid 50 flows along flow path 83 through return electrode 55 and exits the distal end of electrode 55 at a point proximal of electrode surface 82. The fluid is directed exterior of shaft to electrode surface 82 to create a return current path from electrode terminals 58, through target tissue 52, to return electrode 55, as shown by current flux lines 60.

Fig. 7 illustrates another embodiment of the invention where electrosurgical system 11 further includes a liquid supply instrument 64 for supplying electrically conducting fluid 50 between electrode terminals 58 and return electrode 55. Liquid supply instrument 64 comprises an inner tubular member or return electrode 55 surrounded by an electrically insulating jacket 18. Return electrode 55 defines an inner passage 83 for flow of fluid 50. As shown in Fig. 7, the distal portion of instrument 64 is preferably bent so that liquid 50 is discharged at an angle with respect to instrument 64. This allows the surgical team to position liquid supply instrument 64 adjacent electrode surface 82 with the proximal portion of supply instrument 64 oriented at a similar angle to probe 10.

Figs. 8 and 9 illustrate another embodiment of probe 10 where the return electrode is an outer tubular member 56 that circumscribes support member 78 and conductors 42. Insulating jacket 18 surrounds tubular member 56 and is spaced from member 56 by a plurality of longitudinal ribs 96 to define an annular gap 54 therebetween (Fig. 9). Annular gap preferably has a width in the range of .25 mm to 4 mm. Ribs

96 can be formed on either the jacket 18 or member 56. The distal end of return electrode 56 is a distance L_1 from electrode surface 82. Distance L_1 is preferably about .5 to 10 mm and more preferably about 1 to 10 mm.

5 As shown in Fig. 8, electrically conducting liquid 50 flows through annular gap 54 (in electrical communication with the return electrode) and is discharged through the distal end of gap 54. The liquid 50 is then directed around support member 78 to electrode terminals 58 to provide the
10 current pathway between the electrode terminals and return electrode 56. Since return electrode 56 is proximally recessed with respect to electrode surface 82, contact between the return electrode 56 and surrounding tissue is minimized. In addition, the distance L_1 between the active electrode
15 terminals 58 and the return electrode 56 reduces the risk of current shorting therebetween.

The present invention is not limited to an electrode array disposed on a relatively planar surface at the distal tip of probe 10, as described above. Referring to Figs. 12-
20 14, an alternative probe 10 includes a pair of electrodes 58a, 58b mounted to the distal end of shaft 13. Electrodes 58a, 58b are electrically connected to power supply as described above and preferably have tips 100a, 100b with a screwdriver shape. The screwdriver shape provides a greater amount of
25 "edges" to electrodes 58a, 58b, to increase the electric field intensity and current density at the edges and thereby improve the cutting ability as well as the ability to limit bleeding from the incised tissue (i.e., hemostasis).

As shown in Fig. 12, current flows between electrode
30 tips 100a and 100b as indicated by current flux lines 60 to heat the target tissue 52. The surgical team then moves probe 10 transversely across tissue 52 to effect an incision 102 in tissue 52, as shown in Fig. 14.

Other modifications and variations can be made to
35 disclose embodiments without departing from the subject invention as defined in the following claims. For example, shaft 13 of probe 10 may have a variety of configurations other than the generally linear shape shown in Figs. 1-8. For

example, shaft 13 may have a distal portion that is angled, in the range of 10° to 30° (Fig. 10) or 90° (Figs. 11 and 6), to improve access to the operative site of the tissue 52 being ablated or cut (see Fig. 10). A shaft having a 90° bend angle
5 may be particular useful for accessing gingiva located in the back portion of the patient's mouth and a shaft having a 10° to 30° bend angle may be useful for accessing gingiva near or in the front of the patient's mouth.

WHAT IS CLAIMED IS:

- 1 1. A method for applying electrical energy to a
2 target site on a structure within a patient's body, the method
3 comprising:
4 positioning an electrosurgical probe adjacent to the
5 body structure so that an active electrode is brought into at
6 least partial contact or close proximity with the target site;
7 directing an electrically conducting liquid along a
8 fluid path past a return electrode and to the target site to
9 generate a current flow path between the target site and the
10 return electrode; and
11 applying high frequency voltage to the active
12 electrode and the return electrode such that an electrical
13 current flows from the active electrode, through the body
14 structure in the region of the target site, and to the return
15 electrode through the current flow path.
- 1 2. The method of claim 1 further comprising
2 generating a high electric field intensity at a distal portion
3 of the active electrode.
- 1 3. The method of claim 1 wherein the electrically
2 conductive liquid comprises isotonic saline.
- 1 4. The method of claim 1 wherein the probe is
2 introduced into a substantially dry body cavity so that the
3 target site is substantially electrically isolated from the
4 return electrode prior to the directing step.
- 1 5. The method of claim 4 further including
2 pressurizing the body cavity with a gas.
- 1 6. The method of claim 5 wherein the body cavity
2 is the patient's abdomen.
- 1 7. The method of claim 4 wherein the body cavity
2 is the patient's mouth.

1 8. The method of claim 1 wherein the directing
2 step includes supplying the electrically conductive liquid to
3 a proximal end of an axial lumen defined by the return
4 electrode within the probe and directing the liquid through a
5 distal end of the axial lumen to the active electrode.

1 9. The method of claim 1 further including
2 positioning a distal end of a liquid supply shaft adjacent the
3 active electrode, the directing step including directing the
4 electrically conducting liquid through an inner lumen in the
5 liquid supply shaft that is electrically connected to the
6 return electrode and discharging the liquid through an open
7 distal end of the supply shaft towards the active electrode.

1 10. A method for applying electrical energy to a
2 target site on a structure within a patient's body, the method
3 comprising:

4 positioning an electrosurgical probe adjacent to the
5 body structure so that an electrode array including a
6 plurality of isolated electrode terminals is brought into at
7 least partial contact or close proximity with the target site;
8 directing an electrically conducting liquid along a
9 fluid path past a return electrode and to the target site to
10 generate a current flow path between the target site and the
11 return electrode; and

12 applying high frequency voltage to the electrode
13 array and the return electrode such that an electrical current
14 flows between from electrical array, through the body
15 structure in the region of the target tissue, to the return
16 electrode through the current flow path.

1 11. The method of claim 10 further comprising
2 generating a high electric field intensity at a distal portion
3 of the electrode array.

1 12. The method of claim 10 including independently
2 controlling current flow from at least two of the electrode
3 terminals based on impedance between the electrode terminal
4 and the return electrode.

1 13. The method of claim 10 wherein the return
2 electrode is an inner tubular member defining an axial lumen
3 electrically connected to the inner tubular member, the
4 directing step including directing electrically conductive
5 liquid through the inner lumen to the distal end of the shaft
6 over the active electrode.

1 14. The method of claim 10 wherein the return
2 electrode is an outer tubular member, the shaft including an
3 insulating member defining an axial passage between the
4 insulating member and the outer tubular member, the directing
5 step including directing the electrically conductive liquid
6 through the inner lumen to the distal end of the shaft over
7 the active electrode.

1 15. The method of claim 10 further including
2 controlling flow of the electrically conductive liquid through
3 the fluid path with a control valve exterior to the probe.

1 16. The method of claim 10 further including
2 applying lateral pressure against the body structure with the
3 electrode array.

1 17. A method as in claim 10, further including
2 moving the electrode array transversely across the body
3 structure.

1 18. An electrosurgical probe for applying
2 electrical energy to a target site on a structure within a
3 patient's body comprising:
4 a shaft having a proximal end and a distal end;
5 an active electrode disposed near the distal end of
6 the shaft;

7 a connector disposed near the proximal end of the
8 shaft for electrically coupling the active electrode to a high
9 frequency voltage source;

10 a return electrode positioned near the active
11 electrode on the shaft and electrically coupled to the
12 connector; and

13 wherein the shaft defines a liquid path in
14 electrical contact with the return electrode, the liquid path
15 having an inlet for receiving electrically conductive liquid
16 to generate a current flow path from the active electrode,
17 through the body structure in the region of the target site,
18 and to the return electrode.

1 19. An electrosurgical probe as in claim 18 further
2 including an insulating sheath surrounding the return
3 electrode to minimize contact between the return electrode and
4 the target site.

1 20. An electrosurgical probe as in claim 18 wherein
2 the return electrode is an inner tubular member defining an
3 axial lumen electrically connected to the inner tubular
4 member, the axial lumen having an inlet for receiving the
5 electrically conductive liquid and an outlet in communication
6 with the active electrode.

1 21. An electrosurgical probe as in claim 18 wherein
2 the return electrode is an outer tubular member disposed
3 radially outward from the active electrode, the probe
4 including an insulating member defining an annular passage
5 between the insulating member and the outer tubular member,
6 the annular passage being electrically connected to the outer
7 tubular member, the annular passage having an inlet for
8 receiving the electrically conductive liquid and an outlet in
9 communication with the active electrode.

1 22. An electrosurgical probe as in claim 21 wherein
2 the insulating member is an electrically non-conductive sheath
3 circumscribing the outer tubular member.

1 23. An electrosurgical probe as in claim 21 wherein
2 the insulating member is disposed within the outer tubular
3 member.

1 24. An electrosurgical probe as in claim 18 wherein
2 the active electrode comprises an electrode array disposed
3 near the distal end of the shaft, the array including a
4 plurality of electrically isolated electrode terminals
5 disposed over a contact surface.

1 25. An electrosurgical probe as in claim 24 wherein
2 the return electrode has a distal end positioned proximal to
3 the electrode array.

1 26. An electrosurgical probe as in claim 25 wherein
2 the distal end of the return electrode is about 1 to 10 mm
3 from the electrode array.

1 27. An electrosurgical probe as in claim 18,
2 wherein the distal end of the shaft is oriented transversely
3 to the shaft axis, the return electrode comprising an outer
4 tubular member positioned on a perimeter of the shaft and
5 defining an inner lumen in electrical communication with the
6 outer tubular member for flow of the electrically conductive
7 liquid therethrough.

1 28. An electrosurgical system for use with a high
2 frequency power supply and an electrically conducting liquid
3 supply for applying electrical energy to a target site on a
4 structure within a patient's body, the system comprising:
5 an electrosurgical probe comprising a shaft having a
6 proximal end and a distal end, an active electrode disposed
7 near the distal end, and a connector near the proximal end of
8 the shaft for electrically coupling the active electrode to
9 the electrosurgical power supply; and
10 a return electrode adapted to be electrically
11 coupled to the electrosurgical power supply, the return
12 electrode defining a liquid path in electrical contact with

13 the return electrode, the liquid path having an inlet adapted
14 to be fluidly coupled to the electrically conductive liquid
15 supply for generating a current flow path from the active
16 electrode, through the body structure in the region of the
17 target site, and to the return electrode.

1 29. An electrosurgical system as in claim 28,
2 wherein the return electrode forms a portion of the shaft of
3 the electrosurgical probe.

1 30. An electrosurgical system as in claim 29
2 further including an insulating member circumscribing the
3 return electrode, the return electrode being proximally
4 recessed from the distal end of the shaft to minimize direct
5 contact between the return electrode and the target site.

1 31. An electrosurgical system as in claim 29,
2 wherein the return electrode is an inner tubular member
3 defining an axial lumen therein, the axial lumen having an
4 inlet in communication with the electrically conductive liquid
5 supply and an outlet in communication with the active
6 electrode.

1 32. An electrosurgical system as in claim 29,
2 wherein the return electrode is an outer tubular member, the
3 shaft further comprising an insulating member defining an
4 axial passage between the insulating member and the return
5 electrode, the axial passage having an inlet in communication
6 with the electrically conductive liquid supply and an outlet
7 in electrical and fluid communication with the active
8 electrode.

1 33. An electrosurgical system as in claim 28
2 further including a liquid supply instrument separate from the
3 electrosurgical probe, the return electrode forming a portion
4 of the liquid supply instrument.

1 34. An electrosurgical system as in claim 33
2 wherein the return electrode is a tubular member defining an
3 axial lumen therein, the axial lumen being electrically
4 connected to the tubular member and having an inlet in
5 communication with the liquid supply and an outlet for
6 discharging the electrically conductive liquid towards the
7 active electrode.

1 35. An electrosurgical system as in claim 34
2 wherein the liquid supply instrument comprises an electrically
3 insulating sheath around the tubular member, the tubular
4 member being proximally recessed from a distal end of the
5 sheath.

1 36. An electrosurgical system as in claim 28
2 wherein the active electrode comprises an electrode array
3 disposed near the distal end of the shaft, the array including
4 a plurality of electrically isolated electrode terminals
5 disposed over a contact surface.

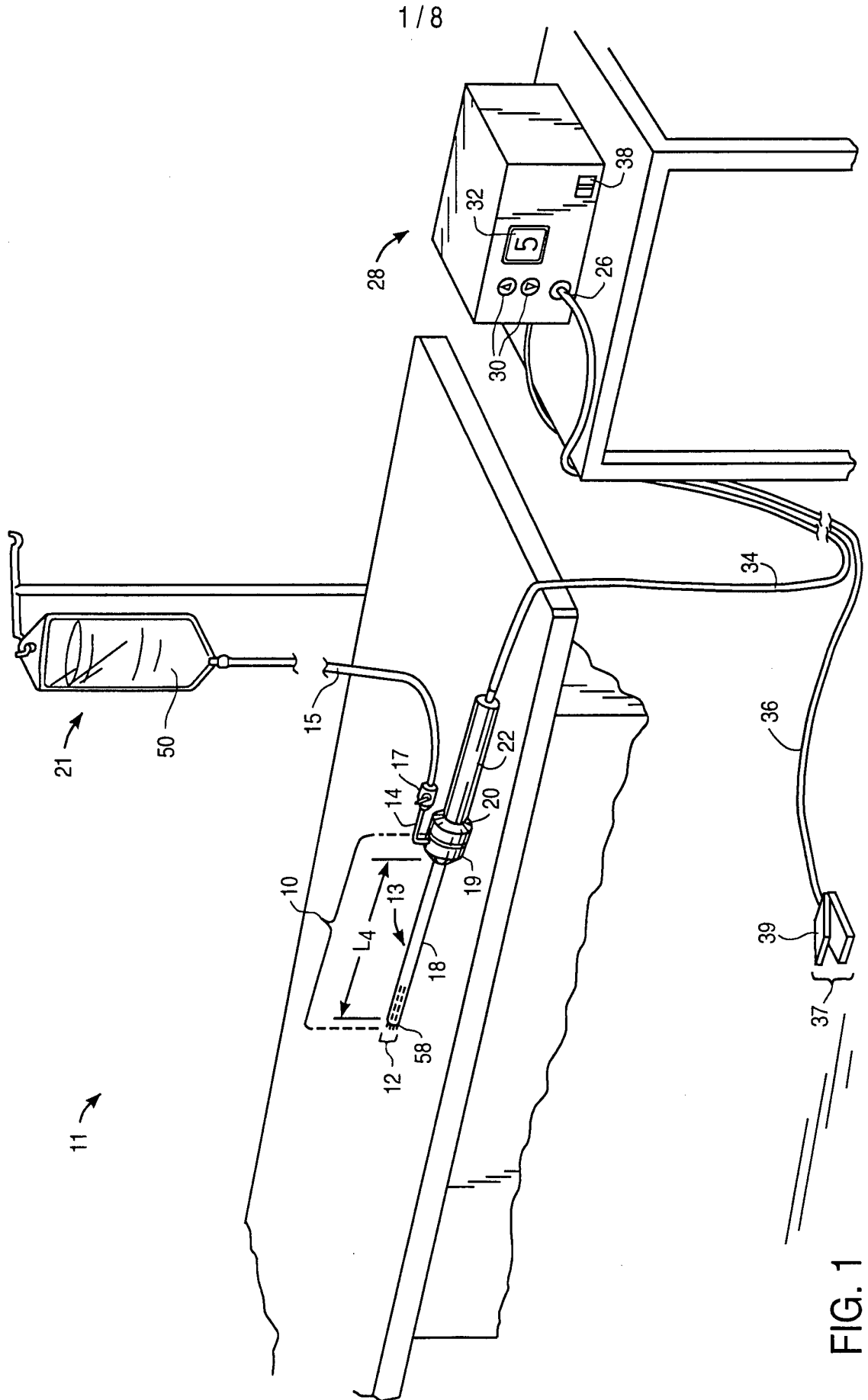

FIG. 1

2 / 8

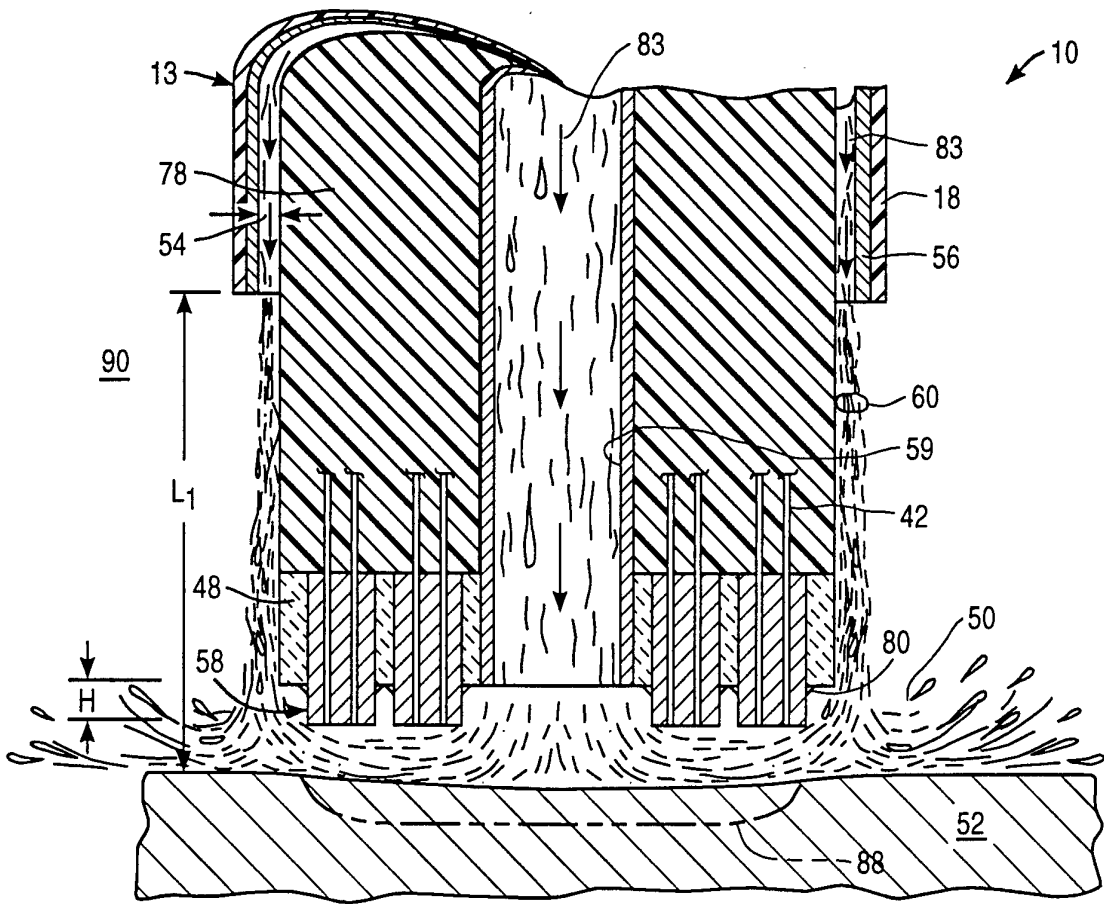

FIG. 2A

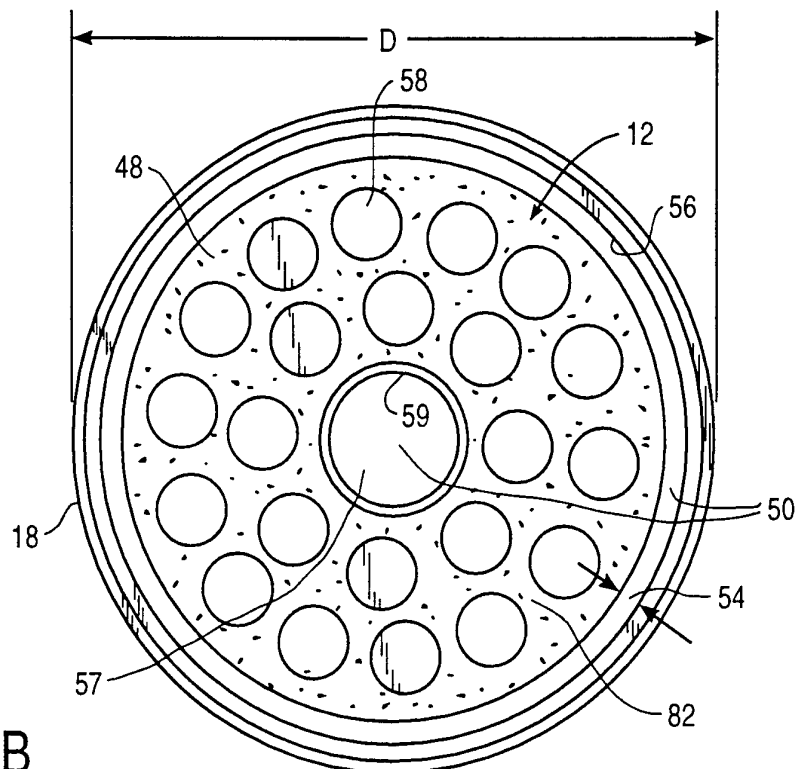

FIG. 2B

SUBSTITUTE SHEET (RULE 26)

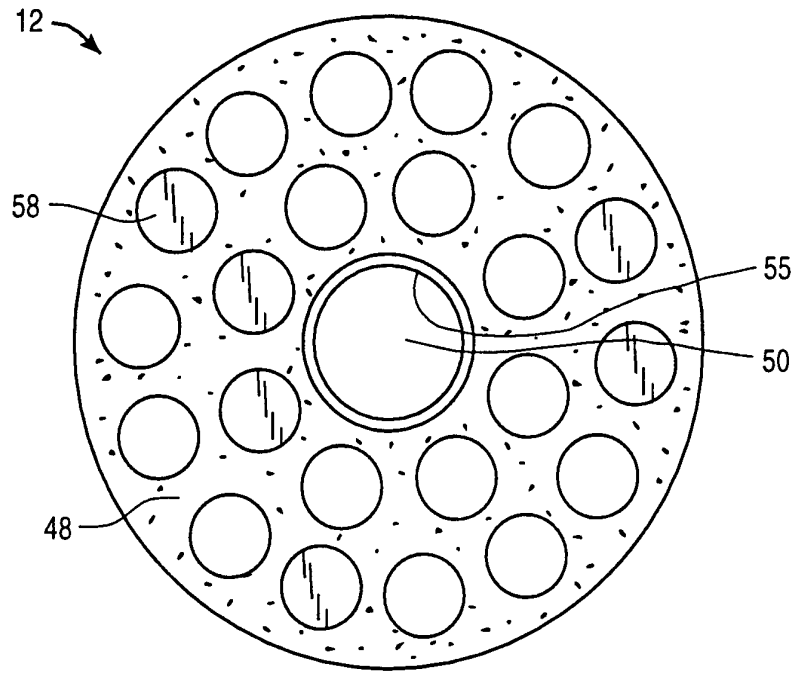

FIG. 4

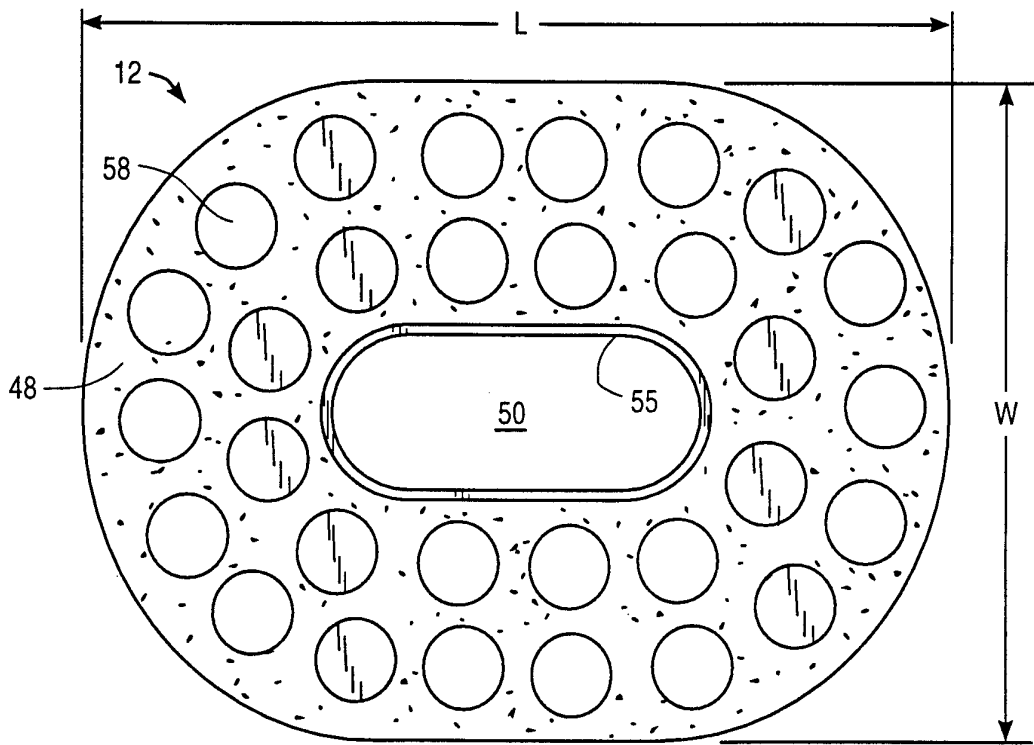

FIG. 5

5 / 8

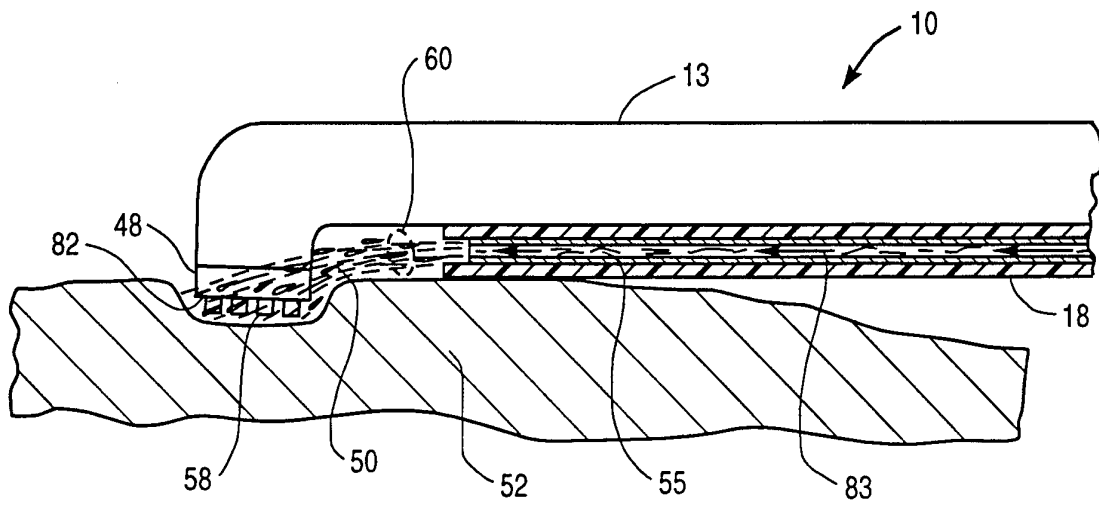

FIG. 6

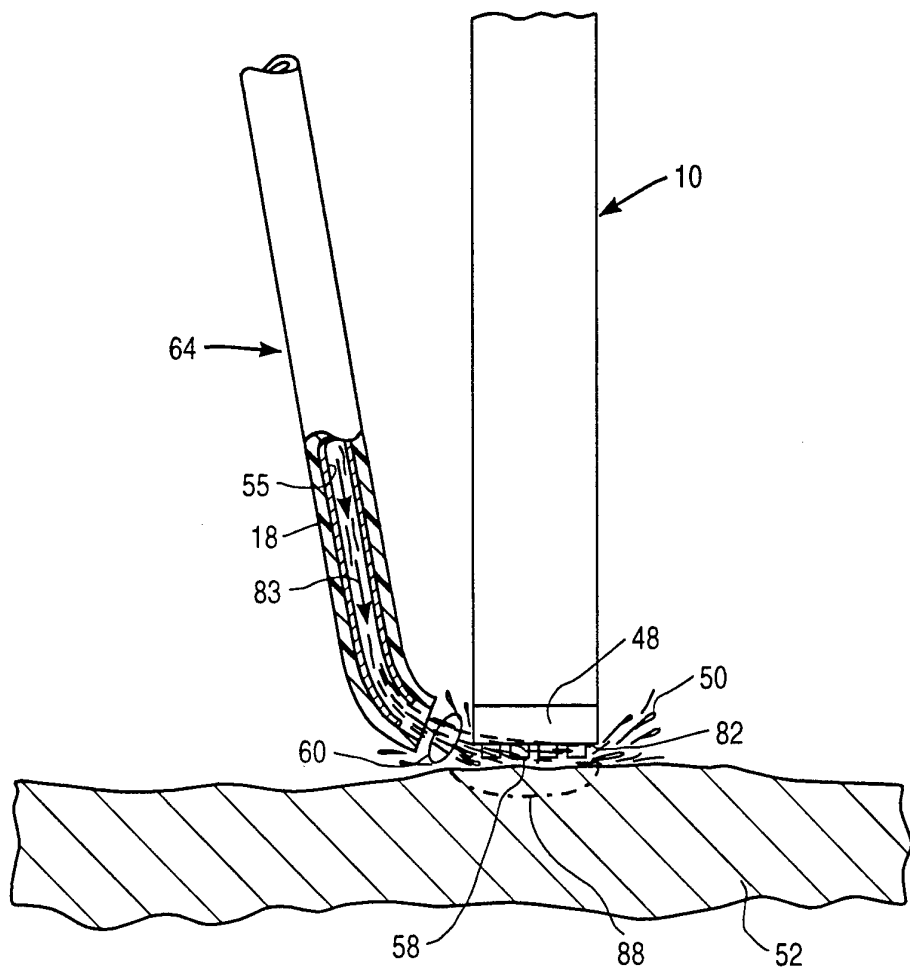

FIG. 7

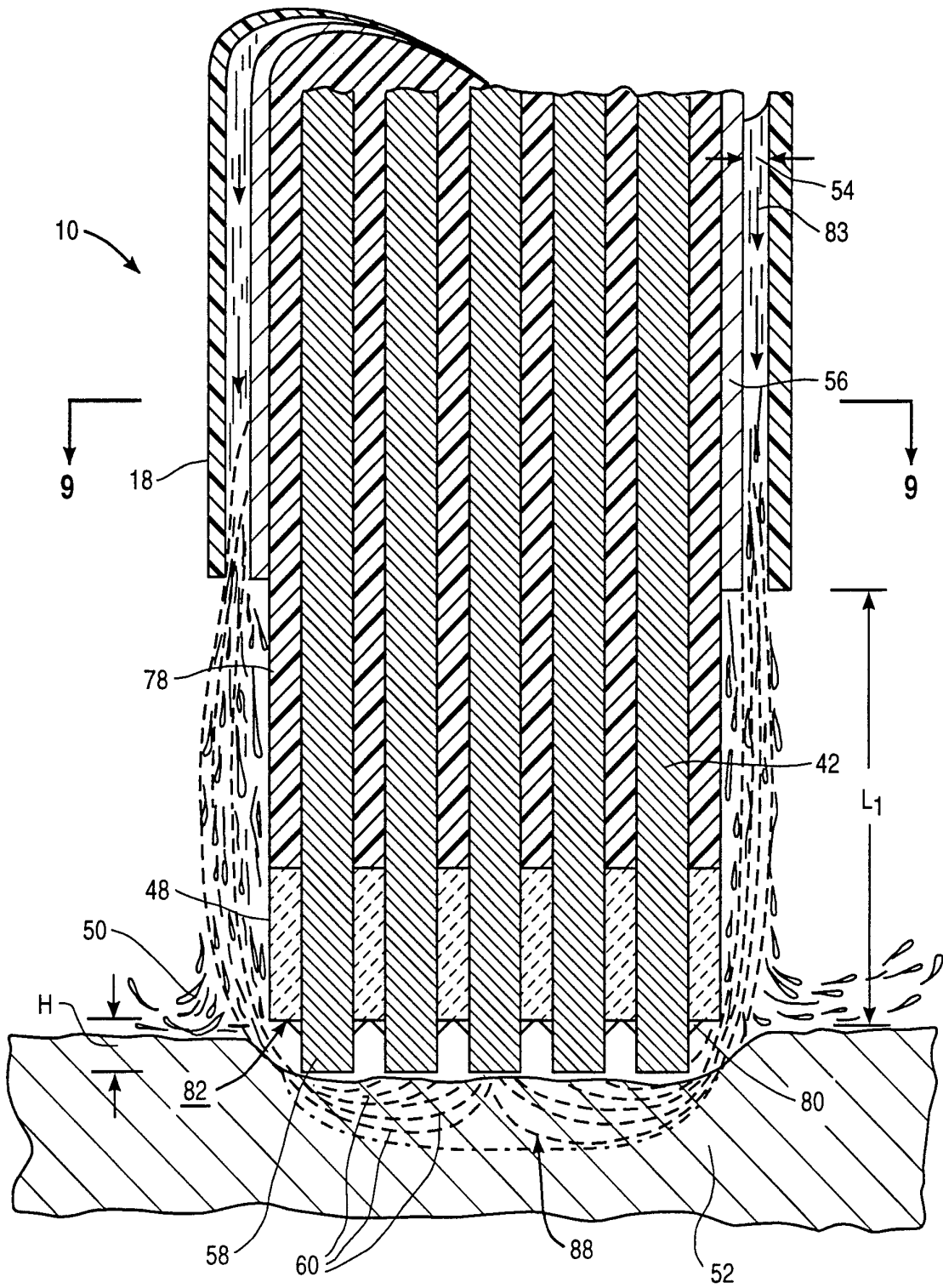

FIG. 8

SUBSTITUTE SHEET (RULE 26)

7/8

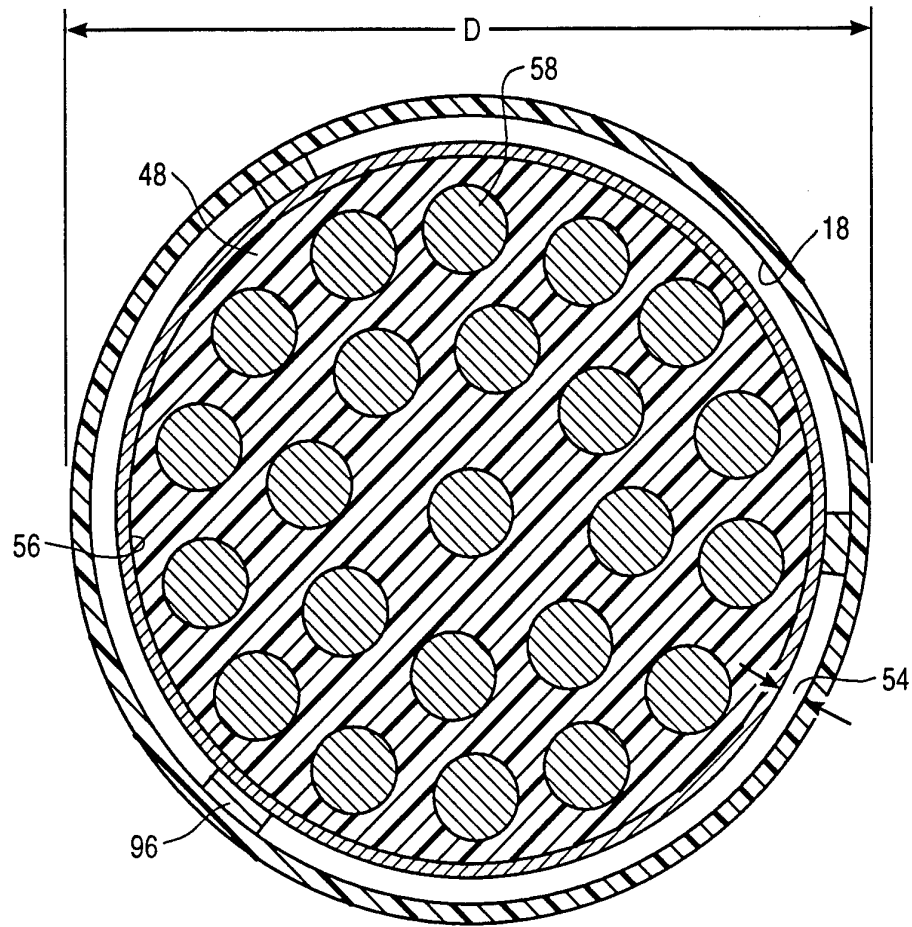

FIG. 9

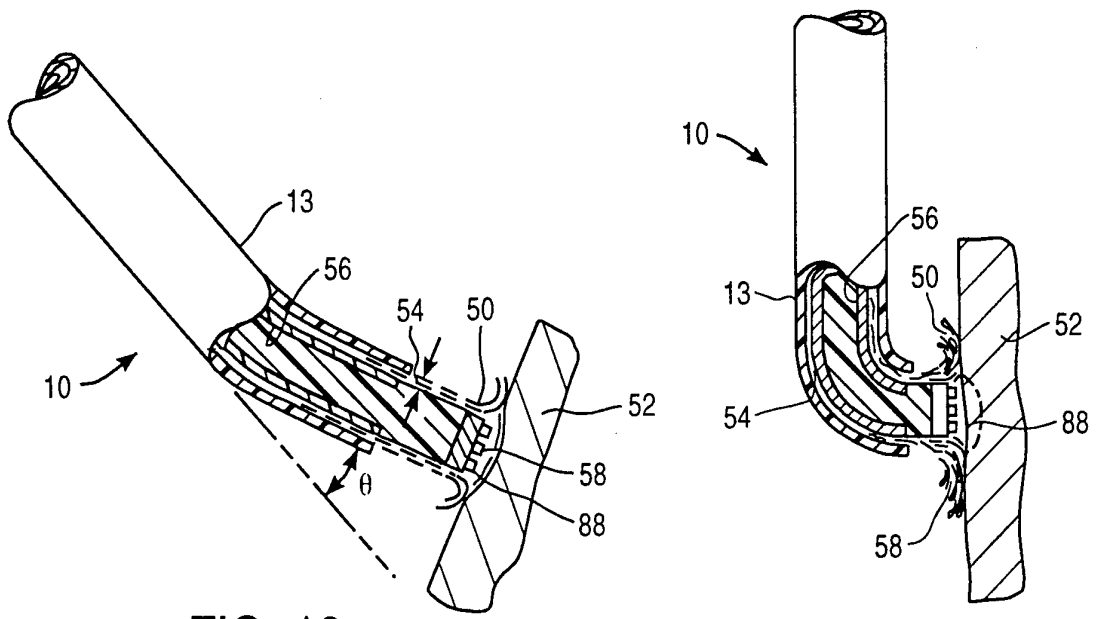

FIG. 10

FIG. 11

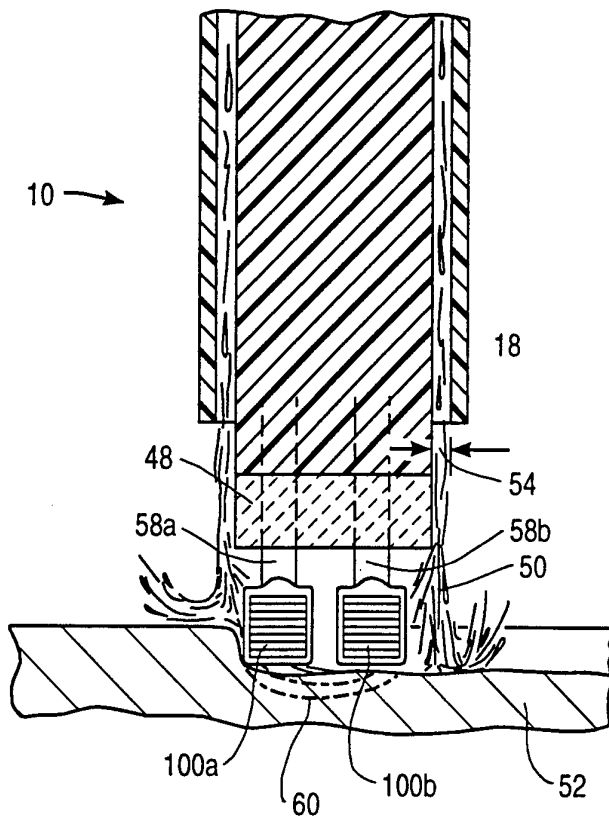

FIG. 12

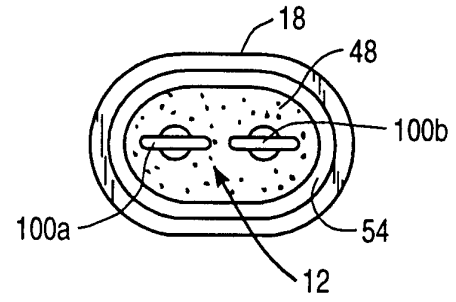

FIG. 13

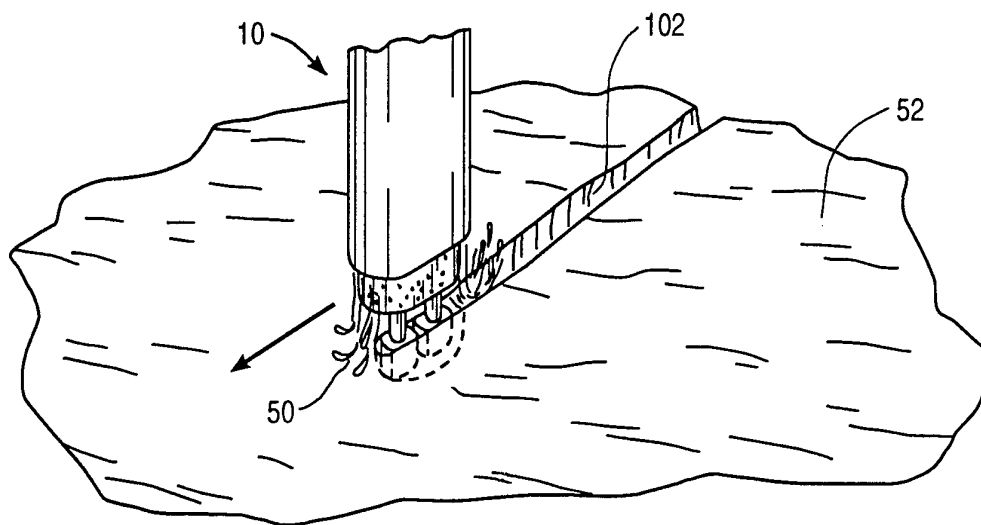

FIG. 14

INTERNATIONAL SEARCH REPORT

International application No.
PCT/US96/08077

A. CLASSIFICATION OF SUBJECT MATTER

IPC(6) :A61B 1/00

US CL :604/114

According to International Patent Classification (IPC) or to both national classification and IPC

B. FIELDS SEARCHED

Minimum documentation searched (classification system followed by classification symbols)

U.S. : 604/22, 41, 113, 114; 606/27-32, 35, 38, 41

Documentation searched other than minimum documentation to the extent that such documents are included in the fields searched

Electronic data base consulted during the international search (name of data base and, where practicable, search terms used)

C. DOCUMENTS CONSIDERED TO BE RELEVANT

Category*	Citation of document, with indication, where appropriate, of the relevant passages	Relevant to claim No.
Y	US, A, 4,967,765 (TURNER ET AL.) 06 November 1990, see entire patent.	1-36
Y	US, A, 4,860,752 (TURNER) 29 August 1989, see entire patent.	1-36
Y	US, A, 5,057,106 (KASEVICH ET AL.) 15 October 1991, see entire patent.	1-36

Further documents are listed in the continuation of Box C. See patent family annex.

* Special categories of cited documents:	*T* later document published after the international filing date or priority date and not in conflict with the application but cited to understand the principle or theory underlying the invention
A document defining the general state of the art which is not considered to be part of particular relevance	*X* document of particular relevance; the claimed invention cannot be considered novel or cannot be considered to involve an inventive step when the document is taken alone
E earlier document published on or after the international filing date	*Y* document of particular relevance; the claimed invention cannot be considered to involve an inventive step when the document is combined with one or more other such documents, such combination being obvious to a person skilled in the art
L document which may throw doubts on priority claim(s) or which is cited to establish the publication date of another citation or other special reason (as specified)	*&* document member of the same patent family
O document referring to an oral disclosure, use, exhibition or other means	
P document published prior to the international filing date but later than the priority date claimed	

Date of the actual completion of the international search 06 AUGUST 1996	Date of mailing of the international search report 16 SEP 1996
---	--

Name and mailing address of the ISA/US
Commissioner of Patents and Trademarks
Box PCT
Washington, D.C. 20231

Authorized officer

MANUEL MENDEZ

Facsimile No. (703) 305-3590

Telephone No. (703) 308-2221