



(86) **Date de dépôt PCT/PCT Filing Date:** 2014/06/11
 (87) **Date publication PCT/PCT Publication Date:** 2015/12/17
 (85) **Entrée phase nationale/National Entry:** 2016/11/24
 (86) **N° demande PCT/PCT Application No.:** CA 2014/050545
 (87) **N° publication PCT/PCT Publication No.:** 2015/188248

(51) **Cl.Int./Int.Cl. F26B 3/347** (2006.01),
F26B 5/04 (2006.01)
 (71) **Demandeur/Applicant:**
ENWAVE CORPORATION, CA
 (72) **Inventeurs/Inventors:**
DURANCE, TIMOTHY D., CA;
FU, JUN, CA
 (74) **Agent:** OYEN WIGGS GREEN & MUTALA LLP

(54) **Titre : DESHYDRATATION SOUS VIDE PAR MICRO-ONDES DE MATIERES ORGANIQUES**
 (54) **Title: MICROWAVE VACUUM-DRYING OF ORGANIC MATERIALS**

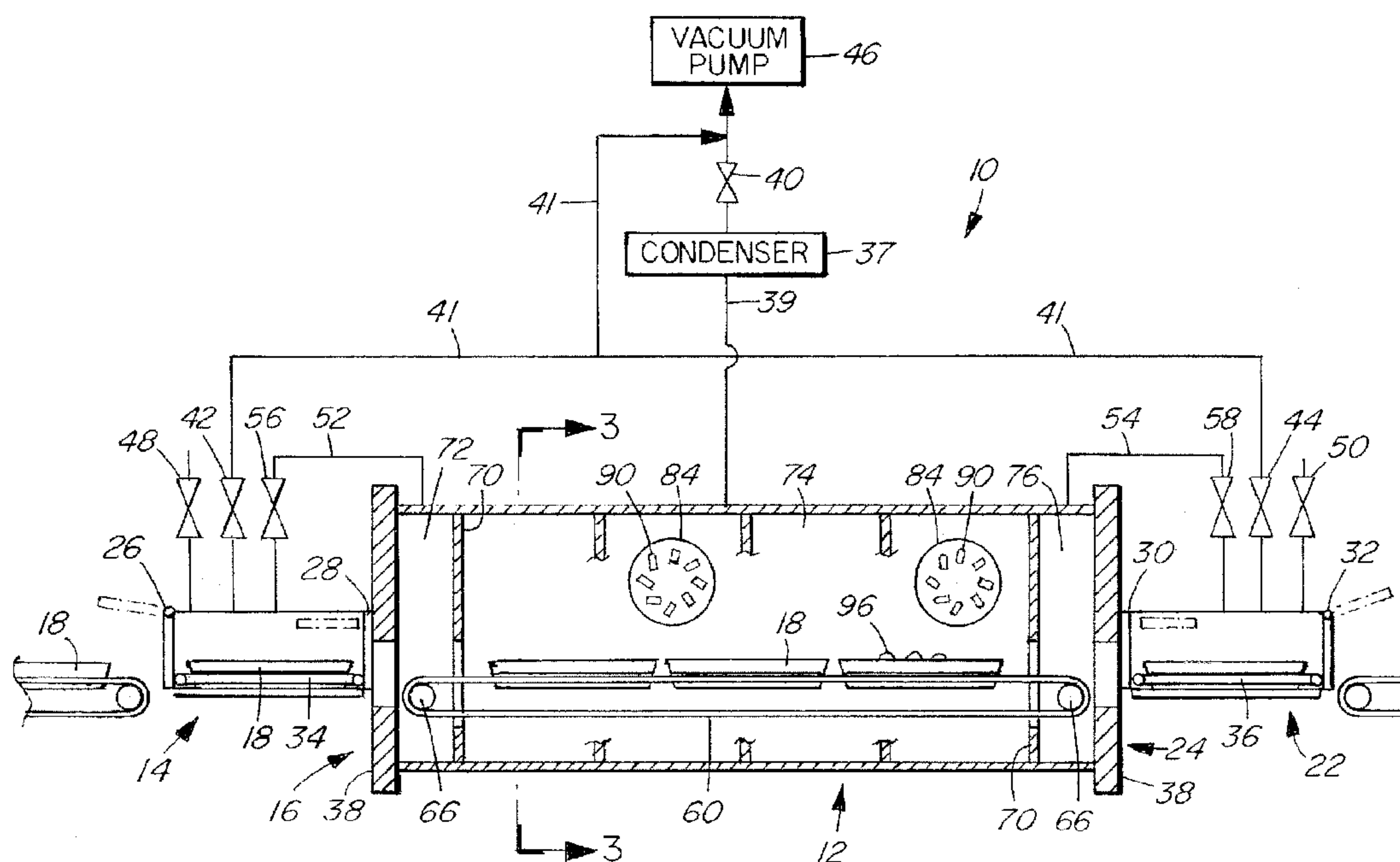

FIG. 1

(57) **Abrégé/Abstract:**

An apparatus and method for microwave vacuum-drying of organic materials such as food products. The dehydration apparatus (10) has a vacuum chamber (12) with a loading module (14) at one end and a discharge module (22) at the other. The vacuum chamber has access doors (80) spaced between the input end (16) and the discharge end (24) which provide operator and maintenance access. Microwave generators (86) are mounted on each access door and arranged to radiate through a microwave chamber and microwave-transparent window on the access door into the vacuum chamber. The waveguides on a respective access door are oriented to minimize microwave interference between the magnetrons on that door. A conveyor (60) in the vacuum chamber moves the organic material (96) on trays (18) through the vacuum chamber.

(12) INTERNATIONAL APPLICATION PUBLISHED UNDER THE PATENT COOPERATION TREATY (PCT)

(19) World Intellectual Property
Organization
International Bureau

WIPO | PCT

(10) International Publication Number
WO 2015/188248 A1(43) International Publication Date
17 December 2015 (17.12.2015)

(51) International Patent Classification:

F26B 3/347 (2006.01) F26B 5/04 (2006.01)

(21) International Application Number:

PCT/CA2014/050545

(22) International Filing Date:

11 June 2014 (11.06.2014)

(25) Filing Language:

English

(26) Publication Language:

English

(71) Applicant: ENWAVE CORPORATION [CA/CA]; 2000 - 1066 West Hastings Street, Vancouver, British Columbia V6E 3X2 (CA).

(72) Inventors: DURANCE, Timothy D.; 3491 West 38th Ave., Vancouver, British Columbia V6N 2X8 (CA). FU, Jun; 1168 Riverside Dr., Port Coquitlam, British Columbia V3B 8B3 (CA).

(74) Agents: MCGRUDER, David J. et al.; Oyen Wiggs Green & Mutala LLP, 480 - The Station, 601 West Cordova Street, Vancouver, British Columbia V6B 1G1 (CA).

(81) Designated States (unless otherwise indicated, for every kind of national protection available): AE, AG, AL, AM,

AO, AT, AU, AZ, BA, BB, BG, BH, BN, BR, BW, BY, BZ, CA, CH, CL, CN, CO, CR, CU, CZ, DE, DK, DM, DO, DZ, EC, EE, EG, ES, FI, GB, GD, GE, GH, GM, GT, HN, HR, HU, ID, IL, IN, IR, IS, JP, KE, KG, KN, KP, KR, KZ, LA, LC, LK, LR, LS, LT, LU, LY, MA, MD, ME, MG, MK, MN, MW, MX, MY, MZ, NA, NG, NI, NO, NZ, OM, PA, PE, PG, PH, PL, PT, QA, RO, RS, RU, RW, SA, SC, SD, SE, SG, SK, SL, SM, ST, SV, SY, TH, TJ, TM, TN, TR, TT, TZ, UA, UG, US, UZ, VC, VN, ZA, ZM, ZW.

(84) Designated States (unless otherwise indicated, for every kind of regional protection available): ARIPO (BW, GH, GM, KE, LR, LS, MW, MZ, NA, RW, SD, SL, SZ, TZ, UG, ZM, ZW), Eurasian (AM, AZ, BY, KG, KZ, RU, TJ, TM), European (AL, AT, BE, BG, CH, CY, CZ, DE, DK, EE, ES, FI, FR, GB, GR, HR, HU, IE, IS, IT, LT, LU, LV, MC, MK, MT, NL, NO, PL, PT, RO, RS, SE, SI, SK, SM, TR), OAPI (BF, BJ, CF, CG, CI, CM, GA, GN, GQ, GW, KM, ML, MR, NE, SN, TD, TG).

Published:

— with international search report (Art. 21(3))

(54) Title: MICROWAVE VACUUM-DRYING OF ORGANIC MATERIALS

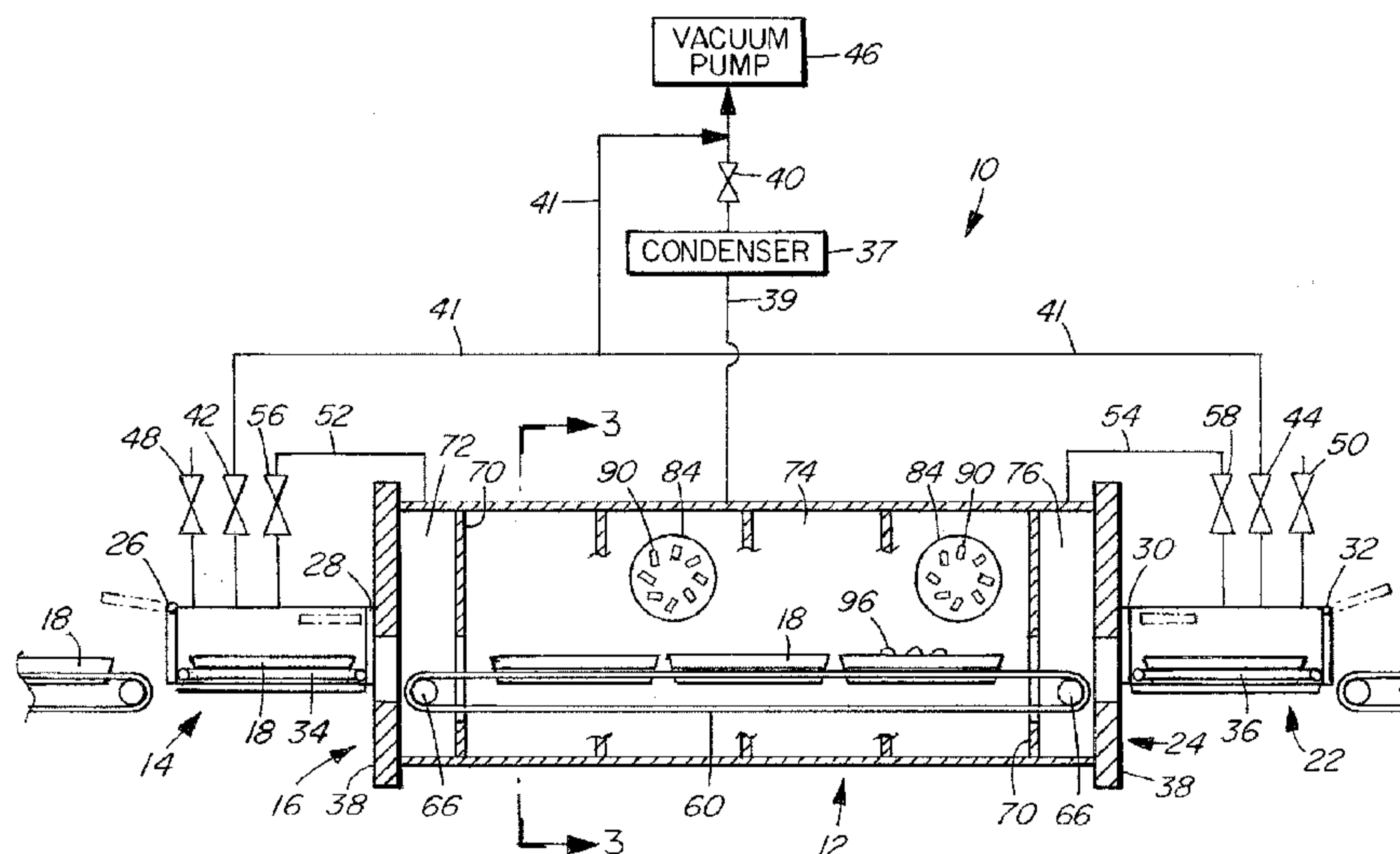

FIG. 1

(57) Abstract: An apparatus and method for microwave vacuum-drying of organic materials such as food products. The dehydration apparatus (10) has a vacuum chamber (12) with a loading module (14) at one end and a discharge module (22) at the other. The vacuum chamber has access doors (80) spaced between the input end (16) and the discharge end (24) which provide operator and maintenance access. Microwave generators (86) are mounted on each access door and arranged to radiate through a microwave chamber and microwave-transparent window on the access door into the vacuum chamber. The waveguides on a respective access door are oriented to minimize microwave interference between the magnetrons on that door. A conveyor (60) in the vacuum chamber moves the organic material (96) on trays (18) through the vacuum chamber.

MICROWAVE VACUUM-DRYING OF ORGANIC MATERIALS

Background of the Invention

5 The invention pertains to apparatuses and methods for microwave vacuum-drying of organic materials, such as food products.

Dehydration of organic materials is commonly done in the food processing industry and in the production of biologically-active materials. It may be
10 done in order to preserve the products for storage, or to create a product that is used in the dehydrated form, for example dried herbs and various kinds of chips. One method employed to dehydrate food products and biologically-active materials is microwave vacuum dehydration. Examples of this in the patent literature include US 6,442,866, Wefers; WO 2009/049409, Durance et
15 al.; WO 2009/033285, Durance et al.; and WO 2011/085467, Fu et al.

Microwave vacuum-drying is a rapid method that can yield products with improved quality compared to air-dried and freeze-dried products. Because the drying is done under reduced pressure, the boiling point of water and the oxygen content of the atmosphere are lowered, so food and medicinal
20 components sensitive to oxidation and thermal degradation can be retained to a higher degree than by air-drying. The drying process is also much faster than air- and freeze-drying. However, in some prior art microwave-vacuum driers, substantial disassembly of the apparatus is required to provide access to the interior of the vacuum chamber for purposes of cleaning and repair. In
25 others, relatively high power microwave generators are required, which are expensive and increase the risk of microwave arcing within the vacuum chamber, and thus limit the range of pressures at which the chamber can be operated.

Summary of the Invention

According to one aspect of the invention, there is provided an apparatus for
5 dehydrating organic material. A vacuum chamber has an input end for
introduction of the organic material into the vacuum chamber and a discharge
end for removal of the material. The vacuum chamber has a plurality of
access doors that are longitudinally spaced apart between the input end and
the discharge end of the vacuum chamber, each covering a respective access
10 port. Each access door has a plurality of magnetrons, each magnetron having
a respective waveguide. Each access door has a respective microwave-
transparent window arranged between the waveguides and the vacuum
chamber. The magnetrons and waveguides on a respective access door are
arranged to radiate microwaves through the microwave-transparent window
15 into the vacuum chamber. The waveguides on each access door are oriented
to minimize microwave interference between the magnetrons on the access
door. This minimization of microwave interference may be done by having
the waveguide openings in the face of an access door oriented at an angle
different from the openings of the other waveguides on the access door. The
20 apparatus has means for reducing pressure inside the vacuum chamber, means
for loading the organic material into the input end of the vacuum chamber,
means for moving the material through the vacuum chamber from the input
end to the discharge end, and means for unloading the dehydrated organic
material at the discharge end.

25

According to another aspect of the invention, there is provided an apparatus
for dehydrating organic material, comprising a vacuum chamber having a

vacuum chamber access door covering an access port, a plurality of magnetrons positioned on the access door and arranged to radiate microwaves through a microwave-transparent window into the vacuum chamber, each magnetron having a respective waveguide. A microwave-transparent window is arranged between the waveguides and the vacuum chamber. The magnetrons and waveguides on the access door are arranged to radiate microwaves through the microwave-transparent window into the vacuum chamber. The waveguides on the access door are oriented to minimize interference between the magnetrons. The apparatus has means for reducing pressure inside the vacuum chamber.

According to another aspect of the invention, there is provided a method for dehydrating an organic material. The material is introduced into a vacuum chamber, the chamber being at a pressure less than atmospheric. The organic material is moved through the vacuum chamber from an input end to a discharge end while applying microwave radiation from a plurality of magnetrons positioned on a plurality of access doors of the vacuum chamber through respective microwave-transparent windows to dehydrate the organic material, the waveguides being oriented to minimize interference between the magnetrons on a respective access door. The dehydrated organic material is then removed from the vacuum chamber.

According to another aspect of the invention, there is provided a method for dehydrating an organic material. The material is introduced into a vacuum chamber and the pressure in the vacuum chamber is reduced to less than atmospheric. Microwave radiation is applied from a plurality of magnetrons positioned on an access door of the vacuum chamber through a microwave-transparent window into the vacuum chamber to dehydrate the organic

material. Each magnetron has a respective waveguide and the waveguides are oriented to minimize microwave interference between the magnetrons. The dehydrated organic material is then removed from the vacuum chamber.

5 By providing access doors on the vacuum chamber and positioning the microwave generators and microwave-transparent window on the doors, the invention permits operator and maintenance access to the interior of the vacuum chamber and to the microwave generators, without the need for disassembling the dehydration apparatus. The arrangement of the waveguides
10 to minimize interference between the magnetrons on a given access door (i.e. interference between the microwaves produced by each said magnetron) makes it possible to use multiple magnetrons on each door. Such magnetrons can according be relatively low power (and inexpensive) units, which is favorable to the suppression of arcing in the vacuum chamber.

15

Examples of organic materials suitable for dehydration by the invention include fruit, either whole, puree or pieces, either frozen or un-frozen, including banana, mango, papaya, pineapple, melon, apples, pears, cherries, berries, strawberries, pomegranate, peaches, apricots, plums, grapes, oranges,
20 lemons, grapefruit; vegetables, either fresh or frozen, whole, puree or pieces, including peas, beans, corn, carrots, tomatoes, peppers, herbs, potatoes, beets, turnips, squash, onions, garlic, mushrooms; fruit and vegetable juices; pre-cooked grains including rice, oats, wheat, barley, corn, flaxseed; vegetable gums; drugs; material pieces in which a hydrocolloid or gum surrounds and
25 encapsulates a droplet or particle of a relatively less stable material as a means of protecting and stabilizing the less sensitive material; meats, fish and seafoods, either fresh or frozen, either whole or pieces; dairy products such as cheese and curds.

These and other features of the invention will be apparent from the following description and drawings of the preferred embodiments.

5 **Brief Description of the Drawings**

Figure 1 is a schematic longitudinal section view of a dehydration apparatus according to one embodiment of the invention.

10 Figure 2 is a top plan view, partly cutaway, of the apparatus of Figure 1.

Figure 3 is a sectional view across the vacuum chamber on the line 3-3 of Figure 1.

15 Figure 4 is an elevational view of a section of the vacuum chamber of the apparatus of Figure 1, with the access door in the open position.

Figure 5 is a schematic view of a production line incorporating the dehydration apparatus of Figure 1.

20

Figure 6 is a perspective view of an embodiment of the dehydration apparatus for batch production.

Figure 7 is sectional view across the apparatus of Figure 6.

25

Description of the Preferred Embodiments

Referring to Figures 1 to 4, the dehydrating apparatus **10** has a vacuum chamber **12** through which a tray of organic material is conveyed for dehydra-
5 tion. A loading module **14** is positioned at the input end **16** of the vacuum chamber for introduction of trays **18** of organic material into the vacuum chamber **12**. The vacuum chamber is generally cylindrical, with a circumferential side wall **20**. A discharge module **22** is positioned at the output or discharge end **24** of the vacuum chamber for removal of the trays. The
10 loading module **14** and discharge module **24** each have a pair of airlock doors, respectively **26, 28** and **30, 32** (their open position being shown by dotted lines in Figure 1). These permit the trays to be loaded into and unloaded from the vacuum chamber, while maintaining the vacuum chamber at the reduced pressure required for the dehydration process. The loading and discharge
15 modules **14, 24** have motor-driven conveyors **34, 36**, respectively, for moving the trays. The dehydration apparatus **10** is oriented with its longitudinal axis substantially horizontal, supported on stands **38**.

The vacuum chamber **12** is connected via a shut-off valve **40**, a condenser **37**
20 and vacuum conduit **39** to a vacuum pump **46** or the vacuum system of a plant. The loading and discharge modules **14, 22** are connected to the vacuum pump **46** or the vacuum system via a vacuum conduit **41** and shut-off valves **42** or **44**. The loading and discharge modules are vented by discharge shut-off valves **48** and **50** respectively. A further discharge valve (not shown) is
25 provided for venting the vacuum chamber. The loading and discharge modules **14, 22** are connected to the vacuum chamber **12** for pressure equalization by means of equalization conduits **52** and **54** and the associated shut-off valves **56** and **58**, respectively.

The vacuum chamber **12** has a conveyor **60** extending longitudinally through it and arranged to support and convey the trays **18**. The conveyor comprises a pair of spaced-apart belts **62**, **64** that run on rollers **66** adjacent to the inlet and the outlet ends of the vacuum chamber. The tray **18** has an outwardly-
5 projecting flange **68** at its upper edge. The tray **18** is supported by its flange **68** on the belts **62**, **64**, with the body of the tray fitting in the space between the two belts, as best seen in Figures 2 and 3. The conveyor **60** is powered by a motor (not shown).

10

The vacuum chamber is divided by microwave shielding **70** into an inlet zone **72**, a treatment zone **74** and a cooling zone **76**. The shields **70** are metal plates having slots for the passage of the conveyor **60** and the tray **18**. Optionally, the inlet and outlet end shields may be bent parallel to the conveying direction
15 in the region of the passage openings near to the conveyor **60** to keep the inlet and cooling zones **72** and **76** respectively substantially free of microwave radiation.

20

The vacuum chamber **12** has a plurality of access doors **80** pivotally attached
20 by hinges **82** to opposite sides of the vacuum chamber. Each access door covers an access port **84**. There are four access doors **80** in the illustrated embodiment, though it will be understood that the drying apparatus may have any suitable number, depending upon the length and intended capacity of the vacuum chamber. The access doors are positioned in a staggered arrangement
25 on the two lateral sides of the vacuum chamber, as best seen in Figures 2 and 3. The access ports have a short open cylindrical channel **85** between the port opening and the side wall **20** of the vacuum chamber **12**. These channels are sloped inwardly to aid in drainage of condensate and wash water. The access

ports are sized to provide operator and maintenance access to the interior of the vacuum chamber. For example, the access ports may be about 60 cm in diameter on a vacuum chamber having a diameter of about 140 cm. The access doors **80** latch securely and releasably to the vacuum chamber and form an airtight seal with the rim of the ports **84**. Within the treatment zone **74**, microwave shields **70** are positioned between adjacent access doors.

A set of magnetrons (microwave generators) **86** is mounted inside an inner wall **88** of each access door, with the magnetron antennas protruding into respective waveguides **90**. The waveguides are recesses in the inner wall **88** of the access doors, rectangular in elevation view, open at the inner wall or face **88** of the access door and each oriented at an angle different from that of the other waveguides of the access door. The different angles reduce interference between magnetrons, thereby minimizing heating of one magnetron by another, reducing the potential for arcing in the vacuum chamber and resulting in a more uniform microwave field in the vacuum chamber. In the illustrated embodiment, there are eight magnetrons in each access door **80**. More or fewer may be provided, depending upon the power and drying requirements for a particular application. As best seen in Figure 4, the magnetrons **86** and waveguides are arranged in a generally circular array around the face of the door, each oriented at an angle relative to the other magnetrons and waveguides in the set. The magnetrons are connected to a power source (not shown) to provide the required electric power. An exemplary set of magnetrons on each access door comprises eight magnetrons of 1.5 kW each, for a power output of 12 kW for the set. The apparatus as illustrated, having four access doors, would accordingly have a total power output of 48 kW. Coolant is pumped to circulate around the magnetrons from a cooling liquid refrigeration unit (not shown).

A microwave-transparent window **92**, made for example of Teflon, is provided on each access door **80** at its inner side, in close proximity to the wall of the vacuum chamber. A microwave chamber **94** is positioned
5 between the magnetrons **86** and the window **92**. There is an airtight seal between the window **92** and the access door **80**; when the access door is closed and the vacuum chamber is evacuated, the window **92** forms a wall of the vacuum chamber. Outside the window, in the microwave chamber **94**, the pressure remains atmospheric.

10

The dehydration apparatus **10** includes a programmable logic controller (PLC), programmed and connected to control the operation of the system, including the conveyor drive motors, the airlock doors, the microwave generators, the vacuum pump, condensor, the refrigerant pump and the
15 vacuum shut-off valves.

The dehydration apparatus **10** operates according to the following method. The airlock doors **28** and **32** are closed. The vacuum pump, conveyor drive motors and microwave generators are actuated, all under the control of the
20 PLC. Pressure within the vacuum chamber is reduced to a desired pressure, e.g. in the range of 0.01 to 100 Torr (1.333 to 13,332 Pa), alternatively about 0.1 to 30 Torr (13.33 to 4,000 Pa). The organic material **96** to be dehydrated is put into a tray **18** and the tray is placed in the loading module **14**. The outer airlock door **26** and shut-off valve **48** are closed and the loading module is
25 evacuated to the pressure of the vacuum chamber. The inner airlock door **28** is then opened and the tray is transported, by the conveyors **34** and **60**, into the vacuum chamber **12**. Once the tray is fully inside the vacuum chamber, the loading chamber **14** is prepared for receiving a second tray, by closing the

inner airlock door **28** and the shut-off valves **42** and **56**, and opening the shut-off valve **48** to vent the loading module to atmospheric pressure, and opening the outer airlock door **26**. The dehydration apparatus is thus able to process multiple trays of organic material at the same time, in a continuous process.

5 Inside the vacuum chamber **12**, the tray is moved along the conveyor **60**, from the inlet zone **72** to the treatment zone **74**, where the microwave generators **86** irradiate the material and dehydrate it, i.e. reduce its moisture to a desired level. The tray then passes to the cooling zone **76**, in which it is allowed to cool. It then enters the discharge module **22**, where it is conveyed toward the

10 outer airlock door **32**. The inner airlock door **30** is then closed, the shut-off valves **44**, **58** are closed, the valve **50** is opened to vent the discharge module to the atmosphere, the outer airlock door **32** is opened and the tray is removed. The discharge module is prepared for the next tray to be removed from the vacuum chamber by closing the outer airlock door **32**, evacuating the

15 discharge module to the reduced pressure of the vacuum chamber, and opening the inner airlock door **30**. Following either loading or discharge of a tray from the loading modules or discharge module, the shut-off valve **40** can be momentarily closed and the vacuum pump can draw gases directly from the loading or discharge module, through the vacuum conduit **41**, without

20 disturbing the vacuum in the vacuum chamber **12**.

As shown in Figure 5, the dehydration apparatus **10** may be incorporated into a production line **100**. The vacuum chamber **12**, the loading module **14** and discharge module **22** are arranged together as described above. Upstream of

25 the loading module **14** is a filling station **102** for filling the trays with organic material to be dehydrated. The filled trays are then conveyed to the loading module **14**. An emptying station **104** for emptying the trays of their dehy-

drated contents is downstream of the discharge module **22**, optionally followed by a washing station **106** for washing the emptied trays.

Optionally, and as a matter of manufacturing and operational convenience, the vacuum chamber may be built of separate vacuum chamber modules. Such a module comprises a longitudinal section of the vacuum chamber having an access door **80** and access port **84**, the modules being configured to connect together end-to-end in an airtight mating attachment. A vacuum chamber can be built to any desired length or capacity using standard modules. Transportation of the drying apparatus from the manufacturer to the user for assembly is facilitated by modular design, and a damaged module can be repaired without substantially affecting the rest of the apparatus.

The invention also includes a dehydration apparatus and method in which there is a single access door to the vacuum chamber, rather than the multiple ones as described above. Referring to Figure 6 and 7, a dehydration apparatus **200** comprises a vacuum chamber **202** having a cylindrical side wall **204** and end walls **206**, and having a single access door **80** with a set of microwave generators **86** and microwave-transparent window **92**. The dehydration apparatus **200** is substantially the same as the apparatus **10** as described above, except that it does not have means to convey the tray of organic material through the vacuum chamber **202**, and is not adapted for connection to a loading module or discharge module, these modules not being required as the access door **80** is to be opened to load and unload the tray of organic material. Nor is the vacuum chamber divided into sections by microwave shielding **70**, as in apparatus **10**. The drying apparatus **200** is accordingly intended for batch drying rather than a continuous process. The tray **18** of organic material to be dehydrated is placed onto a stand **208** in the vacuum

chamber **202** through the access port **84**. The access door **80** is then sealed and the vacuum chamber is evacuated. After dehydration, the vacuum chamber is vented to the atmosphere, the access door is opened and the tray of dehydrated materials is removed. Such operation may be mechanized or done
5 manually by an operator.

Throughout the preceding description and the drawings, in which corresponding and like parts are identified by the same reference characters, specific details are set forth in order to provide a more thorough understanding to
10 persons skilled in the art. However, well known elements may not have been shown or described to avoid unnecessary detail. Accordingly, the description and drawings are to be regarded in an illustrative, rather than a restrictive, sense. The scope of the invention is defined by the claims which follow.

CLAIMS:

1. An apparatus (10) for dehydrating organic material (96), comprising:

a vacuum chamber (12) having an input end (16) for introduction of the organic material into the vacuum chamber and a discharge end (24) for removal of the organic material;

the vacuum chamber having a plurality of access doors (80), each access door covering a respective access port (84) into the vacuum chamber, the access doors being longitudinally spaced apart along the vacuum chamber between the input end and the discharge end;

each said access door having a plurality of magnetrons (86), each magnetron having a respective waveguide;

each said access door having a respective microwave-transparent window (92) arranged between the waveguides and the vacuum chamber;

the plurality of magnetrons and waveguides on a respective access door being arranged to radiate microwaves through the microwave-transparent window into the vacuum chamber;

the waveguides on a respective access door being oriented to minimize microwave interference between the magnetrons on said access door;

means (39, 46) for reducing pressure inside the vacuum chamber;

means (14) for loading the organic material into the input end of the vacuum chamber;

means (60) for moving the organic material through the vacuum chamber from the input end to the discharge end thereof; and

means (22) for unloading the dehydrated organic material from the vacuum chamber at the discharge end thereof.

2. An apparatus according to claim 1, wherein each waveguide has an opening in a face of a respective access door, each opening being oriented at an angle different from the openings of the other waveguides on said access door.
3. An apparatus according to claim 1 or 2, wherein the access doors are positioned in a staggered arrangement along opposed sides of the vacuum chamber, with longitudinally-adjacent access doors being positioned on opposed sides of the vacuum chamber.
4. An apparatus according to claim 1, 2 or 3, wherein the access doors are pivotally attached (82) to the vacuum chamber.
5. An apparatus according to any one of claims 1-4, wherein each micro-wave-transparent window is mounted on a respective access door.
6. An apparatus according to any one of claims 1-5, wherein the magnetrons on each access door are arranged in a generally circular array.

7. An apparatus according to any one of claims 1-6, wherein the access ports comprise an open channel (85) between each respective access port opening and the side wall (20) of the vacuum chamber, and the channels (85) slope downward from the respective access port opening to the side wall.
8. An apparatus according to any one of claims 1-7, further comprising a microwave chamber (94) between the magnetrons on a respective access door and the respective microwave-transparent window, the microwave chamber being adapted to be at atmospheric pressure.
9. An apparatus according to any one of claims 1-8, wherein the means for moving the organic material comprises a conveyor arranged to transport a tray (18) of the organic material.
10. An apparatus according to claim 9, wherein the conveyor comprises a pair of spaced-apart belts (62, 64) that engage a flange (68) of the tray.
11. An apparatus according to any one of claims 1-10, wherein the means for loading and the means for unloading comprise air locks.
12. An apparatus according to any one of claims 1-11, wherein the vacuum chamber comprises a plurality of vacuum chamber modules connected together end-to-end and each said module has a respective access door.
13. An apparatus according to any one of claims 1-12, further comprising microwave shields (70) in the vacuum chamber between adjacent access doors.

14. An apparatus according to any one of claims 1-13, wherein the dehydration apparatus further comprises an emptying station for emptying the tray of dehydrated material, a washing station for washing the emptied tray and a filling station for filling the washed container with the organic material to be dehydrated.

15. An apparatus (200) for dehydrating organic material, comprising:

a vacuum chamber (202);

a vacuum chamber access door (80) covering an access port (84) into the vacuum chamber (202);

the access door having a plurality of magnetrons (86), each magnetron having a respective waveguide (90);

a microwave-transparent window (92) arranged between the waveguides and vacuum chamber;

the plurality of magnetrons and waveguides on the access door being arranged to radiate microwaves through the microwave-transparent window (92) into the vacuum chamber;

the waveguides being oriented to minimize microwave interference between the magnetrons on the access door; and

means (39, 46) for reducing pressure inside the vacuum chamber.

16. An apparatus according to claim 15, wherein each waveguide has an opening in a face of the access door (80), each opening being oriented at an angle different from the openings of the other waveguides on the access door.

17. An apparatus according to claim 15 or 16, further comprising a microwave chamber (94) between the magnetrons and the microwave-transparent window, the microwave chamber being adapted to be at atmospheric pressure.

18. A method for dehydrating an organic material, comprising the steps of:

reducing pressure in a vacuum chamber to a pressure less than atmospheric;

introducing the organic material to be dehydrated into the vacuum chamber;

moving the organic material through the vacuum chamber from an input end to a discharge end while applying microwave radiation from magnetrons positioned on a plurality of access doors of the vacuum chamber through a respective microwave-transparent window into the vacuum chamber to dehydrate the organic material, each magnetron having a respective waveguide, the waveguides on a respective access door being oriented to minimize microwave interference between the magnetrons on said access door; and

removing the dehydrated organic material from the vacuum chamber.

19. A method according to claim 18, wherein the microwave radiation from the magnetrons passes through a microwave chamber at atmospheric pressure before passing through the microwave-transparent window into the vacuum chamber.

20. A method for dehydrating an organic material, comprising the steps of:

introducing the organic material (96) to be dehydrated into a vacuum chamber (200);

reducing pressure in the vacuum chamber to a pressure less than atmospheric;

applying microwave radiation from a plurality of magnetrons (86) positioned on an access door (80) of the vacuum chamber through a microwave-transparent window (92) into the vacuum chamber to dehydrate the organic material, each magnetron having a respective waveguide (90), the waveguides being oriented to minimize microwave interference between the magnetrons; and

removing the dehydrated organic material from the vacuum chamber.

21. A method according to claim 21, wherein the microwave radiation from the magnetrons passes through a microwave chamber at atmospheric pressure before passing through the microwave-transparent window into the vacuum chamber.

2/4

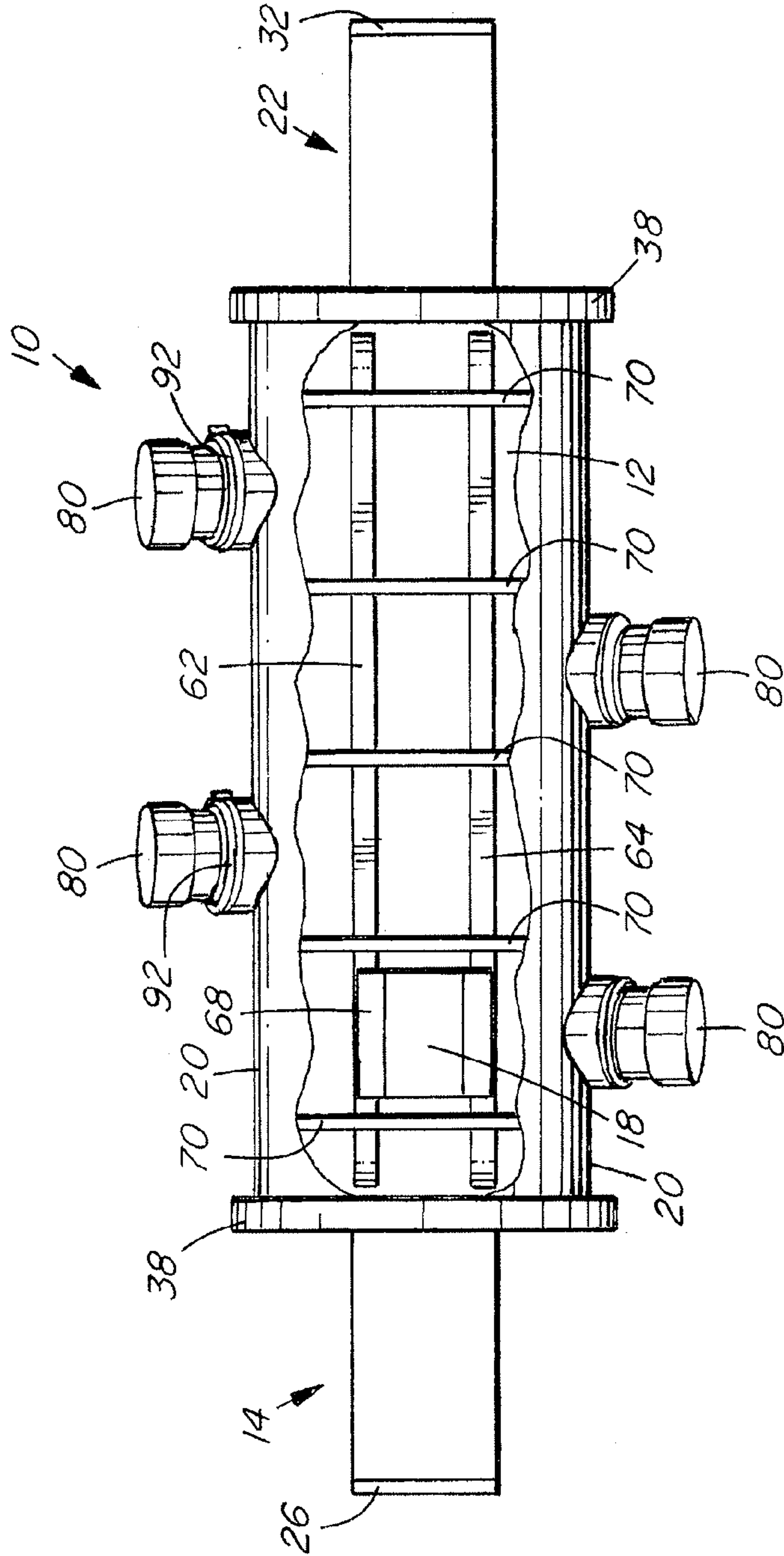

FIG. 2

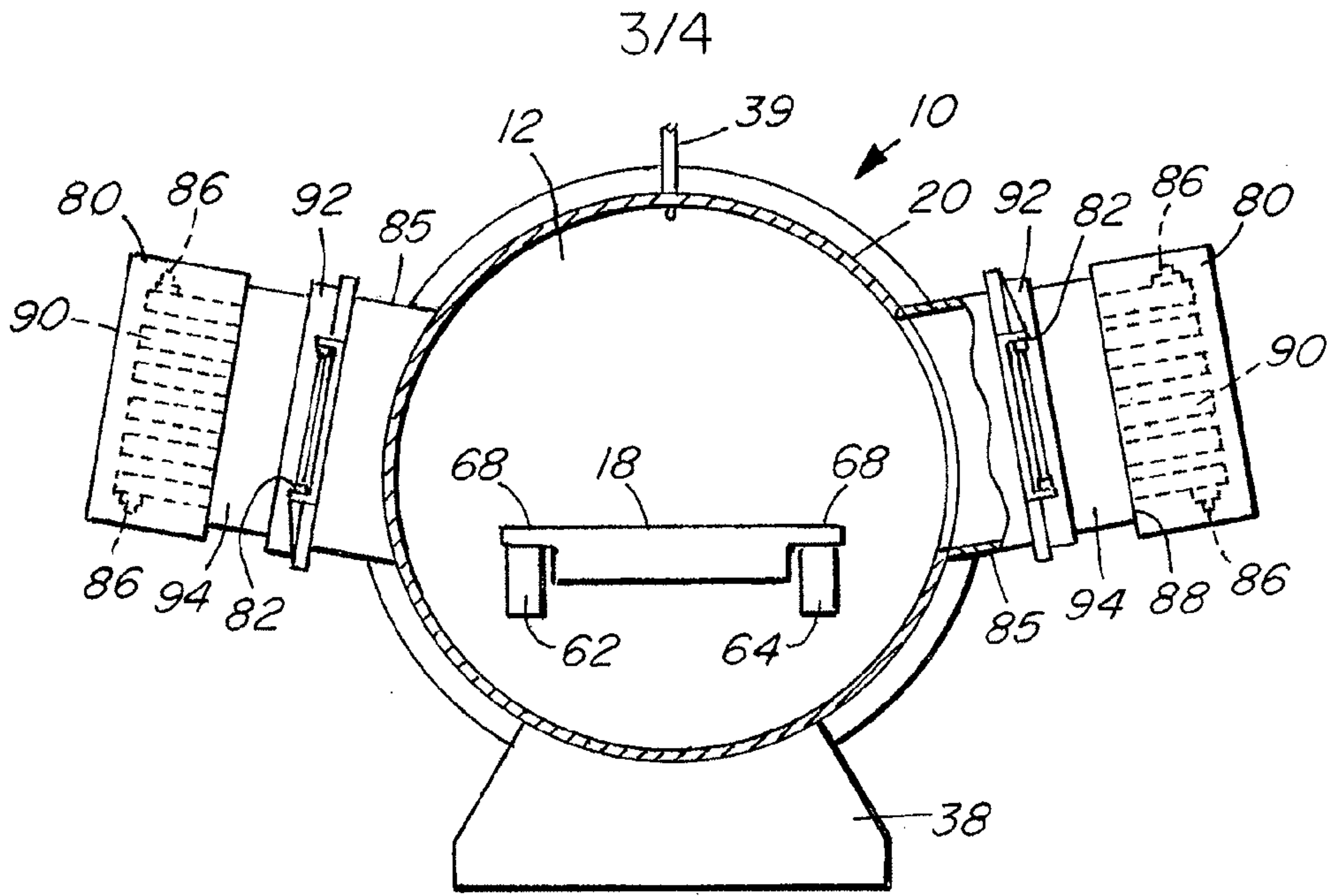

FIG. 3

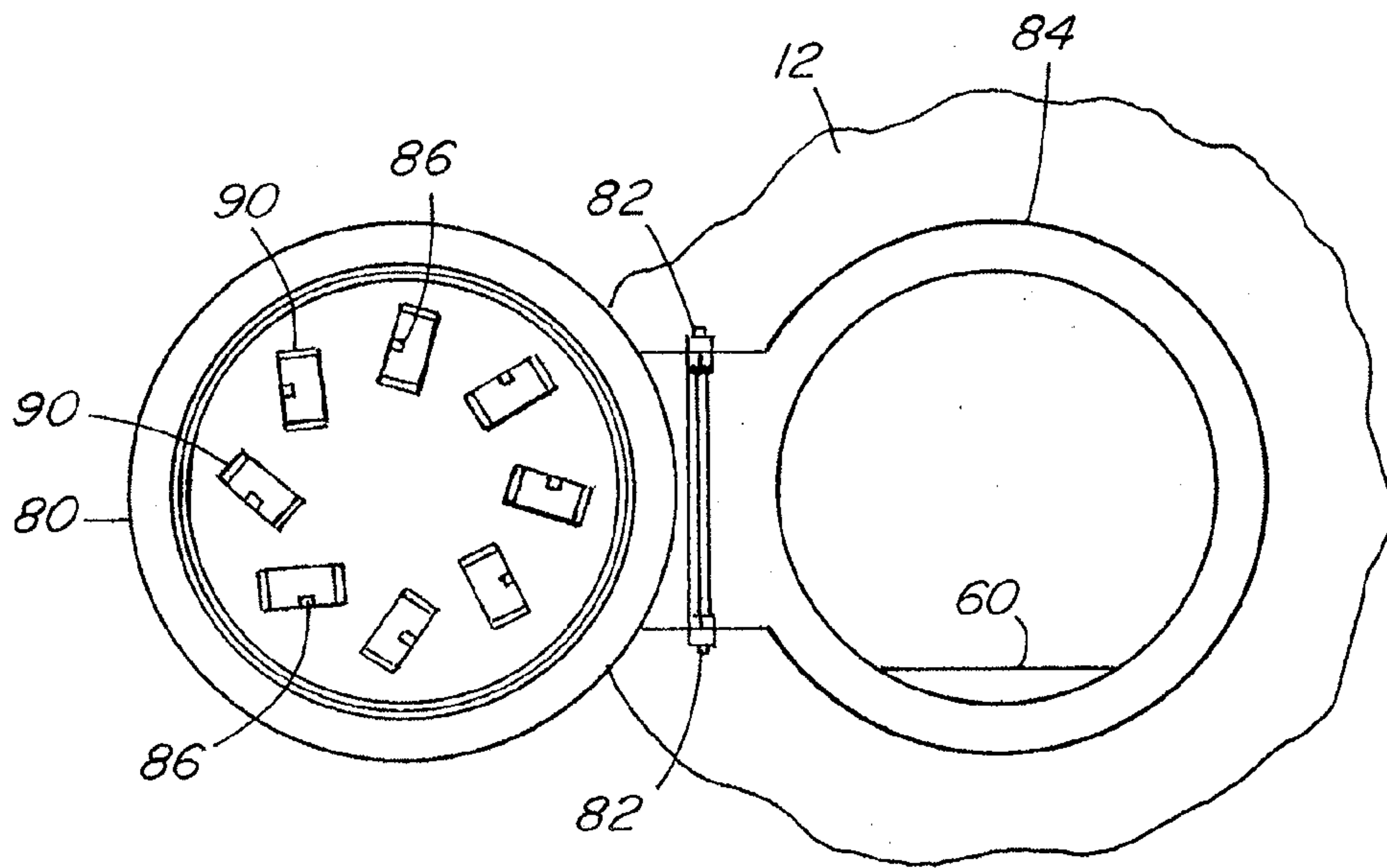

FIG. 4

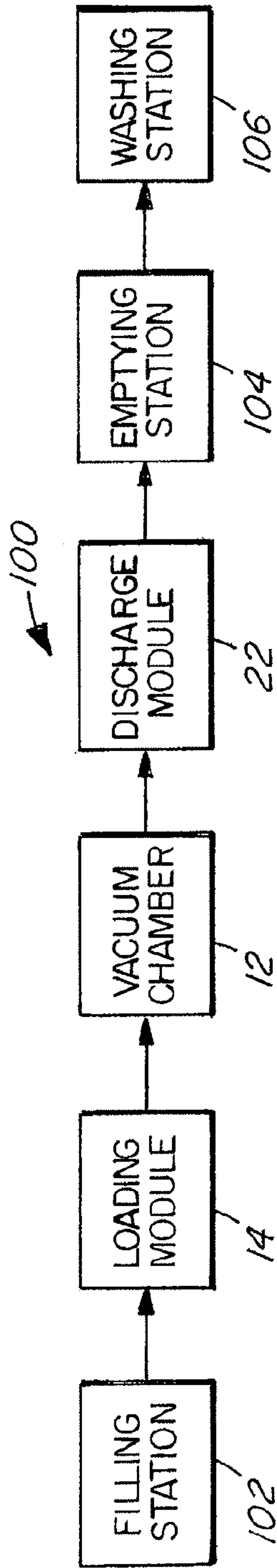

FIG. 5

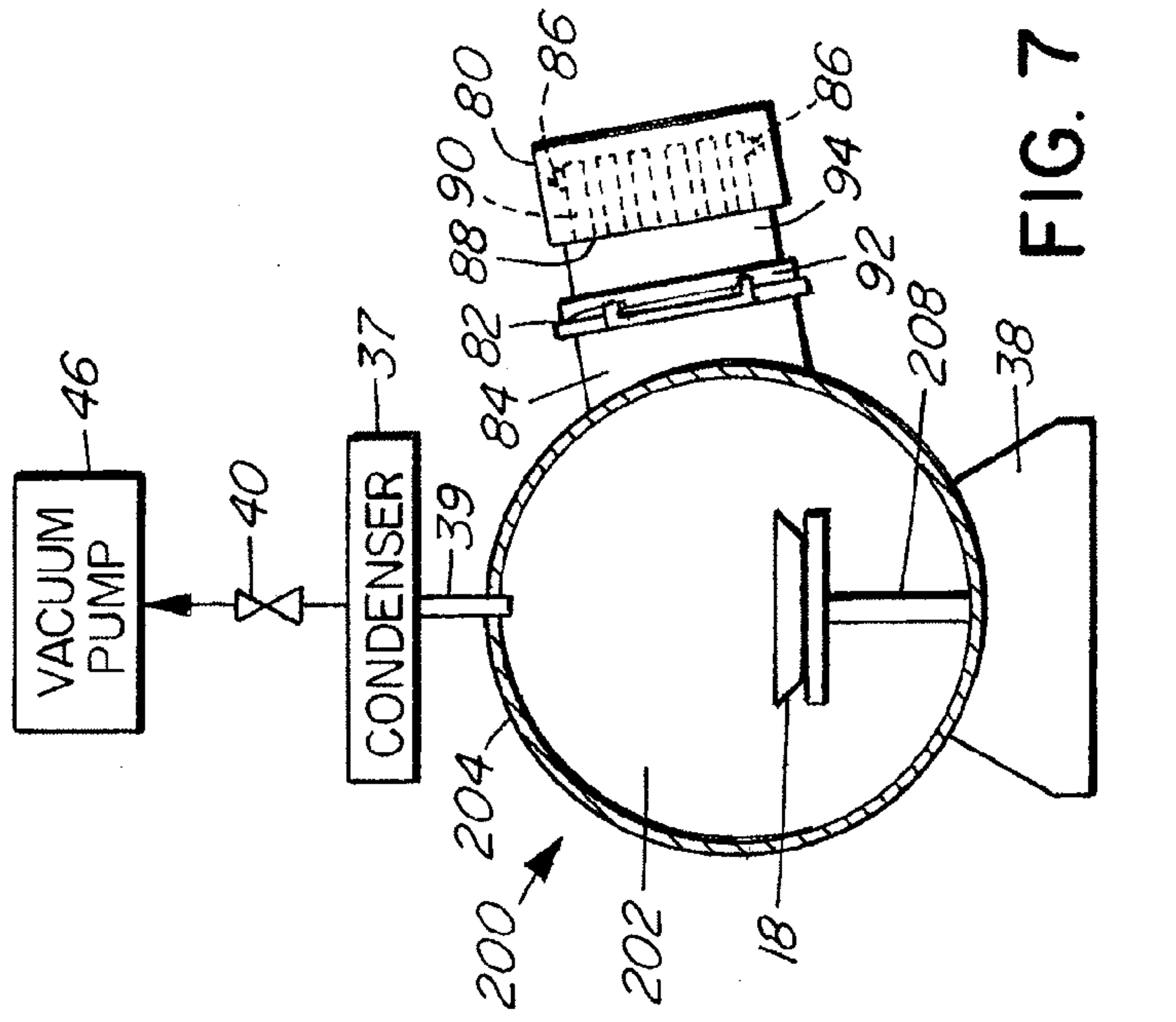

FIG. 7

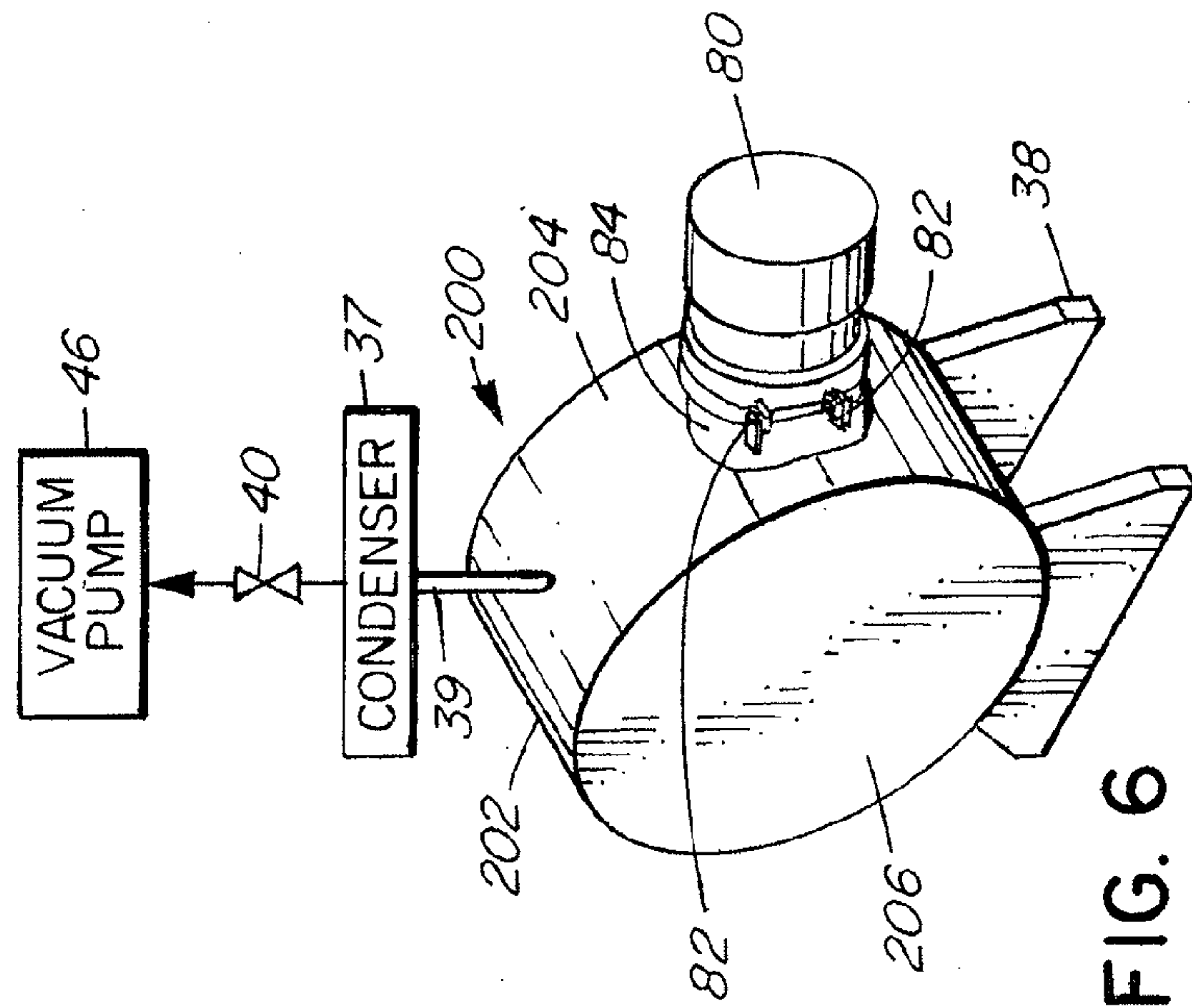

FIG. 6

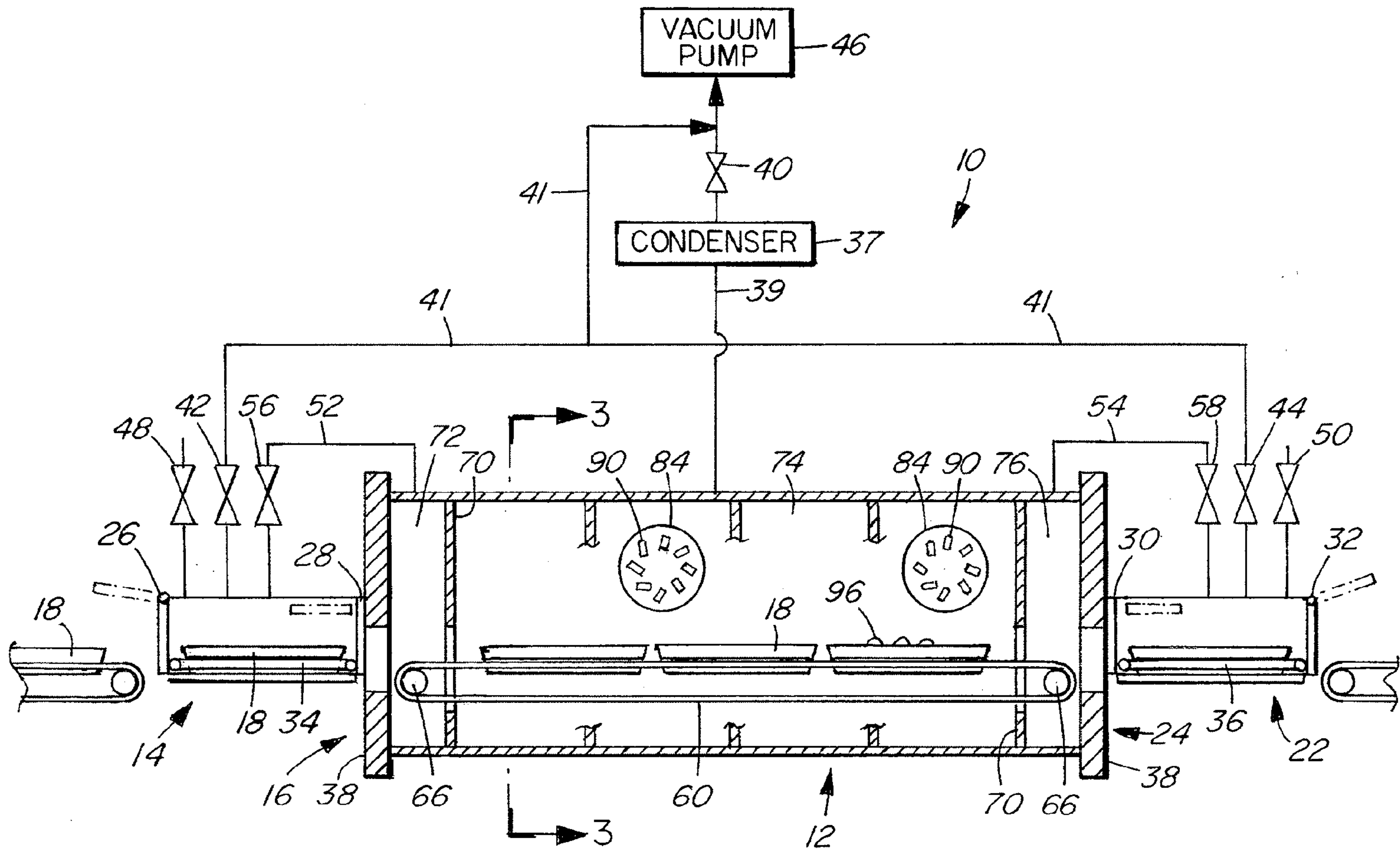

FIG. 1