



US 20050155316A1

(19) **United States**

(12) **Patent Application Publication**
Shipley

(10) **Pub. No.: US 2005/0155316 A1**

(43) **Pub. Date: Jul. 21, 2005**

(54) **METHOD AND SYSTEM FOR
EMBELLISHING ARCHITECTURAL
STRUCTURES**

Publication Classification

(51) **Int. Cl.⁷ E04C 1/00; E04B 1/00**

(52) **U.S. Cl. 52/741.1**

(76) **Inventor: Sam L. Shipley, Arlington, TX (US)**

Correspondence Address:
**LAW OFFICES OF ERIC KARICH
2807 ST. MARK DR.
MANSFIELD, TX 76063 (US)**

(57) **ABSTRACT**

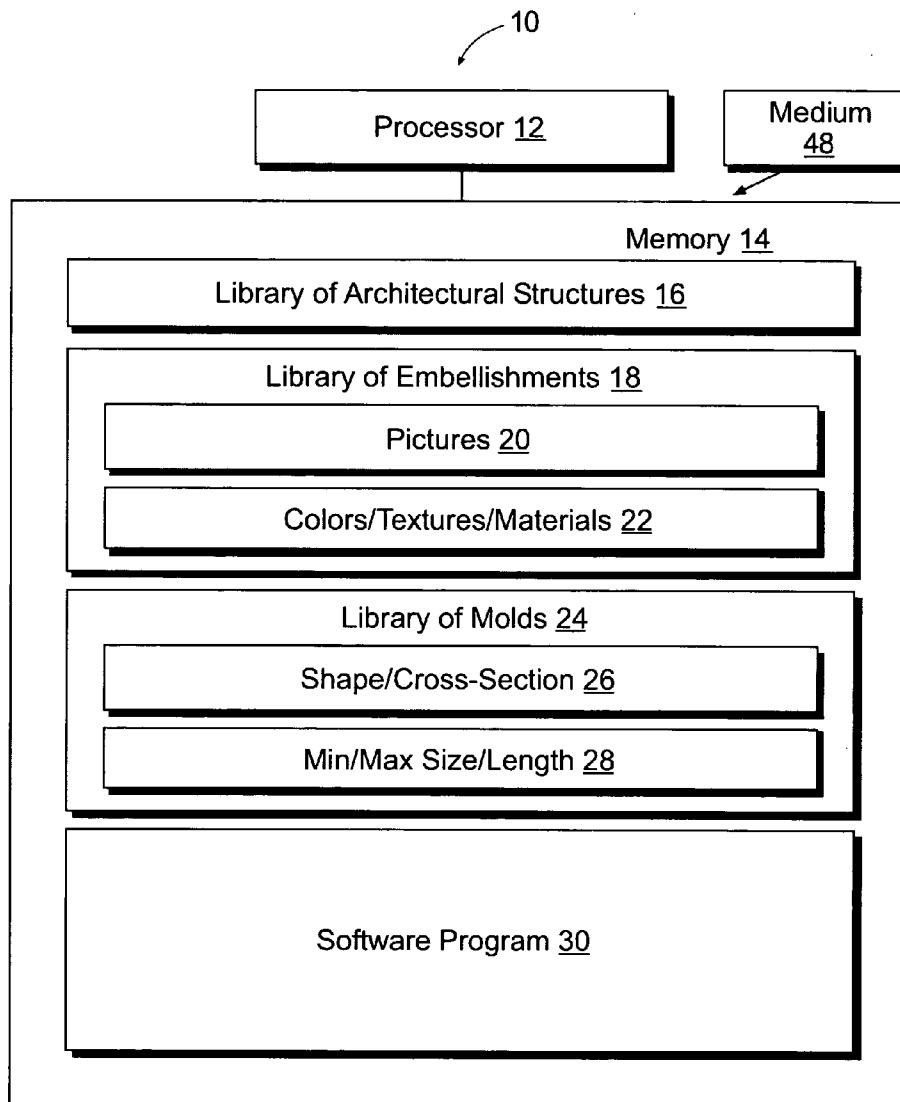
A method is disclosed for embellishing an architectural structure. Information is first received indicative of a dimension of the architectural structure and the selected embellishment of the architectural structure along the dimension. A mold is selected from a library of molds to construct the selected embellishment. The dimension of the architectural structure and dimensional information of the selected mold are used to calculate a dimension of the selected embellishment. A described computer system is configured to carry out the method. A computer-readable medium is disclosed including program instructions for carrying out the method.

(21) **Appl. No.: 10/811,021**

(22) **Filed: Mar. 25, 2004**

Related U.S. Application Data

(60) **Provisional application No. 60/537,589, filed on Jan. 20, 2004.**



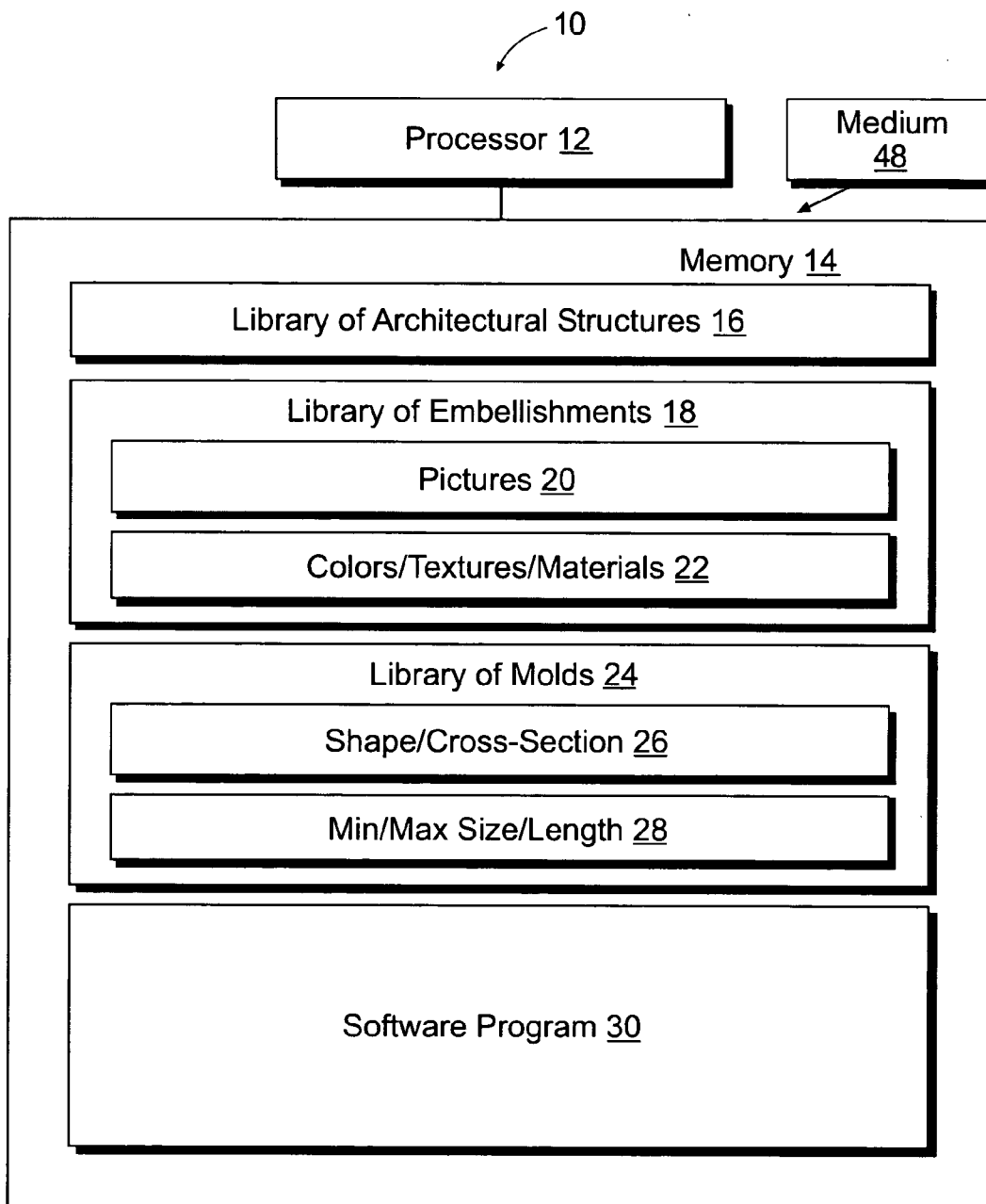


Fig. 1A

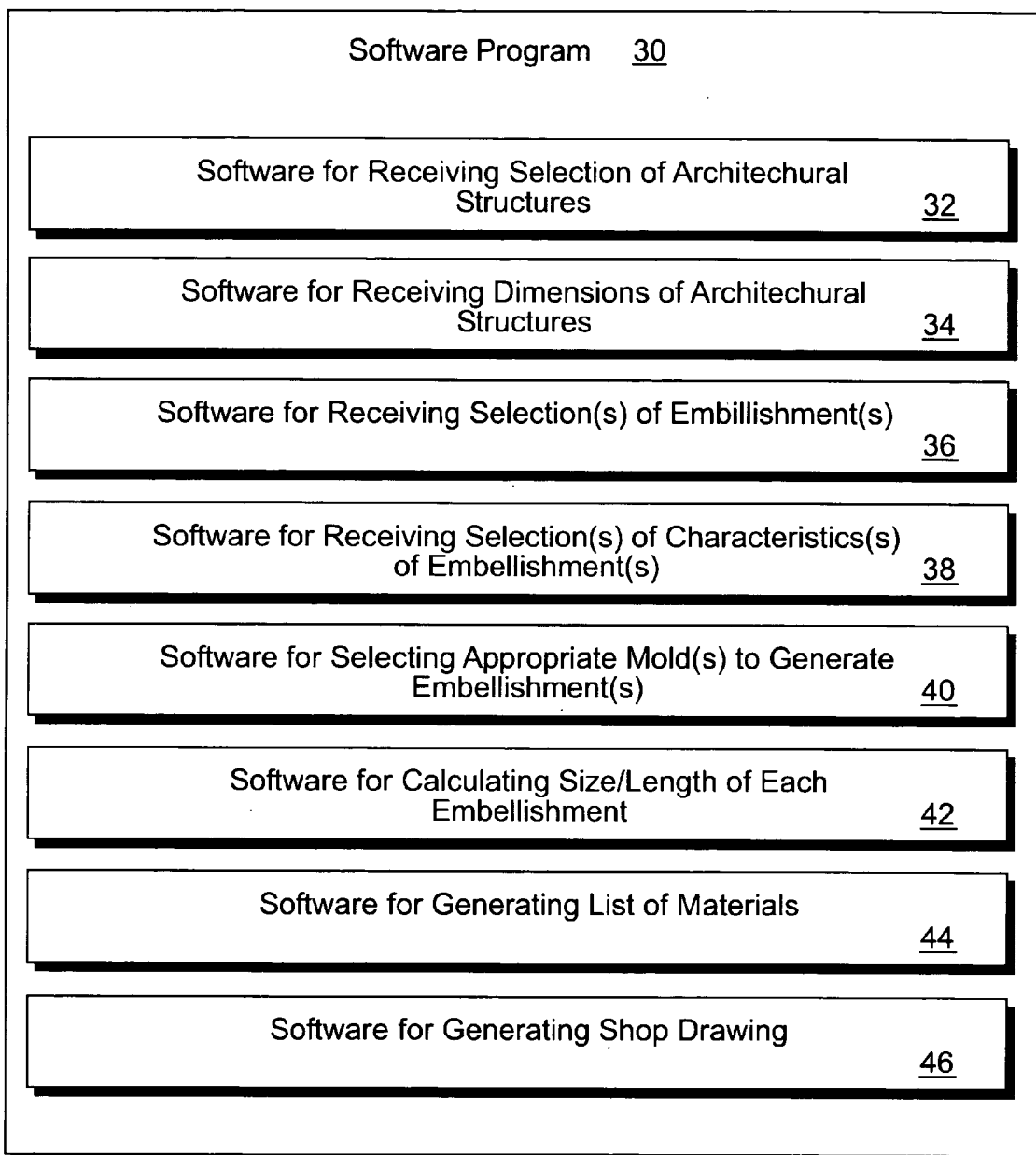


Fig. 1B

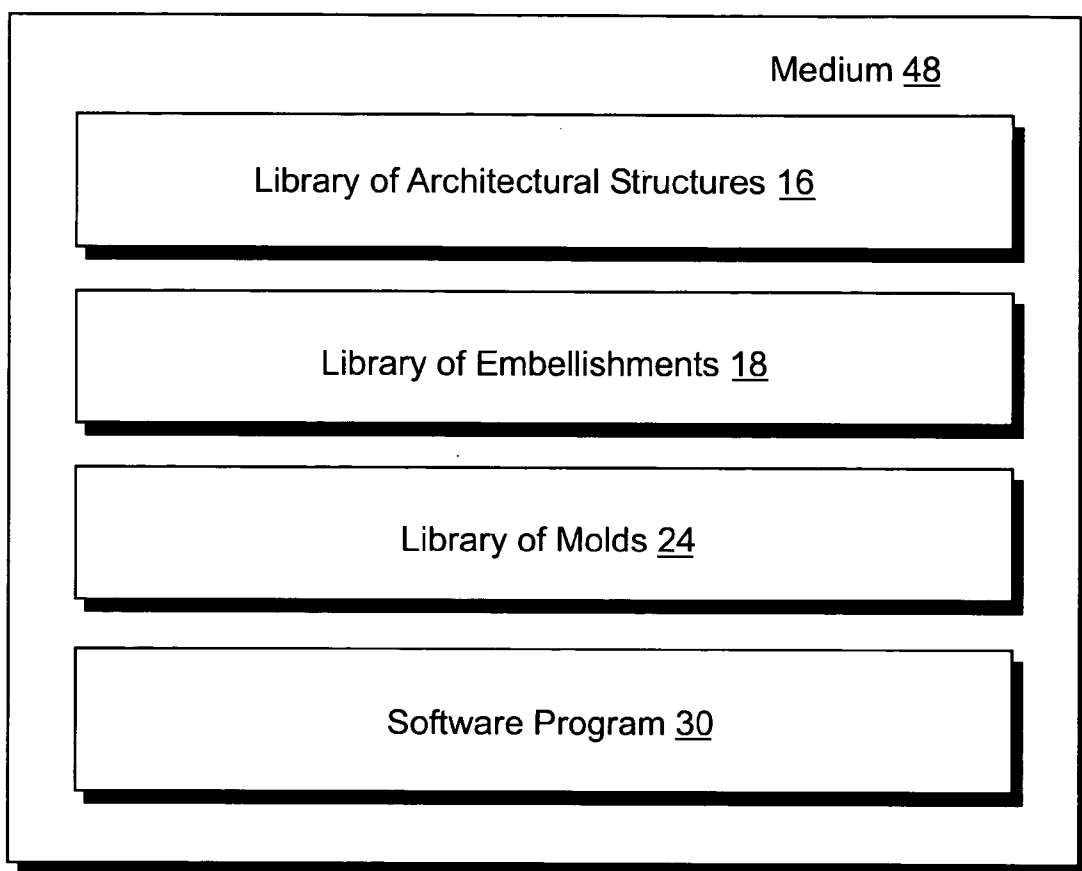


Fig. 1C

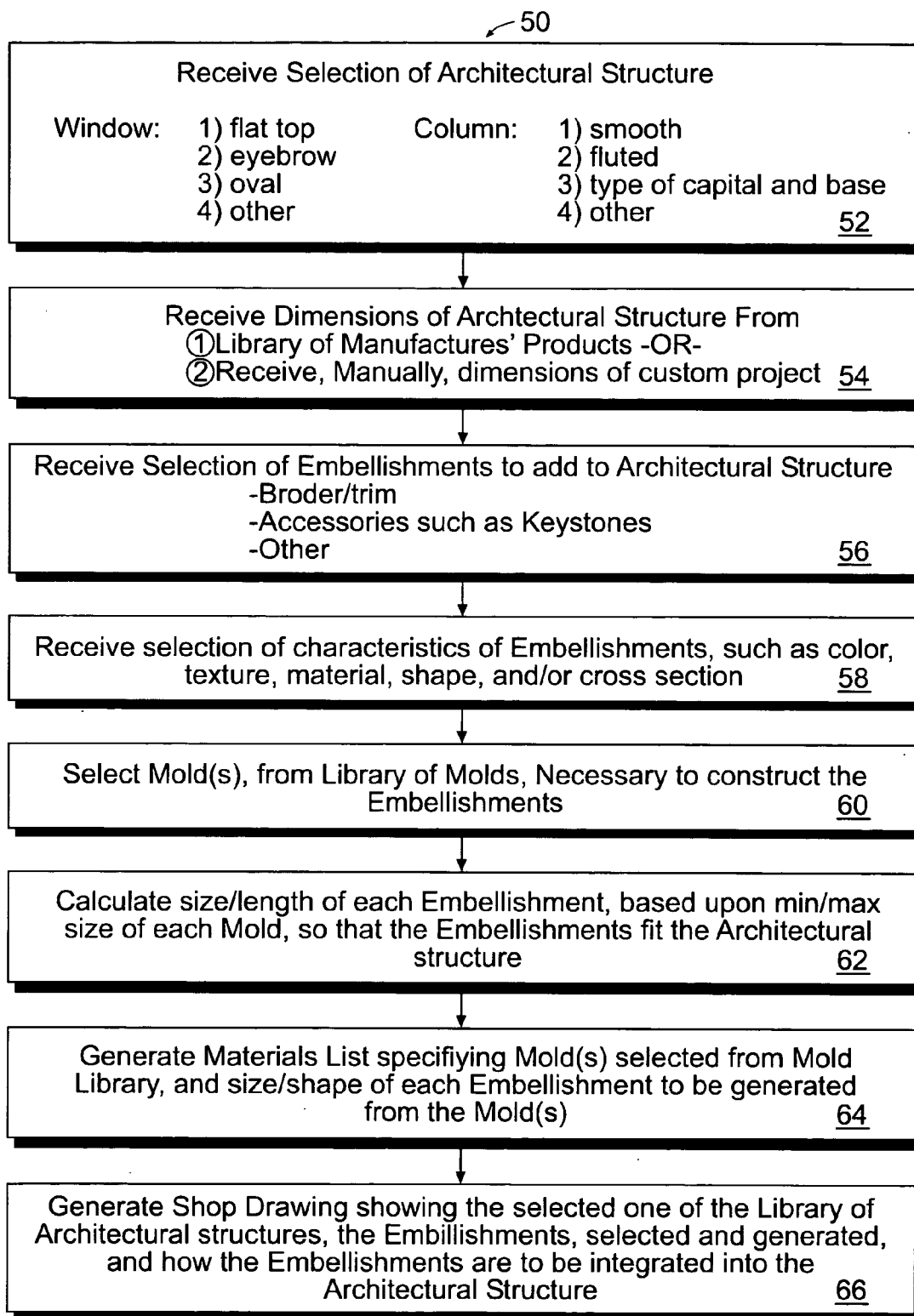


Fig. 2

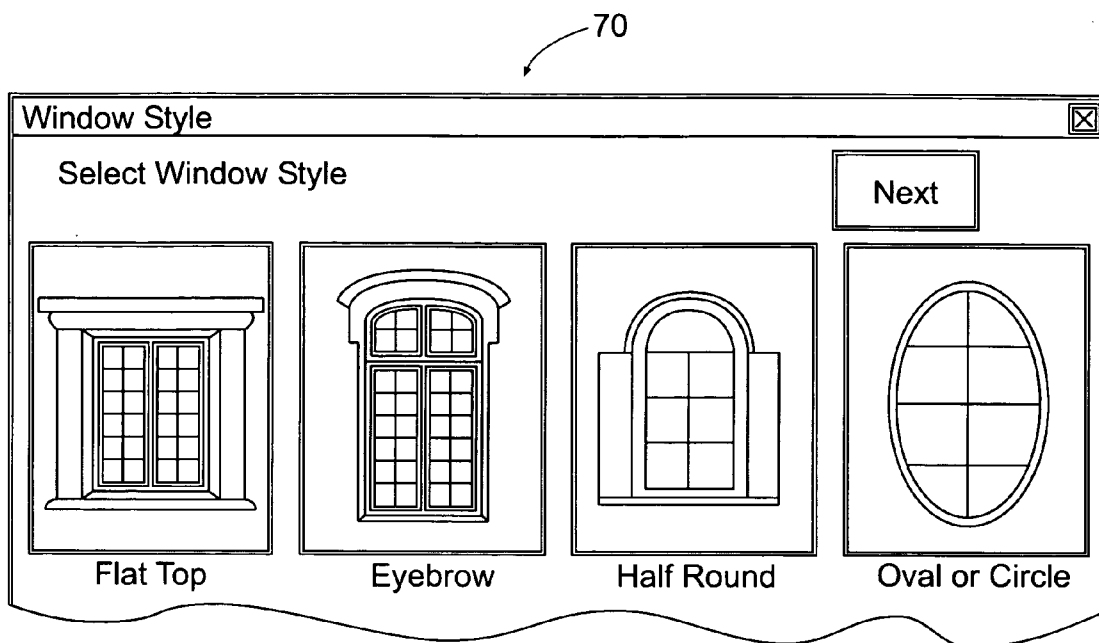


Fig. 3

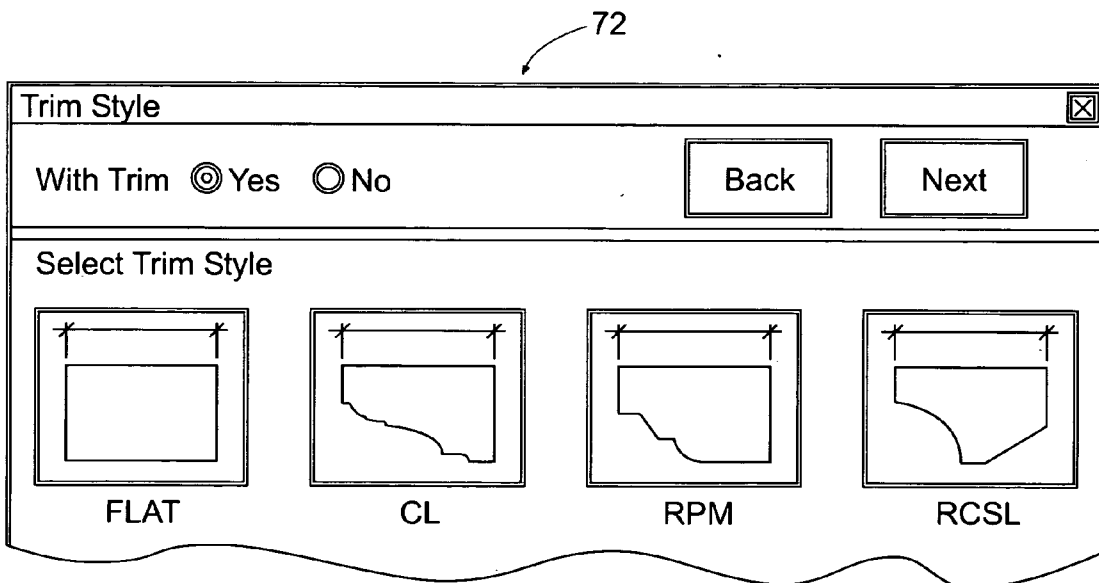


Fig. 4

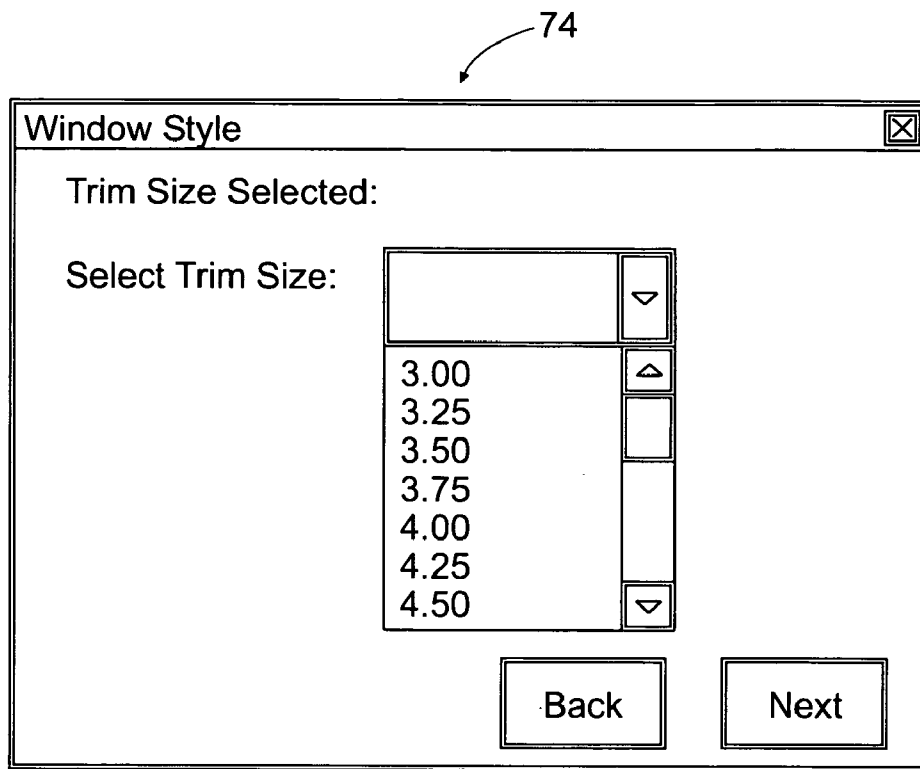


Fig. 5

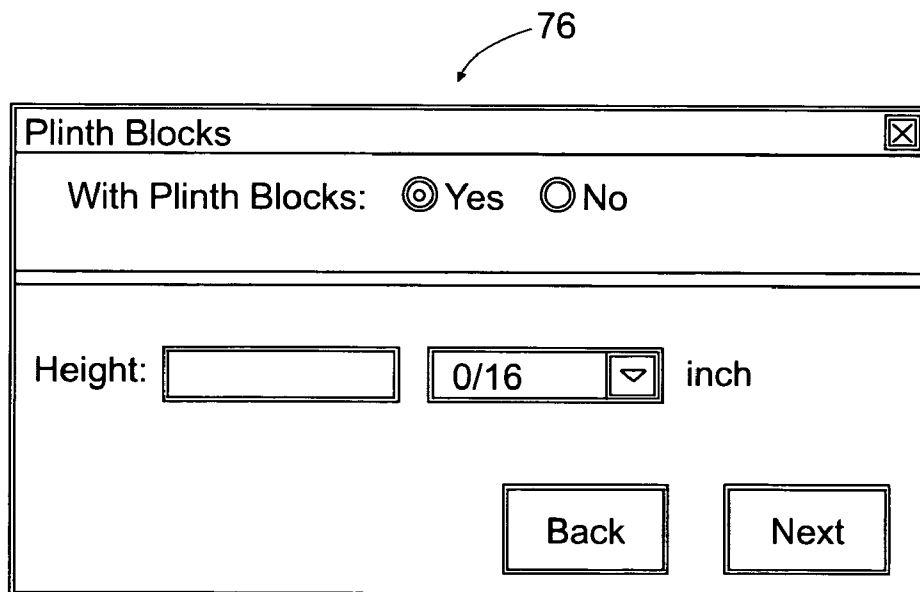


Fig. 6

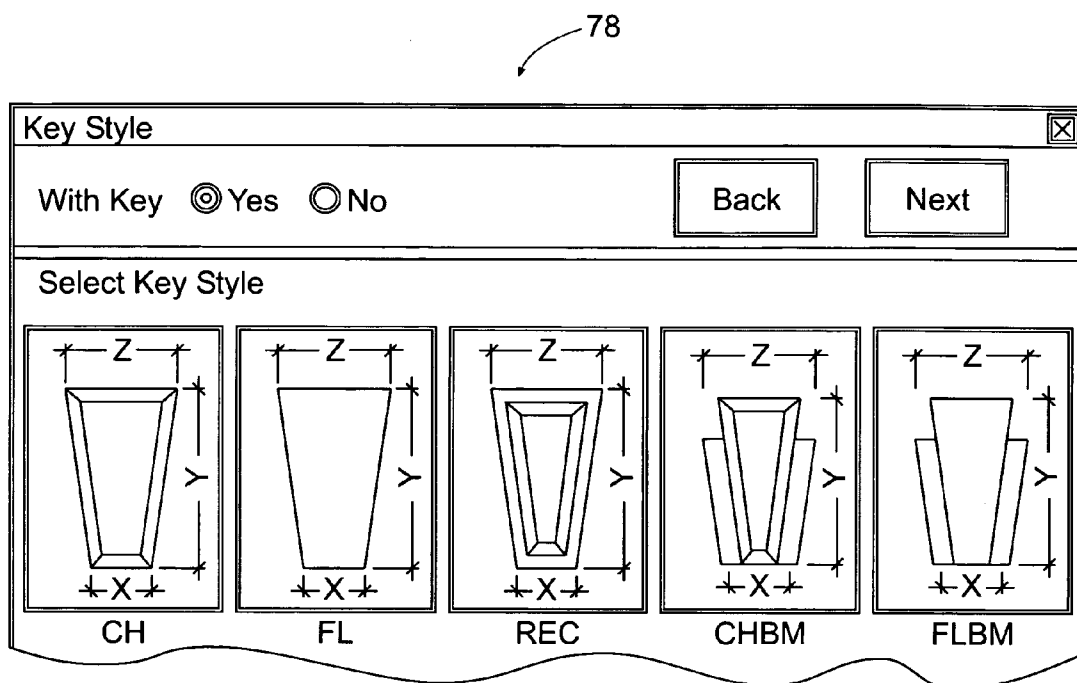


Fig. 7

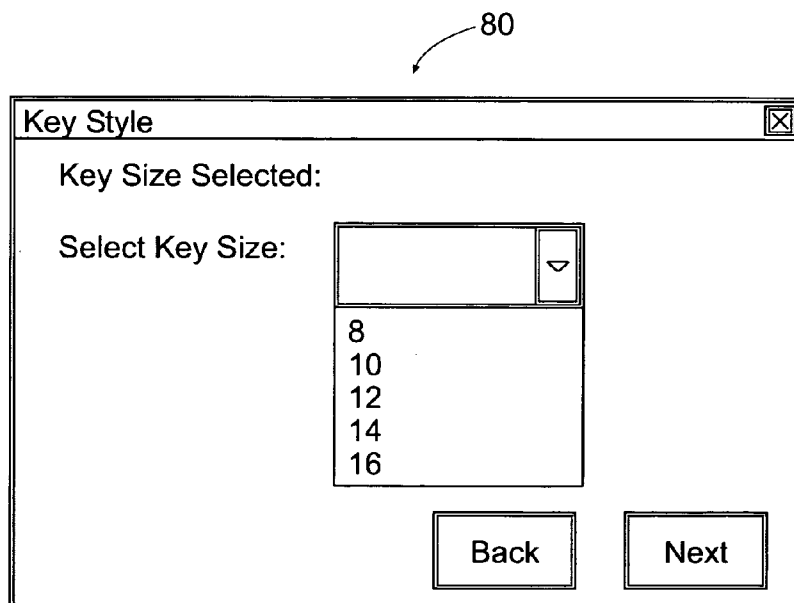


Fig. 8

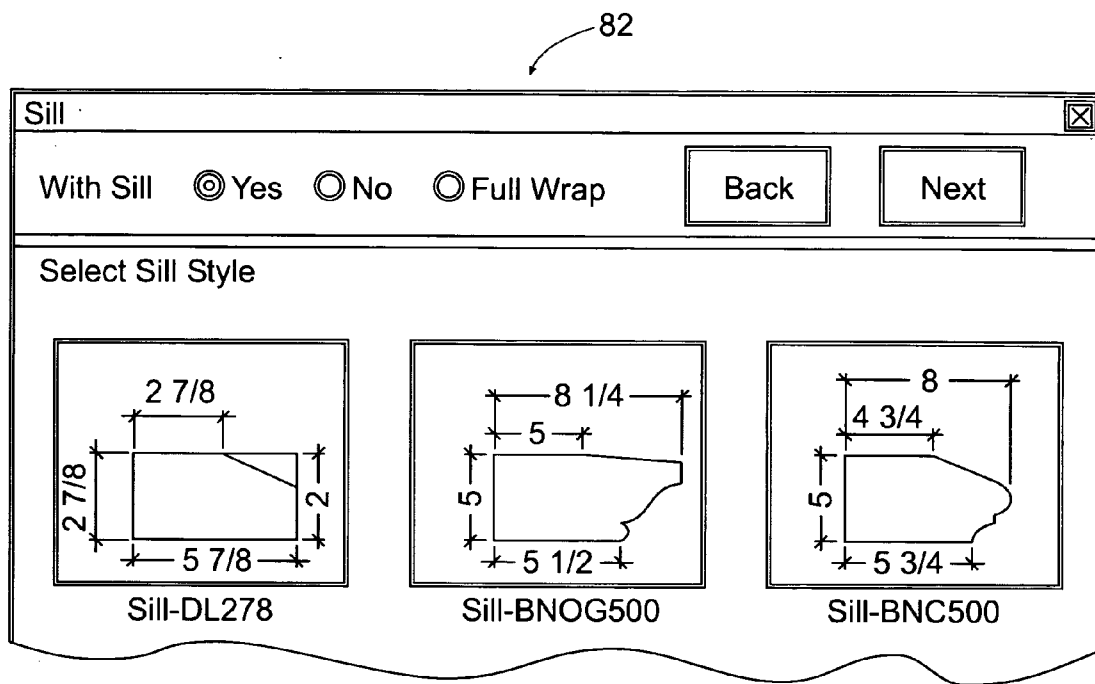


Fig. 9

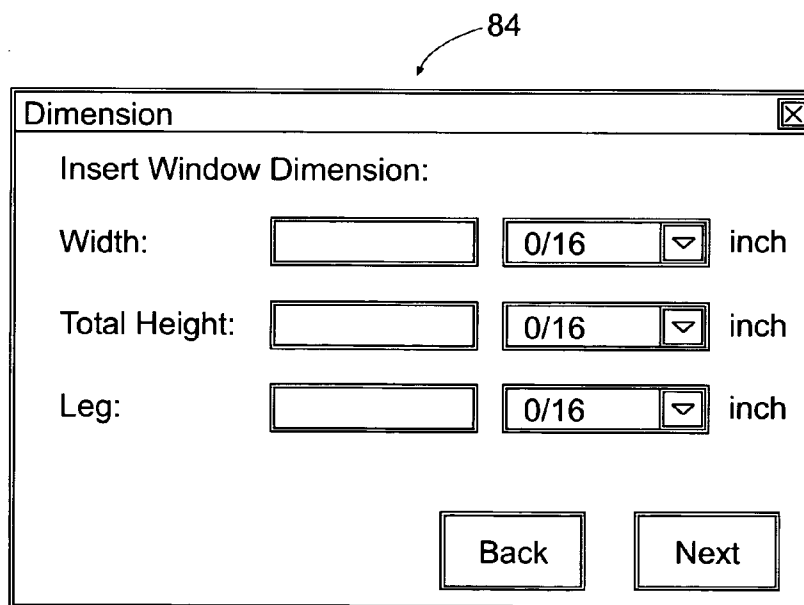


Fig. 10

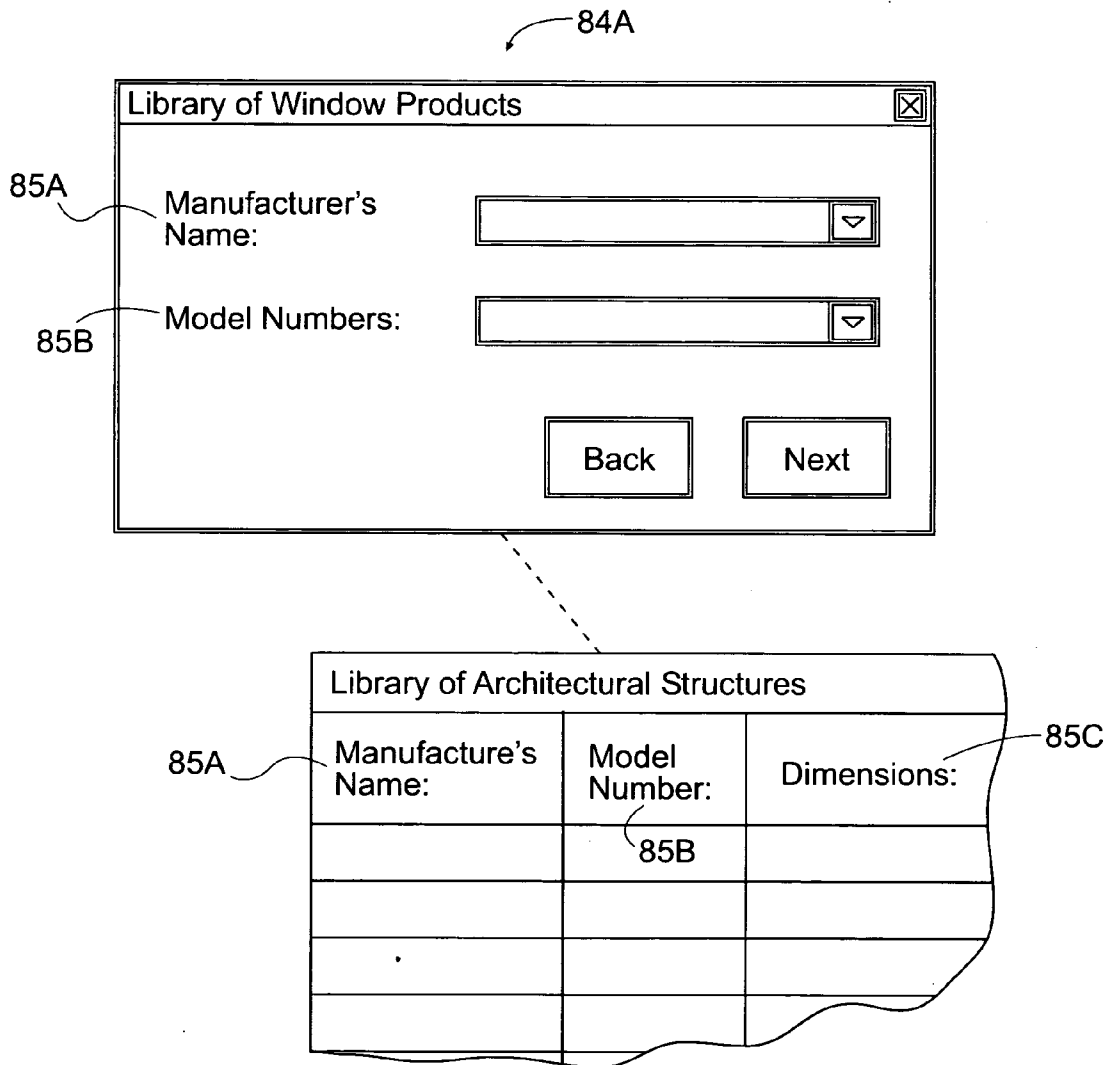


Fig. 10A

86

The image shows a software window titled "Quantity" with a close button in the top right corner. The window contains the following elements:

- Insert Window Quantity:** A label at the top of the form.
- Quantity:** A text input field containing the number "1".
- Color:** A dropdown menu with "Unspecified" selected.
- Finish:** A dropdown menu with "Smooth" selected. A list of options is visible below the menu:
 - Smooth
 - Light Pitted Distressed
 - Heavy Pitted Distressed
 - Light Acid Wash
 - Heavy Acid Wash
 - Sand Blasted
 - Antiqued
- Install:** A checkbox that is currently unchecked.
- Construction:** A checkbox that is currently unchecked.
- Navigation:** Two buttons at the bottom: "Back" and "Next".

Fig. 11

88

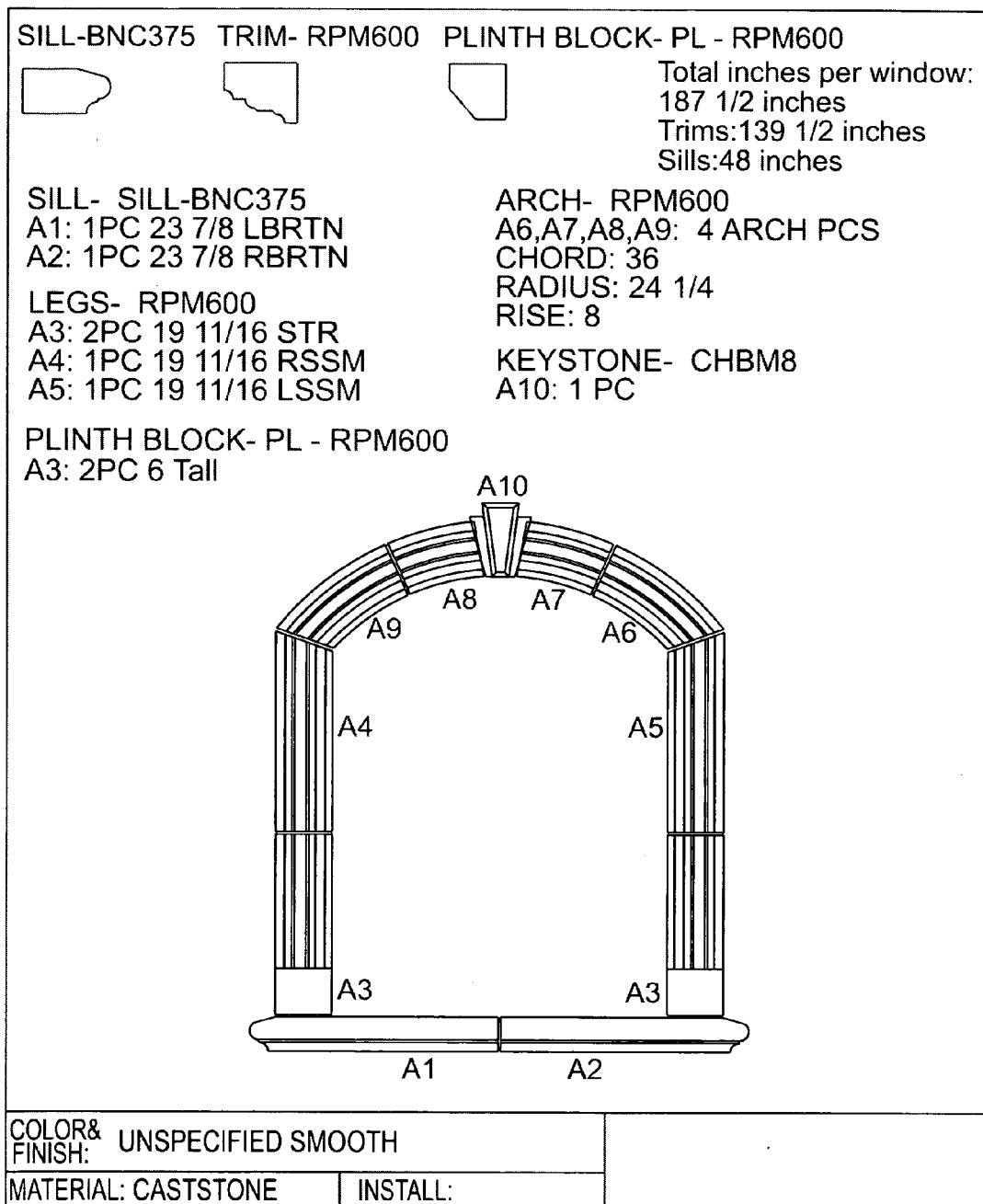


Fig. 12

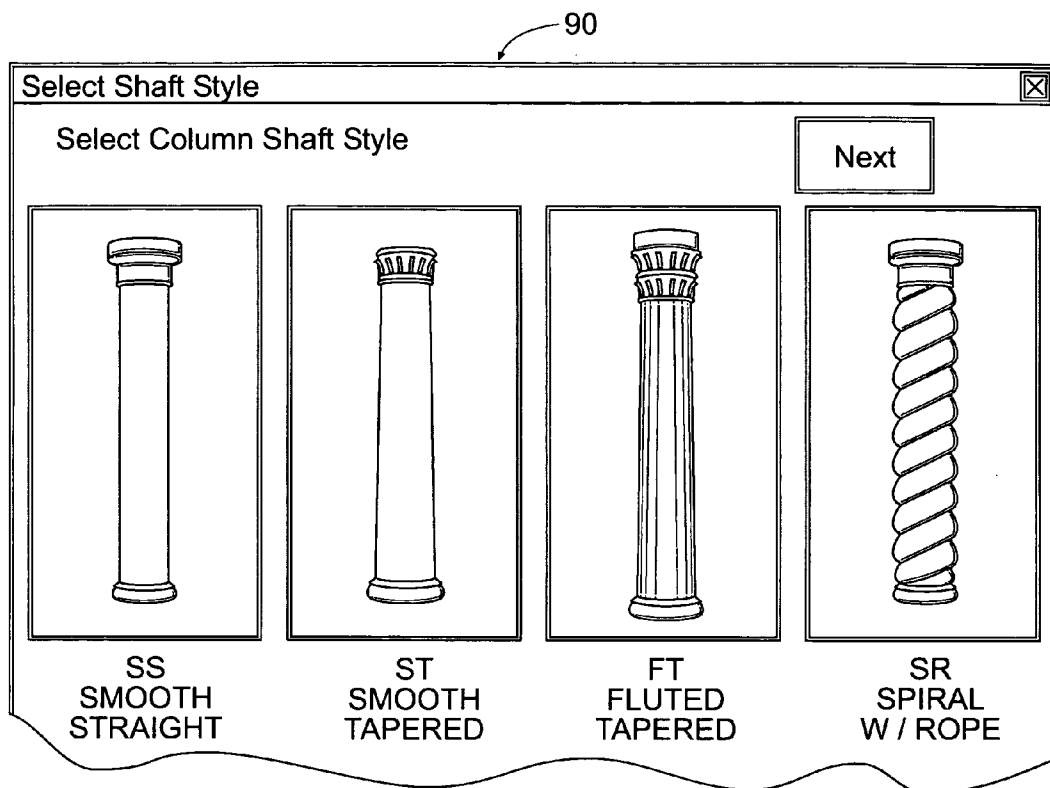


Fig. 13

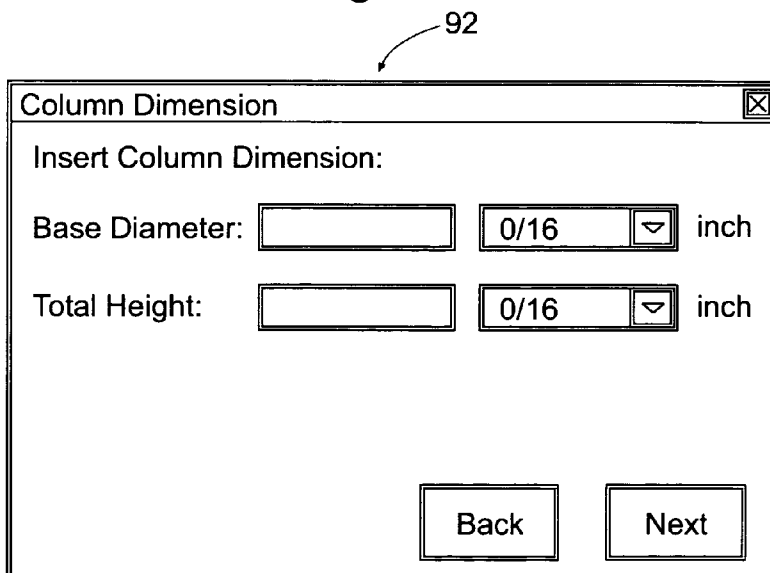


Fig. 14

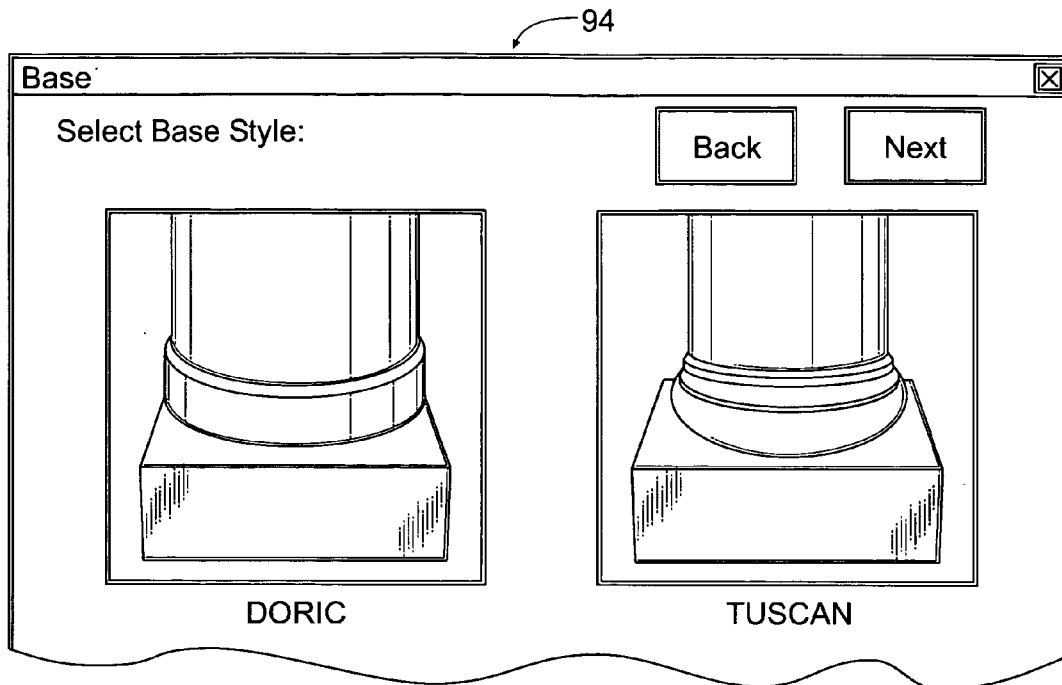


Fig. 15

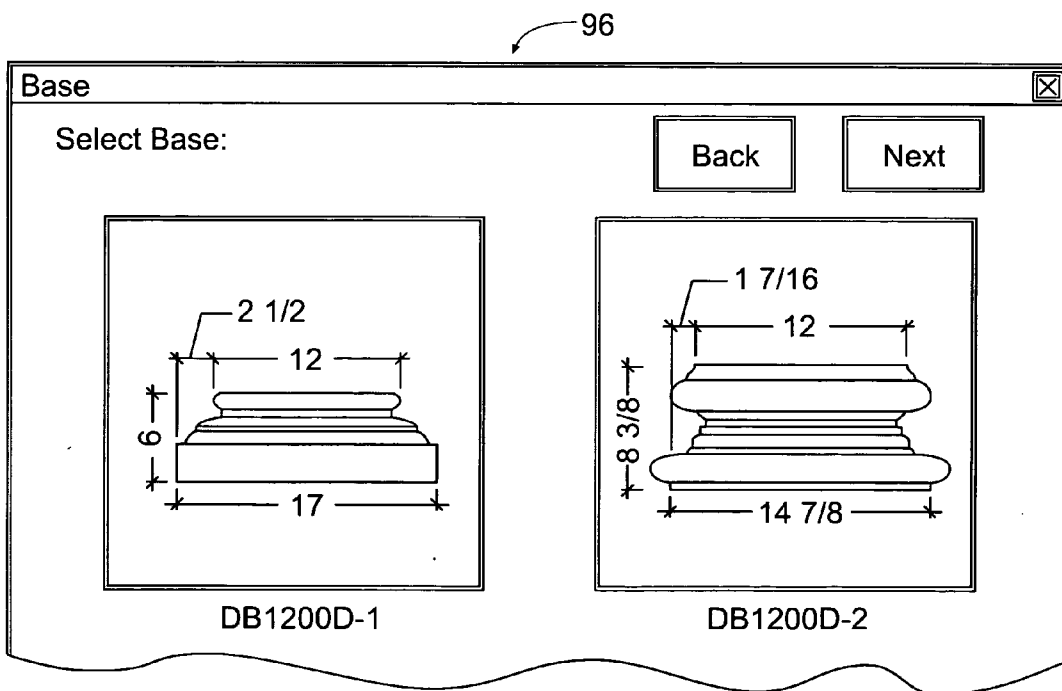


Fig. 16

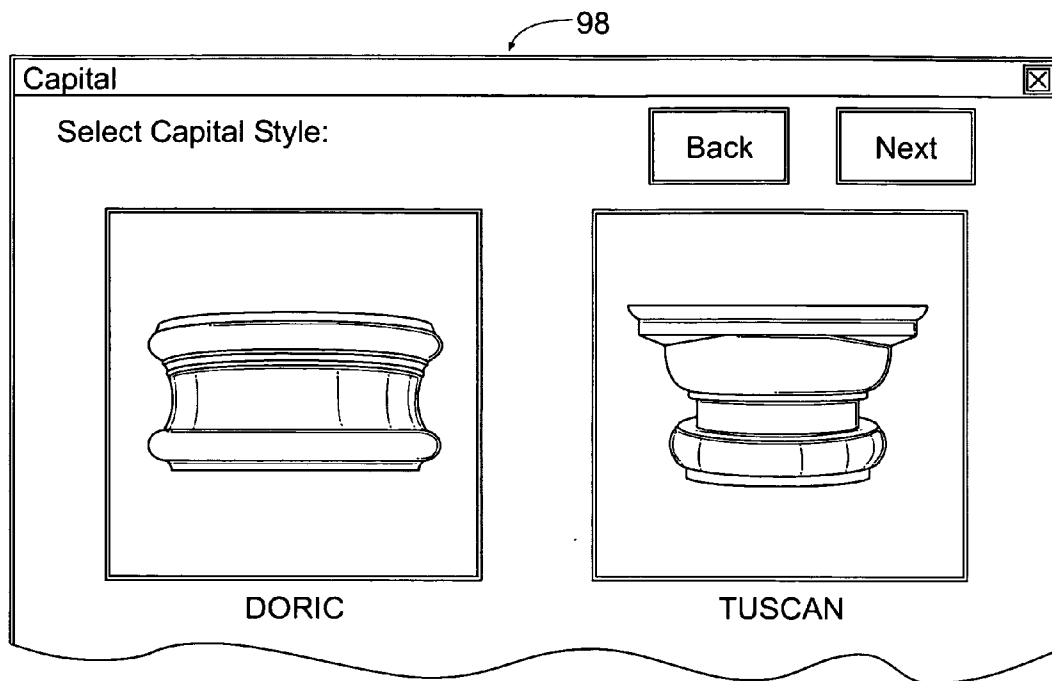


Fig. 17

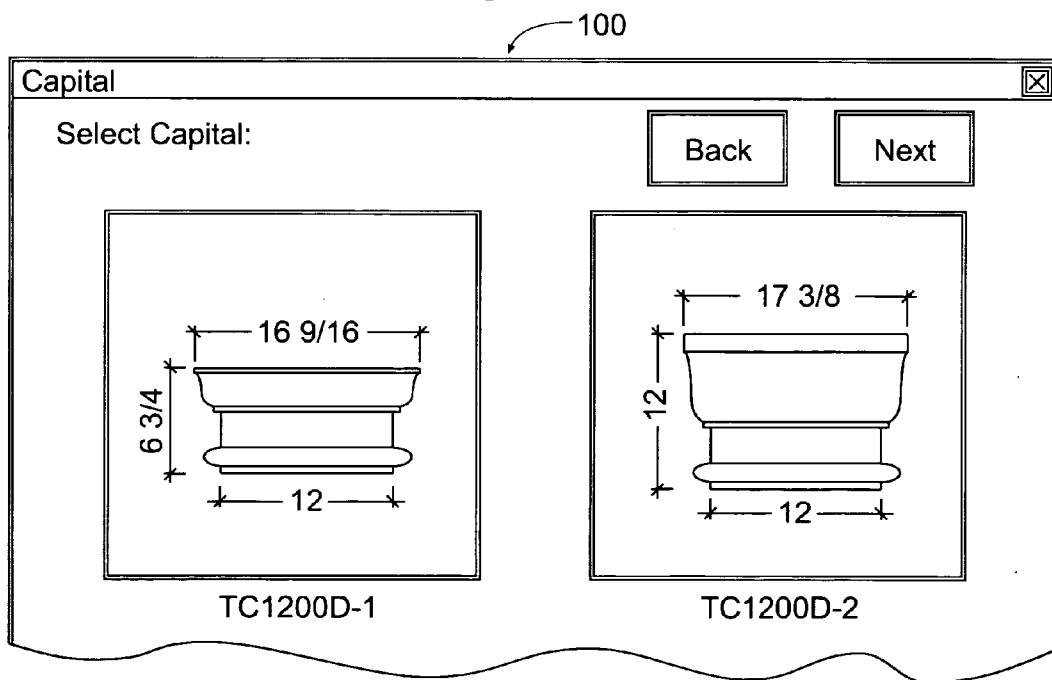


Fig. 18

102

The dialog box is titled "Quantity" and contains the following fields and options:

- Insert Column Quantity:**
 - Quantity:** A text input field containing the number "1".
 - Type:** A dropdown menu with "FULL" selected.
 - With Flat Base:** A dropdown menu with "Yes" selected.
 - Flat Base Height:** A text input field followed by a dropdown menu showing "0/16" and the unit "inch".
 - Color:** A dropdown menu with "Unspecified" selected.
 - Material:** A dropdown menu with "CASTSTONE" selected.
 - Finish:** A dropdown menu with "Smooth" selected.
 - Install:** A dropdown menu with a list of options: "Smooth", "Light Pitted Distressed", "Heavy Pitted Distressed", "Light Acid Wash", "Heavy Acid Wash", "Sand Blasted", and "Antiqued".

At the bottom of the dialog box are two buttons: "Back" and "Next".

Fig. 19

104

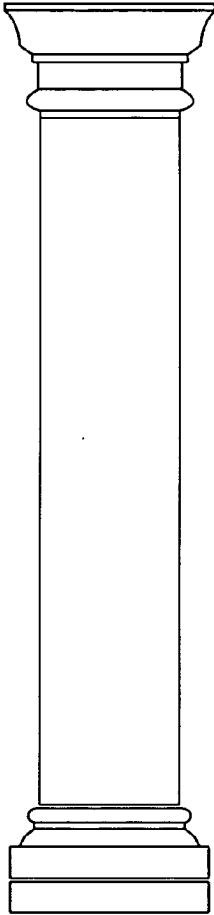
		<p>COLUMN</p> <p>TUSCAN CAPITAL: TC1200D-2 2 HALVES 12 DIAM X 6 3/4 TALL</p> <p>SMOOTH STRAIGHT BASE SHAFT: SS1200 2 HALVES</p> <p>DORIC BASE: DB1200d-1 2 HALVES 12 DIAM X 6 TALL X 17 BM</p> <p>Flat Base 2 HALVES 17 LONG X 8 3/8 WIDE X 4 TALL</p> <p>CUSTOMER: COLOR: Unspecified QUANTITY: 1 TYPE: FULL MATERIAL: CASTSTONE</p>
<p>COLOR & FINISH: UNSPECIFIED SMOOTH</p>		
<p>MATERIAL: CASTSTONE</p>	<p>INSTALL:</p>	

Fig. 20

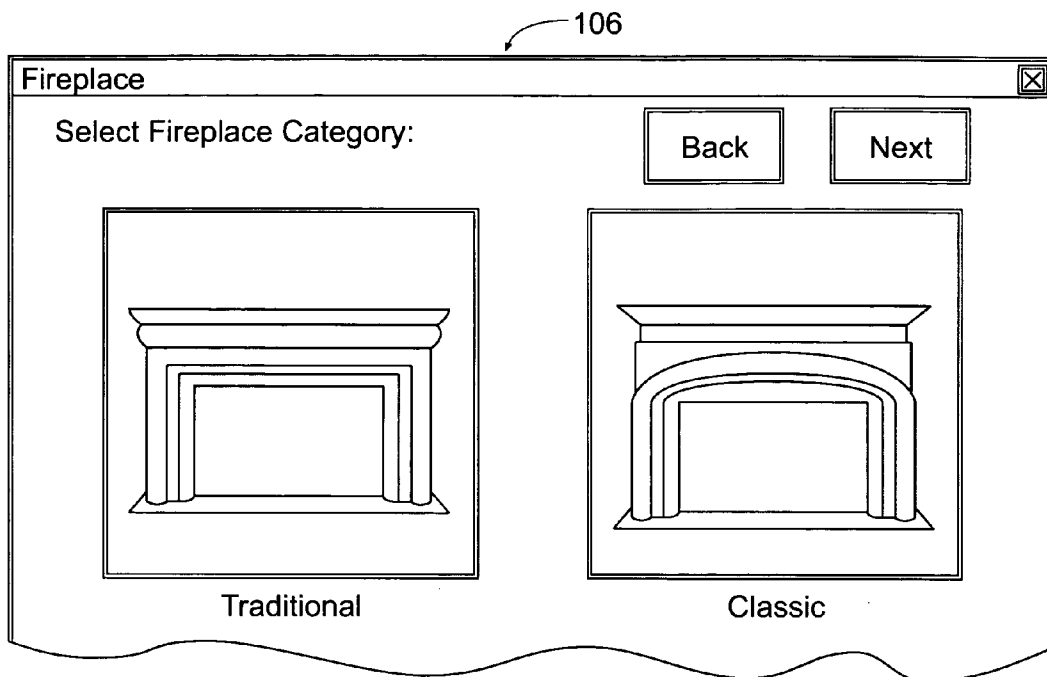


Fig. 21

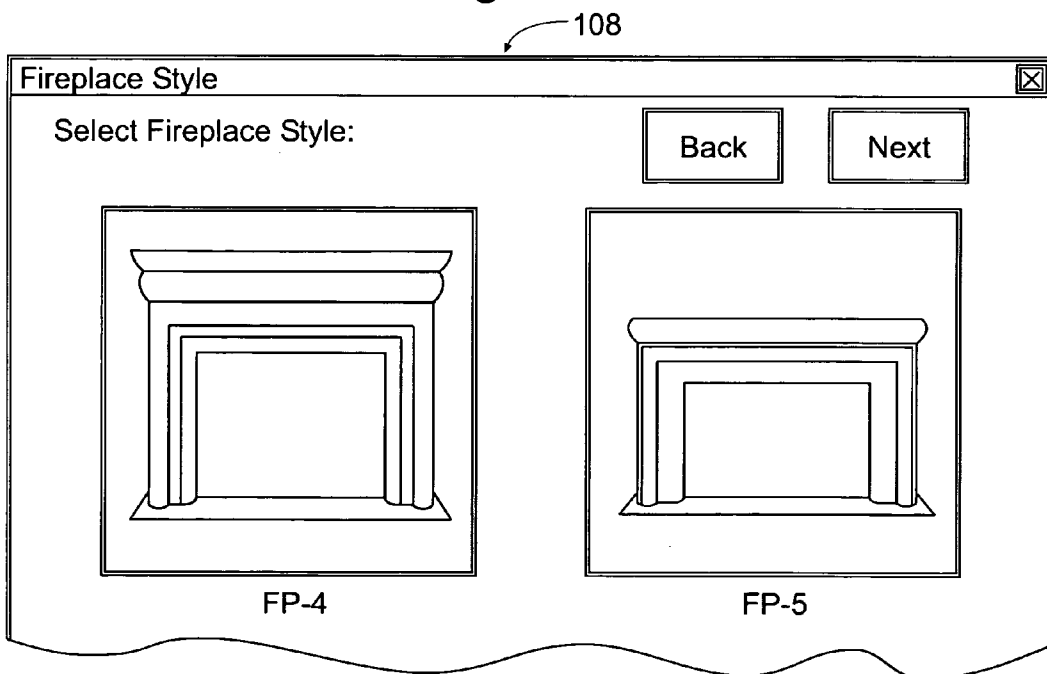


Fig. 22

110

Fire Box Dimension

Enter Fire Box Dimension:

Fire Box Width:
Adjustable to any Size

Fire Box Height:
Adjustable to any Size

Or Select a Standard Fire Place:

Part NO.	Box Width	Box Height
<input type="radio"/> FP-4A	36	40
<input type="radio"/> FP-4B	40	40
<input type="radio"/> FP-4C	42	40
<input type="radio"/> FP-4D	48	40
<input type="radio"/>		
<input type="radio"/>		
<input type="radio"/>		
<input type="radio"/>		
<input type="radio"/>		

Fig. 23

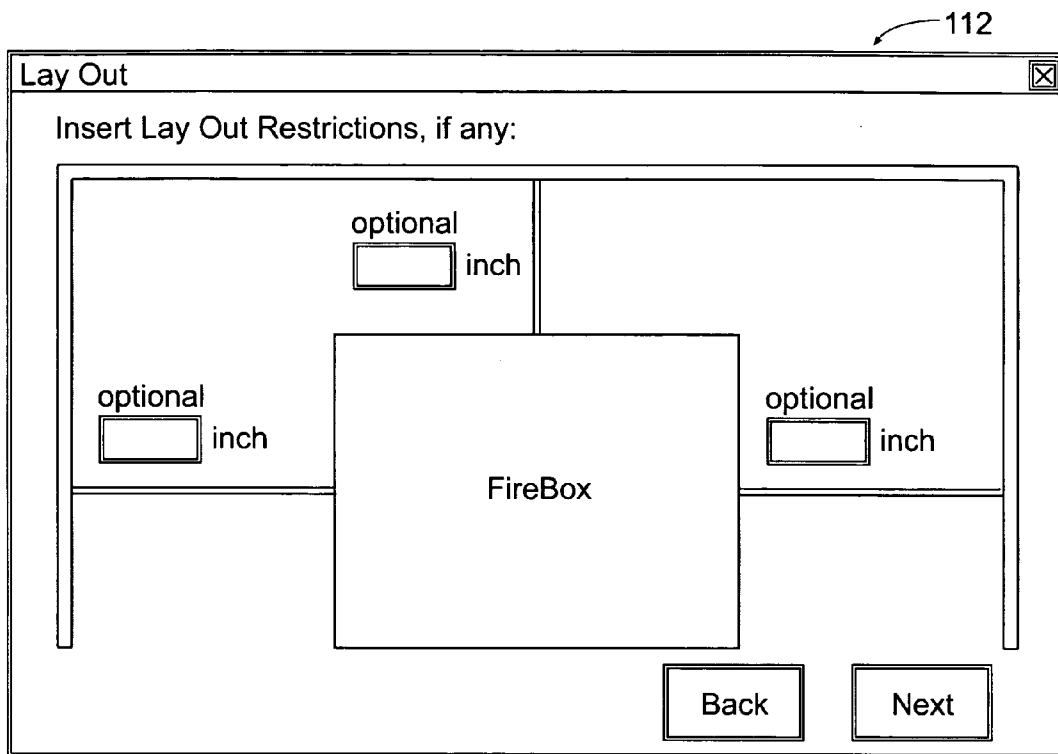


Fig. 24

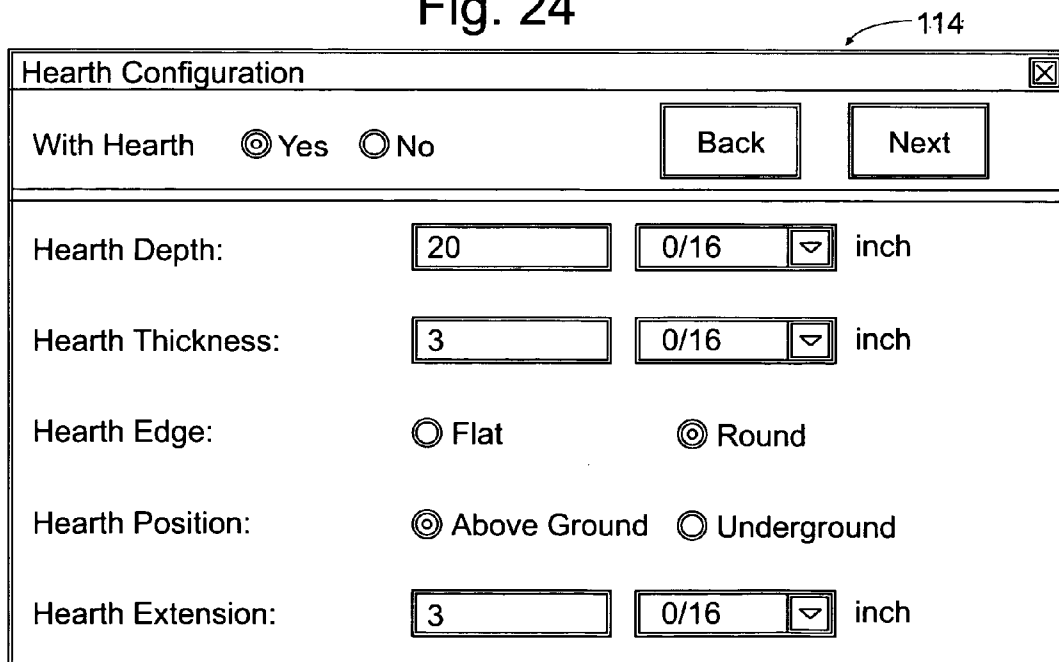


Fig. 25

116

Height of Firebox

Height of Firebox above Floor Line: 0/16 inch

Fig. 26

118

Configuration

Filler Configuration:

Without Top Filler and Side Fillers,

The Mantel Width (Shelf width) will be: inches

The Mantel Height (from floor to shelf) will be: inches

You selected a standard firebox with the width of inches

Do you want to extend the mantel width to another standard Firebox by adding side fillers? Yes No

Select a standard box width: inches

Do you want to extend the mantel height by adding top filler? Yes No

Mantel height you want to be: 0/16 inch

From floor to shelf

Fig. 27

120

Quantity

Insert Fireplace Quantity:

Quantity:

Color:

Finish:

Material:

Install:

- Smooth
- Light Pitted Distressed
- Heavy Pitted Distressed
- Light Acid Wash
- Heavy Acid Wash
- Sand Blasted
- Antiqued

Back Next

Fig. 28

122

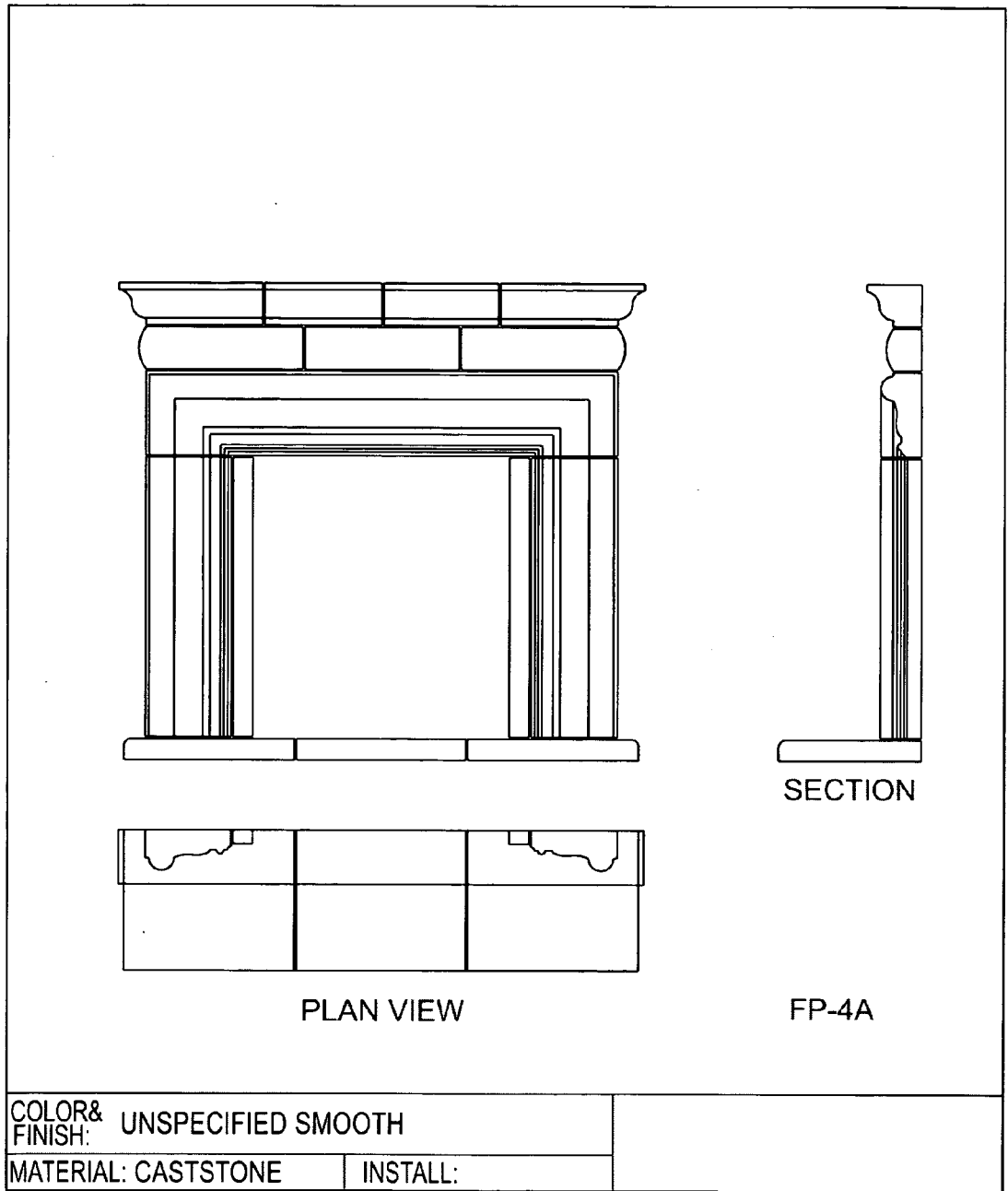


Fig. 29

METHOD AND SYSTEM FOR EMBELLISHING ARCHITECTURAL STRUCTURES

CROSS-REFERENCE TO RELATED APPLICATIONS

[0001] This application for a utility patent claims the benefit of U.S. Provisional Application No. 60/537,589, filed Jan. 20, 2004, which is hereby incorporated by reference in its entirety.

STATEMENT REGARDING FEDERALLY SPONSORED RESEARCH

[0002] Not Applicable

BACKGROUND OF THE INVENTION

[0003] 1. Field of the Invention:

[0004] This invention relates generally to architectural structures, and more particularly to a method of embellishing architectural structures.

[0005] 2. Description of the Related Art:

[0006] For centuries hand cut stone has been used in architecture to add enduring beauty and elegance. Architectural cast stone is an affordable and durable alternative to natural stone, and can be molded to look like hand cut stone. Modern molding techniques can substantially eliminate unwanted air voids in cast stone products, and the color and finish of cast stone can be selected to match (or to contrast with) adjacent architectural features, including aged and/or weathered features.

[0007] For example, Austin, U.S. Pat. No. 6,113,995, teaches a process for creating multicolor designs and patterns in cast stone products so that they imitate natural stone in appearance. The process includes the steps of preparing multiple colors of the casting material, geometrically loading these colors in a three dimensional array in a holding container according to formulas corresponding to particular patterns to be created, placing the geometrically loaded colors into a mold by means which include pouring, extruding and spraying, consolidating the mixtures in the mold and allowing them to set, and removing the cast structure from the mold followed by polishing and sealing if required. A removable matrix in the holding container provides the ability to reliably repeat patterns according to the loading formulas.

[0008] Sheahan et al., U.S. Pat. No. 5,787,667, teaches a casting that has a surface appearance simulating carved stone, and is especially adapted for use as a transition between a brick or stone wall and window and door openings. Further, it provides architectural detail to building constructions, especially as a surround for window and door openings. The casting is produced from a mixture of graded aggregates and a resin binder, combined in predetermined proportions to make a soupy mixture that is cast in a mold. The mold is vibrated to cause migration of air bubbles away from the surface of the molded product, and to cause realignment and orientation of the aggregate materials in a way to enhance the structure and surface density of the product. After the casting has set, it is removed from the mold and cured and the surface is sandblasted to erode away some of the resin binder and portions of the aggregate at the

surface to produce an appearance that is an accurate simulation of carved stone. The cast product, when used as a trim component for architectural detail in building construction, may have shaped portions to accommodate straight runs of brick or stone work, minimizing the need for cutting or shaping the bricks or stones to fit around the casting.

[0009] The process of selecting the proper stone or cast stone embellishments, and producing the embellishments in the correct size and quantity, has typically required a great deal of effort. It would be advantageous to have a method and system for designing architectural structures that may be used to design cut and cast stone products quickly, efficiently, and accurately.

SUMMARY OF THE INVENTION

[0010] A method is disclosed for embellishing an architectural structure. Information is first received indicative of a dimension of the architectural structure and the selected embellishment of the architectural structure along the dimension. A mold is selected from a library of molds to construct the selected embellishment. The dimension of the architectural structure and dimensional information of the selected mold are used to calculate a dimension of the selected embellishment. A described computer system is configured to carry out the method. A computer-readable medium is disclosed including program instructions for carrying out the method.

[0011] Other features and advantages of the present invention will become apparent from the following more detailed description, taken in conjunction with the accompanying drawings, which illustrate, by way of example, the principles of the invention.

BRIEF DESCRIPTION OF THE DRAWING

[0012] The accompanying drawings illustrate the present invention. In such drawings:

[0013] FIG. 1A is a diagram of one embodiment of a computer system including a software program for carrying out a method for designing architectural structures, wherein a computer-readable medium may be used to introduce the software program to the computer system;

[0014] FIG. 1B is a diagram illustrating one embodiment of the software program of FIG. 1A;

[0015] FIG. 1C is a diagram of one embodiment of the computer-readable medium of FIG. 1A;

[0016] FIG. 2 is a flowchart of one embodiment of a method for designing architectural structures;

[0017] FIGS. 3-12 illustrate images displayed on a display screen during a design of an eyebrow window using the software program of FIGS. 1A-1B;

[0018] FIGS. 13-20 illustrate images displayed on a display screen during a design of a column using the software program of FIGS. 1A-1B; and

[0019] FIGS. 21-29 illustrate images displayed on a display screen during a design of a fireplace using the software program of FIGS. 1A-1B.

DETAILED DESCRIPTION OF THE INVENTION

[0020] FIG. 1A is a diagram of one embodiment of a computer system 10 configured to carry out a method for

selecting embellishments for an architectural structure. Several embodiments of the method are described in detail below; however, it should be noted that the method is particularly suited for the selection of embellishments to be fabricated using cut stone or cast stone, and may be adapted to be used in selecting embellishments that may be used in architectural structures including but not limited to windows, doors, columns, walls, fireplaces, balustrades, mailboxes, fountains, landscapes, and carved reliefs. It is noted that the method may also be used to design embellishments for other architectural structures that include similar embellishments.

[0021] In the embodiment of FIG. 1A, the computer system 10 includes a processor 12 coupled to a memory 14. Since such a computer system is well known in the art, it is not described in greater detail herein. Stored within the memory 14 are a library of architectural structures 16, a library of embellishments 18, a library of molds 24, and a software program 30. The library of architectural structures 16 includes information regarding a number of architectural structures (e.g., windows, columns, fireplaces, etc). The library of embellishments 18 includes information regarding a number of embellishments that may be applied to the architectural structures in the library of architectural structures 16. Exemplary embellishments include, but are not limited to, trims, water tables, bandings, sills, cornices, column shapes and designs, bases, capitals, balusters, newel posts, column caps, parapet coping, wall caps, carved urns, planters, filigrees, cartouches, relief bandings, medallions, and rosettes. As indicated in FIG. 1A the library of embellishments 18 includes pictures 20 of the embellishments, such as diagrams or images or graphical representations, and colors/textures/materials 22 available for each of the embellishments.

[0022] The library of molds 24 includes information regarding a number of molds used to make the architectural structures in the library of architectural structures 16 and the embellishments in the library of embellishments 18. As indicated in FIG. 1A, the library of molds 24 includes information regarding a shape/cross-section 26 of each of the available molds, and minimum/maximum sizes/lengths (i.e., dimensions) 28 of each of the available molds.

[0023] In one embodiment, the library of molds 24 includes dimensional information and a graphical representation of each of several available molds. Some of the molds have a fixed dimension (e.g., length), and others have a variable dimension. The dimensional information of each mold having a variable dimension includes a minimum dimension of the mold and a maximum dimension of the mold. (The dimensional information of each mold with a fixed dimension may also include a minimum dimension and a maximum dimension, where the minimum and maximum dimensions are equal.)

[0024] In general, the processor 12 fetches instructions from the memory 14 and executes the instructions. The software program 30 includes, in general, instructions for carrying out the steps of the method.

[0025] FIG. 1B is a diagram illustrating one embodiment of the software program 30 of FIG. 1A. In the embodiment of FIG. 1B, the software program 30 includes software for receiving selection of architectural structures 32, software for receiving dimensions of architectural structures 34, soft-

ware for receiving selection(s) of embellishment(s) 36, software for receiving selection(s) of characteristic(s) of the embellishment(s) 38, software for selecting appropriate mold(s) to generate the embellishment(s) 40, software for calculating a size/length of each embellishment based on min/max sizes of each mold 42, software for generating a list of materials 44, and software for generating a shop drawing 46.

[0026] In general, when the processor 12 of FIG. 1A executes the instructions of the software for receiving selection of architectural structures 32, the computer system 10 of FIG. 1A receives information indicative of a selected architectural structure (i.e., a selected one of the architectural structures of the library of architectural structures 16). Thus the software for receiving selection of architectural structures 32 and the processor 12 represent means within the computer system 10 for receiving information indicative of the selected architectural structure.

[0027] When the processor 12 of FIG. 1A executes the instructions of the software for receiving dimensions of architectural structures 34, the computer system 10 of FIG. 1A receives information indicative of one or more dimensions of the selected architectural structure. Thus the software for receiving dimensions of architectural structures 34 and the processor 12 represent means within the computer system 10 for receiving information specifying one or more dimensions of the selected architectural structure.

[0028] When the processor 12 of FIG. 1A executes the instructions of the software for receiving selection(s) of embellishment(s) 36, the computer system 10 of FIG. 1A receives information indicative of one or more selected embellishments of the selected architectural structure along the one or more dimensions of the selected architectural structure. Thus the software for receiving selection(s) of embellishment(s) 36 and the processor 12 represent means within the computer system 10 for receiving information indicative of one or more selected embellishments of the selected architectural structure along the one or more dimensions of the selected architectural structure.

[0029] When the processor 12 of FIG. 1A executes the instructions of the software for receiving selection(s) of characteristic(s) of embellishment(s) 38, the computer system 10 of FIG. 1A receives information indicative of one or more selected characteristics of the selected embellishments. Thus the software for receiving selection(s) of characteristic(s) of embellishment(s) 38 and the processor 12 represent means within the computer system 10 for receiving information indicative of one or more selected characteristics of the selected embellishments.

[0030] When the processor 12 of FIG. 1A executes the instructions of the software for selecting appropriate mold(s) to generate embellishment(s) 40, the software program 30 selects one or more of the molds of the library of molds 24 to form the features of the selected architectural structure. Thus the software for selecting appropriate mold(s) to generate embellishment(s) 40 and the processor 12 represent means within the computer system 10 of FIG. 1A for selecting one or more molds to form the selected embellishments.

[0031] When the processor 12 of FIG. 1A executes the instructions of the software for calculating the size/length of

each embellishment based on the min/max size of each mold **42**, the software program **30** calculates the size and shape of all required features of an architectural structure dependent upon the minimum and maximum sizes and lengths stored in the library of molds **24**. Thus the software for calculating the size/length of each embellishment based on the min/max size of each mold **42** and the processor **12** represent means within the computer system **10** for calculating at least one dimension of each selected embellishment based on dimensional information of corresponding selected molds.

[0032] Some embellishments are formed using molds having fixed dimensions. As a result, the sizes of these features cannot be changed (as indicated in the corresponding entry in the library of molds **24**). In general, the software for calculating the size/length of each embellishment based on the min/max size of each mold **42** (i.e., the “calculating software **42**”) first enters the sizes of all features with fixed sizes, then calculates the sizes of components formed using molds with dimensions that can be varied. For example, if a given mold can create trim sections that are from 5 to 10 inches, and a total length of 36 inches is required, the calculating software **42** may calculate that **4** sections would be required to form a trim embellishment, each having a length of 9 inches.

[0033] When the processor **12** of **FIG. 1A** executes the instructions of the software for generating a list of materials **44**, the computer system **10** of **FIG. 1A** generates a list of materials required to form the selected architectural feature. The list of materials (i.e., materials list) specifies which molds are to be used, as well as how many parts should be made from each mold, and the specific size and shape of each part to be fabricated. Similarly, when the processor **12** of **FIG. 1A** executes the instructions of the software for generating a shop drawing **46**, the computer system **10** of **FIG. 1A** generates the shop drawing of the selected architectural feature. In general, the shop drawing illustrates the different components of the architectural structure and the relative positioning of the components with respect to the architectural structure.

[0034] Referring back to **FIG. 1A**, a computer-readable medium **48** may be used to introduce the software program **30** to the computer system **10**, and may also be used to introduce the library of architectural structures **16**, the library of embellishments **18**, and/or the library molds **24**. **FIG. 1C** is a diagram of one embodiment of the computer-readable medium **48** of **FIG. 1A**. In the embodiment of **FIG. 1C**, the medium **48** includes the software program **30**, and may also include, as indicated, the library of architectural structures **16**, the library of embellishments **18**, and/or the library of molds **24**.

[0035] For example, the computer system **10** of **FIG. 1A** may include a disk drive for receiving removable disks (e.g., a floppy disk drive, a compact disk read only memory or CD-ROM drive, etc.), and the medium **48** of **FIGS. 1A** and **1C** may be a disk (e.g., a floppy disk, a CD-ROM disk, etc.) embodying the software program **30**. The processor **12** of **FIG. 1A** may read the instructions of the software program **30** from the medium **48** and store the instructions in the memory **14**.

[0036] **FIG. 2** is a flowchart of one embodiment of a method **50** for designing architectural structures. The method **50** of **FIG. 2** may be embodied within the software

program **30** of **FIGS. 1A-1C**. In the embodiment of **FIG. 2**, a step **52** of the method **50** includes receiving a selection of an architectural structure. For example, as indicated in **FIG. 2**, the selected architectural structure may be a window, a column, or any other number of architectural structures. A particular window may be, for example, a flat top window, an eyebrow window, an oval window, or other type of window. A particular column may have, for example, a smooth shaft, a fluted shaft, a specific type of capital and base, or may have other distinguishing features.

[0037] During a step **54**, dimensions of the selected architectural structure are received from either: (i) a library of manufacturers' products, or (ii) dimensions entered by a user of the software program **30** of **FIGS. 1A-1C**. Selections of one or more embellishments along the dimensions of the selected architectural structure are received during a step **56**. As indicated in **FIG. 2**, the embellishments may include, for example, a border/trim, accessories such as keystones, plinth blocks, etc.

[0038] During a step **58**, one or more selections of characteristics of the embellishments are received. In the embodiment of **FIG. 2**, the selected characteristics of the embellishments may include, for example, color, texture, material, shape, and/or cross-section.

[0039] One or more molds necessary to construct the embellishments are selected from the library of molds **24** of **FIG. 1A** during a step **60**. During a step **62**, the size/length of each selected embellishment is calculated. In general, the size/length of each embellishment is dependent upon a minimum size and a maximum size of corresponding molds so that the selected embellishments fit the selected architectural structure.

[0040] In some cases, two embellishments are selected along a particular dimension of the selected architectural structure. For example, a first of two selected embellishments along a dimension of a selected architectural structure may have a fixed length, and the second may have a variable length. In this situation, the step **62** involves calculating a required number of sections of the selected embellishment and a dimension (e.g., length) of each of the sections. The library of molds **24** of **FIG. 1** is accessed to obtain the dimensional information of a first mold and a second mold used to form the first and second embellishments, respectively. The fixed dimension of the first mold is subtracted from the dimension of the architectural structure to obtain a remainder dimension. The remainder dimension, the minimum dimension of the second mold, and the maximum dimension of the second mold are used to calculate a required number of sections of the second embellishment and a dimension of each of the sections. The dimension or each of the sections is greater than or equal to the minimum dimension of the second mold, and less than or equal to the maximum dimension of the second mold, and the sum of the dimensions of the sections is substantially equal to the remainder dimension. For purposes of this application, the term “substantially equal” is intended to mean that the sums are equal for purposes of this type of construction. Obviously, there is room for a margin or error, since great precision is generally not required. Also, an allowance may be made for spacing between the embellishments, and such spacing may be provided for either automatically or manually, if required and/or desired.

[0041] A list of materials is generated during a step 64 that specifies the one or more molds selected from them library of molds 24 of FIG. 1A, and the size/shape of each of the part to be fabricated to form the selected architectural structure and the selected embellishments. A shop drawing is generated during a step 66 that illustrates the selected architectural structure, the selected embellishments, and how the embellishments are to be integrated into the architectural structure.

[0042] For example, during the step 66, the library of architectural structures 16 of FIG. 1 may be accessed to obtain a graphical representation of the selected architectural structure, and the library of molds 24 of FIG. 1 may be accessed to obtain graphical representations of the selected embellishments. The graphical representation of the architectural structure and the graphical representations of the selected embellishments may be used to generate an image of the architectural structure and the selected embellishments, wherein the image indicates the relative positioning of the selected embellishments with respect to the architectural structure.

[0043] FIGS. 3-12 will now be used to illustrate the design of a window, and particularly an eyebrow window, using the software program 30 of FIGS. 1A-1C. For purposes of this application, the term window should also be construed to include doors and other apertures that are structurally similar or equivalent to a window. As noted above, the method 50 of FIG. 2 may be embodied within the software program 30. FIG. 3 is a diagram depicting an image 70 displayed on a display screen of the computer system 10 of FIG. 1A during selection of the architectural structure (e.g., during step 52 of method 50 of FIG. 2). The image 70 includes graphical representations (e.g., pictures, images, or diagrams) of several available window styles including a "Flat Top" style, an "Eyebrow" style, a "Half Round" style, an "Oval or Circle" style, and any other styles that may be desirable or are known to those skilled in the art. The user of the software program 30 selects a desired one of the available window styles (e.g., via a mouse of the computer system 10 of FIG. 1A). In the current example the user selects the Eyebrow style, then selects a "Next" button.

[0044] FIG. 4 is a diagram depicting an image 72 displayed on the display screen of the computer system 10 of FIG. 1A during selection of embellishments to add to the architectural structure (e.g., during the step 56 of the method 50 of FIG. 2). When the image 72 is displayed on the display screen, the user of the software program 30 of FIGS. 1A-1C first indicates a desire to select a trim style by selecting a "Yes" radio button (e.g., via the mouse). The image 72 includes graphical representations of several available trim styles including a "Flat Trim" style, a "CL" style, an "RPM" style, and an "RCSL" style. (The designators "CL," "RPM," and "RCSL" are internal designations used to identify the particular cross-sections of the trims styles as indicated in FIG. 4.) In the current example the user selects the Yes radio button, the CL trim style, and finally the Next button.

[0045] FIG. 5 is a diagram depicting an image 74 displayed on the display screen of the computer system 10 of FIG. 1A during selection of characteristics of the embellishments (e.g., during the step 58 of the method 50 of FIG. 2). In FIG. 5, the user of the software program 30 of FIGS. 1A-1C selects one of several available trim sizes from a

drop-down list. In the embodiment of FIG. 5 the dimensions in the drop-down list are in inches, and correspond to the dimensions of the trim styles shown in FIG. 4. After selecting the trim size, the user selects the Next button.

[0046] FIG. 6 is a diagram depicting an image 76 displayed on the display screen of the computer system 10 of FIG. 1A during selection of the characteristics of the embellishments (e.g., during the step 58 of the method 50 of FIG. 2). In the embodiment of FIG. 6, the user indicates a desire to include plinth blocks by selecting the Yes radio button. The user then enters a height in inches in a "Height" text box, selects a number of sixteenths of an inch for the height dimension from a drop-down list, then selects the Next button.

[0047] FIG. 7 is a diagram depicting an image 78 displayed on the display screen of the computer system 10 of FIG. 1A during selection of the embellishments to add to the architectural structure (e.g., during the step 56 of the method 50 of FIG. 2). In the embodiment of FIG. 7, the user indicates a desire to include a keystone (i.e., a "key") by selecting the Yes radio button. The image 78 includes graphical representations of several available key styles including a "CH" style, an "FL" style, a "REC" style, a "CHBM" style, and an "FLBM" style. (The designators "CH," "FL," "REC," "CHBM," and "FLBM" are internal designations used to identify the particular key styles as indicated in FIG. 7.) In the current example the user selects the CHBM style, then selects the Next button.

[0048] FIG. 8 is a diagram depicting an image 80 displayed on the display screen of the computer system 10 of FIG. 1A during selection of the characteristics of the embellishments (e.g., during the step 58 of the method 50 of FIG. 2). In the embodiment of FIG. 8, the user selects a "Y" dimension of the selected CHBM style key (see FIG. 7) in inches from a drop-down list, then selects the Next button.

[0049] FIG. 9 is a diagram depicting an image 82 displayed on the display screen of the computer system 10 of FIG. 1A during the selection of another embellishment of the eyebrow window (e.g., during the step 56 of the method 50 of FIG. 2). In the embodiment of FIG. 9, the user of the software program 30 of FIGS. 1A-1C indicates a desire to include a sill by selecting the Yes radio button. The image 82 includes graphical representations of several available sill styles including a "Sill-DL278" style, a "Sill-BNOG500" style, and a "Sill-BNC375" style. In the current example the user of the software program 30 of FIGS. 1A-1C selects the Sill-BNC375 style, then selects the Next button.

[0050] FIG. 10 is a diagram depicting an image 84 displayed on the display screen of the computer system 10 of FIG. 1A during receiving of the dimensions of the architectural structure (e.g., during the step 54 of the method 50 of FIG. 2). In the embodiment of FIG. 10, the user of the software program 30 of FIGS. 1A-1C enters a width of the eyebrow window in inches in a "Width" text box, and selects a number of sixteenths of an inch for the width dimension from a corresponding drop-down list. The user similarly enters a total height of the eyebrow window and a height of each leg of the eyebrow window in inches in corresponding text boxes, and selects a number of sixteenths of an inch for the total height and leg height from corresponding drop-down lists. The user then selects the Next button.

[0051] In an alternative embodiment, as shown in FIG. 10A, the step of receiving of the dimensions of the archi-

tectural structure (e.g., during the step 54 of the method 50 of FIG. 2) is accomplished with reference to the library of architectural structures 16. In one embodiment, the library of architectural structures 16 includes a manufacturer's name 85A and a model number 85B. In this embodiment, an image 84A displayed on the display screen of the computer system 10 of FIG. 1A receives the manufacturer's name 85A and the model number 85B from the user. The computer system 10 is then able to access dimensions 85C of the architectural structure that are stored in the library of architectural structures 16.

[0052] FIG. 11 is a diagram depicting an image 86 displayed on the display screen of the computer system 10 of FIG. 1A during receiving of the characteristics of the embellishments of the eyebrow window (e.g., during the step 58 of the method 50 of FIG. 2). In the embodiment of FIG. 11, the user enters a desired quantity of the eyebrow windows in a "Quantity" text box, and selects a color from a list of available colors in a corresponding "Color" drop-down list. The user similarly selects a desired finish from a list of available finishes in a "Finish" drop-down list. The user then selects the Next button.

[0053] The computer system 10 then calculates the number of the embellishments, the size of each embellishment, the molds to be used to manufacture the embellishments, and other pertinent information, as described above. In the preferred embodiment, this information is then used to generate a shop drawing 88, such as the one shown in FIG. 12.

[0054] FIG. 12 is one embodiment of the shop drawing 88 generated by the software program 30 of FIGS. 1A-1C (e.g., during the step 66 of the method 50 of FIG. 2). As indicated in FIG. 12, the shop drawing 88 includes both textual and graphical information about the eyebrow window, including the selected embellishments, designed using the software program 30. In the embodiment of FIG. 12, the shop drawing 88 includes a cross-sectional view of the selected Sill, Sill-BNC375, the selected trim style, RPM, and the plinth block corresponding to the selected trim style.

[0055] The shop drawing 88 includes a diagram of the designed eyebrow window with labels next to the components that form keys to the corresponding textual information. For example, in the diagram of the designed eyebrow window, the sill is made up of two sections labeled A1 and A2. The section A1 forms a left portion of the sill, and the section A2 forms a right portion of the sill. In the textual information corresponding to portion A1, the "1 PC" specifies that the eyebrow window includes only one similar portion A1, the "23/8" specifies that the length of the portion A1 is 23/8 inches, and the "LBRTN" designates the type of mold needed to form the portion A1. Similarly, in the textual information corresponding to portion A2, the "1 PC" specifies that the eyebrow window includes only one similar portion A2, the "23/8" specifies that the length of the portion A2 is 23/8 inches, and the "RBRN" designates the type of mold needed to form the portion A2.

[0056] The legs of the designed eyebrow window include two plinth blocks labeled A3, a section labeled A4, and another section A5. An arch of the designed eyebrow window includes sections labeled A6, A7, A8, A9, and the keystone (i.e., key) labeled A10. The color and finish of the eyebrow window are "UNSPECIFIED" and "SMOOTH,"

respectively, as selected by the user of the software program 30 of FIGS. 1A-1C. As indicated in the shop drawing 88 of FIG. 12, the material is "CAST STONE" as selected by the user.

[0057] The shop drawing 88 is preferably generated in a CAD format, or other generally used drawing format, so that the drawing of the shop drawing 88 can be readily viewed, and also imported into other viewing software programs. For example, the shop drawing 88 could be imported into a front elevational view of a home being drawn by an architect. This easy importation enables the architect to add drawings of the embellishments to their drawing of the home with minimal additional effort.

[0058] FIGS. 13-20 will now be used to illustrate the design of a column using the software program 30 of FIGS. 1A-1C. As noted above, the method 50 of FIG. 2 may be embodied within the software program 30. FIG. 13 is a diagram depicting an image 90 displayed on the display screen of the computer system 10 of FIG. 1A during selection of the architectural structure (e.g., during step 52 of method 50 of FIG. 2). The image 90 includes graphical representations of several available column styles including an "SS SMOOTH STRAIGHT" style, an "ST SMOOTH TAPERED" style, an "FT FLUTED TAPERED" style, and an "SR SPIRAL WITH ROPE" style. The user of the software program 30 selects a desired one of the available column styles (e.g., via the mouse). In the current example the user selects the SS SMOOTH STRAIGHT style, then selects the Next button.

[0059] FIG. 14 is a diagram depicting an image 92 displayed on the display screen of the computer system 10 of FIG. 1A during receiving of the dimensions of the architectural structure (e.g., during the step 54 of the method 50 of FIG. 2). In the embodiment of FIG. 14, the user enters a base diameter in inches in a "Base Diameter" text box and selects a number of sixteenths of an inch for the base diameter dimension from a drop-down list. The user also enters a total height in inches in a "Total Height" text box and selects a number of sixteenths of an inch for the total height dimension from a drop-down list. The user then selects the Next button.

[0060] FIG. 15 is a diagram depicting an image 94 displayed on the display screen of the computer system 10 of FIG. 1A during selection of embellishments to add to the architectural structure (e.g., during the step 56 of the method 50 of FIG. 2). The image 94 includes graphical representations of available base styles including a "DORIC" style and a "TUSCAN" style. In the current example the user selects the DORIC base and then the Next button.

[0061] FIG. 16 is a diagram depicting an image 96 displayed on the display screen of the computer system 10 of FIG. 1A during selection of embellishments to add to the architectural structure (e.g., during the step 56 of the method 50 of FIG. 2). The image 96 includes graphical representations of available bases including a "DB120D-1" base and a "DB120D-2" base. (The designators "DB120D-1" and "DB120D-2" are internal designations used to identify the particular bases as indicated in FIG. 16). In the current example the user selects the DB120D-1 base and then the Next button.

[0062] FIG. 17 is a diagram depicting an image 98 displayed on the display screen of the computer system 10 of

FIG. 1A during selection of embellishments to add to the architectural structure (e.g., during the step 56 of the method 50 of **FIG. 2**). The image 98 includes graphical representations of available capital styles including a “DORIC” style and a “TUSCAN” style. In the current example the user selects the TUSCAN capital and then the Next button.

[0063] **FIG. 18** is a diagram depicting an image 100 displayed on the display screen of the computer system 10 of **FIG. 1A** during selection of embellishments to add to the architectural structure (e.g., during the step 56 of the method 50 of **FIG. 2**). The image 100 includes graphical representations of available capitals including a “TC1200D-1” base and a “TC1200D-2” capital. (The designators “TC1200D-1” and “TC1200D-2” are internal designations used to identify the particular capitals as indicated in **FIG. 18**). In the current example the user selects the TC1200D-2 capital and then the Next button.

[0064] **FIG. 19** is a diagram depicting an image 102 displayed on the display screen of the computer system 10 of **FIG. 1A** during receiving of the characteristics of the embellishments of the eyebrow window (e.g., during the step 58 of the method 50 of **FIG. 2**). In the embodiment of **FIG. 19**, the user enters a desired quantity of the eyebrow windows in a “Quantity” text box, and selects a type from a list of available types in a corresponding “Type” drop-down list. The user selects “Yes” or “No” from a “With Flat Base” drop-down list. If the user enters “Yes” in the “With Flat Base” drop-down list, the user enters a flat base height in inches in a “Flat Base Height” text box and selects a number of sixteenths of an inch for the flat base height dimension from a drop-down list. The user may also select a color from a list of available colors in a “Color” drop-down list, a material from a list of available materials in a “Material” drop-down list, and a finish from a list of available finishes in a “Finish” drop-down list. The user then selects the Next button to proceed.

[0065] As described above, the computer system 10 then calculates all of the necessary information to manufacture the column. For example, the total height of the column is reduced by the height of the capital and the base that were selected, to determine the total length of the column shaft.

[0066] **FIG. 20** is one embodiment of a shop drawing 104 generated by the software program 30 of **FIGS. 1A-1C** (e.g., during the step 66 of the method 50 of **FIG. 2**), based upon these calculations. As indicated in **FIG. 20**, the shop drawing 104 includes both textual and graphical information about the column, including the selected embellishments, designed using the software program 30. In the embodiment of **FIG. 20**, the shop drawing 104 includes a side elevation view of the designed column with the selected SS SMOOTH STRAIGHT shaft, the selected DORIC base BD1200D-1, and the selected TUSCAN capital TC1200D-2.

[0067] In the textual information corresponding to the TUSCAN capital, the “TC1200D-2” specifies the type of mold needed to form the capital, the “2 HALVES” specifies the TUSCAN capital is formed by joining together 2 substantially identical portions, and the “12 DIAM×6¾ TALL” specifies that the diameter of a circular bottom portion of the TUSCAN capital has a diameter of 12 inches and a total height of the TUSCAN capital is 6¾ inches. The textual information corresponding to the SS SMOOTH STRAIGHT shaft and the DORIC base give similar information. The

color and finish of the designed column are “UNSPECIFIED” and “SMOOTH,” respectively, as selected by the user of the software program 30 of **FIGS. 1A-1C**. As indicated in the shop drawing 104 of **FIG. 20**, the material is “CAST STONE” as selected by the user.

[0068] **FIGS. 21-29** will now be used to illustrate the design of a fireplace using the software program 30 of **FIGS. 1A-1C**. As noted above, the method 50 of **FIG. 2** may be embodied within the software program 30. **FIG. 21** is a diagram depicting an image 106 displayed on the display screen of the computer system 10 of **FIG. 1A** during selection of the architectural structure (e.g., during step 52 of method 50 of **FIG. 2**). The image 106 includes graphical representations of available fireplace categories including a “Traditional” category and a “Classic” category. The user of the software program 30 selects a desired one of the available fireplace categories (e.g., via the mouse). In the current example the user selects the Traditional category, then selects the Next button.

[0069] **FIG. 22** is a diagram depicting an image 108 displayed on the display screen of the computer system 10 of **FIG. 1A** during selection of the architectural structure (e.g., during step 52 of method 50 of **FIG. 2**). The image 108 includes graphical representations of available fireplace styles including an “FP-4” style and a “FP-5” style. (The designators “FP-4” and “FP-5” are internal designations used to identify the particular fireplaces as indicated in **FIG. 22**). In the current example the user selects the FP-4 style and then the Next button.

[0070] **FIG. 23** is a diagram depicting an image 110 displayed on the display screen of the computer system 10 of **FIG. 1A** during receiving of the dimensions of the architectural structure (e.g., during the step 54 of the method 50 of **FIG. 2**). In the embodiment of **FIG. 23**, the user can either: (i) enter fire box dimensions by hand, or (ii) select from a list of standard fire box dimensions. If the user elects to enter the fire box dimensions by hand, the user enters a width dimension in inches in a “Fire Box Width” text box and selects a number of sixteenths of an inch for the width dimension from a drop-down list. The user also enters a height dimension in inches in a “Fire Box Height” text box and selects a number of sixteenths of an inch for the height dimension from a drop-down list.

[0071] If, on the other hand, the user elects to select from the list of standard fire box dimensions, the user selects a radio button next to a selected one of the listed standard fire box dimensions. In either case, after having specified the fire box dimensions, the user selects the Next button.

[0072] **FIG. 24** is a diagram depicting an image 112 displayed on the display screen of the computer system 10 of **FIG. 1A** during receiving of the dimensions of the architectural structure (e.g., during the step 54 of the method 50 of **FIG. 2**). In the embodiment of **FIG. 24**, the user is given the opportunity to enter any lay out restrictions surrounding the fire box. If the user elects to enter lay out restrictions, the user enters the lay out restriction dimension in inches in corresponding text boxes as shown in **FIG. 24**, and then selects the Next button.

[0073] **FIG. 25** is a diagram depicting an image 114 displayed on the display screen of the computer system 10 of **FIG. 1A** during receiving of the dimensions of the

architectural structure (e.g., during the step 54 of the method 50 of FIG. 2). In the embodiment of FIG. 25, the user first indicates a desire to include a hearth by selecting the Yes radio button. After selecting the Yes radio button, the user enters a depth dimension of the hearth in inches in a "Hearth Depth" text box and selects a number of sixteenths of an inch for the hearth depth dimension from a drop-down list. The user selects between a "Flat" and a "Round" hearth edge by selecting the corresponding radio button. The user selects between an "Above Ground" and an "Underground" hearth position by selecting the corresponding radio button. The user enters a hearth extension dimension in inches in a "Hearth Extension" text box and selects a number of sixteenths of an inch for the hearth extension dimension from a drop-down list. The user then selects the Next button.

[0074] FIG. 26 is a diagram depicting an image 116 displayed on the display screen of the computer system 10 of FIG. 1A during receiving of the dimensions of the architectural structure (e.g., during the step 54 of the method 50 of FIG. 2). In the embodiment of FIG. 26, the user enters a height of the fire box above floor level in inches in a corresponding text box and selects a number of sixteenths of an inch for the height dimension from a drop-down list.

[0075] FIG. 27 is a diagram depicting an image 118 displayed on the display screen of the computer system 10 of FIG. 1A during receiving of the dimensions of the architectural structure (e.g., during the step 54 of the method 50 of FIG. 2). In the embodiment of FIG. 27, the software program 30 of FIGS. 1A-1C computes a mantel width dimension and a mantel height dimension, and displays the mantel width dimension, the mantel height dimension, and the selected fire box width to the user as part of the image 118. The user is given the opportunity to extend the mantel width dimension by adding side fillers and/or increasing the selected fire box width, and to extend the mantel height dimension by adding a top filler. The user then selects the Next button.

[0076] FIG. 28 is a diagram depicting an image 120 displayed on the display screen of the computer system 10 of FIG. 1A during receiving of the characteristics of the embellishments of the fireplace (e.g., during the step 58 of the method 50 of FIG. 2). In the embodiment of FIG. 28, the user enters a desired quantity in a "Quantity" text box, selects a color from a list of available colors in a corresponding "Color" drop-down list, a desired finish from a list of available finishes in a "Finish" drop-down list, and a material in a "Material" text box. Those skilled in the art will recognize that other features and/or parameters of the fireplace may also be specified, and such alternatives should be considered within the scope of the claimed invention. The user then selects the Next button to proceed.

[0077] FIG. 29 is one embodiment of a shop drawing 122 generated by the software program 30 of FIGS. 1A-1C (e.g., during the step 66 of the method 50 of FIG. 2). As indicated in FIG. 29, the shop drawing 122 includes a front elevation view, a section view, and a plan view of the designed fireplace, and textual information specifying the selected FP-4 fireplace style. The color and finish of the designed column are "UNSPECIFIED" and "SMOOTH," respectively, as selected by the user of the software program 30 of FIGS. 1A-1C. As indicated in the shop drawing 104 of FIG. 20, the material is "CAST STONE" as selected by the user.

[0078] It is noted that many other embellishments are known and may be made available in the software program 30 of FIGS. 1A-1C. Examples of known and common embellishments include trims, watertables, bandings, sills, cornices, column shapes and designs, bases, capitals, balustrades, newel posts, column caps, parapet coping, wall caps, carved urns, planters, filigrees, cartouches, relief bandings, medallions, and rosettes.

[0079] While the invention has been described with reference to at least one preferred embodiment, it is to be clearly understood by those skilled in the art that the invention is not limited thereto. Rather, the scope of the invention is to be interpreted only in conjunction with the appended claims.

What is claimed is:

1. A method for embellishing an architectural structure, the method comprising the steps of:

receiving information indicative of a dimension of the architectural structure;

receiving information indicative of a selected embellishment of the architectural structure along the dimension;

selecting a mold to construct the selected embellishment;

associating the mold with dimension information that includes a minimum dimension and a maximum dimension of the selected mold; and

using the dimension of the architectural structure and the dimensional information of the selected mold to calculate how many segments of the selected embellishment are required, and a dimension of each of the segments of the selected embellishment.

2. The method as recited in claim 1, wherein the selected embellishment is cast stone.

3. The method as recited in claim 1, wherein the using the dimension of the architectural structure and dimensional information of the selected mold to calculate a dimension of the selected embellishment comprises:

accessing a library of molds to obtain the dimensional information of the selected mold.

4. The method as recited in claim 3, wherein the library of molds comprises dimensional information corresponding to a plurality of molds.

5. The method as recited in claim 4, wherein a first portion of the molds within the library of molds have a fixed dimension, and wherein a remainder of the molds have a variable dimension.

6. The method as recited in claim 1, wherein the dimension of the architectural structure is received from a library of architectural structures.

7. The method as recited in claim 6, wherein the library of architectural structures includes a manufacturer name and a model number.

8. The method as recited in claim 1, wherein the dimension of the architectural structure is received via a manual input.

9. The method as recited in claim 1, wherein the architectural structure is selected from the group consisting of: a window, a column, and a fireplace.

10. The method as recited in claim 9, wherein in the event the architectural structure is a window, the selected embellishment includes a trim style, a keystone style, and/or a sill style.

11. The method as recited in claim 9, wherein in the event the architectural structure is a column, the selected embellishment includes a shaft style, a base style, and/or a capital style.

12. The method as recited in claim 1, further comprising:
receiving information indicative of a selected characteristic of the selected embellishment.

13. The method as recited in claim 12, wherein the selected characteristic of the selected embellishment includes a color, a texture, a material, shape, and/or a cross sectional pattern.

14. The method as recited in claim 1, further comprising:
generating a list of materials specifying the selected mold and the calculated dimension of the selected embellishment.

15. The method as recited in claim 1, further comprising:
generating a shop drawing illustrating the architectural structure and the selected embellishment.

16. A method for embellishing an architectural structure, comprising:

receiving information indicative of a dimension of the architectural structure;

receiving information indicative of a first selected embellishment of the architectural structure along the dimension;

receiving information indicative of a second selected embellishment of the architectural structure along the dimension;

selecting a first mold to construct the first selected embellishment;

selecting a second mold to construct the second selected embellishment; and

using the dimension of the architectural structure, dimensional information of the first mold, and dimensional information of the second mold to calculate a dimension of the second selected embellishment.

17. The method as recited in claim 16, wherein the first mold has a fixed dimension and the second mold has a variable dimension.

18. The method as recited in claim 17, wherein the dimensional information of the second mold comprises a minimum dimension and a maximum dimension of the second mold.

19. The method as recited in claim 18, wherein the using the dimension of the architectural structure, dimensional information of the first selected mold, and dimensional information of the second selected mold to calculate a dimension of the first selected embellishment comprises:

accessing a library of molds to obtain the dimensional information of the first mold;

subtracting the fixed dimension of the first mold from the dimension of the architectural structure to obtain a remainder dimension;

accessing the library of molds to obtain the dimensional information of the second mold;

using the remainder dimension, the minimum dimension of the second mold, and the maximum dimension of the second mold to calculate a required number of sections of the second selected embellishment and a dimension of each of the sections, wherein the dimension or each of the sections is: (i) greater than or equal to the minimum dimension of the second mold, and (ii) less than or equal to the maximum dimension of the second mold, and wherein a sum of the dimensions of the sections is substantially equal to the remainder dimension.

20. The method as recited in claim 16, further comprising:
generating a list of materials specifying the first and second molds, the required number of sections of the second selected embellishment, and the calculated dimension of each of the sections.

21. The method as recited in claim 16, further comprising:
generating a shop drawing illustrating the architectural structure, the first and second selected embellishments, and a relative positioning of the first and second selected embellishments with respect to the architectural structure.

22. The method as recited in claim 21, wherein the generating the shop drawing comprises:

accessing a library of architectural structures to obtain a graphical representation of the architectural structure;

accessing a library of molds to obtain graphical representations of the first and second selected embellishments; and

using the graphical representation of the architectural structure and the graphical representations of the first and second selected embellishments to generate an image of the architectural structure and the first and second selected embellishments, wherein the image indicates the relative positioning of the first and second selected embellishments with respect to the architectural structure.

23. A method for embellishing an architectural structure, comprising:

receiving information indicative of a dimension of the architectural structure;

receiving information indicative of a plurality of embellishments of the architectural structure along the dimension, wherein the plurality of embellishments comprises a first embellishment having a fixed dimension and a second embellishment having a variable dimension;

selecting a first mold to construct the first embellishment;

selecting a second mold to construct the second embellishment, wherein the second mold has a minimum dimension and a maximum dimension; and

calculating, using the dimension of the architectural structure, dimensional information of the first mold, and the minimum and maximum dimensions of the second mold, a required number of sections of the second embellishment and a dimension of each of the sections of the second embellishment, wherein the dimension of

each of the sections of the second embellishment is: (i) greater than or equal to the minimum dimension of the second mold, and (ii) less than or equal to the maximum dimension of the second mold, and wherein the sum of the fixed dimension of the first embellishment and the calculated dimensions of all of the sections of the second embellishment is substantially equal to the dimension of the architectural structure.

24. The method as recited in claim 23, further comprising: receiving information indicative of a selected characteristic of the selected embellishment.

25. The method as recited in claim 24, wherein the selected characteristic of the selected embellishment includes a color, a texture, a material, shape, and/or a cross sectional pattern.

* * * * *