

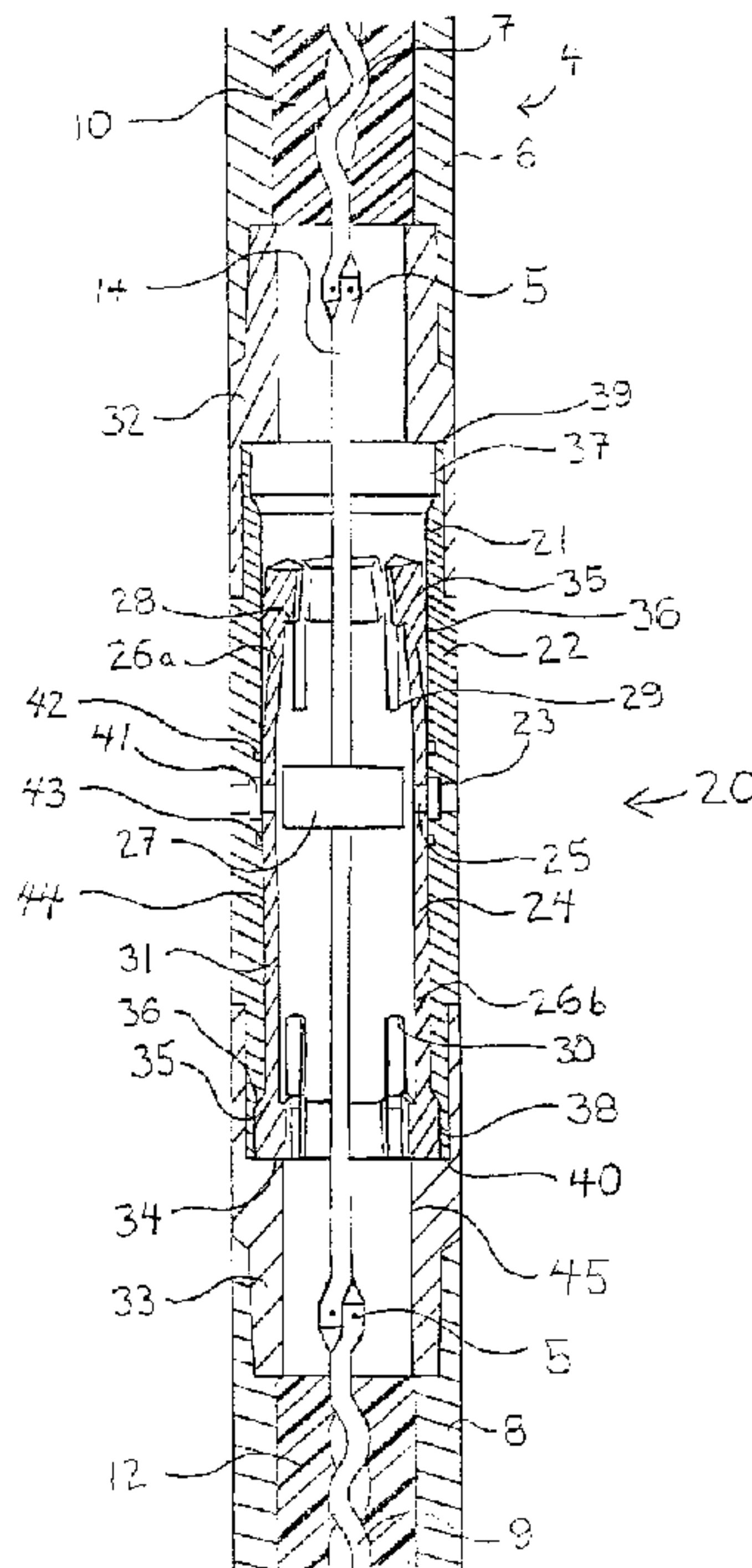

(22) Date de dépôt/Filing Date: 1998/08/07
(41) Mise à la disp. pub./Open to Public Insp.: 2000/02/07
(45) Date de délivrance/Issue Date: 2002/01/15

(51) Cl.Int.⁶/Int.Cl.⁶ E21B 43/12, E21B 43/38, F04D 29/70, F04B 47/06, F04D 3/02
(72) Inventeur/Inventor: CARRIERE, Kent J., CA
(73) Propriétaire/Owner: CARRIERE, Kent J., CA
(74) Agent: AIKINS, MACAULAY & THORVALDSON

(54) Titre : OUTIL DU TYPE POMPE ROTATIVE A VIS A DEUX PHASES ET PROCEDE POUR VIDANGER AVEC LADITE POMPE
(54) Title: DUAL STAGE ROTARY SCREW PUMP TOOL AND METHOD OF PUMP FLUSHING



(57) **Abrégé/Abstract:**

A rotary pump coupling device is used for flushing dual rotary screw pumps. The device is in the form of a tubular housing having a first set of apertures and a pair of subs for connecting the device to the stators of upper and lower pumps of an oil production string. Within the housing is a sleeve having a second set of apertures. The sleeve is slidable between an open position when the first and second set of apertures communicate and a closed position when the first and second set of apertures do not communicate. Fingers extend from a top and bottom end of the sleeve. Protrusions extending radially outward from the fingers are received in respective upper and lower annular recesses along an inner face of the housing in open or closed positions. Camming faces on the protrusions disengage the protrusions from the upper and lower recesses when the sleeve is displaced from the open or closed positions. A collar mounted on a drive shaft connecting the upper and lower pumps engages shoulders on an inner face of the sleeve for displacing the sleeve between open or closed positions.

ABSTRACT

A rotary pump coupling device is used for flushing dual rotary screw pumps. The device is in the form of a tubular housing having a first set of apertures and a pair of subs for connecting the device to the stators of upper and lower pumps
5 of an oil production string. Within the housing is a sleeve having a second set of apertures. The sleeve is slidable between an open position when the first and second set of apertures communicate and a closed position when the first and second set of apertures do not communicate. Fingers extend from a top and bottom end of the sleeve. Protrusions extending radially outward from the fingers are received in
10 respective upper and lower annular recesses along an inner face of the housing in open or closed positions. Camming faces on the protrusions disengage the protrusions from the upper and lower recesses when the sleeve is displaced from the open or closed positions. A collar mounted on a drive shaft connecting the upper and lower pumps engages shoulders on an inner face of the sleeve for displacing the
15 sleeve between open or closed positions.

DUAL STAGE ROTARY SCREW PUMP TOOL AND METHOD OF PUMP FLUSHING

FIELD OF THE INVENTION

The present invention relates to oil product, and particularly to the
5 flushing of sand in dual rotary screw pumps.

BACKGROUND

Dual stage screw pumps are used in heavy oil wells. Conventionally
there is a bottom screw pump and a top screw pump connected by a three foot long
perforated pup joint. The bottom screw pump pumps oil from the bottom of the well
10 up to the perforated pup joint and circulates out the holes and back down to the
bottom of the well. Meanwhile, the top pump takes a portion of the oil in the pup joint
and brings it to the surface. When the pumps become clogged with sand, it is
required to bring in a flush-by unit that pumps oil and water down to move the sand
out of the pumps. With this process the flush-by does not reach the bottom pump as
15 all the fluid is forced out the holes in the perforated pup joint and the bottom pump
remains clogged with sand. In order to clear the bottom pump of sand, a service rig
must pull up the entire string of rods and pump rotors. This is an expensive and time
consuming procedure that is preferably avoided.

SUMMARY

20 According to one aspect of the invention there is provided a device for
use in conjunction with a dual rotary screw pump system having an upper pump and a
lower pump, each having a stator and a rotor, and a drive shaft connecting the rotors,
the device comprising:

a tubular housing having first aperture means therethrough;

25 a sleeve having second aperture means therethrough, the sleeve being
slideable within the housing between an open position with the second aperture

- 2 -

means communicating with the first aperture means and a closed position with the first and second aperture means out of communication with one another;

displacement means for displacing the sleeve within the housing between the open and closed positions; and

5 connection means for connecting the housing to the stators of the upper and lower pumps.

Preferably the displacement means is in the form of a collar fixed to the drive shaft connecting the upper and lower pump rotors for engaging shoulders on the inner face of the sleeve adjacent to the top and bottom ends.

10 The device is preferably connected to the stators of the upper and lower pumps with subs. The sub connecting the top of the device has a shoulder along its inner face for engaging the top end of the sleeve when the device is in the closed position. The sub connecting the bottom of the device has a shoulder along its inner
15 position.

It is also preferred that the sleeve include resilient fingers extending from the top and bottom ends of the sleeve. At the ends of the fingers, there are protrusions extending radially outward. The housing has an upper annular recess in the inner face at the top end for receiving the protrusions of the top fingers when the
20 device is in one of the open and closed positions. The housing also has a lower annular recess in the inner face at the bottom end for receiving the protrusions of the bottom fingers when the device is in the other of the open and closed positions. When the protrusions are not aligned with the respective recess, the fingers are flexed inwardly to allow the protrusions to travel along the inner surface of the housing.

25 In the preferred embodiment the protrusions of the top fingers have camming faces for disengaging the protrusions from the upper recess when the

- 4 -

top fingers extending along the sleeve at a top end of the sleeve;
bottom fingers extending along the sleeve at a bottom end of the sleeve;

5 protrusions on the top fingers and bottom fingers extending radially outward from the sleeve for selective engagement in the upper and lower annular recesses respectively;

camming faces on the protrusions for disengaging the protrusions from the upper and lower recess in response to displacement of the sleeve along the housing; and

10 spaced upper and lower shoulders on an inner face of the sleeve;

a first seal above the central recess and a second seal below the central recess, the first and second seals sealing the inner face of the housing to an outer face of the sleeve for sealing the central recess;

displacement means for displacing the sleeve between an open position
15 with the second set of apertures communicating with the first set of apertures and the protrusions on one of the top and bottom fingers engaged in one of the upper and lower annular recesses in the housing respectively, and a closed position with the first and second set of apertures out of communication and the protrusions on the other of the top and bottom fingers engaged in the other of the upper and lower annular
20 recesses in the housing respectively, the displacement means comprising a collar fixed to the drive shaft for engaging the upper and lower shoulders on the sleeve for moving the sleeve between the open and closed positions in response to movement of the sleeve along the housing; and

first and second subs for connecting the housing to stators of the upper
25 and lower pumps, the first sub having a shoulder for engaging the top end of the sleeve when the device is in one of the open or closed positions and the second sub

- 5 -

having a shoulder for engaging the bottom end of the sleeve when the device is in the other of the open and closed positions.

According to a further aspect of the present invention there is provided a method for flushing a dual rotary screw pump system including an upper pump and a lower pump, each having a stator and a rotor, a drive shaft connecting the rotors, and
5 a tubular housing connecting the stators, the housing having at aperture means therethrough, said method comprising:

injecting flushing fluid into and through the upper pump and out of the aperture means to flush the upper pump;

10 closing the aperture means; and

injecting flushing fluid into the upper pump and through the upper and lower pumps to flush the lower pump.

BRIEF DESCRIPTION OF THE DRAWINGS

In the accompanying drawings, which illustrate an exemplary
15 embodiment of the present invention:

Figure 1 is a longitudinal cross-section of the device in an open position as it is installed within an oil production string;

Figure 2 is a longitudinal cross-section of the device in a closed position;
and

20 Figure 3 is an exploded isometric view of the device and its components.

DETAILED DESCRIPTION

Referring to Figure 1, the device 20 of the present invention is for use with an oil production string 4. It is particularly for use with a production string 4
25 having dual stage screw pumps comprising an upper pump 10 and a lower pump 12. The upper pump 10 is a screw type pump having a stator 6 and a rotor 7 rotatable

- 6 -

therein. The lower pump 12 is also a screw type pump having a stator 8 and a rotor 9 rotatable therein. The top rotor 7 is connected to the bottom rotor 9 through a drive shaft 14 with universal joints 5 located at both ends of the drive shaft. The device 20 replaces a perforated pup joint which otherwise connects the upper pump 10 to the lower pump 12.

Referring to Figures 1, 2 and 3, the device 20 includes a main tubular housing 22 having an inner face 21, a top end 39, a bottom end 40 and a first set of apertures 23 circumferentially spaced about the mid-section of the housing 22. Within the housing 22 is a sleeve 24 shorter in length than the housing 22 and slideable therein.

The sleeve 24 has a second set of apertures 25 circumferentially spaced about the mid-section of the sleeve 24. Resilient top fingers 26a extend from a top end 29 of the sleeve 24 and resilient bottom fingers 26b extend from a bottom end 30 of the sleeve. The fingers 26a and 26b have protrusions 35 extending radially outward at the free ends of the fingers. Inner first shoulders 28 are located along an inner face 31 of the fingers adjacent to the free ends.

The housing 22 of the device 20 is connected to the upper and lower pump stators 6, 8 by upper and lower subs 32, 33 threaded to the respective upper and lower stators 6, 8. The first and second subs, 32 and 33 each have an internal second shoulder 34 on an inner face 45 of the sub.

The first set of apertures 23 of the housing 22 communicate with a central annular recess 25 around the inner face 21 of the housing 22. The recess 25 is sealed by a first seal 42 above the port and a second seal 43 below the port. The first seal 42 and the second seal 43 are set into grooves in the inner face 21 of the housing 22 and engage the outer face 44 of the sleeve 24.

The device 20 is in an open position when the second set of apertures

- 7 -

25 communicates with the first set of apertures 23 and the bottom fingers 26b are engaged with the second shoulder 34 of the second sub 33 as shown in Figure 1. The device is in a closed position when the first and second set of apertures 23, 25 are not communicating and the top fingers 26a are engaged with the second shoulder
5 34 of the first sub 32 as shown in Figure 2.

The housing 22 has an upper annular recess 37 at the upper end 39 of the inner face 21 of the housing 22 and a lower annular recess 38 at the lower end 40 of the inner face 21 of the housing 22. The upper annular recess 37 receives the protrusions 35 of the top fingers 26a when the device is in the closed position and the
10 lower annular recess 38 receives the protrusions 35 of the bottom fingers 26b when the device is in the open position.

The protrusions 35 of the top fingers 26a have camming faces 36 for disengaging the protrusions from the upper recess 37 when the device is displaced from the closed position. The protrusions 35 of the bottom fingers 26b have camming
15 faces 36 for disengaging the protrusions from the lower recess 38 when the device is displaced from the open position.

As the camming faces 36 disengage the protrusions 35 of the top fingers 26a and the bottom fingers 26b from their respective recesses 37, 38 the fingers 26 are forcibly flexed inwardly. The fingers 26 remain flexed inwardly as the
20 device 20 is in the process of being opened or closed while the protrusions 35 travel along the inner face 21 of the housing 22.

The drive shaft 14 passing through the centre of the tubular housing 22 includes a collar 27 which is fixed to the drive shaft 14 for engaging the first shoulders 28 on the inner face 31 of the fingers 26 when the fingers are flexed inwards. The
25 collar 27 engages the first shoulders 28 of the top fingers 26a when the sleeve 24 is displaced from the open position by pulling the drive shaft 14 upwards. The collar 27

- 8 -

engages the second shoulders 328 of the bottom fingers 26b when the sleeve 24 is displaced from the closed position by allowing the drive shaft 14 to drop downwards.

With the device 20 in the open position as in Figure 1, the oil production string 4 may be used for regular production as the device 20 acts as the perforated pup joint which it replaces. When the pumps become clogged the upper pump 10 may be flushed with oil and water with the device remaining in the open position shown in Figure 1. When the upper pump 10 is cleared, the device 20 may be closed as shown in Figure 2 and then the flushing of oil and water is forced through the lower pump 12. The removal of clogged sand is accomplished while the production string remains in the ground.

Since various modifications can be made in my invention as herein above described, and many apparently widely different embodiments of same made within the spirit and scope of the claims without departure from such spirit and scope, it is intended that all matter contained in the accompanying specification shall be interpreted as illustrative only and not in a limiting sense.

While one embodiment of the present invention has been described in the foregoing, it is to be understood that other embodiments are possible within the scope of the invention. The invention is to be considered limited solely by the scope of the appended claims.

CLAIMS

1. A device for use in conjunction with a dual rotary screw pump system having an upper pump and a lower pump, each having a stator and a rotor, and a drive shaft connecting the rotors, the device comprising:
- 5 a tubular housing having first aperture means therethrough;
a sleeve having second aperture means therethrough, the sleeve being slideable within the housing between an open position with the second aperture means communicating with the first aperture means and a closed position with the first and second aperture means out of communication with one another;
- 10 displacement means for displacing the sleeve within the housing between the open and closed positions; and
connection means for connecting the housing to the stators of the upper and lower pumps.
2. The device of claim 1 wherein the displacement means comprises
15 spaced apart upper and lower shoulders on an inner face of the sleeve and a collar fixed to the drive shaft for engaging the upper and lower shoulders for displacing the sleeve between the closed and open positions in response to movement of the drive shaft along the housing.
3. The device of claim 1 or 2 wherein the connection means comprises first
20 and second subs for connecting the device to the stators of the upper and lower pumps.
4. The device of claim 3 wherein the first sub has an inner face and a shoulder on the inner face for engaging the sleeve when the device is in the closed position and the second sub has an inner face and a shoulder on the inner face for
25 engaging the sleeve when the device is in the open position.
5. The device of claim 1, 2, 3 or 4 wherein the sleeve includes a plurality of

- 10 -

top fingers extending along the sleeve at a top end of the sleeve and a plurality of bottom fingers extending along the sleeve at a bottom end of the sleeve, the fingers comprising protrusions extending radially outwardly from the sleeve.

6. The device of claim 5 wherein the housing has an upper annular recess in an inner face of the housing for receiving the protrusions of the top fingers when the device is in one of the open and closed positions and a lower annular recess in an inner face of the housing for receiving the protrusions of the bottom fingers when the device is in the other of the open and closed positions.

7. The device of claim 6 wherein the protrusions of the top fingers have camming faces for disengaging the protrusions from the upper recess when the device is displaced from said one of the open and closed positions and the protrusions of the bottom fingers have camming faces for disengaging the protrusions from the lower recess when the device is displaced from said other of the open and closed positions.

8. The device of any one of claims 1 to 5 including a central annular recess in an inner face of the housing in communication with the first set of apertures, a first seal above the recess and a second seal below the recess, for sealing the inner face of the housing to an outer face of the sleeve to seal the central recess.

9. The device of claim 6 or 7 including a central annular recess in the inner face of the housing in communication with the first set of apertures, a first seal above the recess and a second seal below the recess for sealing the inner face of the housing to an outer face of the sleeve to seal the central recess.

10. The device of any one of claims 1 to 9 wherein each of the first and second aperture means comprises a set of apertures.

11. A device for use in conjunction with a dual rotary screw pump system including an upper pump and a lower pump, each having a stator and a rotor, and a

- 11 -

drive shaft connecting the rotors, the device comprising:

a tubular housing having:

an inner face;

a first set of apertures therethrough;

5 an upper annular recess in the inner face of the housing adjacent
a top end of the housing;

a lower annular recess in the inner face of the housing adjacent a
bottom end of the housing; and

a central annular recess around the inner face of the housing in
10 communication with the first set of apertures;

a sleeve shorter in length than the housing and mounted in the housing
to slide therealong, the sleeve having:

a second set of apertures therethrough;

top fingers extending along the sleeve at a top end of the sleeve;

15 bottom fingers extending along the sleeve at a bottom end of the
sleeve;

protrusions on the top fingers and bottom fingers extending
radially outward from the sleeve for selective engagement in the upper and lower
annular recesses respectively;

20 camming faces on the protrusions for disengaging the protrusions
from the upper and lower recess in response to displacement of the sleeve along the
housing; and

spaced upper and lower shoulders on an inner face of the sleeve;

a first seal above the central recess and a second seal below the central
25 recess, the first and second seals sealing the inner face of the housing to an outer
face of the sleeve for sealing the central recess;

- 12 -

displacement means for displacing the sleeve between an open position with the second set of apertures communicating with the first set of apertures and the protrusions on one of the top and bottom fingers engaged in one of the upper and lower annular recesses in the housing respectively, and a closed position with the first and second set of apertures out of communication and the protrusions on the other of the top and bottom fingers engaged in the other of the upper and lower annular recesses in the housing respectively, the displacement means comprising a collar fixed to the drive shaft for engaging the upper and lower shoulders on the sleeve for moving the sleeve between the open and closed positions in response to movement of the sleeve along the housing; and

first and second subs for connecting the housing to stators of the upper and lower pumps, the first sub having a shoulder for engaging the top end of the sleeve when the device is in one of the open or closed positions and the second sub having a shoulder for engaging the bottom end of the sleeve when the device is in the other of the open and closed positions.

12. A method for flushing a dual rotary screw pump system including an upper pump and a lower pump, each having a stator and a rotor, a drive shaft connecting the rotors, and a tubular housing connecting the stators, the housing having at aperture means therethrough, said method comprising:

injecting flushing fluid into and through the upper pump and out of the aperture means to flush the upper pump;

closing the aperture means; and

injecting flushing fluid into the upper pump and through the upper and lower pumps to flush the lower pump.

Figure 2

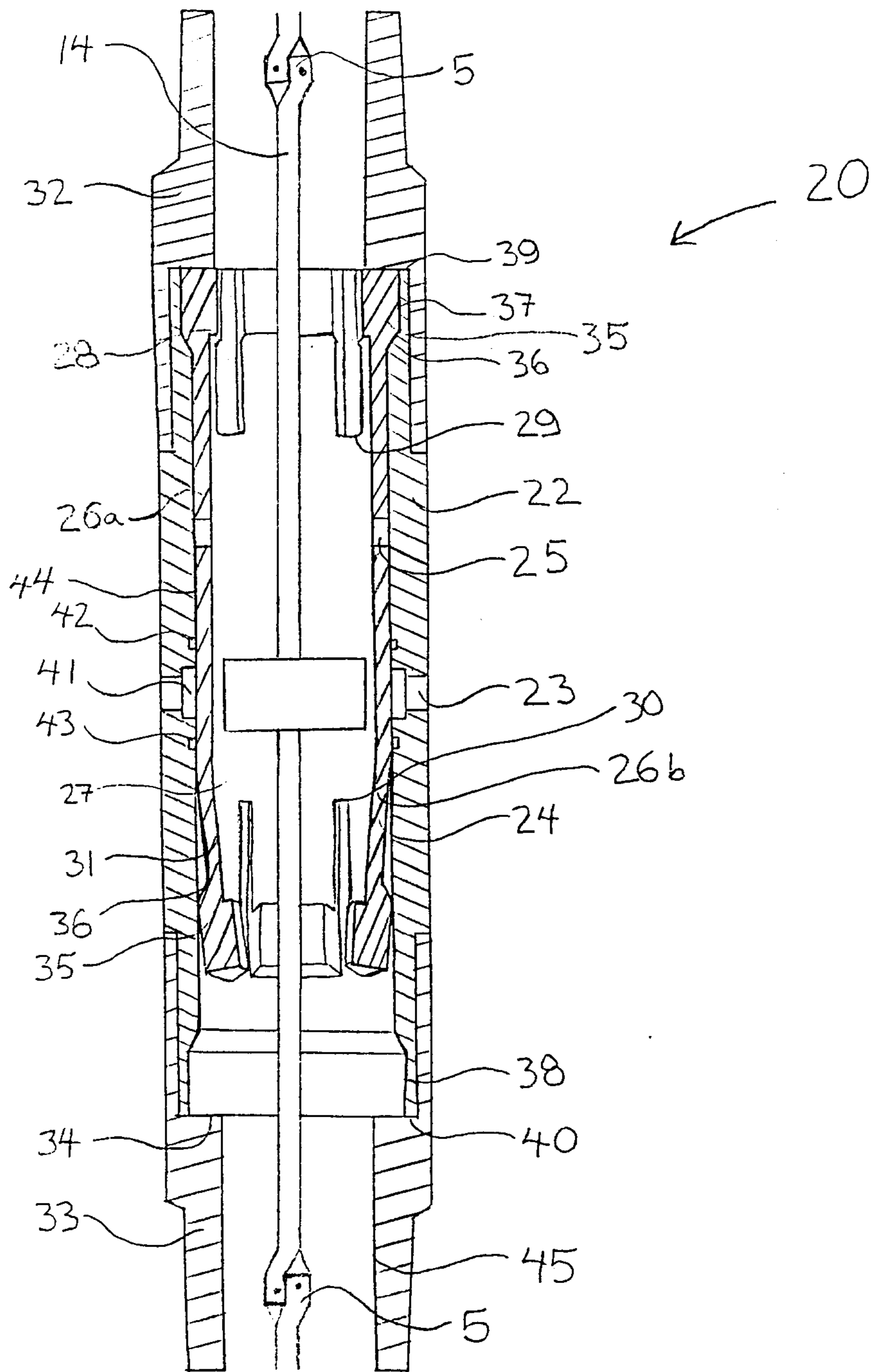

INVENTOR: KENT J. CARRIERE
By: ADE & COMPANY

Figure 3

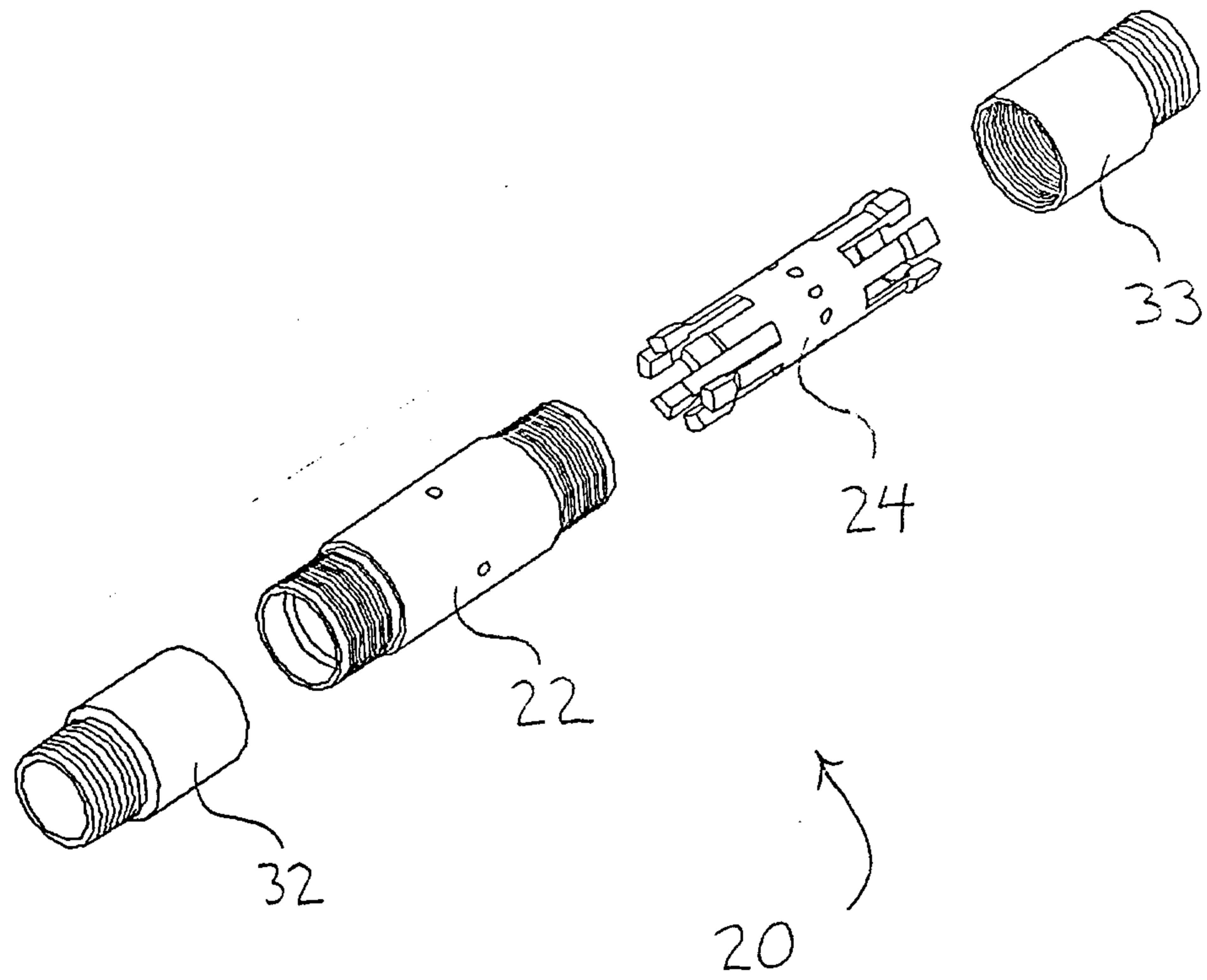

INVENTOR: KENT J. CARRIERE
By: ADE & COMPANY

