

(19) World Intellectual Property Organization
International Bureau



(43) International Publication Date
20 February 2003 (20.02.2003)

PCT

(10) International Publication Number
WO 03/014342 A2

(51) International Patent Classification⁷: C12N 15/00

(21) International Application Number: PCT/EP02/08963

(22) International Filing Date: 9 August 2002 (09.08.2002)

(25) Filing Language: English

(26) Publication Language: English

(30) Priority Data:

01119377.8	10 August 2001 (10.08.2001)	EP
01119528.6	14 August 2001 (14.08.2001)	EP
60/315,955	31 August 2001 (31.08.2001)	US

(71) Applicant (for all designated States except US): NATIONAL PUBLIC HEALTH INSTITUTE [FI/FI]; Mannerheimintie 166, FIN-00300 Helsinki (FI).

(72) Inventors; and

(75) Inventors/Applicants (for US only): PELTONEN, Leena [FI/FI]; National Public Health Institute, Biomedicum Dept of Molecular Medicine, Haartmaninkatu 8, 00251 Helsinki (FI). ENATTAH, Nabil [LY/FI]; National Public Health Institute, Biomedicum, Dept of Molecular Medicine, Haartmaninkatu 8, 00251 Helsinki (FI). JÄRVELÄ, Irma [FI/FI]; National Public Health Institute, Biomedicum Dept of Molecular Medicine, Haartmaninkatu 8, 00251 Helsinki (FI). SAHI, Timo [FI/FI]; Finnish Defence Forces, P.O.Box 919, 00131 Helsinki (FI). SAVILAHTI, Erkki [FI/FI]; Hospital for Children and Adolescents,

P.O.Box 281, 00029 Hus (FI). TERWILLIGER, Joseph [US/US]; Columbia University, Department of Psychiatry and, Columbia Genome Center, 1150 St. Nicholas Avenue, New York, NY 10032 (US).

(74) Agent: VOSSIUS & PARTNER; Siebertstrasse 4, 81675 Munich (DE).

(81) Designated States (national): AE, AG, AL, AM, AT, AU, AZ, BA, BB, BG, BR, BY, BZ, CA, CH, CN, CO, CR, CU, CZ, DE, DK, DM, DZ, EC, EE, ES, FI, GB, GD, GE, GH, GM, HR, HU, ID, IL, IN, IS, JP, KE, KG, KP, KR, KZ, LC, LK, LR, LS, LT, LU, LV, MA, MD, MG, MK, MN, MW, MX, MZ, NO, NZ, OM, PH, PL, PT, RO, RU, SD, SE, SG, SI, SK, SL, TJ, TM, TN, TR, TT, TZ, UA, UG, US, UZ, VC, VN, YU, ZA, ZM, ZW.

(84) Designated States (regional): ARIPO patent (GH, GM, KE, LS, MW, MZ, SD, SL, SZ, TZ, UG, ZM, ZW), Eurasian patent (AM, AZ, BY, KG, KZ, MD, RU, TJ, TM), European patent (AT, BE, BG, CH, CY, CZ, DE, DK, EE, ES, FI, FR, GB, GR, IE, IT, LU, MC, NL, PT, SE, SK, TR), OAPI patent (BF, BJ, CF, CG, CI, CM, GA, GN, GQ, GW, ML, MR, NE, SN, TD, TG).

Published:

— without international search report and to be republished upon receipt of that report

For two-letter codes and other abbreviations, refer to the "Guidance Notes on Codes and Abbreviations" appearing at the beginning of each regular issue of the PCT Gazette.

(54) Title: IDENTIFICATION OF A DNA VARIANT ASSOCIATED WITH ADULT TYPE HYPOLACTASIA

(57) Abstract: The present invention relates to a nucleic acid molecule comprising a 5' portion of an intestinal lactase-phlorizine hydrolase (LPH) gene contributing to or indicative of the adult-type hypolactasia wherein said nucleic acid molecule is selected from the group consisting of (a) a nucleic acid molecule having or comprising the nucleic acid sequence of SEQ ID NO: 1, the sequence of SEQ ID NO:1 is also depicted in the Fig. 4 and comprised in the sequence as depicted in the Fig. 8; (b) a nucleic acid molecule having or comprising the nucleic acid sequence of SEQ ID NO: 2, the sequence of SEQ ID NO:2 is also depicted in Fig.5 and comprised in the sequence as depicted in the Fig. 9; (c) a nucleic acid molecule of at least 20 nucleotides the complementary strand of which hybridizes under stringent conditions to the nucleic acid molecule of (a) or (b), wherein said polynucleotide/nucleic acid molecule has at a position corresponding to position -13910 5' from the LPH gene a cytosine residue; and (d) a nucleic acid molecule of at least 20 nucleotides the complementary strand of which hybridizes under stringent conditions to the nucleic acid molecule of (a) or (b), wherein said polynucleotide/nucleic acid molecule has at a position corresponding to position -22018 5' from the LPH gene a guanine residue. The present invention further relates to methods for testing for the presence of or predisposition to adult-type hypolactasia that are based on the analysis of an SNP contained in the above recited nucleic acid molecule. Additionally, the present invention relates to diagnostic composition and kit useful in the detection of the presence of or predisposition to adult-type hypolactasia.



WO 03/014342 A2

Identification of a DNA variant associated with adult type hypolactasia

5 The present invention relates to a nucleic acid molecule comprising a 5' portion of an intestinal lactase-phlorizine hydrolase (LPH) gene contributing to or indicative of the adult-type hypolactasia wherein said nucleic acid molecule is selected from the group consisting of (a) a nucleic acid molecule having or comprising the nucleic acid sequence of SEQ ID NO: 1, the sequence of SEQ ID NO:1 is also depicted in Fig. 4
10 and comprised in the sequence as depicted in Fig. 8; (b) a nucleic acid molecule having or comprising the nucleic acid sequence of SEQ ID NO: 2, the sequence of SEQ ID NO:2 is also depicted in Fig. 5 and comprised in the sequence as depicted in Fig. 9; (c) a nucleic acid molecule of at least 20 nucleotides the complementary strand of which hybridizes under stringent conditions to the nucleic acid molecule of
15 (a) or (b), wherein said polynucleotide/nucleic acid molecule has at a position corresponding to position -13910 5' from the LPH gene a cytosine residue; and (d) a nucleic acid molecule of at least 20 nucleotides the complementary strand of which hybridizes under stringent conditions to the nucleic acid molecule of (a) or (b), wherein said polynucleotide/nucleic acid molecule has at a position corresponding to
20 position -22018 5' from the LPH gene a guanine residue. The present invention further relates to methods for testing for the presence of or predisposition to adult-type hypolactasia that are based on the analysis of an SNP contained in the above recited nucleic acid molecule. Additionally, the present invention relates to diagnostic composition and kit useful in the detection of the presence of or predisposition to
25 adult-type hypolactasia.

A variety of documents is cited throughout this specification. The disclosure content of these documents, including manufacturer's manuals and catalogues, is herewith incorporated by reference.

30

Lactase-phlorizin hydrolase enzyme (LPH), which is exclusively expressed by intestinal epithelial cells, hydrolyses lactose, sugar of milk, into glucose and galactose¹. The expression of the LPH enzyme dramatically declines to very low

levels at the weaning period in mammals when lactose is no longer an essential part of the diet. In humans, the condition known as adult-type hypolactasia or lactase non-persistence, affects most populations and severely limits the use of fresh milk among adults due to lactose intolerance. The age of onset of lactase non-persistence status varies between populations, ranging from 1-2 years of age among the Thais to 10-20 years of age among the Finns²⁻³. However, in Northern European and a few other ethnic groups, LPH activity persists throughout life in the majority of adults, a condition known as lactase persistence. The phenotype lactase persistence/non-persistence has been shown to be genetically determined, the persistent status being dominant over the non-persistent status⁴⁻⁶.

The state of the art diagnosis of adult-type hypolactasia is based on the lactose tolerance test (LTT). After overnight fasting (10 hours), 1g/kg of lactose is given as a 12.5% solution, the maximum dose being 50g. Capillary blood samples are taken before and 20 and 30 min after lactose ingestion. The glucose concentration is determined by the glucose oxidase method (Hjelm and de Verdier 1963). Abdominal symptoms on the day of LTT are noted. A maximum rise in blood glucose concentration of 1.1 mmol/l or more was taken as a sign of lactose malabsorption (Gudman-Hoyer and Harnum 1968, Jussila 1970, Sahi 1972). LTT contains a 10% risk for false positive and negative diagnoses, i.e. the sensitivity and specificity of LTT is about 90% (Isokoski et al. 1972, Newcomer et al. 1975, Sahi 1983).

The accuracy of LTT can be improved by giving 0.3 g/kg ethanol that inhibits the metabolism of galactose in the liver (Tygstrup and Lundqvist 1962) and 15 min later 1g/kg lactose as 12.5% solution.

Children with maximum rises of less than 0.2mg/100ml in the first or repeated LTT have been sent for small-intestinal biopsy that is taken through gastroscopy. This is an invasive procedure that needs expertise and is usually performed at university hospitals by specialists in gastroenterology only. Biopsy samples are examined with a dissection microscope and histologically, and the mucosal maltase, sucrase and lactase activities are determined (Launiala et al. 1964). The diagnosis of hypolactasia in children is justified if the histology of the intestinal biopsy is normal and lactase activity is less than 20U/g protein and lactase/sucrase ratio less than 0.30, or in the

LTT with ethanol administration a maximum rise in blood glucose concentration of less than 20mg/100ml and in galactose concentration of 5mg/100 ml or less (Sahi et al, 1972) is demonstrated. As described above, the current methods to diagnose adult-type hypolactasia are laborious. LTT is inexact and therefore, an invasive
5 procedure, gastroscopy is needed before the diagnosis can be ascertained. Since adult-type hypolactasia is very common and the major cause of nonspecific abdominal symptoms (in one third of patients complaining stomach pain), there is a clear need to improve the diagnostics of this common health problem.

10 Yet, so far no biochemical test that is easy to handle and, at the same time, provides quick and accurate results has been developed. Elucidation of the cause of the disease on the genomic DNA/ expression level has equally been unsuccessful. Thus, the sequencing of the coding and promoter regions of the LPH gene in adults has revealed no DNA-variations which correlate with lactase persistence/ non-
15 persistence, nor has evidence emerged of splice variants or mRNA editing variants associated with this trait⁷⁻⁸. Previous studies have shown that the lactase persistence/non-persistence trait is possibly controlled by cis-acting element(s) residing within or adjacent to the lactase gene, and strong linkage disequilibrium (LD) has been observed across the 70 kb haplotype spanning the lactase gene^{9,10}.
20 Several studies report evidence that the main control of the LPH gene expression operates at the level of transcription regulation¹¹⁻¹³. However, it has been suggested that variation influencing both transcriptional and posttranscriptional control of expression of the LPH gene may be involved in the etiology of adult-type hypolactasia¹⁴⁻¹⁵.

25

In view of the above, the technical problem underlying the present invention was to provide means and methods that allow for an accurate and convenient diagnosis of adult-type hypolactasia or of a predisposition to this disease.

30 The solution to said technical problem is achieved by the embodiments characterized in the claims.

Thus, the present invention relates to a nucleic acid molecule comprising a 5' portion

of an intestinal lactase-phlorizine hydrolase (LPH) gene contributing to or indicative of adult-type hypolactasia wherein said nucleic acid molecule is selected from the group consisting of (a) a nucleic acid molecule having or comprising the nucleic acid sequence of SEQ ID NO: 1, the sequence of SEQ ID NO:1 is also depicted in Fig. 4
5 and comprised in the sequence as depicted in Fig. 8; (b) a nucleic acid molecule having or comprising the nucleic acid sequence of SEQ ID NO: 2, the sequence of SEQ ID NO:2 is also as depicted in Fig. 5 and comprised in the sequence as depicted in Fig. 9; (c) a nucleic acid molecule of at least 20 nucleotides the complementary strand of which hybridizes under stringent conditions to the nucleic acid molecule of (a) or (b), wherein said polynucleotide/nucleic acid molecule has at
10 a position corresponding to position -13910 5' from the LPH gene a cytosine residue; and (d) a nucleic acid molecule of at least 20 nucleotides the complementary strand of which hybridizes under stringent conditions to the nucleic acid molecule of (a) or (b), wherein said polynucleotide/nucleic acid molecule has at a position
15 corresponding to position -22018 5' from the LPH gene a guanine residue.

In accordance with the invention, the term "intestinal lactase-phlorizine hydrolase (LPH) gene" denotes a gene that encodes an enzyme having the activity of hydrolyzing lactose into its components glucose and galactose. The enzyme is
20 characterized by E.C. 3.2.1.23.62.

The term "adult-type hypolactasia" refers to a condition also known as lactose intolerance, which is an autosomal recessive condition resulting from the "physiological" decline of the lactase-phlorizin hydrolase (LPH) enzyme activity in
25 intestinal cells in a significant proportion of the global population.

The term "contributing to or indicative of adult-type hypolactasia", refers to the fact that the SNPs and thus the corresponding nucleic acid molecules found are indicative of the condition and possibly also causative therefore. Accordingly, this
30 term necessarily requires that the recited 5' position is indicative of the condition. Said term, on the other hand, does not necessarily require that the 5' portion is causative or contributes to the condition. Yet, said term does not exclude a causative or contributory role of either or both SNPs.

The term "which hybridizes under stringent conditions" refers to hybridization conditions that are well known to or can be established by the person skilled in the art according to conventional protocols. The term most advantageously refers to highly stringent conditions. Appropriate stringent conditions for each sequence may be established on the basis of well-known parameters such as temperature, composition of the nucleic acid molecules, salt conditions etc.: see, for example, Sambrook et al., "Molecular Cloning, A Laboratory Manual"; CSH Press, Cold Spring Harbor, 1989 or Higgins and Hames (eds.), "Nucleic acid hybridization, a practical approach", IRL Press, Oxford 1985 (reference 54), see in particular the chapter "Hybridization Strategy" by Britten & Davidson, 3 to 15. Typical (highly stringent) conditions comprise hybridization at 65°C in 0.5xSSC and 0.1% SDS or hybridization at 42°C in 50% formamide, 4xSSC and 0.1% SDS. Hybridization is usually followed by washing to remove unspecific signal. Washing conditions include conditions such as 65°C, 0.2xSSC and 0.1% SDS or 2xSSC and 0,1% SDS or 0,3XSSC and 0,1% SDS at 25°C – 65°C.

As disclosed herein above, the present invention also relates to a hybridizing nucleic acid molecules of at least 20 nucleotides; see (c) and (d) herein above. Yet, the present invention also relates to a nucleic acid molecule of at least 50, at least 100, at least 150, or at least 200 nucleotides. Preferably, said hybridizing fragments comprise at least 25, at least 50, or at least 75 nucleotides, at least 100 nucleotides, 5' and 3' of the position –13910 as defined in (c) or of position –22018 ad defined in (d) herein above.

25

The term "nucleic acid molecule" refers both to naturally and non-naturally occurring nucleic acid molecules. Non-naturally occurring nucleic acid molecules include cDNA as well as derivatives such as PNA.

30 The term "nucleic acid molecule [...] comprising the nucleic acid sequence of SEQ ID NO:" throughout this specification refers to nucleic acid molecules that are at least 1 nucleotide longer than the nucleic acid molecule specified by the SEQ ID NO. At the same time, these nucleic acid molecules extend, at a maximum, 30000 nucleotides

over the 5' and/or 3' end of the nucleic acid molecule of the invention specified e.g. by the SEQ ID NO: 2 or 1, 3 or 4.

Surprisingly, it was found in accordance with the present invention that the two
5 hypolactasia-associated variants locate at a considerable distance from the LPH
gene, positioned in different introns of the *MCM6* gene. *MCM6* is a member of a
gene family (*MCM 2-7*), required for the initiation of DNA replication ensuring that it
takes place only once during the cell cycle³¹. *MCM6*, unlike *LPH*, is not restricted in
its tissue distribution and there is no correlation in the levels of *MCM6* and *LPH*
10 transcripts¹⁸. These findings would suggest that these two genes do not share any
functionally significant cis-acting elements providing tissue specificity or
developmental regulation¹⁸. Most probably the identified variants have different
functional significance for the expression of the *LPH* and *MCM6* genes. Further
surprisingly, based on complete association to hypolactasia they (or one of them) are
15 associated to age-dependent down regulation of the transcript level of the *LPH* gene
in the intestinal epithelium but have little or no effect on the transcription of the
MCM6.

Experimentally, using linkage, allelic association and extended haplotype analysis
20 carried out in nine extended Finnish families the adult-type hypolactasia locus was
restricted to a 47 kb interval on 2q21. The sequence analysis of the region revealed a
single nucleotide polymorphism (SNP), C/T-13910 that completely cosegregated with
adult-type hypolactasia in all Finnish families and in a sample set of 236 individuals
from four different populations. Another SNP G/A-22018 residing 8 kb telomeric from
25 C/T -13910 was associated with the trait in all but 7 cases. The prevalence of C/T -
13910 SNP in 1047 DNA samples reflected the reported prevalence of adult-type
hypolactasia in three different populations providing additional evidence for its
importance for the trait.

30 The surprising finding referred to above for the first time allows the establishment of
test systems that are based on the molecular analysis of the recited single nucleotide
polymorphisms upstream of the LPH gene. Whereas both SNPs provide for a solid
basis for the diagnosis of or the diagnosis of a predisposition to adult-type

hypolactasia, it is preferred that the nucleotide position -13910 is analyzed, either alone or in combination with nucleotide position -22018. This is because the SNP at position -13910 was associated in 100% of the analysed cases with the disease whereas the SNP at position -22018 was associated in only 98% of all cases with adult-type hypolactasia. Nevertheless, analyses of nucleotide position -22018 alone will usually also provide a sound basis for a diagnosis of a predisposition to adult-type hypolactasia.

Due to the abundance of established methods for assessing for the presence of SNPs, it is now possible to conveniently, in a short amount of time, at low cost, with high accuracy and without significant trouble for the person under investigation, diagnose a genetic predisposition to adult-type hypolactasia.

The invention further relates to a nucleic acid molecule comprising a 5' portion of an intestinal lactase-phlorizine hydrolase (LPH) gene wherein said nucleic acid molecule is selected from the group consisting of (a) a nucleic acid molecule having or comprising the nucleic acid sequence of SEQ ID NO:3, the sequence of SEQ ID NO:3 is also depicted in Fig. 6; (b) a nucleic acid molecule having or comprising the nucleic acid sequence of SEQ ID NO:4, the sequence of SEQ ID NO:4 is also depicted in Fig. 7; (c) a nucleic acid molecule the complementary strand of which hybridizes under stringent conditions to the nucleic acid molecule of (a) or (b), wherein said polynucleotide/nucleic acid molecule has at a position corresponding to position -13910 of the LPH gene a thymidine residue; and (d) a nucleic acid molecule the complementary strand of which hybridizes under stringent conditions to the nucleic acid molecule of (a) or (b), wherein said polynucleotide/nucleic acid molecule has at a position corresponding to position -22018 of the LPH gene a adenosine residue.

This embodiment of the present invention may conveniently be used to demonstrate that a person does not suffer from adult-type hypolactasia and has no predisposition therefor. Further, this nucleic acid molecule reflecting the "wild-type" situation of the position -13910 or -22018 upstream of the LPH gene may be used as a control means in experiments where a predisposition to adult-type hypolactasia is tested for.

For testing, methods as described throughout this specification may be used.

In a preferred embodiment of the invention the nucleic acid molecule is genomic DNA.

- 5 This preferred embodiment of the invention reflects the fact that usually the analysis would be carried out on the basis of genomic DNA from body fluid, cells or tissue isolated from the person under investigation.

10 In a further preferred embodiment of the nucleic acid molecule of the invention said genomic DNA is part of a gene.

In accordance with the invention, it is preferred that at least one of the introns of the MCM6 gene harboring position -13910 or position -22018 relative to the LPH gene is analyzed.

- 15 In addition, the invention relates to a fragment of the nucleic acid molecule as described herein above having at least 14 nucleotides wherein said fragment comprises nucleotide position -13910 or nucleotide position -22018 (upstream) of the LPH gene.

The fragment of the invention may be of natural as well as of (semi)synthetic origin.
20 Thus, the fragment may, for example, be a nucleic acid molecule that has been synthesized according to conventional protocols of organic chemistry. Importantly, the nucleic acid fragment of the invention comprises nucleotide position -13910 or nucleotide position -22018 upstream of the LPH gene. In these positions, the fragment may have either the wild-type nucleotide or the nucleotide contributing to or
25 indicative of adult-type hypolactasia (also referred to as the "mutant" sequence). Consequently, the fragment of the invention may be used, for example, in assays differentiating between the wild-type and the mutant sequence.

It is further preferred that the fragment of the invention consists of at least 17 nucleotides, more preferred at least 21 nucleotides, and most preferred at least 25
30 nucleotides such as 30 nucleotides.

Furthermore, the invention relates to a nucleic acid molecule which is complementary to the nucleic acid molecule as described herein above.

This embodiment of the invention comprising at least 14 nucleotides and covering at least position -13910 or position -22018 of the sequence upstream of the LPH gene is particularly useful in the analysis of the genetic setup in the recited positions in hybridization assays. Thus, for example, a 15mer exactly complementary either to
5 the wild-type sequence (i.e. a T in position -13910 or an A in position -22018) or to the variants contributing to or indicative of adult-type hypolactasia (i.e. a C in position -13910 or a G in position -22018) may be used to differentiate between the polymorphic variants. This is because a nucleic acid molecule labeled with a detectable label not exactly complementary to the DNA in the analyzed sample will
10 not give rise to a detectable signal, if appropriate hybridization and washing conditions are chosen.

In this regard, it is important to note that the nucleic acid molecule of the invention, the fragment thereof as well as the complementary nucleic acid molecule may be
15 detectably labeled. Detectable labels include radioactive labels such as ^3H , or ^{32}P or fluorescent labels. Labeling of nucleic acids is well understood in the art and described, for example, in Sambrook et al., loc. cit..

In addition, the invention relates to a vector comprising the nucleic acid molecule as
20 described herein above. The vector of the invention may either contain a nucleic acid molecule comprising the wild-type sequence(s) or it may contain a nucleic acid molecule comprising the mutant sequence(s).

The vectors may particularly be plasmids, cosmids, viruses or bacteriophages used conventionally in genetic engineering that comprise the nucleic acid molecule of the
25 invention. Preferably, said vector is an expression vector and/or a gene transfer or targeting vector. Expression vectors derived from viruses such as retroviruses, vaccinia virus, adeno-associated virus, herpes viruses, or bovine papilloma virus, may be used for delivery of the nucleic acid molecule of the invention into targeted cell population. Methods which are well known to those skilled in the art can be used
30 to construct recombinant viral vectors; see, for example, the techniques described in Sambrook et al., loc. cit. and Ausubel et al., Current Protocols in Molecular Biology, Green Publishing Associates and Wiley Interscience, N.Y. (1989). Alternatively, the nucleic acid molecules and vectors of the invention can be reconstituted into

liposomes for delivery to target cells. The vectors containing the nucleic acid molecules of the invention can be transferred into the host cell by well-known methods, which vary depending on the type of cellular host. For example, calcium chloride transfection is commonly utilized for prokaryotic cells, whereas, e.g., calcium phosphate or DEAE-Dextran mediated transfection or electroporation may be used
5 for other cellular hosts; see Sambrook, supra.

Such vectors may comprise further genes such as marker genes which allow for the selection of said vector in a suitable host cell and under suitable conditions. Preferably, the nucleic acid molecule of the invention is operatively linked to
10 expression control sequences allowing expression in prokaryotic or eukaryotic cells. Expression of said polynucleotide comprises transcription of the polynucleotide into a translatable mRNA. Regulatory elements ensuring expression in eukaryotic cells, preferably mammalian cells, are well known to those skilled in the art. They usually comprise regulatory sequences ensuring initiation of transcription and, optionally, a
15 poly-A signal ensuring termination of transcription and stabilization of the transcript, and/or an intron further enhancing expression of said polynucleotide. Additional regulatory elements may include transcriptional as well as translational enhancers, and/or naturally-associated or heterologous promoter regions. Possible regulatory elements permitting expression in prokaryotic host cells comprise, e.g., the PL, lac, trp or tac promoter in *E. coli*, and examples for regulatory elements permitting
20 expression in eukaryotic host cells are the AOX1 or GAL1 promoter in yeast or the CMV-, SV40-, RSV-promoter (Rous sarcoma virus), CMV-enhancer, SV40-enhancer or a globin intron in mammalian and other animal cells. Beside elements which are responsible for the initiation of transcription such regulatory elements may also
25 comprise transcription termination signals, such as the SV40-poly-A site or the tk-poly-A site, downstream of the polynucleotide. Optionally, the heterologous sequence can encode a fusion protein including an C- or N-terminal identification peptide imparting desired characteristics, e.g., stabilization or simplified purification of expressed recombinant product. In this context, suitable expression vectors are
30 known in the art such as Okayama-Berg cDNA expression vector pcDV1 (Pharmacia), pCDM8, pRc/CMV, pcDNA1, pcDNA3, the Echo™ Cloning System (Invitrogen), pSPORT1 (GIBCO BRL) or pRevTet-On/pRevTet-Off or pCI (Promega). Preferably, the expression control sequences will be eukaryotic promoter systems in

vectors capable of transforming or transfecting eukaryotic host cells, but control sequences for prokaryotic hosts may also be used.

As mentioned above, the vector of the present invention may also be a gene transfer or targeting vector. Gene therapy, which is based on introducing therapeutic genes
5 into cells by ex-vivo or in-vivo techniques is one of the most important applications of gene transfer. Suitable vectors and methods for in-vitro or in-vivo gene therapy are described in the literature and are known to the person skilled in the art; see, e.g., Giordano, *Nature Medicine* 2 (1996), 534-539; Schaper, *Circ. Res.* 79 (1996), 911-919; Anderson, *Science* 256 (1992), 808-813; Isner, *Lancet* 348 (1996), 370-374;
10 Muhlhauser, *Circ. Res.* 77 (1995), 1077-1086; Wang, *Nature Medicine* 2 (1996), 714-716; WO94/29469; WO 97/00957, Schaper, *Current Opinion in Biotechnology* 7 (1996), 635-640, or Kay et al. (2001) *Nature Medicine*, 7, 33-40) and references cited therein. The polynucleotides and vectors of the invention may be designed for direct introduction or for introduction via liposomes, or viral vectors (e.g. adenoviral,
15 retroviral) into the cell. Preferably, said cell is a germ line cell, embryonic cell, or egg cell or derived therefrom, most preferably said cell is a stem cell. Gene therapy is envisaged with the wild-type nucleic acid molecule only.

The invention as well relates to a primer or primer pair, wherein the primer or primer
20 pair hybridizes under (highly) stringent conditions to the nucleic acid as described herein above comprising nucleotide position -13910 or -22018 of the LPH gene or to the complementary strand thereof.

Preferably, the primers of the invention have a length of at least 14 nucleotides such as 17 or 21 nucleotides. It is further preferred that the primers have a maximum
25 length of 24 nucleotides. Hybridization or lack of hybridization of a primer under appropriate conditions to a genome sequence comprising either position -13910 or position -22018 coupled with an appropriate detection method such as an elongation reaction or an amplification reaction may be used to differentiate between the polymorphic variants and then draw conclusions with regard to, e.g., the
30 predisposition of the person under investigation for adult-type hypolactasia. The present invention envisages two types of primers/primer pairs. One type hybridizes to a sequence comprising the mutant sequence. In other words, the primer is exactly complementary to a sequence that contains the C in position -13910 or the G in

position -22018 or to the complementary strand thereof. The other type of primer is exactly complementary to a sequence having a T in position -13910 or an A in position -22018 or to the complementary strand thereof. Since hybridization conditions would preferably be chosen to be stringent enough, contacting of e.g. a primer exactly complementary to the mutant sequence with a wild-type allele would not result in efficient hybridization due to the mismatch formation. After washing, no signal would be detected due to the removal of the primer.

Additionally, the invention relates to a non-human host transformed with the vector of the invention as described herein above. The host may either carry the mutant or the wild-type sequence. Upon breeding etc. the host may be heterozygous or homozygous for one or both SNPs.

The host of the invention may carry the vector of the invention either transiently or stably integrated into the genome. Methods for generating the non-human host of the invention are well known in the art. For example, conventional transfection protocols described in Sambrook et al., loc. cit., may be employed to generate transformed bacteria (such as *E. coli*) or transformed yeasts. The non-human host of the invention may be used, for example, to elucidate the onset of adult-type hypolactasia.

In a preferred embodiment of the invention the non-human host is a bacterium, a yeast cell, an insect cell, a fungal cell, a mammalian cell, a plant cell, a transgenic animal or a transgenic plant.

Whereas *E. coli* is a preferred bacterium, preferred yeast cells are *S. cerevisiae* or *Pichia pastoris* cells. Preferred fungal cells are *Aspergillus* cells and preferred insect cells include *Spodoptera frugiperda* cells. Preferred mammalian cells are colon carcinoma cell lines showing expression of the LPH enzyme and include CaCo2-cells.

A method for the production of a transgenic non-human animal, for example transgenic mouse, comprises introduction of the aforementioned polynucleotide or targeting vector into a germ cell, an embryonic cell, stem cell or an egg or a cell derived therefrom. The non-human animal can be used in accordance with a screening method of the invention described herein. Production of transgenic

embryos and screening of those can be performed, e.g., as described by A. L. Joyner Ed., *Gene Targeting, A Practical Approach* (1993), Oxford University Press. The DNA of the embryonal membranes of embryos can be analyzed using, e.g., Southern blots with an appropriate complementary nucleic acid molecule; see supra. A general method for making transgenic non-human animals is described in the art, see for example WO 94/24274. For making transgenic non-human organisms (which include homologously targeted non-human animals), embryonal stem cells (ES cells) are preferred. Murine ES cells, such as AB-1 line grown on mitotically inactive SNL76/7 cell feeder layers (McMahon and Bradley, *Cell* 62:1073-1085 (1990)) essentially as described (Robertson, E. J. (1987) in *Teratocarcinomas and Embryonic Stem Cells: A Practical Approach*. E. J. Robertson, ed. (Oxford: IRL Press), p. 71-112) may be used for homologous gene targeting. Other suitable ES lines include, but are not limited to, the E14 line (Hooper et al., *Nature* 326:292-295 (1987)), the D3 line (Doetschman et al., *J. Embryol. Exp. Morph.* 87:27-45 (1985)), the CCE line (Robertson et al., *Nature* 323:445-448 (1986)), the AK-7 line (Zhuang et al., *Cell* 77:875-884 (1994)). The success of generating a mouse line from ES cells bearing a specific targeted mutation depends on the pluripotency of the ES cells (i. e., their ability, once injected into a host developing embryo, such as a blastocyst or morula, to participate in embryogenesis and contribute to the germ cells of the resulting animal). The blastocysts containing the injected ES cells are allowed to develop in the uteri of pseudopregnant nonhuman females and are born as chimeric mice. The resultant transgenic mice are chimeric for cells having the desired nucleic acid molecule are backcrossed and screened for the presence of the correctly targeted transgene (s) by PCR or Southern blot analysis on tail biopsy DNA of offspring so as to identify transgenic mice heterozygous for the nucleic acid molecule of the invention.

The transgenic non-human animals may, for example, be transgenic mice, rats, hamsters, dogs, monkeys (apes), rabbits, pigs, or cows. Preferably, said transgenic non-human animal is a mouse. The transgenic animals of the invention are, inter alia, useful to study the phenotypic expression/outcome of the nucleic acids and vectors of the present invention. Furthermore, the transgenic animals of the present invention are useful to study the developmental expression of the LPH enzyme, for example in

the rodent intestine. It is furthermore envisaged, that the non-human transgenic animals of the invention can be employed to test for therapeutic agents/compositions or other possible therapies which are useful to ameliorate adult-type hypolactasia.

- 5 In addition, the invention relates to an antibody or aptamer or phage that specifically binds to the mutant nucleic acid molecule of the invention but not to the corresponding wild type nucleic acid molecule.

The antibody may be tested for binding and used in any serologic technique well known in the art, such as agglutination techniques in tubes, gels, solid phase and
10 capture techniques with or without secondary antibodies, or in flow cytometry with or without immunofluorescence enhancement (see, for example, techniques described in Harlow and Lane „Antibodies, A Laboratory Manual“, CSH Press, Cold Spring Harbor, USA, 1988 (see reference 53).

- 15 In line with the invention, the antibody specifically recognizes an epitope comprising position -13910 (wherein the nucleotide is C) or position -22018 (wherein the nucleotide is G). It does not or essentially does not cross-react with an epitope comprising position -13910 with a T in this position nor with the epitope comprising position -22018 with a G in this position. Specificity of an antibody which may be
20 generated according to standard protocols, may be tested by contacting with DNA molecules carrying the wild-type and the mutant sequence such as in an ELISA assay. Only those antibodies will be selected that produce a signal over background with the mutant sequence but not with the wild-type sequence.

- 25 The antibody of the invention may be a monoclonal antibody or an antibody derived from or comprised in a polyclonal antiserum. The term "antibody", as used in accordance with the present invention, further comprises fragments of said antibody such as Fab, F(ab')₂, Fv or scFv fragments; see, for example, Harlow and Lane⁵³, loc. cit. The antibody or the fragment thereof may be of natural origin or may be
30 (semi)synthetically produced. Such synthetic products also comprise non-proteinaceous as semi-proteinaceous material that has the same or essentially the same binding specificity as the antibody of the invention. Such products may, for example, be obtained by peptidomimetics.

The term "aptamer" is well known in the art and defined, e.g., in Osborne et al., *Curr. Opin. Chem. Biol.* 1 (1997), 5-9 (see reference 51) or in Stall and Szoka, *Pharm. Res.* 12 (1995), 465-483 (see reference 52).

5 Moreover, the invention relates to an antibody or aptamer or phage that specifically binds to the wild-type nucleic acid molecule as described herein above but not to the corresponding mutant sequence contributing to or indicative of adult-type hypolactasia. The statements with respect to specificity etc. made for the antibody which is specific for the mutant sequence apply *mutatis mutandis* here.

10

Furthermore, the invention relates to a pharmaceutical composition comprising the wild-type nucleic acid molecule as described herein above.

15

The pharmaceutical composition of the invention may be used in gene therapy approaches, particularly in somatic gene therapy.

The wild-type nucleic acid molecule referred to above and contained in the pharmaceutical composition of the invention may be combined with a pharmaceutically acceptable carrier and/or diluent.

20

Examples of suitable pharmaceutical carriers are well known in the art and include phosphate buffered saline solutions, water, emulsions, such as oil/water emulsions, various types of wetting agents, sterile solutions etc. Compositions comprising such carriers can be formulated by well known conventional methods. These pharmaceutical compositions can be administered to the subject at a suitable dose.

25

Administration of the suitable compositions may be effected by different ways, e.g., by intravenous, intraperitoneal, subcutaneous, intramuscular, topical, intradermal, intranasal or intrabronchial administration. The dosage regimen will be determined by the attending physician and clinical factors. As is well known in the medical arts, dosages for any one patient depends upon many factors, including the patient's size, body surface area, age, the particular compound to be administered, sex, time and route of administration, general health, and other drugs being administered concurrently. A typical dose can be, for example, in the range of 0.001 to 1000 μg of nucleic acid for expression or for inhibition of expression; however, doses below or above this exemplary range are envisioned, especially considering the

30

aforementioned factors. Dosages will vary but a preferred dosage for intravenous administration of DNA is from approximately 10^6 to 10^{12} copies of the DNA molecule. Progress can be monitored by periodic assessment. The compositions of the invention may be administered locally or systemically. Administration will generally be parenterally, e.g., intravenously; DNA may also be administered directly to the target site, e.g., by biolistic delivery to an internal or external target site or by catheter to a site in an artery. Preparations for parenteral administration include sterile aqueous or non-aqueous solutions, suspensions, and emulsions. Examples of non-aqueous solvents are propylene glycol, polyethylene glycol, vegetable oils such as olive oil, and injectable organic esters such as ethyl oleate. Aqueous carriers include water, alcoholic/aqueous solutions, emulsions or suspensions, including saline and buffered media. Parenteral vehicles include sodium chloride solution, Ringer's dextrose, dextrose and sodium chloride, lactated Ringer's, or fixed oils. Intravenous vehicles include fluid and nutrient replenishers, electrolyte replenishers (such as those based on Ringer's dextrose), and the like. Preservatives and other additives may also be present such as, for example, antimicrobials, anti-oxidants, chelating agents, and inert gases and the like.

Additionally, the invention relates to a diagnostic composition comprising the nucleic acid molecule as described herein above, the vector as described herein above, the primer or primer pair as described herein above, and/or the antibody aptamer and/or phage as described herein above.

The diagnostic composition is useful for assessing the genetic status of a person with respect to his or her predisposition to develop adult-type hypolactasia or with regard to the diagnosis of the acute condition. The various possible components of the diagnostic composition may be packaged in one or more vials, in a solvent or otherwise such as in lyophilized form. If dissolved in a solvent, the diagnostic composition is preferably cooled to at least $+8^{\circ}\text{C}$ to $+4^{\circ}\text{C}$. Freezing may be preferred in other instances.

The invention also relates to a method for testing for the presence or predisposition of adult-type hypolactasia or associated trait comprising testing a sample obtained from a prospective patient or from a person suspected of carrying such a

predisposition to the presence of the nucleic acid molecule as described herein above in a homozygous or heterozygous state. In varying embodiments, it may be tested either for the presence of the wild-type sequence(s) or of the mutant sequence(s).

5

The method of the invention is useful for detecting the genetic set-up of said person/patient and drawing appropriate conclusions whether a condition from which said patient suffers is adult-type hypolactasia. Alternatively, it may be assessed whether a person not suffering from a condition carries a predisposition to adult-type hypolactasia. With regard to position -13910 upstream of the LPH gene, only if cytosine is found in a homozygous state, a condition would be diagnosed as adult-type hypolactasia or a corresponding predisposition would be manifest. On the other hand, if thymidine is found in a homozygous state or if the individual is heterozygous (C/T), then it may be concluded that a condition from which a patient suffers is not related to adult-type hypolactasia and further, that the patient does not carry a predisposition to develop this condition. It may, however, be concluded that children of persons carrying the heterozygous genotype may develop the condition if chromosome carrying the C residue is matched with a corresponding chromosome from the other parent.

20

The situation is similar and essentially the same conclusions apply for the analysis of the SNP in position -22018. A homozygously occurring G residue marks a predisposition to or the occurrence of acute adult-type hypolactasia. A heterozygous G/A state correlates with a high likelihood to not develop the condition. Individuals carrying A in a homozygous state would not be expected to develop the condition. Similarly, patients suffering from a condition would be diagnosed not to suffer from adult-type hypolactasia.

25

In a preferred embodiment of the method of the invention said testing comprises hybridizing the complementary nucleic acid molecule as described herein above which is complementary to the nucleic acid molecule contributing to or indicative of adult-type hypolactasia or the nucleic acid molecule as described herein above which is complementary to the wild-type sequence as a probe under (highly) stringent

30

conditions to nucleic acid molecules comprised in said sample and detecting said hybridization.

Again, depending on the nucleic acid probe used, either wild-type or mutant sequences (i.e. sequences contributing to or indicative of adult-type hypolactasia) would be detected. It is understood that hybridization conditions would be chosen such that a nucleic acid molecule complementary to wild-type sequences would not or essentially not hybridize to the mutant sequence. Similarly, a nucleic acid molecule complimentary to the mutant sequence would not or would not essentially not hybridize to the wild-type sequence. In order to differentiate between results obtained from homozygous and heterozygous genotypes in the hybridization methods of the invention, one can for example monitor/detect the strength/intensity of the respective detection signal after the hybridization. To differentiate between wild-type homozygous, heterozygous and/or mutant homozygous alleles in the hybridization methods of the invention, internal control samples of the corresponding genotypes will be included in the analysis.

In a further preferred embodiment, the method of the invention further comprises digesting the product of said hybridization with a restriction endonuclease or subjecting the product of said hybridization to digestion with a restriction endonuclease and analyzing the product of said digestion.

This preferred embodiment of the invention allows by convenient means, the differentiation between an effective hybridization and a non-effective hybridization. For example, if the DNA sequence adjacent to position -13910 or position -22018 comprises an endonuclease restriction site, the hybridized product will be cleavable by an appropriate restriction enzyme upon an effective hybridization whereas a lack of hybridization will yield no double-stranded product or will not comprise the recognizable restriction site and, accordingly, will not be cleaved. In particular, the restriction enzymes specific for the sequence of the DNA-variant C/T₋₁₃₉₁₀ is CviJ I, for the DNA-variant G/A₋₂₂₀₁₈ are HhaI and Acl I. Said restriction enzymes which cut rg/cy where found by the use of the program Webcutter. The analysis of the digestion product can be effected by conventional means, such as by gel electrophoresis which may be optionally combined by the staining of the nucleic acid with, for example, ethidium bromide. Combinations with further techniques such as Southern

blotting are also envisaged.

Detection of said hybridization may be effected, for example, by an anti-DNA double-strand antibody or by employing a labeled oligonucleotide. Conveniently, the method
5 of the invention is employed together with blotting techniques such as Southern or Northern blotting and related techniques. Labeling may be effected, for example, by standard protocols and includes labeling with radioactive markers, fluorescent, phosphorescent, chemiluminescent, enzymatic labels, etc. (see also above).

10 In accordance with the above, in another preferred embodiment of the method of the invention said probe is detectably labeled, e.g. by the methods and with the labels described herein above.

In yet another preferred embodiment of the method of the invention said testing
15 comprises determining the nucleic acid sequence of at least a portion of the nucleic acid molecule as described herein above, said portion comprising nucleotide position -13910 and/or nucleotide position -22018 of the LPH gene.

Determination of the nucleic acid molecule may be effected in accordance with one of the conventional protocols such as the Sanger or Maxam/Gilbert protocols (see
20 Sambrook et al., loc. cit., for further guidance).

In a further preferred embodiment of the method of the invention the determination of the nucleic acid sequence is effected by solid-phase minisequencing. Solid-phase minisequencing is based on quantitative analysis of the wild type and mutant
25 nucleotide in a solution. First, the genomic region containing the mutation is amplified by PCR with one biotinylated and non-biotinylated primer where the biotinylated primer is attached to a streptavidin (SA) coated plate. The PCR-product is denatured to a single stranded form to allow a minisequencing primer to bind to this strand just before the site of the mutation. The tritium (H3) or fluorescence labeled mutated and
30 wild type nucleotides together with nonlabeled dNTPs are added to the minisequencing reaction and sequenced using Taq-polymerase. The result is based on the amount of wild type and mutant nucleotides in the reaction measured by beta counter or fluorometer and expressed as an R-ratio. See also Syvänen AC, Sajantila

A, Lukka M. Am J Hum Genet 1993: 52,46-59 and Suomalainen A and Syvanen AC. Methods Mol Biol 1996;65:73-79.

A preferred embodiment of the method of the invention further comprises, prior to determining said nucleic acid sequence, amplification of at least said portion of said nucleic acid molecule.

Preferably, amplification is effected by polymerase chain reaction (PCR). Other amplification methods such as ligase chain reaction may also be employed.

In a preferred embodiment of the method of the invention said testing comprises carrying out an amplification reaction wherein at least one of the primers employed in said amplification reaction is the primer as described herein above or belongs to the primer pair as described herein above, comprising assaying for an amplification product. In this embodiment and depending on the information the investigator/physician wishes to obtain, primers hybridizing either to the wild-type or mutant sequences may be employed.

The method of the invention will result in an amplification of only the target sequence, if said target sequence carries a sequence exactly complementary to the primer used for hybridization. This is because the oligonucleotide primer will under preferably (highly) stringent hybridization conditions not hybridize to the wild-type/mutant sequence – depending which type of primer is used – (with the consequence that no amplification product is obtained) but only to the exactly matching sequence. Naturally, combinations of primer pairs hybridizing to both SNPs may be used. In this case, the analysis of the amplification products expected (which may be no, one, two, three or four amplification product(s) if the second, non-differentiating primer is the same for each locus) will provide information on the genetic status of both positions – 13910 and –22018.

In a preferred embodiment of the method of the invention said amplification is effected by or said amplification is the polymerase chain reaction (PCR).

The PCR is well established in the art. Typical conditions to be used in accordance with the present invention include for example a total of 35 cycles in a total of 50 μ l volume exemplified with a denaturation step at 93° C for 3 minutes; an annealing

step at 55° C for 30 seconds; an extension step at 72° C for 75 seconds and a final extension step at 72° C for 10 minutes.

5 The invention furthermore relates to a method for testing for the presence or predisposition of adult-type hypolactasia comprising assaying a sample obtained from a human for specific binding to the antibody or aptamer or phage as described herein above. In this context a weaker staining for the presence of the antigen of the invention compared to homozygous wild type control samples (comprising two persistent alleles) is indicative for the heterozygous wild type (one persistent allele and
10 one hypolactasic allele, whereas for the homozygous hypolactasic individual no staining is expected if the appropriate antibody is used. Preferably, the method of the invention is performed in the presence of control samples corresponding to all three possible allelic combinations as internal controls. Testing may be carried out with an antibody etc. specific for the wild-type or specific for the mutant sequence.
15 Testing for binding may, again, involve the employment of standard techniques such as ELISAs; see, for example, Harlow and Lane⁵³, loc. cit.

In a preferred embodiment of the method of the invention said antibody or aptamer or phage is detectably labeled.

20 Whereas the aptamers are preferably radioactively labeled with ³H or ³²P or with a fluorescent marker as described above, the phage or antibody may either be labeled in a corresponding manner (with ¹³¹I as the preferred radioactive label) or be labeled with a tag such as His-tag, FLAG-tag or myc-tag.

25 In a further preferred embodiment of the method of the invention the test is an immuno-assay.

In another preferred embodiment of the method of the invention said sample is blood, serum, plasma, fetal tissue, saliva, urine, mucosal tissue, mucus, vaginal tissue, fetal
30 tissue obtained from the vagina, skin, hair, hair follicle or another human tissue.

In an additional preferred embodiment of the method of the invention said nucleic acid molecule from said sample is fixed to a solid support.

Fixation of the nucleic acid molecule to a solid support will allow an easy handling of the test assay and furthermore, at least some solid supports such as chips, silica wafers or microtiter plates allow for the simultaneous analysis of larger numbers of samples. Ideally, the solid support allows for an automated testing employing, for example, roboting devices.

In a particularly preferred embodiment of the method of the invention said solid support is a chip, a silica wafer, a bead or a microtiter plate.

Furthermore, the invention relates to the use of the nucleic acid molecule as described herein above for the analysis of the presence or predisposition of adult-type hypolactasia.

The nucleic acid molecule simultaneously allows for the analysis of the absence of the condition or the predisposition to the condition, as has been described in detail herein above.

In addition, the invention relates to a kit comprising the nucleic acid molecule as described herein above, the primer or primer pair as described herein above, the vector as described herein above, and/or the antibody aptamer and/or phage as described herein above in one or more containers.

The invention as well relates to the use of the nucleic acid molecule as described herein above or the vector as described herein above in gene therapy.

Gene therapy approaches have been discussed herein above in connection with the vector of the invention and equally apply here. It is of note that in accordance with this invention, also fragments of the nucleic acid molecules as defined herein above and as, in particular, depicted in SEQ ID NOs: 3 to 4 may be employed in gene therapy approaches. Said fragments comprise the nucleotide at position -13910 as defined in (c) herein above (and also shown in SEQ ID NO: 3) or position -22018 as defined in (d) herein above (and as shown in SEQ ID NO: 4). Preferably, said fragments comprise at least 200, at least 250, at least 300, at least 400 and most preferably at least 500 nucleotides.

In a preferred embodiment of the use of the invention said gene therapy treats or prevents adult-type hypolactasia.

5 The figures show:

Fig. 1: The Finnish adult-type hypolactasia families studied. Blackened symbols indicate hypolactasic individuals, asterisk (*) indicate that no sample was available, question mark (?) indicates unknown affection status. ↑ indicates the individuals used for sequencing for SNP identification (Table 2).
10

Fig 2: Physical map of adult-type hypolactasia locus. BAC clones are shown above the horizontal line. The three genes LPH, MCM6 and DARS are shown by thick black arrows with the tip pointed toward the 3' end of the gene above the black boxes. The position of ten polymorphic microsatellite markers used for fine mapping of the locus are shown. The backslash in the horizontal line denotes a gap in the sequence of the contig sequence. The position of marker D2S2169 was confirmed by bridging the gap with PAC 106O20 isolated from the PAC library as described before⁴⁰. The organisation of the MCM6 gene is shown including the position of the lactase persistent phenotype-associated variants in introns 9 and 13 located 13.9 kb and 22 kb 5' of the first ATG of LPH.
15
20

Fig. 3: Extended haplotype analysis of the persistent chromosomes derived from Finnish adult-type hypolactasia families using seven closely linked microsatellite markers. The haplotypes representing the ancestral founder persistent chromosome are shaded. Only the haplotypes of non-persistent chromosomes that were also present in the persistent chromosomes are shown. On the basis of ancestral recombinations, the adult-type hypolactasia locus could be restricted to 47 kb interval between markers LPH1 and AC3.
5
10
15

Fig. 4: The sequence comprised in the sequence of intron 13 of the MCM6 gene (3220bp) comprising the SNP at position -13910 in which the T, which is

specific for the lactase persistence, is substituted by a C. Said position is indicated by the use of a small letter. This sequence refers to SEQ ID NO:1.

- 5 **Fig. 5:** The sequence comprised in the sequence of intron 9 of the MCM6 gene(1295bp) comprising the SNP at position –22018 in which the A, which is specific for the lactase persisting-type sequence is substituted by a G. Said position is indicated by the use of a small letter. This sequence refers to SEQ ID NO:2.
- 10 **Fig. 6:** The sequence of the lactase persisting-type intron 13 of the MCM6 gene (3220bp) comprising at position –13910 a T. Said position is indicated by the use of a small letter. This sequence refers to SEQ ID NO:3.
- 15 **Fig. 7:** The sequence of the lactase persisting-type intron 9 of the MCM6 gene(1295bp) comprising at position –22018 an A. Said position is indicated by the use of a small letter. This sequence refers to SEQ ID NO:4.
- 20 **Fig. 8:** The sequence of intron 13 of the MCM6 gene (3220bp) comprising the SNP at position –13910 in which the T, which is specific for the lactase persisting-type sequence is substituted by a C. Said position is indicated by the use of a small letter. This sequence refers to SEQ ID NO:5.
- 25 **Fig. 9:** The sequence of intron 9 of the MCM6 gene(1295bp) comprising the SNP at position –22018 in which the A, which is specific for the lactase persisting-type sequence is substituted by a G. Said position is indicated by the use of a small letter. This sequence refers to SEQ ID NO:6.

The examples illustrate the invention.

Example 1: Linkage and linkage disequilibrium analysis

5 Seven polymorphic microsatellite markers between D2S114 and D2S2385 flanking the *LPH* gene on 2q21 were analyzed in nine extended Finnish hypolactasia families (Fig. 1). Significant evidence for linkage was found with markers D2S314, D2S442, D2S2196 and D2S1334, with a maximum lod score of 7.67 at $\theta = 0$ obtained with marker D2S2196 (Table 1). Obligatory recombination events were detected with
10 marker D2S114 (family B, IV3), which defines the centromeric boundary for the lactase persistence/non-persistence locus, and with marker D2S2385 (family B, IV17) (Fig. 1, Table 1), which defines the telomeric boundary of the locus. To fine map the critical region, nine additional polymorphic markers were analyzed (Table 1). Linkage disequilibrium (LD) over the region was monitored conditional on the detected linkage
15 treating the allele frequencies and the recombination fraction as nuisance parameters¹⁶⁻¹⁷. Six out of nine markers (LPH13, LPH2, LPH1, AC3, AC4, and AC10), spanning over ~200kb interval showed highly significant evidence of LD ($p < 10^{-4}$) whereas markers 3' from the *LPH* gene showed no evidence of LD (Table 1). Two markers, LPH2 and AC3, displayed the most significant linkage disequilibrium in
20 the lactase persistence alleles ($p < 10^{-7}$).

The family material consisted of nine extended Finnish pedigrees originally studied by Sahi⁵. All family material was tested for adult-type hypolactasia in the 1970s. The family material for this study was enlarged by collecting the DNA of the family
25 members in the younger generations. The family material in this study consisted of 194 individuals in total (Fig. 1). The phenotypic status of all family members was confirmed by lactose tolerance tests with ethanol (LTTE)⁴⁻⁵ in all but 49 individuals. Gluten enteropathy has been excluded in all affected patients by measurement of the serum IgA anti-tissue transglutaminase⁴⁵. DNA was extracted from blood samples
30 taken from all participating family members in accordance with standard protocols⁴⁶, after obtaining informed consent. As a case-control study 196 random DNA samples isolated from jejunal biopsy specimens from which disaccharidase activities had been measured⁴⁷ at the Helsinki University Hospital were sequenced. DNA was isolated

from intestinal biopsies according to the standard protocol⁴⁶. These series comprised 137 lactase persistent and 59 non-persistent samples. In addition DNA from nine Italian, kindly provided by M. Rossi, University of Naples, nine German DNA samples, kindly provided by M. Lentze, University of Bonn and twenty two South Korean, kindly provided by J.K. Seo, Seoul National University, intestinal biopsy sample specimens were analyzed (In the table: 23 Korean, 9 Italian and 7 Germans (One of the cases from Germany originated from South Korea). The diagnosis was based on the measurement of disaccharidase activities. Finally, to determine the frequency of the C/T₋₁₃₉₁₀ variant in the Finnish population, the DNA of 938 anonymous Finnish blood donors from small parishes from Eastern and Western Finland and the DNA of 109 parents belonging to the CEPH families¹⁹ were analyzed. In addition, genomic DNA from a baboon (*Papio hemedryas ussinus*) isolated from liver biopsy using standard protocols⁴⁸ was analyzed. The study was approved by the Ethical Committees of the Helsinki University Hospital and the Finnish Red Cross Blood Transfusion Service.

Example 2: Extended haplotype analysis

In the first stage ten highly polymorphic microsatellite markers flanking the *LPH* gene on 2q21 were analyzed as described elsewhere^{40,55}. Briefly, the ten highly polymorphic microsatellite markers on 2q in the vicinity of the lactase gene from The Généthon Resource Center⁵⁵ were analyzed with genetic distances as follows: cen - D2S114 - 1cM - D2S1334 - 0cM - D2S2196 - 0cM - D2S442 - 2cM - D2S314 - 2cM - D2S2385 - 1cM - D2S2288 - 1cM - D2S397 - 1cM - D2S150- 1cM - D2S132. The order of the markers has been mostly obtained from the physical YAC contig map of chromosome 2 (Chumakov et al. 1995⁵⁶) supplemented with the Généthon map. PCR was performed in a total volume of 15 ul containing 12ng of template DNA, 5pmol of primers, 0.2mM of each nucleotide, 20mMTrisHCl (pH 8.8), 15 mM (NH₄)₂S₀₄, 1.5 mM MgCl₂, 0.1% Tween 20, 0.01% gelatin and 0.25U Taq polymerase (Dynazyme, Finnzymes). One of the primers was radiolabeled at the 5' end with ³²P-γATP. The reactions were performed in a multiwell microtitre plate for 35 cycles with denaturation at 94 °C for 30s, annealing at various temperatures

depending on the primers for 30s and extension at 72 °C for 30s; denaturation was set at 3min and final extension at 5min. The amplified fragments were separated on 6% polyacrylamide gel, and autoradiography was performed.

In the second stage, nine additional microsatellite markers within the contig
5 constructed over the *LPH* gene were identified from the published genomic sequence of the BACs (NH034L23, NH0318L13, NH0218L22, and RP11-329I1) using the Repeat Masker program (<http://ftp.genome.washington.edu/cgi-bin/RepeatMasker>). Primers flanking the repeats were synthesized. PCR conditions were as described elsewhere⁴⁰. The amplified fragments were separated on 6% polyacrylamide gel, and
10 autoradiography was performed.

Pairwise lod scores were calculated by use of the MLINK option of the LINKAGE program package⁴⁹. Autosomal recessive inheritance for adult-type hypolactasia with complete penetrance, no sex difference in recombination fractions, and a disease
15 allele frequency of 0.4 was assumed. Only individuals above 20 years of age were included in the study as the condition is manifested by that age in the Finnish population⁵⁻⁶. The affection status for individuals not confirmed by LTTE was regarded as unknown. Allele frequencies and heterozygosities for the markers were
20 estimated from family material using the Downfreq program for purposes of the parametric linkage analysis⁴⁹. Additionally, pseudomarker linkage and linkage disequilibrium analyses were performed, assuming autosomal recessive mode of inheritance¹⁶. A test of LD was performed conditional on the detected linkage treating the allele frequencies and the recombination fraction as nuisance parameters^{16,49}. *P*-values from these analyses are shown in Table 1. Haplotypes were constructed
25 manually for the microsatellite markers in this order: LPH1-LPH2-LPH13-AC7-AC3-AC4-AC5 (Fig. 3). A total of 54 non-persistent chromosomes and 33 persistent chromosomes in our family material were available for haplotype analysis.

The order of the closely linked markers was confirmed by assembling four BAC-
30 clones NH0034L23, NH0218L22, NH0318L13 and 329I10 in the critical region into one uninterrupted sequence segment. This contig extended from marker AC8 to the exon 10 of the aspartyl-tRNA synthetase (DARS) gene and covered a total of 222,5 kb (Fig. 2). Based on this physical map of the linked region, extended haplotypes

with seven markers covering a 150 kb interval (cen-LPH13-LPH2-LPH1-AC7-AC3-AC4-AC5-tel) (Fig. 3) were constructed. One major haplotype was present in 20 persistence alleles (60%) versus 3 of the non-persistence alleles (5%), whereas a wide diversity of haplotypes was observed in non-persistence alleles. The remaining
5 40 % of the haplotypes in the persistence alleles differed from the ancestral haplotype in a manner consistent with a breakdown of the haplotype by historical recombination events. Based on the conserved haplotype analysis, the locus for lactase persistence could be restricted to a 47 kb interval between markers LPH1 and AC3 (Fig.3)

10

Example 3: Sequence analysis of the adult-type hypolactasia locus

The 47 kb region between the markers LPH1 and AC3 was amplified in overlapping
15 PCR fragments from genomic DNA of several members of the nine hypolactase families and sequenced. The region contains the minichromosome maintenance (*MCM6*) gene¹⁸, which covers 36 kb of the critical 47 kb region (Fig. 2). No variations were detected in the coding region of the *MCM6* gene but total of 52 variants; 43 SNPs and 9 deletion/ insertion polymorphisms, were identified in the critical 47 kb
20 region (Table 2). Only two of the variants (C/T₋₁₃₉₁₀, G/A₋₂₂₀₁₈) were associated with the lactase persistence/ non-persistence trait in the Finnish families (Tables 2 and 3). The first associated variant, C/T₋₁₃₉₁₀, resides in intron 13 of the *MCM6* gene at position -13910 bp from the first ATG-codon of the *LPH* gene. The second associated variant, G/A₂₂₀₁₈, is located in intron 9 of the *MCM6* gene at position -
25 22018 from the first ATG-codon of the *LPH* gene (Fig.2). These two variants, 8 kb apart from each other, completely cosegregated with adult-type hypolactasia in nine extended Finnish families. All hypolactasic (non-persistent) family members were homozygous for both C₋₁₃₉₁₀ and G₋₂₂₀₁₈ (Table 3). Interestingly, both these variants reside in repeat elements, C/T₋₁₃₉₁₀ in an L2-derived element and G/A₋₂₂₀₁₈ in an Alu
30 element.

Experimentally, three non-persistence, 2 homozygous persistence and 2 heterozygous persistence individuals sharing a similar haplotype across the critical

region from our family material were used for sequencing in the first stage (Fig. 1). Using the published draft genomic sequence of the BACs: NH0034L23, NH0218L22 NH0318L23, and RP-329I10 that covered the critical region of adult-type hypolactasia were assembled to one contig using Sequencher 4 software (Gene Codes Corporation). Oligonucleotide primers spanning the critical region between markers LPH1 and AC3 were designed (a list of oligonucleotide primers described herein below). PCR amplifications were carried out in a 50 μ l volume with genomic DNA (100 ng), primers (20 ng each), dNTPs (200 μ M), 0.5 U of *Taq* polymerase (Dynazyme, Finnzymes) in a standard buffer. Most PCR were amplified using the following PCR cycle conditions: an initial round of denaturation at 94 $^{\circ}$ C for 3 min, then 35 cycle at 94 $^{\circ}$ C at 30 s, 55 $^{\circ}$ C for 30 s, and 72 $^{\circ}$ C for 1.25 min and a final extension of 72 $^{\circ}$ C for 10 min, except that in cases where the size of the PCR products were more than 1kb we used the Dynazyme extend kit (conditions are described herein below). Purified PCR products (15-40 ng) were cycle sequenced using BigDye terminator chemistry (PE Biosystems). Data were analyzed using ABI Sequencing Analysis 3.3 (PE Biosystems) and Sequencher 4.1 (Gene Codes).

Detection of the Lactase variants by Sequencing:

PCR amplifications were carried out in a 50 μ l volume with genomic DNA (100 ng), primers (20 ng each), dNTPs (200 μ M), 0.5 U of *Taq* polymerase (Dynazyme, Finnzymes) in a standard buffer. Both PCRs were amplified using the following PCR cycle conditions: an initial round of denaturation at 94 $^{\circ}$ C for 3 min, then 35 cycles at 94 $^{\circ}$ C at 30 s, 55 $^{\circ}$ C for 30 s, and 72 $^{\circ}$ C for 1.25 min and a final extension of 72 $^{\circ}$ C for 10 min. PCR were purified by enzymatic reaction. Purified PCR products (15-40 ng) were cycle sequenced using BigDye terminator chemistry (PE Biosystems). Data were analyzed using ABI Sequencing Analysis 3.3 (PE Biosystems) and Sequencher 4.1 (Gene Codes).

Screening of the lactase variants by solid-phase minisequencing:

The DNA fragment spanning the C/T₋₁₃₉₁₀ variant was amplified using one biotinylated (5'-Bio-CCTCGTTAATACCCACTGACCTA-3') primer and unbiotinylated (5'-GTCACCTTTGATATGATGAGAGCA-3') primer. For G/A₋₂₂₀₁₈ biotinylated (5'-Bio-TGCTCAGGACATGCTGATCAA-3') and one unbiotinylated (5'-CTACCCTATCAGTAAAGGCCTA-3') primer were used under conditions described

above. 10 μ l of the PCR product was captured in a streptavidin coated microtiter well (Lab systems, Finland). The wells were washed, and bound DNA was denaturated as described by Syvänen et al. (Am J Hum Genet. (1993), 52, 46-59) and Syvänen and Landegren (Hum Mutat. (1994), 3, 172-9). 50 μ l of the minisequencing reaction mixture contained 10 pmoles of the minisequencing primers for C/T₋₁₃₉₁₅ (5'-GGCAATACAGATAAGATAATGTAG-3'), G/A₋₂₂₀₁₈ (5'-AAAAACAGCATTCTCAGCTGGGC-3'), and 0.1 μ l of either H-dCTP, H-dGTP corresponding to the lactase non-persistence allele (115 Ci/mmol; Ammersham, UK) or H-dTTP, H-sATP corresponding to the lactase persistence allele and 0.05 units of DNA polymerase (Dynazyme II, Finnzymes) in its buffer was added to each well. The microtiter plates were incubated for 20 min at 50°C, and the wells were washed. The detection was eluted, and the eluted radioactivity was measured in a liquid scintillation counter (Rackbeta 1209, Wallac, Finland). Two parallel minisequencing reactions were carried out for each PCR product.

15 PCR primers and detection primer for the C/T₋₁₃₉₁₀ variant:

Forward PCR primer:	GTCACCTTTGATATGATGAGAGCA	Tm 58	SEQ ID NO: 8
Detection primer:	GGCAATACAGATAAGATAATGTAG	Tm 58	SEQ ID NO: 10
Bio-Reverse primer:	Bio-CCTCGTTAATACCCACTGACCTA	Tm 62	SEQ ID NO: 9
or	Bio-TAGGTCAGTGGGTATTAACGAGGT		SEQ ID NO: 7

20 PCR primers and detection primer for the G/A₋₂₂₀₁₈ variant:

Forward PCR primer:	CTACCCTATCAGTAAAGGCCTA	Tm 58	SEQ ID NO: 12
Detection primer:	AAAAACAGCATTCTCAGCTGGGC	Tm 62	SEQ ID NO: 14
Bio-Reverse primer:	Bio-TGCTCAGGACATGCTGATCAA	Tm 62	SEQ ID NO: 13
or	Bio-TTGATCAGCATGTCCTGAGCA		SEQ ID NO: 11

25

Example 4: Monitoring the DNA-variants in a case/ control study sample

The frequency of the C/T₋₁₃₉₁₀ and G/A₋₂₂₀₁₈ variants was analyzed in DNA samples isolated from a total of 196 intestinal biopsy samples specimens which had been analyzed for disaccharidase activity as a diagnostic test for hypolactasia. A total of 59 samples showed primary lactase deficiency. Six out of 59 cases (Table 3) were heterozygous GA for the G/A₋₂₂₀₁₈ variant, the remaining 53 being homozygous for the G allele. All 59 samples were homozygous for the C allele of the variant C/T₋₁₃₉₁₀.

30

Among the 137 cases showing lactase persistence, 74 were found to be homozygous for alleles T and A, 63 being heterozygous CT and GA and none being homozygous for alleles C and G at C/T₋₁₃₉₁₀ and G/A₋₂₂₀₁₈, respectively (Table 3).

- 5 To analyze these variants in other populations, DNA samples isolated from intestinal biopsy specimens from 40 non-Finnish cases with established disaccharidase deficiency were sequenced: 23 cases originated from South Korea, 9 from Italy and 8 from Germany. One Italian case was heterozygous GA for G/A₋₂₂₀₁₈ whereas all remaining 39 cases were homozygous CC and GG for C/T₋₁₃₉₁₀ and G/A₋₂₂₀₁₈ respectively (Table 3). An extended study gave rise to the data provided in Table 7 representing data of the complete association of C/T₋₁₃₉₁₀ variant with the biochimically verified hypolactasia (lactase non-persistence) in 400 individuals for 6 different populations. The G/A₋₂₂₀₁₈ variant was associated with the lactase non-persistence in 400 out of 401 cases.

15

Example 5: Molecular epidemiology of the lactase persistence variant C/T₋₁₃₉₁₀

To monitor for the prevalence of the hypolactasia-associated variant in the Finnish population a solid-phase minisequencing method^{19,20} was used to screen DNA samples of 938 anonymous Finnish blood donors originating either from the Western early settlement region or the Eastern late settlement region of Finland (Table 4). Experimentally, the DNA fragment spanning the C/T₋₁₃₉₁₀ variant was amplified using one biotinylated (5'-CCTCGTTAATACCCCTGACCTA-3') primer and unbiotinylated (5'-GTCACCTTTGATATGATGAGAGCA-3') primer. For G/A₋₂₂₀₁₈ we used one biotinylated (5'-AGTCTGTGGCATGTGTCTTCATG-3') and one unbiotinylated (5'-TGCTCAGGACATGCTGATCAACT-3') primer under conditions described above. 10 µl of the PCR product was captured in a streptavidin coated microtitre well (Lab system, Finland). The wells were washed, and the bound DNA was denatured as described previously^{19,20}, 50 µl of the minisequencing reaction mixture contain 10 pmoles of the minisequencing primers for G/A₋₂₂₀₀₅ (5'-GACAAAGGTGTGAGCCACCG-3'), G/A₋₁₃₉₁₅ (5'-GGCAATACAGATAAGATAATGTAG-3') and 0,1 µl of either H-dCTP corresponding

to the lactase non-persistence allele (115 Ci/mmol; Amersham, UK) or H-dTTP corresponding to the lactase persistence allele and 0.05 units of DNA polymerase (Dynazyme II, Finnzymes) in its buffer was added to each well. The microtiter plates were incubated for 20 min at 50 °C, and the wells were washed. The detection primer
5 was eluted, and the eluted radioactivity was measured in a liquid scintillation counter (Rackbeta 1209, Wallac, Finland). Two parallel minisequencing reactions were carried out for each PCR product. The overall prevalence of the putative hypolactasia genotype CC-₁₃₉₁₀ (170 cases) was 18.1%, with higher prevalence (16.8% versus 18.9%) in the western than in the eastern sample (Table 4). These values are in good
10 agreement with the epidemiological study reporting the prevalence of 17% among Finnish speaking Finns with an increasing gradient from West to East². The same set of samples for the G/A-₂₂₀₁₈ polymorphism was also genotyped, and the LD between these two SNPs monitored using the D' statistic²¹. They were found to be in almost complete LD (D' = 0.98, $p = 7.62 \times 10^{-11}$, Table 5).

15

The prevalence of hypolactasia in different populations is known to vary greatly from less than 5% to almost 100%^{3,6}. To determine whether these changes in hypolactasia prevalence would correlate with the distribution of the genotype CC-₁₃₉₁₀, the DNA of the parents of CEPH families²² was analyzed. CEPH families have been mainly
20 collected from France, with reported prevalence of hypolactasia around 37%²³ and Utah, the Utah populations originating from Northern Europe with prevalence of hypolactasia less than 5%²⁴. Genotyping of the parents in CEPH families revealed that 41,2% (7 out of 17 samples) of French families have the genotype CC whereas only 7,6% (7 out of 92 samples) of Utah families have the genotype CC (Table 4).
25 Again, despite the small number of analyzed samples these figures agree with the values obtained in the epidemiological studies of hypolactasia in these populations^{23,24}.

Table 8 demonstrates that the observed prevalence of the variants well agrees with the described population frequencies of the lactose intolerance.

30

Example 6: The genealogy of the lactase persistence variant C/T₋₁₃₉₁₀

Haplotype analysis in the Finnish families suggested that most if not all, lactase persistence alleles in Finland have descended from one common ancestor. Linkage disequilibrium was used to estimate the time of the introduction of the persistence allele into the Finnish population²⁵. Assuming 20 years generation time, this estimate would indicate that the founder mutation was introduced into the Finnish population some 9000-11400 years ago (Table 6). This is in good agreement with earliest signs of settlement in the Finnish mainland some 8000-9000 years ago²⁶ and would reasonably well coincide with the beginning of the dairy farming in 8000-10.000 BC²⁷. More importantly, the presence of the same DNA-variant in persistence alleles in different populations would suggest that this variant is even more ancient and the mutation has occurred before differentiation of the analyzed populations.

To get some insight into the phylogenetic origin of the lactase allele, intron 9 and part of intron 13 of the *MCM6* gene of a Baboon (*Papio Hamadryas*) were sequenced. Genotype GG and CC was present in Baboons DNA at both G/A₋₂₂₀₁₈ and C/T₋₁₃₉₁₀. This could suggest that alleles G and C, respectively reflect the appearance of the ancestral allele, presenting the non-persistence type and a mutation has transformed this allele to create the persistence allele. This assumption is supported by the identification of the LD and shared haplotype in the persistence alleles versus a high diversity of alleles found in non-persistence alleles.

Example 7: Pairwise LD of C/T and G/A variants.

25

Pairwise LD between C/T₋₁₃₉₁₀ and G/A₋₂₂₀₁₈ was estimated using the D' statistic²¹. Haplotype frequencies were estimated by maximum likelihood using the EH program⁵⁰. D' is calculated as $\max(D/D_{\max}, D/D_{\min})$: where disequilibrium measure $D = h_{pq} - p q$, where h_{pq} is the frequency of the haplotype with rare allele at each locus, p and q are frequency of the rare alleles at loci 1 and 2, and $D_{\max} = \min p(1-p), q(1-q)$ if $D > 0$, and $D_{\min} = -\min pq, (1-p)(1-q)$ if $D < 0$. The significance of deviation of D' from 0 was

determined using the statistic $D^2 \sqrt{\frac{N}{p(1-p)q(1-q)}}$ which is distributed as χ^2 with 1 df²¹

Gene accessions numbers. For BACs NH0218L22, N0034L34, NH0318L13, and RP11-329110 are AC012551, AC011893, AC011999 and AC016516 respectively.

5 The accession numbers for human polymorphisms are GenBank AF395607-
AF395615.

References

- 10 1. Flatz, G. & Rotthauwe, H. The human lactase polymorphism: physiology and genetics of lactose absorption and malabsorption. *Prog. Med. Genet.* **2**, 205-249 (1977).
- 15 2. Sahi, T., Isokoski, M., Jussila, J. & Launiala, K. Lactose malabsorption in Finnish children of school age. *Acta Paediatr Scand.* **61**, 11-16 (1972).
3. Wang, Y. *et al.* The genetically programmed down-regulation of lactase in children. *Gastroenterology.* **114**:1230-1236 (1998).
- 20 4. Sahi, T., Isokoski, M., Jussila, J., Launiala, K. & Pyörälä, K. Recessive inheritance of adult-type lactose malabsorption. *Lancet.* 823-826 (1973).
5. Sahi, T. The inheritance of selective adult-type lactose malabsorption. *Scand. J. Gastroenterol. suppl.* **30**, 1-73(1974).
- 25 6. Sahi, T. Genetics and epidemiology of adult-type hypolactasia. *Scand. J. Gastroenterol. Suppl.* **202**, 7-20 (1994).
- 30 7. Boll, W., Wagner, P. & Mantei, N. Structure of the chromosomal gene and cDNAs coding for lactase-phlorizin hydrolase in human with adult-type hypolactasia or persistence of lactase. *Am. J. Hum. Genet.* **48**; 889-902 (1991).
8. Mantei, N. *et al.* Complete primary structure of human and rabbit lactase-phlorizin hydrolase: implications for biosynthesis, membrane anchoring and evolution of the enzyme. *EMBO J.* **7**, 2705-2713 (1988).
- 35 9. Wang, Y. *et al.* The lactase persistence/non-persistence polymorphism is controlled by a cis-acting element. *Hum. Mol. Genet.* **4**, 657-662 (1995).
- 40 10. Harvey, C.B., Pratt, W.S., Islam, I., Whitehouse, D.B. & Swallow, D.M. DNA polymorphisms in the lactase gene: linkage disequilibrium across the 70 kb region. *Eur J. Hum. Genet.* **3**, 27-41 (1995).
- 45 11. Escher, J.C *et al.* . Molecular basis of lactase levels in adult humans. *J. Clin. Invest.* **89**, 480-483 (1992).

12. Lloyd, M *et al.* Regulation of intestinal lactase in adult hypolactasia. *J. Clin. Invest.* **89**, 524-529 (1992).
- 5 13. Fajardo, O., Naim, H.Y. & Lacey, S.W. The polymorphic expression of lactase in adults is regulated at the messenger RNA level. *Gastroenterology* **106**, 1233-
14. Luigi, M. *et al.* Mosaic regulation of lactase in human adult-type *Gastroenterology* **112**, 1506-1514 (1997).
- 10 15. Rössli, M. *et al.* Lactase persistence versus decline in human adults: Multifactorial events are involved in down-regulation after weaning. *Gastroenterology* **112**, 1506-1514 (1997).
16. Göring, H.H.H. & Terwilliger, J.D. Linkage analysis in the presence of errors IV: Joint pseudomarker analysis of linkage and / or linkage disequilibrium on a mixture of pedigrees and singletons when mode of inheritance cannot be accurately specified. *Am. J. Hum. Genet.* **66**, 1310-1327 (2000).
- 20 17. Terwilliger, J.D. & Göring, H.H.H. Gene mapping in the 20th and 21st centuries: Statistical methods, data analysis, and experimental design. *Hum. Biol.* **72**, 63-132 (2000).
- 25 18. Harvey, C.B. *et al.* Regional localization of the lactase-phlorizin hydrolase, LCT, to chromosome 2q21. *Ann. Hum. Genet.* **57**, 179-185 (1993).
19. Syvänen, A-C., Sajantila, A., Lukka, M. Identification of individuals by analysis of biallelic DNA markers, using PCR and solid-phase minisequencing. *Am. J. Hum. Genet.* **52**, 46-59 (1993).
- 30 20. Syvänen, A-C. & Landegren, U. Detection of point mutations by solid-phase methods. *Hum. Mutat.* **3**, 172-179 (1994)
- 5 21. Thompson, E. A., Deeb, S., Walker, D. & Motulsky, A. G. The detection of Linkage disequilibrium between closely linked markers: RFLPs at the AI-CIII Apolipoprotein genes. *Am. J. Hum. Genet.* **42**, 113-124 (1998).
- 0 22. Dausset, J. *et al.* Centre d'étude du polymorphisme humain (CEPH): Collaborative genetic mapping of human genome. *Genomics* **6**, 575-577 (1990).
- 5 23. Cuddenech, Y., Delbrück, H. & Flatz, G. Distribution of the adult lactase phenotypes- lactose absorber and malabsorber- in a group of 131 army recruit *Gastroenterol. Clin. Biol.* **6**, 776-779 (1982).
24. McLellan, T., Jorde, L.B. & Skolnick, M.H. Genetic distance between the Utah Mormons and related populations. *Am. J. Hum. Genet.* **36**, 836-857 (1984).
- 25 25. Terwilliger, J.D. A powerful likelihood method for the analysis of linkage

- disequilibrium between trait loci and one or more polymorphic marker loci. *Am. J. Hum. Genet.* **56**, 777-787 (1995).
- 5 26. Nunez, M.G. A model of the early settlement of Finland. *Fennoscandia archaeologica IV*, 3-18 (1997).
- 10 27. Simoons, F.J. Primary adult lactose intolerance and the milking habit: a problem in biological and cultural interrelations.II. A cultural historical hypothesis. *Am. J. Dig. Dis.* **16**, 695-710 (1970).
28. Varilo, T. *et al* .The age of human mutation:genealogical and linkage disequilibrium analysis of the CLN5 mutation in the Finnish population. *Am. J. Hum. Genet.* **58**, 506-512 (1996).
29. Hästbacka, J. *et al* .Linkage disequilibrium mapping in isolated founder populations: diastrophic dysplasia in Finland. *Nature Genet.* **2**: 204-211 (1992).
- 20 30. Harvey C.B. *et al* .Lactase haplotype frequencies in Caucasians: association with the lactase persistence/non persistence polymorphism. *Ann Hum Genet* **62**, 215-223 (1998).
- 25 31. Ohtani, K. *et al* .Cell growth-regulated expression of mammalian MCM5 and MCM6 genes mediated by the transcription factor E2F. *Oncogene* **18**, 2299-2309 (1999).
32. Smith, A.F.A. The origin of interspersed repeats in the human genome. *Curr. Opin. Genet. Dev.* **6**, 743-748 (1996).
- 30 33. Kazazian, H.H. & Moran, J.V. The impact of L1 retrotransposons on the human genome. *Nature Genet.* **19**, 19-24 (1998).
34. Moran, J.V., DeBerardinis, R.J. & Kazazian, H.H. Exon shuffling by L1 retrotransposition. *Science* **283**, 1530-1534 (1999).
- 35 35. Wei, W. *et al* . Human L1 retrotransposition: *cis* preference versus *trans* complementation. *Mol. Cell. Biol.* **21**, 1429-1439 (2001).
- 40 36. Donnelly, S.R., Hawkins, T.E. & Moss, S.E. A conserved nuclear element with a role in mammalian gene regulation. *Hum. Mol. Genet.* vol.8, **9**,1723-1728 (1999).
37. Boeke, J.D. LINEs and Alus – the polyA connection. *Nature Genet.* **16**, 6-7 (1997).
- 45 38. Jurka, J. Sequence patterns indicate an enzymatic involvement in integration of mammals retroposons. *Proc. Natl. Acad. Sci. U.S.A.* **94**, 1872-1877 (1997).
39. Savilahti E, Launiala K, Kuitunen P. Congenital lactase deficiency. *Arch. Dis. Child.* **58**, 246-252 (1983).

40. Järvelä, I. *et al.* Assignment of the locus for congenital lactase deficiency to 2q21, in the vicinity of but separate from the lactase-phlorizin hydrolase gene. *Am. J. Hum. Genet.* **63**, 1078-1085 (1998).
- 5 41. Simoons, F. J. The geographic hypothesis and lactose malabsorption. A weighing of the evidence. *Am. J. Dig. Dis.* **23**, 963-980 (1978).
- 10 42. Flatz, G. & Rotthauwe, H, W. The human lactase polymorphism: physiology and genetics of lactose absorption and malabsorption. *Prog. Med. Genet.* **2**, 205-249 (1977).
43. McCracken, R.D. Lactase deficiency: an example of dietary evolution. *Curr. Anthropol.* **12**, 479-517 (1971).
44. Arola, H. *et al.* Diagnosis of hypolactasia and lactose malabsorption. *Scand. J. Gastroenterol. Suppl.* **202**, 26-35 (1994).
- 20 45. Sulkanen, S. *et al.* Tissue transglutaminase autoantibody enzyme-linked immunosorbent assay in detecting celiac disease. *Gastroenterology* **115** (6), 1322-1328 (1998).
- 25 46. Sambrook, J., Fritsch, E.F. & Maniatis, T. *Molecular cloning: a laboratory manual*, (2nd ed). Cold Spring Harbor Laboratory Press, Cold Spring Harbor, N.Y. (1989).
47. Messer, M. & Dahlqvist, A. A one - step ultramicro method for the assay of intestinal disaccharidases. *Anal. Biochem.* **14** (3), 376-92 (1966).
- 30 48. Cottingham, Jr. R.W., Idury, R.M. & Schaffer, A.A. Faster sequential genetic linkage computations. *Am. J. Hum. Genet.* **53**, 252-263 (1993).
- 35 49. Göring, H.H.H. & Terwilliger, J.D. Linkage analysis in the presence of errors III: Marker loci and their map as nuisance parameters. *Am. J. Hum. Genet.* **66**, 1298-1309 (2000).
50. Terwilliger, J.D. & Ott, J. Hand book of human genetic analysis. *Johns Hopkins University Press*, Baltimore (1994).
- 40 51. Osborne *et al.*, *Curr. Opin. Chem. Biol.* **1** (1997), 5-9
52. Stall and Szoka, *Pharm. Res.* **12** (1995), 465-483
- 45 53. Harlow and Lane „Antibodies, A Laboratory Manual“, CSH Press, Cold Spring Harbor, USA, 1988
54. Higgins and Hames (eds.), "Nucleic acid hybridization, a practical approach", IRL Press, Oxford 1985

55. Dib C, Faure S, Fizames C, Samson D, Drouot N, Vignal A, Millasseau P, Marc S, Hazan J, Seboun E, Lathrop M, Gyapay G, Morissette J, Weissenbach J. A comprehensive genetic map of the human genome based on 5,264 microsatellites. *Nature*. 1996 Mar 14;380(6570):152-4.
56. Chumakov IM, Rigault P, Le Gall I, Bellanne-Chantelot C, Billault A, Guillou S, Soularue P, Guasconi G, Poullier E, Gros I, et al. A YAC contig map of the human genome. *Nature*. 1995 Sep 28;377(6547 Suppl):175-297

Table 1. Linkage and Linkage Disequilibrium Analyses in adult-type hypolactasia families (fine mapping markers shown in bold)

Marker	Lod score(Z) at Θ					<i>p</i> -value ^a
	0.0	0.1	0.2	0.3	0.4	
D2S114	$-\infty$	2.44	1.92	1.13	0.41	0.87195
P6112	2.76	2.20	1.45	0.75	0.22	0.66207
D2S1334	3.15	2.45	1.61	0.84	0.25	0.91039
AC8	2.26	1.99	1.36	0.71	0.21	0.53670
LPH13	3.67	2.94	1.96	1.03	0.31	4x10 ⁻⁶
LPH2	4.09	3.07	2.00	1.00	0.26	5.7x10 ⁻⁷
LPH1	5.91	4.52	2.96	1.53	0.46	5x10 ⁻⁶
AC7	3.63	2.60	1.66	0.83	0.23	0.03471
AC3	6.63	4.88	3.16	1.61	0.44	3.2x10 ⁻⁸
AC4	3.07	2.22	1.42	0.71	0.19	4x10 ⁻⁵
AC5	5.33	4.10	2.72	1.39	0.39	0.02166
AC10	6.60	4.99	3.25	1.65	0.46	1x10 ⁻⁵
D2S2196	7.67	5.62	3.62	1.85	0.54	0.00010
D2S442	3.81	3.08	2.08	1.03	0.27	0.22805
D2S314	4.22	3.61	2.50	1.37	0.45	0.27535
D2S2385	$-\infty$	2.79	1.92	1.01	0.28	0.46457

a: *p*-values produced using linkage disequilibrium test given linkage^{16,49}

Table 2. The variations identified within adult-type hypolactasia locus in the Finnish Families

Position ^a	Variant	Lactase persistence (Homozygous)		Lactase persistence (Heterozygous)		Lactase non-persistence		
		BIV4	AIV3	BIV8	CIV3	BIV9	DIV4	EIII2 ^b
-694	A→G	AA	AA	AG	AA	GG	N ^c	AA
-1640/50	T ₁₃ →T ₁₂	T _{13/13}	T _{13/13}	T _{13/13}	T _{13/13}	T _{13/13}	T _{12/12}	T _{12/12}
-2131	C→T	CC	CC	CT	CC	TT	CT*	TT
-3058/72	T ₁₅ →T ₁₆	T _{15/15}	T _{15/15}	T _{15/15}	T _{15/15}	T _{15/15}	T _{16/16}	T _{16/16}
-3075	G→T	GG	GG	GG	GG	GG	GG	TT
-4480	T→A	TT	TT	TA	TT	AA	TT	TT
-5440	C→T	CC	CC	CT	CC	TT	CC	CC
-5926	A→T	AA	AA	AA	AA	AA	TA	TT
-8540	G→A	GG	GG	GA	GA	AA	AG	AA
-8630	C→G	CC	CC	CG	CG	GG	GC	GG
-13495	T→C	TT	TT	TC	TT	CC	CT	CC
-13910	T→C	TT	TT	TC	TC	CC	CC	CC
-15239	G→A	GG	GG	GA	GG	AA	AG	AA
-15862	T→C	CC	CC	CT	CC	TT	TC	TT
-16568/79	T ₁₁ →T ₁₂	T _{11/11}	T _{11/11}	T _{11/12}	T _{11/11}	T _{12/12}	T _{11/11}	T _{12/12}
-16888	A→G	AA	AA	GA	AA	GG	GA	GG
-17300	C→T	CC	CC	CC	CC	CC	CT	TT

-19044	T→C	TT	TT	TC	TT	CC	CT	CC
-19519	T→C	TT	TT	TC	TT	CC	TT	TT
-20077	C→G	CC	CC	CG	CC	GG	GC	GG
-20486	G→A	GG	GG	GA	GG	AA	GG	GG
-21721/28	A ₇ →A ₆	A _{7/7}	A _{7/7}	A _{7/7}	A _{7/7}	A _{7/7}	A _{7/A₆}	A _{7/7}
-21731	A→C	AA	AA	AA	AA	AA	CC	AA
-21736/43	A ₉ →A ₈	A _{9/9}	A _{9/9}	A _{9/A₈}	A _{9/9}	A _{8/8}	A _{8/8}	A _{8/8}
-22018	G→A	AA	AA	AG	AG	GG	GG	GG
-22741	C→T	CC	CC	CC	CC	CC	N	TT
-22788	A→G	AA	AA	AG	AA	GG	N	GG
-23069	A→G	AA	AA	AG	AA	GG	N	GG
-23442	A→G	AA	AA	AA	AA	AA	N	GG
-23771	T→C	TT	TT	TT	TT	TT	N	CC
-25093/23	Δ30 bp	Δ Δ	Δ Δ	Δ Δ	Δ Δ	Δ Δ	N	II
-27310	A→/G	AA	AA	AG	AA	GG	GA	GG
-27480	G→A	GG	GG	GA	GG	AA	AG	AA
-27807	A→C	AA	AA	AA	AA	AA	AC	CC
-30183	A→G	AA	AA	AG	AA	GG	AA	AA
-31268	A→G	AA	AA	AG	AA	GG	AA	AA
-31342	T→C	TT	TT	TT	TT	TT	CT	CC
-33645	C→T	CC	CC	CT	CC	TT	CC	CC
-35176	T→C	TT	TT	TC	TT	CC	CT	CC
-36254	C→T	CC	CC	CT	CC	TT	TC	TT

-36296	G→T	TT	TT	TG	TT	GG	TG	N
-36501	A→T	AA	AA	AT	AA	TT	AT	N
-36506/14	Δ 9 bp	ΔΔ	ΔΔ	Δ I	ΔΔ	II	ΔI	N
-36671/77	T7→T6	T _{7/7}	T _{7/7}	T _{7/6}	T _{7/7}	T _{6/6}	T _{7/7}	T _{7/7}
-37565	T→G	TT	TT	TG	TT	GG	GG	TG
-38276	G→C	GG	GG	GC	GG	CC	GG	GG
-39036	G→C	GG	N	GC	N	CC	N	N
-40608	G→C	GG	GG	GG	GG	GG	GC	CC
-41590	T→C	TT	TT	TC	TT	CC	CT	CC
-42081/82	ΔAG	AG	AG	AG/Δ	AG	ΔΔ	AG	AG
-42618	T→C	TT	TT	TC	TT	CC	TT	TT
-42893	G→A	GG	GG	GA	GG	AA	GG	GG

a: The Number is from initiation translation codon (ATG) of the LPH gene using the compiled genomic sequence of the BACs NH034L23, NH0218L22, NH0318L13 and RP11-329I10 , b: the individuals sequenced from the Finnish families studied and showed by arrow in fig.1, c: not determined

Table 3. Distribution of C/T₋₁₃₉₁₀ & G/A₋₂₂₀₁₈ genotypes in lactase persistent/non-persistent alleles

Genotype	C/T ₋₁₃₉₁₀			G/A ₋₂₂₀₁₈			Total
	CC	CT	TT	GG	GA	AA	
Family members							
Lactase non-persistence	45	0	0	45	0	0	45
Lactase persistence	0	32	13	0	32	13	45
Case-control samples							
Finnish							
Lactase non-persistence	59	0	0	53	6	0	59
Lactase persistence	0	63	74	0	63	74	137
Non-Finnish ^a							
Lactase non-persistence	40	0	0	39	1	0	40
Lactase persistence	0	5	0	0	5	0	5
Total							
Lactase non-persistence						0	144
Lactase persistence							187

a: non-Finnish samples consist of 23 South Korean, 9 Italian and 7 German individuals

Table 4. Prevalence of the C/T-13910 variant in population samples

DNA samples analysed	Genotype			Total	Allele		% (CC) genotype
	CC	CT	TT		frequency(%)		
					C	T	
I. Finnish population:							
1. Eastern regions	108	287	176	571	0.440	0.560	18.9%
2. Western regions	62	159	146	367	0.385	0.615	16.8%
Total	170	446	322	938	0.418	0.582	18.1%
II. CEPH parents:							
1. Utah families	7	33	52	92	0.255	0.745	7.6%
2. French families	7	9	1	17	0.676	0.324	41.2%

A total of 938 DNA samples of anonymous Finnish blood donors from small parishes from Eastern and Western parts within Finland, and 109 DNA samples from CEPH parents. The prevalence of hypolactasia in the populations is reflected by the genotype frequencies of CC alleles.

Table 5. LD between C/T-13910 and G/A-220018 variants in random Finnish samples

	Genotype at C/T-13910			Total	D'	χ^2 (1 df)	P-value
	CC	CT	TT				
Genotype at G/A-220018							
GG	162	2	1	165			
GA	6	440	3	449			
AA	2	4	318	324			
Total	170	446	322	938	0.984	42.41	7.62x10 ⁻¹¹

LD was calculated using D' statistic¹⁸, p value is the significance of D' from 0 as described in methods¹⁸.

Table 6. Estimation of the introduction of the C/T-13910 variant into Finnish population using DISLAMB program.

Marker	AC3		LPH2	
Allele	Lactase persistence	Lactase non-persistence	Lactase persistence	Lactase non-persistence
1	0	1	0	1
2	31	10	0	20
3	0	1	0	14
4	2	9	32	15
5	0	31	0	2
λ^a	0.838		0.999	
Θ^b	0.00031 (0,000038-0.00099)		0.0000(0.00000-0.00052)	
n^c	570		450	

a: λ is the proportion of increase of a certain allele in disease chromosomes (lactase persistence allele) relative to its population frequency(0.60). b: Θ is the recombination fraction , reflected by the distance of the mutation from the closest marker, assuming 1cM= 1Mb. C: n is the number of generation since the introduction of the founder mutation into a population Applying $\lambda = \infty (1-\Theta)^n$ formula. d: Hypothetical allele used in the calculations as Θ is zero and ∞ is one.

Table 7 Prevalence of lactose intolerance variants in biochemically verified samples

Population	Number	C/T ₁₃₉₁₀				G/A ₂₂₀₁₈			
		CC	CT	TT	GG	GA	AA		
1. Finnish	Lactase persistence	182	0	95	87	0	95	87	
	Lactase non-persistence	116	116	0	0	110	6	0	
2. Italian	Lactase persistence	7	0	7	0	0	7	0	
	Lactase non-persistence	23	23	0	0	22	1	0	
3. German	Lactase persistence	0	0	0	0	0	0	0	
	Lactase non-persistence	8	8	0	0	8	0	0	
4. Somalian	Lactase persistence	0	0	0	0	0	0	0	
	Lactase non-persistence	42	42	0	0	42	0	0	
6. South koreans	Lactase persistence	0	0	0	0	0	0	0	
	Lactase non-persistence	23	23	0	0	23	0	0	
Total		401	212	102	87	205	109	87	

Table 8 Prevalence of lactose-intolerance variants in various population samples

Population	Number	Genotype						%Prevalence of Lactase Persistence allele
		CT13910		G/A22018		AA		
		CC	CT	TT	GG	GA	AA	
South Koreans	23	23	0	0	23	0	0	*
France	17	7	9	1	6	10	1	*
Basques	85	7	44	34	13	35	37	*
Southern Italians	100	89	11	0	88	12	0	*
Somalians	79	74	5	0	78	1	0	6
Utah	92	7	33	52	7	30	55	92
AfricanAmericans	96	76	15	5	78	12	5	21
Marrocans	90	62	25	3	65	22	3	31
Sarawhi (African)	57	29	26	2	28	26	3	49
Saami	30	20	10	0	21	9	0	33
Tibet	23	23	0	0	23	0	0	0
Eastern Finnish	571	108	287	176	107	288	176	81
Western Finnish	367	62	159	146	58	161	148	83
Finn-ugrian tribes								
Xan	20	19	1	0	19	1	0	5
Xm	20	19	1	0	19	1	0	5
Mansi	22	20	2	0	20	2	0	9
Lkomi	10	7	3	0	7	3	0	30
Erza	30	17	10	3	19	9	2	43
Moksa	30	13	17	0	14	16	0	57
Udmort	30	12	16	2	11	15	4	60
Pakistani tribes								
Kalash	30	30	0	0	28	2	0	0

Table 8 cont

Burusho	30	29	1	0	27	3	0	3
Hazara	14	13	1	0	11	3	0	7
Kashmiri	20	15	5	0	14	6	0	25
Makrani Baluch	29	19	10	0	19	8	1	34
Brahui	30	17	10	3	16	11	3	43
Makrani (Negroid)	29	16	10	3	16	10	3	45
Pathan	29	12	16	1	13	14	2	59 *
Indian	29	11	13	5	10	12	5	62 *
Total	2032							

*The prevalence of lactase persistence allele is correlated very well with the reported prevalences for the lactase persistence allele (Simoons Fj. The geographic hypothesis and lactose malabsorption Am J Dig Dis 1978 23 (11):963-80)

Claims

1. A nucleic acid molecule comprising a 5' portion of an intestinal lactase-phlorizine hydrolase (LPH) gene contributing to or indicative of adult-type hypolactasia wherein said nucleic acid molecule is selected from the group consisting of
- 5
- (a) a nucleic acid molecule having or comprising the nucleic acid sequence of SEQ ID NO: 1, the sequence of SEQ ID NO:1 is also depicted in Fig. 4 and comprised in the sequence as depicted in Fig. 8;
- 10
- (b) a nucleic acid molecule having or comprising the nucleic acid sequence of SEQ ID NO: 2, the sequence of SEQ ID NO:2 is also depicted in Fig. 5 and comprised in the sequence as depicted in Fig. 9;
- (c) a nucleic acid molecule of at least 20 nucleotides the complementary strand of which hybridizes under stringent conditions to the nucleic acid molecule of (a) or (b), wherein said polynucleotide/nucleic acid molecule has at a position corresponding to position -13910 5' from the LPH gene a cytosine residue; and
- 15
- (d) a nucleic acid molecule of at least 20 nucleotides the complementary strand of which hybridizes under stringent conditions to the nucleic acid molecule of (a) or (b), wherein said polynucleotide/nucleic acid molecule has at a position corresponding to position -22018 5' from the LPH gene a guanine residue.
- 20
2. A nucleic acid molecule comprising a 5' portion of an intestinal lactase-phlorizine hydrolase (LPH) gene wherein said nucleic acid molecule is selected from the group consisting of
- 25
- (a) a nucleic acid molecule having or comprising the nucleic acid sequence of SEQ ID NO:3, the sequence of SEQ ID NO:3 is also depicted in Fig. 6;
- 30
- (b) a nucleic acid molecule having or comprising the nucleic acid sequence of SEQ ID NO:4, the sequence of SEQ ID NO:4 is also depicted in Fig. 7;
- (c) a nucleic acid molecule the complementary strand of which hybridizes

under stringent conditions to the nucleic acid molecule of (a) or (b), wherein said polynucleotide/nucleic acid molecule has at a position corresponding to position -13910 of the LPH gene a thymidine residue; and

- 5 (d) a nucleic acid molecule the complementary strand of which hybridizes under stringent conditions to the nucleic acid molecule of (a) or (b), wherein said polynucleotide/nucleic acid molecule has at a position corresponding to position -22018 of the LPH gene a adenosine residue.
- 10 3. The nucleic acid molecule of claim 1 or 2 which is genomic DNA.
4. The nucleic acid molecule of claim 3 wherein said genomic DNA is part of a gene.
- 15 5. A fragment of the nucleic acid molecule of any one of claims 1 to 4 having at least 14 nucleotides wherein said fragment comprises nucleotide position -13910 or nucleotide position -22018 of the LPH gene.
- 20 6. A nucleic acid molecule which is complementary to the nucleic acid molecule of any one of claims 1 and 3 to 5.
7. A nucleic acid molecule which is complementary to the nucleic acid molecule of any one of claims 2 to 5.
- 25 8. A vector comprising the nucleic acid molecule of any one of claim 1 and 3 to 5.
9. A vector comprising the nucleic acid molecule of any one of claims 2 to 4.
- 30 10. A primer or primer pair, wherein the primer or primer pair hybridizes under stringent conditions to the nucleic acid molecule of any one of claims 1 and 3 to 5 comprising nucleotide position -13910 or -22018 of the LPH gene or to the complementary strand thereof.

11. A primer or primer pair, wherein the primer or primer pair hybridizes under stringent conditions to the nucleic acid molecule of any one of claims 2 to 5 comprising nucleotide position -13910 or -22018 of the LPH gene or to the complementary strand thereof.
- 5
12. A non-human host transformed with the vector of claim 6.
13. A non-human host transformed with the vector of claim 7.
- 10 14. The non-human host of claim 12 or 13 which is a bacterium, a yeast cell, an insect cell, a fungal cell, a mammalian cell, a plant cell, a transgenic animal or a transgenic plant.
- 15 15. An antibody or aptamer or phage that specifically binds to the wild-type nucleic acid molecule of any one of claims 1 and 3 to 6 but not to the corresponding wild-type nucleic acid molecule
- 20 16. An antibody or aptamer or phage that specifically binds to the wild-type nucleic acid molecule of any one of claims 2 to 5 and 7 but not to the corresponding mutant sequence contributing to or indicative of adult-type hypolactasia.
7. A pharmaceutical composition comprising the wild-type nucleic acid molecule of claim 2, 3, 4 or the vector of claim 9.
- 25 18. A diagnostic composition comprising the nucleic acid molecule of any one of claims 1 to 7, the vector of claim 8 or 9, the primer or primer pair of claim 11 or 12, and/or the antibody aptamer and/or phage of claim 15 or 16.
- 30 19. A method for testing for the presence or predisposition of adult-type hypolactasia or associated trait comprising testing a sample obtained from a prospective patient or from a person suspected of carrying such a predisposition for the presence of the nucleic acid molecule of any one of claims 1 and 3 to 6 in a homozygous or heterozygous state.

20. A method for testing for the presence or predisposition of adult-type hypolactasia or associated trait comprising testing a sample obtained from a prospective patient or from a person suspected of carrying such a predisposition for the presence of the nucleic acid molecule of any one of claims 2 to 5 and 7 in a homozygous or heterozygous state.
21. The method of claim 19 or 20, wherein said testing comprises hybridizing the complementary nucleic acid molecule of claim 6 which is complementary to the nucleic acid molecule contributing to or indicative of adult-type hypolactasia or the nucleic acid molecule of claim 7 which is complementary to the wild-type sequence as a probe under stringent conditions to nucleic acid molecules comprised in said sample and detecting said hybridization.
22. The method of any one of claims 19 or 21 further comprising digesting the product of said hybridization with a restriction endonuclease or subjecting the product of said hybridization to digestion with a restriction endonuclease and analyzing the product of said digestion.
23. The method of claim 21, wherein said probe is detectably labeled.
24. The method of claim 19 or 20, wherein said testing comprises determining the nucleic acid sequence of at least a portion of the nucleic acid molecule of any one of claims 1 to 7, said portion comprising nucleotide position -13910 and/or nucleotide position -22018 of the LPH gene.
25. The method of claim 24, wherein the determination of the nucleic acid sequence is effected by solid-phase minisequencing.
26. The method of claim 24 further comprising, prior to determining said nucleic acid sequence, amplification of at least said portion of said nucleic acid molecule.

27. The method of claim 19 or 20, wherein said testing comprises carrying out an amplification reaction wherein at least one of the primers employed in said amplification reaction is the primer of claim 10 or belongs to the primer pair of claim 10, comprising assaying for an amplification product.
- 5
28. The method of claim 19 or 20, wherein said testing comprises carrying out an amplification reaction wherein at least one of the primers employed in said amplification reaction is the primer of claim 11 or belongs to the primer pair of claim 11, comprising assaying for an amplification product.
- 10
29. The method of any one of claims 26 to 28 wherein said amplification is effected by or said amplification is the polymerase chain reaction (PCR).
30. A method for testing for the presence or predisposition of adult-type hypolactasia comprising assaying a sample obtained from a human for specific binding to the antibody or aptamer or phage of claim 15
- 15
31. A method for testing for the presence or predisposition of adult-type hypolactasia comprising assaying a sample obtained from a human for specific binding to the antibody or aptamer or phage of claim 16.
- 20
32. The method of claim 30 or 31, wherein said antibody or aptamer or phage is detectably labeled.
- 25
33. The method of any one of claims 30 to 32, wherein the test is an immuno-assay.
- 30
34. The method of any one of claims 19 to 33, wherein said sample is blood, serum, plasma, fetal tissue, saliva, urine, mucosal tissue, mucus, vaginal tissue, fetal tissue obtained from the vagina, skin, hair, hair follicle or another human tissue.

35. The method of any one of claims 19 to 34, wherein said nucleic acid molecule from said sample is fixed to a solid support.
36. The method of claim 35, wherein said solid support is a chip, a silica wafer, a bead or a microtiter plate.
37. Use of the nucleic acid molecule of any one of claims 1 to 7 for the analysis of the presence or predisposition of adult-type hypolactasia.
38. Kit comprising the nucleic acid molecule of any one of claims 1 to 7, the primer or primer pair of claim 11 or 12, the vector of claim 8 or 9, and/or the antibody aptamer and/or phage of claim 15 or 16 in one or more containers.
39. Use of the nucleic acid molecule of any one of claims 2 to 4 or the vector of claim 7 in gene therapy.
40. The use of claim 39, wherein said gene therapy treats or prevents adult-type hypolactasia.

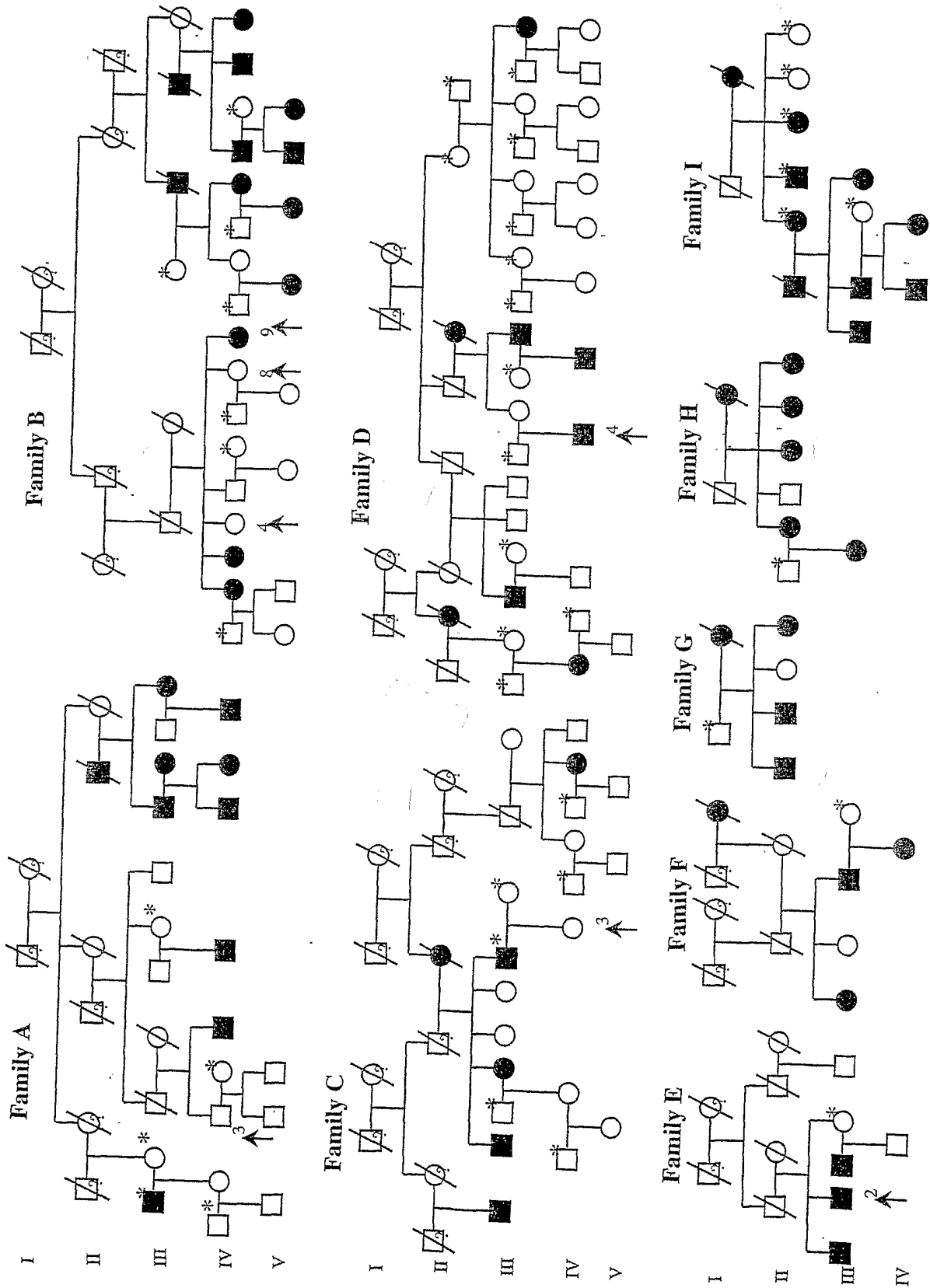

Figure 1

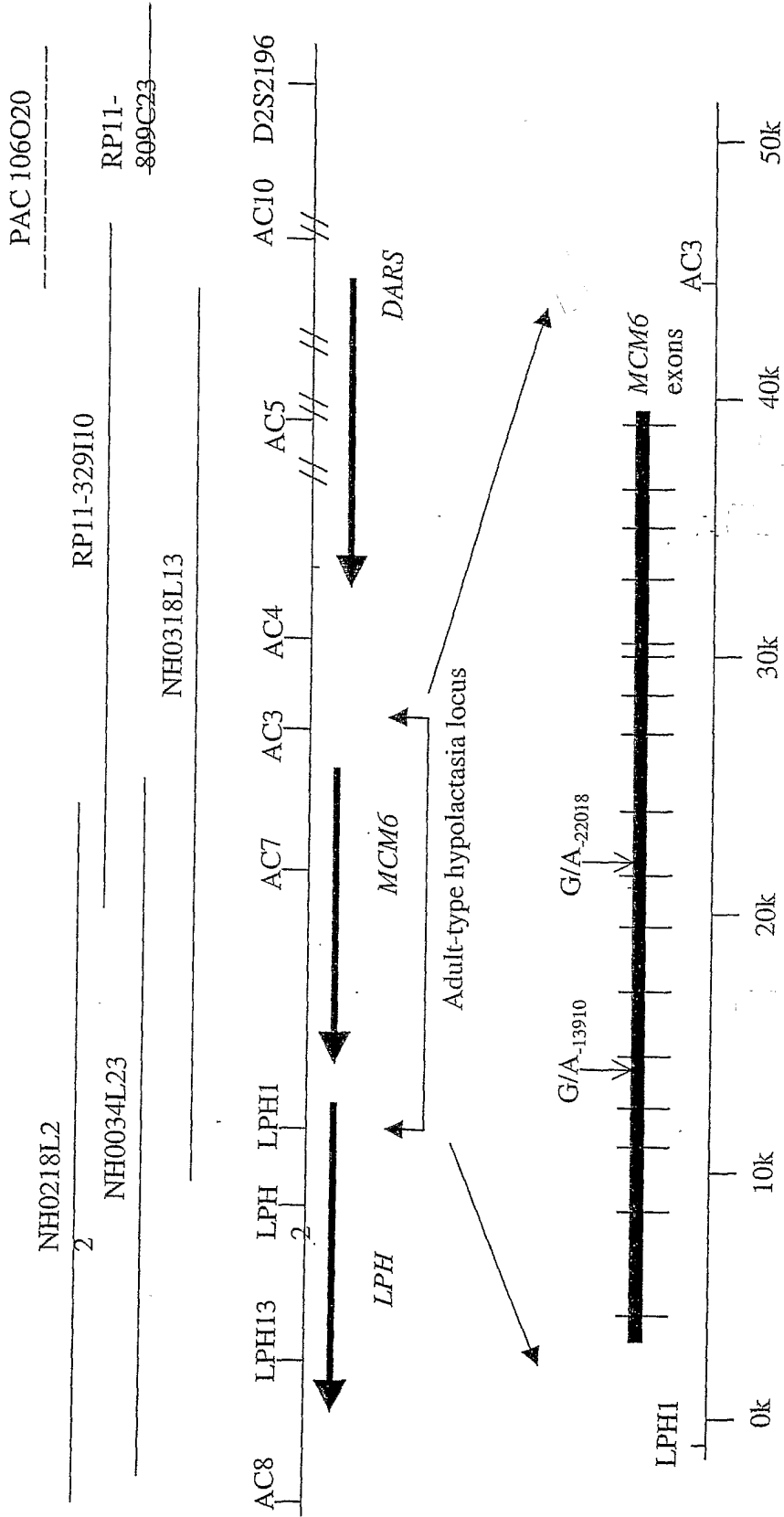

Figure 2

Marker	Haplotype										Total	
	6	6	6	6	6	6	6	6	6	6		
LPH13	6	6	6	6	6	6	6	6	6	6	6	6
LPH2	4	4	4	4	4	4	4	4	4	4	4	4
LPH1	3	2	2	2	1	1	4	4	4	4	4	4
AC7	5	5	5	5	5	5	5	5	5	5	5	5
AC3	2	2	2	4	2	2	2	2	2	2	2	2
AC4	5	5	5	5	5	5	5	5	5	5	5	5
AC5	6	6	5	6	6	6	6	6	6	6	6	6
Lactase persistent alleles	20	4	1	2	2	1	1	1	1	1	1	33
Lactase non-persistent alleles	3	2	0	0	0	0	2	0	2	0	2	54

Figure 3

4 /10

SEQ ID NO:1

ACCTTTCATTCAGGAAAAATGTA
CTTAGACCCTACAATGTA
CTAGTAGGCCTCTGCGCTG
GCAATACAGATAAGATAATG
TAGcCCCTGGCCTCAAAGG
AACTCTCCTCCTTAGGTTG
CA
TTTGTATAATGTTTGATTTT
TAGATTGTTCTTTGAGCCCT
GCATTCCACGAGGATAGGTC

Figure 4

SEQ ID NO:2

TAAGAACATTTTACACTCTTC
AGTATAAAGAAGTCAGAATA
CCCCTACCCTATCAGTAAA
GGCCTATAAGTTACCATTAAA
AAGATGTCCTTAAAAACAG
CATTCTCAGCTGGGCgCGGT
GGCTCACACCTTTGTCCCAG
TACTTTGGGAAGCCGAGGT
GGGTGGATCACCTGAGGTCAG

Figure. 5

5 / 10

SEQ ID NO:3

ATCAGAGTCACTTTGATATGATGAGAGCAGAGATAAACAGATTTGTTGCATGTTTTTAAT
CTTTGGTATGGGACATACTAGAATTCAGTGC AAAATACATTTTTATGTAACCTGTTGAATGC
TCATACGACCATGGAATTCCTCCCTTTAAAGAGCTTGGTAAGCATTTGAGTGTAGTTGTT
AGACGGAGACGATCACGTCATAGTTTATAGAGTGCATAAAAGACGTAAGTTACCATTTAAT
ACCTTTCATTCAGGAAAAATGTACTTAGACCCTACAATGTACTAGTAGGCCCTCTGCGCTG
GCAATACAGATAAGATAATGTAGTCCCTGGCCTCAAAGGAACTCTCCTCCTTAGGTTGCA
TTTGTATAATGTTTGATTTTTAGATTGTTCTTTGAGCCCTGCATTCCACGAGGATAGGTC
AGTGGGTATTAACGAGGTAAAAGGGGAGTAGTACGAAAGGGCATTCAAGCGTCCCATCTT
CGCTTCAACCAAAGCAGCCCTGCGTTTTCTAGTTTTTATTAATAGGTTTGATGTAAGGTC
GTCCTTTGAAAAGGGGGTTTTGGCTTTTTTTTACAGTGTGACTGAGGTATAATTTATAAAAA
GGGAAATGTATGGCATGGTGAGTTTTTTTACATACATCCTTGTGAATACCCAGCTCAAGA
TCCAAAACATTTCCATAATTTCCAGAAAGTTCCAAACCCCTGCCTCTTTTCAGTCTTAGCC
CTCTTCCCCTGAAGTAACCACTGTTCCGACTTCAATCACTACTTTTATCCCACAGGTTAA
TTTTTTGGCTTTTTTCCACTAAATTTTCAAATTCCTTGATATGGTACTTTACTATTGACG
AAGTACTTTCACACTAGGTTATTTAATATTCCTTTGATTCACCCAATATTTAGGGAACACC
TGTAGGGGACAAAAAATGAATGAGAGCCCCTGCCTTCCATTGCTGCTAATCTGGTGGGAA
CGAGACATGTATTTAATTAAGCATGTAAAAAATAGAGTGGGTGATGAAATAATCTATATA
CTAAATCCCATGACACACAGTTTACCTATGTAACAAACCTGCATGTGTACCCCGAACC
TAAAATATAAGTTGGAAATTAAAAAAAAACGAGAGGGAGAATAGAGCATCACAACCAGAG
TGCTGAGATGAATTACTTTATTACCAAAGAAGGAGGAGGACTCAGGGAGGTGCCGACGTT
TAAACCCAGTCACTGAAGGGTGTGCAGAATTTGGATAGGCAAGATACCCTGGGACAAGGT
CATTCTAAAACCATGCTAACATTTGTACTTTTTTTTTTCATTGTGATAGTTCCTGAAATGA
GTTGCATAAAACTGGTACATGTCTTAGGGCAGTCTCTAATTGATTTTTTATTTTGTCTAT
TTTTAAAAATTAGTCTTCAAATAGCAGATTCACATGATATTAATAATATATGCACATAAAT
TATATACACAAATATATTTTCTGAATGAAATTTAGTATCTGCATATATTTAAGAGCTATT
TCTGTCTCATATGTTCCATAATCTTCATCCATTAAAAAAACTTTTGTTAGGCCTTCTCAC
TCTAAGATTATAAAAAAATCTCCCATTATTTACCTAGCTAGTTTTCTAGTTGTTCCAAAA
CCATTTATTGAACAATCCATCTTTTTGACACTGGTGTGGCATGCCTTAATTATATATTCT
TGTGTGTGTTAGGATCTCCTTTTGGACTTTCATTCTGTTTATTGAGTCTTATCAGCTCC
TCTTACATTGGTACCATGATGTTTTAATCTATGGGGCTTTGTAGTTTAAATGTAGGGCTA
GTTCCAGCGCATTGTTCTCTATCAGCTGTTAGGAACTTAGAAATCAGCTTGCTCTGTTTT
AAAGAAAAACCTGGTATTTTTTTTATCAGTATAACATTCATTTATATTAACCTGAAGAAT
TGAAAACATCTATGATTTTTCTTATTCAGTAACGTATCACTTAGAATAGGTTAGGTTGTA
CTACTATAAAATCTCAGCTGCATAAAAACAATTTTTTTTTGCTTGTGCTACACATCCATTA
GGTCATCAAGGGACTCACCTTGTCAAGTTACTCAGAGATTCAGGCTGATATAAAGGTTTG
ATCTTGACATACGCTTTCATGATGACAGAAAGCAGGGGAAGAGAAGGTGGTGAGCCATGTG
CTTTCTCCCCCTTCTATCCAGAAATGACACATACTCACATTCATTGCGCCAGAGAAATTA
ACATGGCCCCCTCCTAAGTTCAAATGGATAGAGAAATGCCTTCCCTACCAGGTGCCCAGAAT
TAGAAGAGCAAACATTTGTGAACAGTCTGAGTACCACAAATACCGTTATCTTTCCACTT
AAGTCTTCTGTTTCACTCAGTAGTGCTTTAAACTTTTTCTTCATATGTTTTTTCAGTGTTC
TTGTTGAATTTCTTGATATTTTATCATGTTTGTTCGTAAGTGGGAGTAGCCTTTTTTTCCA

Figure. 6

6 / 10

TTTCATTTTCTGGCTGGTTTCATTGCTGGTTGTTTTTTTGTGTTTTGTTTTGTTTTGAGAT
GGAGTCTCACTCTGTCGCCCAGGCTGGAGTGCAGTGTCACAATCTCGGCTCACTGCAACC
TCTGCCTCCCAGGTTCAAGCGATTCTTCTTTCTCAGCCTCCTGAGTAGCTGGGATTACAG
GCATGTGCCACCATGCCAGCTAATTTTTTATATTTTATAGTAGAGATGGGGTTTCTCCAT
GTTGGTCAGGCTGGTCTCAAACCTCCAATCTCAGGTGATCCGCCTGCCTCTGCCTTCCAA
AGTGTGGGATTATAGACATGAGCCACCGTGCCTGGCCTAGTTCTTATGGGATGTATATG
TCTTTGGATTTCATATGATATGTATATATGTTTATATTTCTACAAGTACATACCTAGGAGT
GGAATTGTTGGGTCATAGGTTAATGCATGTTTTTCTGCCAAACAGTTGTGTCAATTTCTG
TTTTCACCGCTGTGAATGAGAGTTGTTCTACCTTCTTGACAACACTTGATATGTCAGTC
ATTTTAGCCATTCTGGTGAATTTATAGTGCTATTTCTGTGTGTGTAAGAGAGAGAATGAG
AGAGGGTGTGTTGTGAGAAAACCAAAGCAACACTGTGAGAGTGTGTGTGTTTGTGAGAAA
CCAAAATACATACTACTGTGATTTTCATTGGGAGAAAATCTGTTTGGTATATCAAAAAAG
TAGCTTAATTACTTCATCATTATTGGTTTAGGT

Figure. 6 .cont

7 / 10

SEQ ID NO:4

TAAGAACATTTTACACTCTTCAGTATAAAGAAGTCAGAATACCCCTACCCTATCAGTAAA
GGCCTATAAGTTACCATTA AAAAGATGTCTTAAAAACAGCATTCTCAGCTGGGCaCGGT
GGCTCACACCTTTGTCCCAGTACTTTGGGAAGCCGAGGTGGGTGGATCACCTGAGGTCAG
GAGTTCGAGACCAGCCTGGCCAACATGGCGAAAACCCATTTTCTCTACTAAAAATACAAA
AATTAGCCGGGCATGGTGGCGGGTGTCTGTGGTCCCAGCTACTCAAGAGGCTGAGGTGGG
AGGATCACTGAGCCCAGGAGGTGGAGGCTGCATTGAGCCAAGATTGTGCCACTGCACTCC
AGCCTGGGTGACAGAGCGAGACTCTGTCTCAAAAAACCAAAACAAAAAAACCCAGCAT
TCTTTAGTAAATAATTCATAGTTTCTTCATCTAGAATTTAAATTTGTGATAGTTGATCA
GCATGTCTGAGCACGTGTGTTTGCTGTTACTAGTTTAGATCGGTAGATGTGTATATAAG
TTATAGGTATAAAATCAATCCTGAGTTGACACAAGGTTTGTGATGTTGAGTACAAGTACAG
TAAGTGTATATTTT TAGTTATGCTCTTAGTTTAAAGTCAATTGTGTGGTCTTTCTAGCT
TTAGGATCTGTTGAATTATCTTCCTTAGAAAAGGGAGTTAAGAATCTTCACTTACCTATC
TTCTACTTGTTTGGAGAATAGAAGAGTCCCTGTGGTAGCAGACTTTGTGAGTTTACTTGT
AATTTTCCATCTGAAAGACTGTTCTTGTTTTTCGTGATGAAGTCTTGCTCTGTGCGCCAG
GCTGGAGTGCAGTGGTGCAACCTTGGCTCACTGCAACCTCTGCCTCCCGGGTTCAAGCAA
TTCTCCTGCCTCAGCCTCCCGAGTATCTGGGATTACAGGTGCACACCACCACACCTGGCT
AATTTTGTATTTTCAGTAGAGACGGGGTTTACCATGTTGGCCAGGCTGGTCTCGAACT
CTTGACCTCATGATCAGCCACCTCAGCCTTCCAAAGTGCTGGGATTACAGGTGTGAGCC
CCCACACTCGGCCGTTGTTGTTTTTAAAGAGACAGGGTCTCACTCTGTCACCTAACCTGG
AGTACAGTGGCAATCATGGCTCACTGTAACCTCAAATGCCCGGCCTTAGTGAAGCGTTCT
TCCTGCCTTGGCCTCCCAAAGTGCTGGGATTACAAGTGTGAGCCATGCATCCAGCTTGAA
AGACAGCTTCTTAGGCTTGATTTGTTTGGTTACAGG

Figure. 7

SEQ ID NO:5

ATCAGAGTCACTTTGATATGATGAGAGCAGAGATAAACAGATTTGTTGCATGTTTTTAAT
 CTTTGGTATGGGACATACTAGAATTCAGTGC AAAATACATTTTTTATGTAAGTGTGAAATGC
 TCATACGACCATGGAATTCCTCCCTTTAAAGAGCCTGGTAAGCATTTGAGTGTAGTTGTT
 AGACGGAGACGATCACGTCATAGTTTATAGAGTGCATAAAGACGTAAGTTACCATTTAAT
 ACCTTTCATTCAGGAAAAATGTACTTAGACCCTACAATGTACTAGTAGGCCTCTGCGCTG
 GCAATACAGATAAGATAATGTAGCCCTGGCCTCAAAGGAACTCTCCTCCTTAGGTTGCA
 TTTGTATAATGTTTGATTTTTAGATTGTTCTTTGAGCCCTGCATTCACGAGGATAGGTC
 AGTGGGTATTAACGAGGTA AAAAGGGGAGTAGTACGAAAGGGCATTCAAGCGTCCCATCTT
 CGCTTCAACCAAAGCAGCCCTGCGTTTTTCTAGTTTTTATTAATAGGTTTGATGTAAGGTC
 GTCTTTGAAAAGGGGGTTTTGGCTTTTTTTTACAGTGTGACTGAGGTATAATTTATAAAAA
 GGGAAATGTATGGCATGGTGAGTTTTTTCACATACATCCTTGTGAATACCCAGCTCAAGA
 TCCAAAACATTTCCATAATTTCCAGAAAGTTCCAAACCCCTGCCTCTTTTCAGTCTTAGCC
 CTCTTCCCCTGAAGTAACCACTGTTCCGACTTCAATCACTACTTTTATCCCACAGGTTAA
 TTTTTTGGCTTTTTTCCACTAAATTTTTCAAATTCCTTGATATGGTACTTTACTATTGACG
 AAGTACTTTCACACTAGGTTATTTAATATTCCTTGATTCACCCAATATTTAGGGAACACC
 TGTAGGGGACAAAAAATGAATGAGAGCCCCTGCCTTCCATTGCTGCTAATCTGGTGGGAA
 CGAGACATGTATTTAATTAAGCATGTAAAAAATAGAGTGGGTGATGAAATAATCTATATA
 CTAAATCCCCTGACACACAGTTTACCTATGTAAACAAACCTGCATGTGTACCCCCGAACC
 TAAAATATAAGTTGGAAATTA AAAAAAAAAACGAGAGGGGAGAATAGAGCATCACAACCAGAG
 TGCTGAGATGAATTACTTTATTACCAAAGAAGGAGGAGGACTCAGGGAGGTGCCGACGTT
 TAAACCCAGTCACTGAAGGGTGTGCAGAAATTTGGATAGGCAAGATACCCTGGGACAAGGT
 CATTCTAAAACCATGCTAACATTTGTACTTTTTTTTTTTCATTGTGATAGTTCCCTGAAATGA
 GTTGCATAAAACTGGTACATGTCTTAGGGCAGTCTCTAATTGATTTTTATTTTGTCTAT
 TTTTAAAAATTAGTCTTCAAATAGCAGATTCACATGATATTA AAAATATATGCACATAAAT
 TATATACACAAAATATATTTTCTGAATGAAATTTAGTATCTGCATATATTTAAGAGCTATT
 TCTGTCTCATATGTTTCATAATCTTCATCCATTA AAAAAACTTTTTGTTAGGCCTTCTCAC
 TCTAAGATTATAAAAAATCTCCCATTATTTACCTAGCTAGTTTTCTAGTTGTTCCAAAA
 CCATTTATTGAACAATCCATCTTTTTTGACACTGGTTTTGGCATGCCTTAATTATATATTCT
 TGTGTGTGTTAGGATCTCCTTTTTGGACTTTCCATTCTGTTTCATTGAGTCTTATCAGCTCC
 TCTTACATTGGTACCATGATGTTTTAATCTATGGGGCTTTGTAGTTTAAATGTAGGGCTA
 GTTCCAGCGCATTTGTTCTCTATCAGCTGTTAGGAACCTTAGAAATCAGCTTGCTCTGTTTT
 AAAGAAAACCTGGTATTTTTTTTATCAGTATAACATTTCTATTTATATTAACCTGAAGAAT
 TGAAAACATCTATGATTTTTTCTATTTCAGTAACGTATCACTTAGAATAGGTTAGGTTGTA
 CTACTATAAAAATCTCAGCTGCATAAAACAATTTTTTTTTTGCTTGTGCTACACATCCATTA
 GGTCATCAAGGGACTCACCTTGTCAAGTTACTCAGAGATTCAGGCTGATATAAAGGTTTG
 ATCTTGACATACGCTTTCATGATGACAGAAAGCAGGGAAGAGAAGGTGGTGAGCCATGTG
 CTTTCTCCCCCTTCTATCCAGAAATGACACATACTCACATTTTCATTGCGCCAGAGAAATTA
 ACATGGCCCCCTCCTAAGTTCAAATGGATAGAGAAATGCCTTCCCTACCAGGTGCCCAGAAT
 TAGAAGAGCAAACATTTGTGAACAGTTCTGAGTACCACAAATACCGTTATCTTTCCACTT
 AAGTCTTCTGTTTCACTCAGTAGTGCTTTAAACTTTTCTTCATATGTTTTTTCAGTGTTC
 TTGTTGAATTTCTTGATATTTTATCATGTTTGTTCGTA CTGGGAGTAGCCTTTTTTTCCA

Figure. 8

9 / 10

TTTCATTTTCTGGCTGGTTTCATTGCTGGTTGTTTTTTGTTTTGTTTTGTTTTGAGAT
GGAGTCTCACTCTGTGCGCCAGGCTGGAGTGCAGTGCACAATCTCGGCTCACTGCAACC
TCTGCCTCCCAGGTTCAAGCGATTCTTCTTTCTCAGCCTCCTGAGTAGCTGGGATTACAG
GCATGTGCCACCATGCCAGCTAATTTTTTATATTTTATAGTAGAGATGGGGTTTCTCCAT
GTTGGTCAGGCTGGTCTCAAAC TCCAATCTCAGGTGATCCGCCTGCCTCTGCCTTCCAA
AGTGCTGGGATTATAGACATGAGCCACCGTGCCTGGCCTAGTTCTTATGGGATGTATATG
TCTTTGGATT CATATGATATGTATATATGTTTATATTTCTACAAGTACATACCTAGGAGT
GGAATTGTTGGGTCATAGGTTAATGCATGTTTTTCTGCCAAACAGTTGTGTCAATTTCTG
TTTTACCCGCTGTGAATGAGAGTTGTTCTACCTTCTTGACAACACTTGATATTGTCAGTC
ATTTTAGCCATTCTGGTGAATTTATAGTGCTATTTCTGTGTGTGTAAGAGAGAGAATGAG
AGAGGGTGT TTTGTGAGAAAACCAAAGCAACACTGTGAGAGTGTGTGTGTTTGTGAGAAA
CCAAAATACATACTACTGTGATTTTCATTGGGAGAAAATCTGTTTGGTATATCAAAAAAAG
TAGCTTAATTACTTCATCAT TATTGGTTTAGGT

Figure. 8 cont.

10 / 10

SEQ ID NO:6

TAAGAACATTTTACACTCTTCAGTATAAAGAAGTCAGAATACCCCTACCCTATCAGTAAA
GGCCTATAAGTTACCATTAAAAAGATGTCCTTAAAAACAGCATTCTCAGCTGGGCgCGGT
GGCTCACACCTTTGTCCCAGTACTTTGGGAAGCCGAGGTGGGTGGATCACCTGAGGTCAG
GAGTTCGAGACCAGCCTGGCCAACATGGCGAAAACCCATTTTCTCTACTAAAAATACAAA
AATTAGCCGGGCATGGTGGCGGGTGTCTGTGGTCCCAGCTACTCAAGAGGCTGAGGTGGG
AGGATCACTGAGCCAGGAGGTGGAGGCTGCATTGAGCCAAGATTGTGCCACTGCACTCC
AGCCTGGGTGACAGAGCGAGACTCTGTCTCAAAAAAACAAAAACAAAAAACCCAGCAT
TCTTTAGTAAATAATTCATAGTTTTCTTCATCTAGAATTTAAAATTGTGATAGTTGATCA
GCATGTCCTGAGCACGTGTGTTTGCTGTTACTAGTTTAGATCGGTAGATGTGTATATAAG
TTATAGGTATAAAATCAATCCTGAGTTGACACAAGGTTTTGATGTTGAGTACAAGTACAG
TAAGTGTATATTTTTAGTTATGCTCTTAGTTTTAAGTCAATTGTGTGGTTCTTTCTAGCT
TTAGGATCTGTTGAATTATCTTCCTTAGAAAAGGGAGTTAAGAATCTTCACTTACCTATC
TTCTACTTGTTTGGAGAATAGAAGAGTCCCTGTGGTAGCAGACTTTGTGAGTTTACTTGT
AATTTTCCATCTGAAAGACTGTTCTTGTTTTTTCGTGATGAAGTCTTGCTCTGTGCGCCAG
GCTGGAGTGCAGTGGTGCAACCTTGGCTCACTGCAACCTCTGCCTCCCGGGTTCAAGCAA
TTCTCCTGCCTCAGCCTCCCGAGTATCTGGGATTACAGGTGCACACCACCACACCTGGCT
AATTTTGTATTTTCAGTAGAGACGGGGTTTACCATGTTGGCCAGGCTGGTCTCGAACT
CTTGACCTCATGATCAGCCCACCTCAGCCTTCCAAAGTGCTGGGATTACAGGTGTGAGCC
CCCACACTCGGCCGTTGTTGTTTTTTAAGAGACAGGGTCTCACTCTGTCACCTAACCTGG
AGTACAGTGGCAATCATGGCTCACTGTAACCTCAAATGCCCGGCCTTAGTGAAGCGTTCT
TCCTGCCTTGGCCTCCCAAAGTGCTGGGATTACAAGTGTGAGCCATGCATCCAGCTTGAA
AGACAGCTTCTTAGGCTTGATTTGTTTGGTTACAGG

Figure. 9

SEQUENCE LISTING

<110> National Public Health Institute
PELTONEN, Leena
ENATTAH, Nabil
JÄRVELÄ, Irma
SAHI, Timo
SAVILAHTI, Erkki
TERWILLIGER, Joseph

<120> Identification of a DNA variant associated with adult type hypolactasia

<130> F 2034 PCT

<150> EP 01 11 9377.8
<151> 2001-08-10

<150> EP 01 11 9528.6
<151> 2001-08-14

<150> US 60/315,955
<151> 2001-08-31

<160> 14

<170> PatentIn version 3.1

<210> 1
<211> 180
<212> DNA
<213> Homo sapiens

<400> 1
acctttcatt caggaaaaat gtacttagac cctacaatgt actagtaggc ctctgcgctg 60
gcaatacaga taagataatg tagcccctgg cctcaaagga actctcctcc ttaggttgca 120
tttgtataat gtttgatfff tagattgttc tttgagccct gcattccacg aggataggtc 180

<210> 2
<211> 180
<212> DNA
<213> Homo sapiens

<400> 2
taagaacatt ttacactctt cagtataaag aagtcagaat accctaccc tatcagtaaa 60
ggcctataag ttaccattaa aaagatgtcc ttaaaaaagc cattctcagc tgggcgcggt 120
ggctcacacc tttgtcccag tactttggga agccgaggtg ggtggatcac ctgaggtcag 180

<210> 3
<211> 3213
<212> DNA
<213> Homo sapiens

<400> 3

atcagagtca ctttgatatg atgagagcag agataaacag atttgttgca tgtttttaat 60
ctttggtatg ggacatacta gaattcactg caaatacatt tttatgtaac tgttgaatgc 120
tcatacgacc atggaattct tccctttaaa gagcttggtg agcatttgag tgtagttggt 180
agacggagac gatcacgtca tagtttatag agtgcataaa gacgtaagtt accatttaat 240
acctttcatt caggaaaaat gtacttagac cctacaatgt actagtaggc ctctgcgctg 300
gcaatacaga taagataatg tagtccctgg cctcaaagga actctcctcc ttaggttgca 360
tttgataat gtttgatgtt tagattgttc tttgagccct gcattccacg aggataggtc 420
agtgggtatt aacgaggtaa aaggggagta gtacgaaagg gcattcaagc gtcccatctt 480
cgcttcaacc aaagcagccc tgcgttttcc tagttttatt aataggtttg atgtaaggtc 540
gtctttgaaa aggggggttg gctttttttt acagtgtgac tgagggtataa tttataaaaa 600
gggaaatgta tggcatggtg agttttttca catacatcct tgtgaatacc cagctcaaga 660
tccaaaacat ttccataatt tcagaaagtt ccaaaccctt gcctcttttc agtcttagcc 720
ctcttcccct gaagtaacca ctgttccgac ttcaatcact acttttatcc cacagggtta 780
ttttttggct tttttccact aaattttcaa attctttgat atggtacttt actattgacg 840
aagtactttc aactaggtt atttaatatt ctttgattca occaatatth agggacacc 900
tgtaggggac aaaaaatgaa tgagagcccc tgccttccat tgctgctaata ctggtgggaa 960
cgagacatgt atttaattaa gcatgtaaaa aatagagtgg gtgatgaaat aatctatata 1020
ctaaatcccc atgacacaca gtttacctat gtaacaaacc tgcagtgtgta cccccgaacc 1080
taaaatataa gttggaatt aaaaaaaaaac gagagggaga atagagcacc acaaccagag 1140
tgctgagatg aattacttta ttaccaaaaga aggaggagga ctcaaggagg tgccgacgtt 1200
taaaccagct cactgaaggg tgtgcagaat ttgatagggc aagataccct gggacaaggt 1260
cattctaaaa ccatgctaac atttgtactt tttttttcat tgtgatagtt cctgaaatga 1320
gttgcataaa actggtacat gtcttagggc agtctctaata tgatttttat tttgttctat 1380
ttttaaaaat tagtcttcaa atagcagatt cacatgatat taaaatataat gcacataaat 1440
tatatacaca aatataatth ctgaatgaaa tttagtatct gcatatath aagagctatt 1500
tctgtctcat atgttcataa tcttcatcca ttaaaaaaac ttttgttagg cttttctcac 1560
tctaagatta taaaaaattc tcccattatt tacctagcta gttttctagt tgttccaaaa 1620
ccatttattg aacaatccat ctttttgaca ctggtttggc atgccttaat tatatattct 1680
tgtgtgtgtt aggatctcct tttggacttt ccattctgtt cattgagtct tatcagctcc 1740
tcttacattg gtacatgat gttttaatct atggggcttt gtagtttaa tgtagggcta 1800

gttccagcgc attgttctct atcagctggt aggaacttag aatcagctt gctctgtttt 1860
 aaagaaaaac ctggatatttt tttatcagta taacattcta tttatattaa cttgaagaat 1920
 tgaaaacatc tatgatatttt cctattcagt aacgtatcac ttagaatagg ttaggttgta 1980
 ctactataaa atctcagctg cataaaacaa tttttttttg cttgtgctac acatccatta 2040
 ggtcatcaag ggactcacct tgtcaagtta ctcagagatt caggctgata taaaggtttg 2100
 atcttgacat acgctttcat gatgacagaa agcaggaag agaaggtggt gagccatgtg 2160
 ctttctcccc cttctatcca gaaatgacac atactcacat ttcattcgcc agagaaatta 2220
 acatggcccc tctaagttc aaatggatag agaaatgcct tcctaccagg tgcccagaat 2280
 tagaagagca aacattttgtg aacagttctg agtaccacaa ataccgttat ctttccactt 2340
 aagtcttctg tttcactcag tagtgcttta aacttttctt catatgtttt tcagtgtttc 2400
 ttgttgaatt tcttgatatt ttatcatggt tgttcgtact gggagtagcc tttttttcca 2460
 tttcattttc tggctggttt cattgctgggt tgtttttttg ttttgttttg tttttgagat 2520
 ggagtctcac tctgtcgccc aggctggagt gcagtgtcac aatctcggct cactgcaacc 2580
 tctgcctccc aggttcaagc gattcttctt tctcagcctc ctgagtagct gggattacag 2640
 gcatgtgcca ccatgcccag ctaatttttt atattttttag tagagatggg gtttctccat 2700
 gttggtcagg ctggtotcaa actcccaatc tcaggtgatc cgctgcctc tgccttccaa 2760
 agtgctggga ttatagacat gagccaccgt gcctggccta gttcttatgg gatgtatatg 2820
 tctttggatt catatgatat gtatatatgt ttatatattt acaagtacat acctaggagt 2880
 ggaattgttg ggtcataggt taatgcatgt ttttctgcca aacagttgtg tcaatttctg 2940
 ttttcaccgc tgtgaatgag agttgttcta ccttcttgac aacacttgat attgtcagtc 3000
 attttagcca ttctggtgaa tttatagtgc tatttctgtg tgtgtaagag agagaatgag 3060
 agaggggtgtt tgtgagaaaa ccaaagcaac actgtgagag tgtgtgtgtt tgtgagaaaa 3120
 ccaaaataca tactactgtg atttcattgg gagaaaatct gtttggata tcaaaaaaag 3180
 tagcttaatt acttcatcat tattggttta ggt 3213

<210> 4

<211> 1296

<212> DNA

<213> Homo sapiens

<400> 4

taagaacatt ttacactctt cagtataaag aagtcagaat acccctacc tatcagtaaa 60

ggcctataag ttaccattaa aaagatgtcc ttaaaaacag cattctcagc tgggcacggt 120

tttgtataat gtttgatfff tagattgttc tttgagccct gcattccacg aggataggtc 420
agtggggtatt aacgaggtaa aaggggagta gtacgaaagg gcattcaagc gtcccatcct 480
cgcttcaacc aaagcagccc tgcgttttcc tagttttatt aataggtttg atgtaaggtc 540
gtctttgaaa aggggggttg gctttttttt acagtgtgac tgagggtataa tttataaaaa 600
gggaaatgta tggcatggtg agttttttca catacatcct tgtgaatacc cagctcaaga 660
tccaaaacat ttccataatt tcagaaagtt ccaaaccctt gcctcttttc agtcttagcc 720
ctcttccctt gaagtaacca ctgttccgac ttcaatcact acttttatcc cacaggttaa 780
ttttttggct tttttccact aaatfffcaa attctttgat atggactttt actattgacg 840
aagtactttc aactagggtt atttaatat ctttgattca cccaatattt agggaacacc 900
tgtaggggac aaaaaatgaa tgagagcccc tgccttccat tgctgctaata ctggtgggaa 960
cgagacatgt atttaattaa gcatgtaaaa aatagagtgg gtgatgaaat aatctatata 1020
ctaaatcccc atgacacaca gtttacctat gtaacaaacc tgcattgtgta cccccgaacc 1080
taaaatataa gtttgaaatt aaaaaaaaaac gagagggaga atagagcatt acaaccagag 1140
tgctgagatg aattacttta ttaccaaga aggaggagga ctcaggaggg tgccgacggt 1200
taaaccagct cactgaaggg tgtgcagaat ttgataggc aagataccct gggacaagg 1260
cattctaaaa catgctaac atttgtactt tttttttcat tgtgatagtt cctgaaatga 1320
gttgcataaa actggtacat gtcttagggc agtctctaata tgatttttat tttgttctat 1380
ttttaaaaat tagtcttcaa atagcagatt cacatgatat taaaatataat gcacataaat 1440
tatatacaca aatatatttt ctgaatgaaa ttttagtatct gcataatatt aagagctatt 1500
tctgtctcat atgttcataa tcttcatcca ttaaaaaaac ttttgttagg cctttctcac 1560
tctaagatta taaaaaattc tcccattatt tacctagcta gttttctagt tgttccaaaa 1620
ccatttattg aacaatccat ctttttgaca ctggtttggc atgccttaat tatatattct 1680
tgtgtgtggt aggatctcct tttggacttt ccattctggt cattgagtct tatcagctcc 1740
tcttacattg gtacatgat gttttaatct atggggcttt gtagtttaaa tgtagggcta 1800
gttccagcgc attgttctct atcagctggt aggaacttag aatcagctt gctctgtttt 1860
aaagaaaaac ctggtatfff tttatcagta taacattcta tttatattaa cttgaagaat 1920
tgaaaacatc tatgattfff cctattcagt aacgtatcac ttagaatagg ttaggttgta 1980
ctactataaa atctcagctg cataaaaca tttttttttg cttgtgctac acatccatta 2040
ggatcatcaag ggactcacct tgtcaagtta ctcagagatt caggctgata taaaggtttg 2100

atcttgacat acgctttcat gatgacagaa agcagggag agaaggtggt gagccatgtg 2160
ctttctcccc cttctatcca gaaatgacac atactcacat ttcattogcc agagaaatta 2220
acatggcccc tcctaagttc aaatggatag agaaatgcct tcctaccagg tgcccagaat 2280
tagaagagca aacattttgtg aacagttctg agtaccacaa ataccgttat ctttccactt 2340
aagtcttctg tttcactcag tagtgcttta aacttttctt catatgtttt tcagtgtttc 2400
ttgttgaatt tcttgatatt ttatcatggt tgttcgtact gggagtagcc tttttttcca 2460
tttcattttc tggctggttt cattgctggt tgtttttttg ttttggtttg tttttgagat 2520
ggagtctcac tctgtcggcc aggctggagt gcagtgcac aatctcggct cactgcaacc 2580
tctgcctccc aggttcaagc gattcttctt tctcagctc ctgagtagct gggattacag 2640
gcatgtgcca ccatgcccag ctaatttttt atatttttag tagagatggg gtttctccat 2700
gttggtcagg ctggtctcaa actcccaatc tcaggtgatc cgctgcctc tgccttccaa 2760
agtgtgga ttatagacat gagccaccgt gcctggccta gttcttatgg gatgtatatg 2820
tctttggatt catatgatat gtatatatgt ttatatttct acaagtacat acctaggagt 2880
ggaattgttg ggtcataggt taatgcatgt ttttctgcca aacagttgtg tcaatttctg 2940
ttttcaccgc tgtgaatgag agttgttcta ccttcttgac aacacttgat attgtcagtc 3000
atthtagcca ttctggtgaa tttatagtgc tatttctgtg tgtgtaagag agagaatgag 3060
agaggggtgtt tgtgagaaaa ccaaagcaac actgtgagag tgtgtgtgtt tgtgagaaaa 3120
ccaaaataca tactactgtg atttcattgg gagaaaatct gtttgtata tcaaaaaaag 3180
tagcttaatt acttcatcat tattggttta ggt 3213

<210> 6

<211> 1296 .

<212> DNA

<213> Homo sapiens

<400> 6

taagaacatt ttacactctt cagtataaag aagtcagaat acccctacc tatcagtaaa 60
ggcctataag ttaccattaa aaagatgtcc ttaaaaacag cattctcagc tgggcgcggt 120
ggctcacacc tttgtcccag tactttggga agccgaggtg ggtggatcac ctgaggtcag 180
gagttcgaga ccagcctggc caacatggcg aaaaccatt ttcttacta aaaatacaaa 240
aattagccgg gcatgggtggc ggggtgcttgt ggtcccagct actcaagagg ctgaggtggg 300
aggatcactg agcccaggag gtggaggctg cattgagcca agattgtgcc actgcactcc 360
agcctgggtg acagagcgag actctgtctc aaaaaacca aaacaaaaa aaccagcat 420

tcttttagtaa ataattcata gttttcttca tctagaattht aaaattgtga tagttgatca	480
gcatgtcctg agcacgtgtg tttgctgtta ctagtthttaga tccggtagatg tgtatataag	540
ttataggtat aaaatcaatc ctgagttgac acaaggthttt gatgttgagt acaagtacag	600
taagtgtata ttttttagtta tgctcttagt ttttaagtcaa ttgtgtgggtt ctttctagct	660
ttaggatctg ttgaattatc ttccttagaa aagggtggtta agaatcttca cttacctatc	720
ttctacttgt ttggagaata gaagagtccc tgtggtagca gactthtgtga gtttacttgt	780
aattthtccat ctgaaagact gttcttgtht ttcgtgatga agtcttgctc tgtcgtcccag	840
gctggagtgc agtggtgcaa ccttggctca ctgcaacctc tgcctcccgg gttcaagcaa	900
ttctcctgcc tcagcctccc gagtatctgg gattacaggt gcacaccacc acacctggct	960
aattthtgtta ttttcagtag agacgggggtt tcaccatggt ggccaggctg gtctcgaact	1020
cttgacctca tgatcagccc acctcagcct tccaaagtgc tgggattaca ggtgtgagcc	1080
cccacactcg gccgttgtht tttthtaaga gacaggtct cactctgtca cctaacctgg	1140
agtacagtgg caatcatggc tcaactgtaac ctcaaatgcc cggccttagt gaagcgttct	1200
tctgccttg gcctcccaaa gtgctgggat tacaagtgtg agccatgcat ccagcttgaa	1260
agacagcttc ttaggcttga tttgthtgggt tacagg	1296

<210> 7
 <211> 24
 <212> DNA
 <213> Artificial sequence

<220>
 <223> Primer

<400> 7
 taggtcagtg ggtattaacg aggt 24

<210> 8
 <211> 23
 <212> DNA
 <213> artificial sequence

<220>
 <223> Primer

<400> 8
 gtcactthtga tatgatgaga gca 23

<210> 9
 <211> 23
 <212> DNA
 <213> artificial sequence

<220>
<223> Primer

<400> 9
cctcgttaat acccactgac cta 23

<210> 10
<211> 24
<212> DNA
<213> artificial sequence

<220>
<223> Primer

<400> 10
ggcaatacag ataagataat gtag 24

<210> 11
<211> 21
<212> DNA
<213> artificial sequence

<220>
<223> Primer

<400> 11
ttgatcagca tgtcctgagc a 21

<210> 12
<211> 22
<212> DNA
<213> artificial sequence

<220>
<223> Primer

<400> 12
ctaccctatc agtaaaggcc ta 22

<210> 13
<211> 21
<212> DNA
<213> artificial sequence

<220>
<223> Primer

<400> 13
tgctcaggac atgctgatca a 21

<210> 14
<211> 23
<212> DNA

<213> artificial sequence

<220>

<223> Primer

<400> 14

aaaaacagca ttctcagctg ggc

23