

J. A. STEWART.
RAILROAD TIE.
APPLICATION FILED MAR. 22, 1911.

998,425.

Patented July 18, 1911.

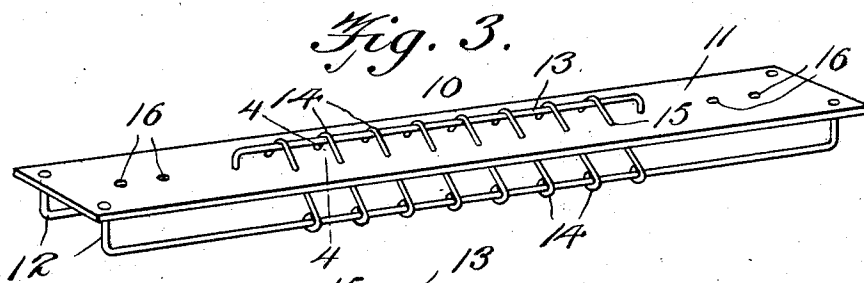
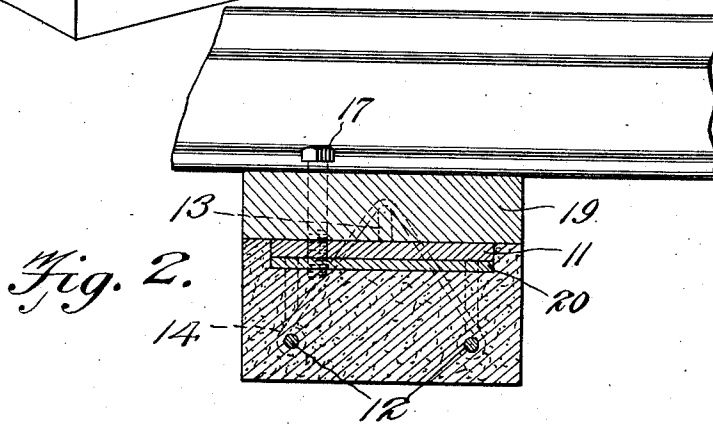
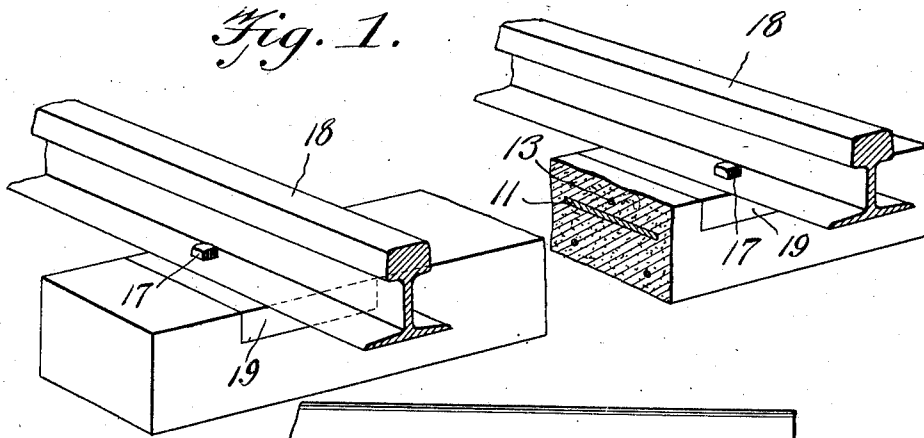
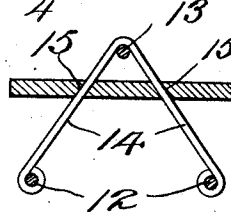

Fig. 4.



Witnesses

Frank B. Hoffman
P. A. Hoiter

Inventor
John A. Stewart

By *Victor J. Evans*
Attorney

UNITED STATES PATENT OFFICE.

JOHN A. STEWART, OF DENVER, COLORADO.

RAILROAD-TIE.

998,425.

Specification of Letters Patent. Patented July 18, 1911.

Application filed March 22, 1911. Serial No. 616,122.

To all whom it may concern:

Be it known that I, JOHN A. STEWART, a citizen of the United States, residing at Denver, in the county of Denver and State of Colorado, have invented new and useful Improvements in Railroad-Ties, of which the following is a specification.

The invention relates to railroad ties and has for an object to provide a reinforced concrete railroad tie adapted to constitute a base for rails.

Among other features my invention embodies a skeleton frame consisting of a plate, a plurality of rods connected with the said plate and wires connecting the said rods and passing through the said plate, the said skeleton frame being adapted to be inclosed by concrete, thus producing a substantially rectangularly shaped railroad tie.

Reference is to be had to the accompanying drawings constituting a part of this specification, in which similar characters of reference denote corresponding parts throughout the views, and in which—

Figure 1 is a perspective view disclosing one of my railroad ties with rails mounted thereon, parts being broken away to disclose the underlying structure. Fig. 2 is a transverse sectional view of my tie, the said view being taken immediately adjacent one of the rails shown in Fig. 1. Fig. 3 is a perspective view of the skeleton frame of my railroad tie. Fig. 4 is a sectional view taken on the line 4—4 in Fig. 3.

Referring more particularly to the various views I employ a skeleton frame 10 consisting of a plate 11 having rods 12 and 13 extending longitudinally thereof and connected thereto, the said rods 12 being connected to the plate 11 on the under side of the same and the rod 13 being connected to the plate on the upper side of the same. Wires 14 having their ends connected to the rods 12 are adapted to pass through apertures 15 in the plate and pass over the rod 13 as shown in Fig. 3, thus securely binding the rods 12 relatively to the plate 11 and the rod 13. Suitable bolt holes 16 are provided in the plate 11 and are adapted to receive the ends of bolts 17 passing through rails 18, the said bolts being also adapted to pass through a cushioned block 19 disposed to fit in the cut out portion of my tie and the said bolts 17 pass through metal plates 20 disposed adjacent the under side of the plate 11 as will be seen in Fig. 2. The skeleton

frame 10 is covered with concrete and substantially inclosed therein as shown in Figs. 1 and 2 and it will be understood that the plate 11 can be either provided with a plain surface or with corrugated surfaces to enable the concrete to more easily adhere to the plate.

Having thus fully described the invention, what I claim as new, is:—

1. A railroad tie comprising a reinforcing plate, a rod connected to the said plate and extended from the upper side thereof, a plurality of rods connected to the said plate and extended from the under side thereof, flexible reinforcing means connecting the said rods on the under side of the plate to the said rod on the upper side of the plate, said plate and said rods being adapted to be inclosed in concrete and bolts adapted to pass through the said plate to substantially secure the said rails thereto.

2. A railroad tie comprising a skeleton frame, consisting of a plate, rods connected to the plate and extended from the upper and under sides of the same and flexible reinforcing means connecting the said rods and adapted to pass through apertures in the said plate, said skeleton frame being adapted to be inclosed in concrete.

3. In a railroad tie the combination of a skeleton frame consisting of a reinforcing plate, rods connected to the said plate and extending from the upper and under sides thereof, flexible reinforcing means connecting the said rods and passing through apertures in the said plate, the said skeleton frame being adapted to be inclosed in concrete, metal blocks disposed beneath the said plate, wooden blocks disposed to rest on the said plate and bolts for connecting rails to the said skeleton frame, the said bolts being adapted to pass through the said wooden blocks, the said plate and the said metal blocks beneath the said plate.

4. In a railroad tie, the combination of a skeleton frame having a reinforcing plate, rods connected to the said plate and extending from the upper and under sides thereof, flexible reinforcing means connecting the said rods and passing through apertures in the said plate, the said skeleton frame being adapted to be inclosed in concrete, cushion blocks disposed in depressions formed in the tie at the ends thereof and above the said plate, and bolts for connecting rails, disposed on the said cushion blocks to the said

skeleton frame and to the said cushion blocks.

5 5. A railroad tie comprising a skeleton frame having a plate, rods connected to the plate and extending from the upper and under sides of the same, flexible reinforcing means connecting the said rods and adapted to pass through apertures in the said plate, said skeleton frame being adapted to be in-
10 closed in concrete, and cushion blocks

mounted in depressions formed in the concrete and adapted to constitute cushions for rails.

In testimony whereof I affix my signature in presence of two witnesses.

JOHN A. STEWART.

Witnesses:

ROBERT A. STEWART,
GEORGE S. BARKER.

Copies of this patent may be obtained for five cents each, by addressing the "Commissioner of Patents, Washington, D. C."
