

(19) **DANMARK**

(10) **DK/EP 3247620 T3**



(12) **Oversættelse af
europæisk patentskrift**

Patent- og
Varemærkestyrelsen

-
- (51) Int.Cl.: **B 63 B 1/06 (2006.01)** **B 63 B 1/40 (2006.01)** **B 63 B 9/02 (2006.01)**
- (45) Oversættelsen bekendtgjort den: **2019-07-15**
- (80) Dato for Den Europæiske Patentmyndigheds bekendtgørelse om meddelelse af patentet: **2019-05-15**
- (86) Europæisk ansøgning nr.: **15817835.0**
- (86) Europæisk indleveringsdag: **2015-12-21**
- (87) Den europæiske ansøgnings publiceringsdag: **2017-11-29**
- (86) International ansøgning nr.: **EP2015080842**
- (87) Internationalt publikationsnr.: **WO2016102497**
- (30) Prioritet: **2014-12-22 EP 14199833**
- (84) Designerede stater: **AL AT BE BG CH CY CZ DE DK EE ES FI FR GB GR HR HU IE IS IT LI LT LU LV MC MK MT NL NO PL PT RO RS SE SI SK SM TR**
- (73) Patenthaver: **Rasmussen Maritime Design AS, P.O. Box 37, 4661 Kristiansand, Norge**
- (72) Opfinder: **MOEN, Roar, Johan, Mjølemoen - Grødum, N-4658 Tveit, Norge**
- (74) Fuldmægtig i Danmark: **NORDIC PATENT SERVICE A/S, Bredgade 30, 1260 København K, Danmark**
- (54) Benævnelse: **DESIGN AF FORRESTE DEL AF ET FARTØJ**
- (56) Fremdragne publikationer:
WO-A1-2013/011332
WO-A1-2014/091259
JP-A- S6 042 187
US-A- 4 003 325

DESCRIPTION

TECHNICAL FIELD OF THE INVENTION

[0001] The present invention relates to the design of seagoing vessels and can be applied to the majority of hull types, from slow-moving ships, rigs and barges to high-speed ships and boats that are operated up to planing speed, and also to sailing boats and multi hull vessels. In particular, the invention relates to the configuration of the vessel's forepart comprising a device that reduces the wave resistance of the vessel, as well as reducing or eliminating spray and wave-breaking resistance.

BACKGROUND OF THE INVENTION

[0002] When a vessel moves at the surface of a water mass, a number of different resistance factors act against the vessel's movement. The resistance coefficients for the individual components for a displacement vessel are illustrated in Figure 1. As can be seen, the frictional resistance C_F and the wave resistance C_W are the two major factors. For a given vessel, Froude's number $[F_N]$ increases with increasing speed, indicated along the x-axis:

$$F_N = \frac{\text{speed} \left[\frac{m}{s} \right]}{\sqrt{9.81 \left[\frac{m}{s^2} \right] \times \text{Length of vessel} [m]}} \quad (1)$$

[0003] The resistance coefficients C_F and C_W are multiplied by the square of the speed (v^2) to obtain the resistance to forward movement in Newtons [N]. Consequently, the wave resistance increases very rapidly with increasing speed.

[0004] Most vessels have a bow configuration where the water masses the vessel meets when at speed are essentially displaced laterally in the transverse direction of the vessel. As the vessel moves through the water masses, a local deceleration of the water is produced ahead of the bow, i.e., a reduction of relative water velocity relative to the hull. Further back, where the width of the hull increases, a relative acceleration of the water masses occurs, as the water is forced out to the sides, and possibly under the vessel, as a consequence of the shape of the hull. These relative changes in water velocity are the origin of wave formation and change in pressure, and are given by Bernoulli's equation:

$$\frac{1}{2} \rho v^2 + \rho gh + p = \text{constant} \quad (2)$$

[0005] Lower relative water velocity leads to an increase in pressure and a wave crest in relation to the surrounding water masses, whilst higher relative water velocity gives lower pressure and a wave trough.

[0006] A vessel thus forms a wave crest ahead of the vessel, where the relative water velocity is low. Further back, where the width of the hull increases, a wave trough is produced due to high relative water velocity.

[0007] The increased water velocity under the hull also results in lower pressure under the hull, and consequently loss of buoyancy when the vessel's speed increases. This resistance is included in the term wave resistance.

[0008] The waves generated by a hull in motion, and which spread to surrounding water masses, represent lost energy. The percentage of the total resistance to forward movement at sustained speed that wave resistance normally constitutes is, depending on vessel type, 30-70%, and increases sharply with increasing speed.

[0009] To reduce a vessel's resistance to forward movement, it is therefore crucial to minimise wave resistance.

PRIOR ART

Bulb

[0010] To reduce the total wave formation from a vessel, the vast majority of vessels of a certain size are today equipped with a bulb in some form or other. The bulb basically works by causing generation of an own wave in the surrounding water masses. It is attempted to have this wave as much as possible in antiphase to the hull's wave system, so as to obtain favourable wave interference. An illustration of wave formation from a prior art bulb, and the position of the water surface 5, is shown schematically in Figures 3A and B.

[0011] Figure 3A is a side view of a vessel with a bulb according to the prior art, where the vessel is operated at design speed. The wave system 31 generated by the vessel's bulb is in antiphase to the wave system 32 generated by the hull's bow portion, such that the resultant wave 33, which is the sum of the two wave systems 31 and 32, is virtually flat.

[0012] As the length of the wave increases with increasing speed, the problem with a bulb is therefore that the wave trough will be produced further back on the vessel when the speed increases, and further forward when the speed is reduced. The wave crests, on the other hand, will

be produced at the same point, and it is therefore only within a limited speed range that the wave from the bulb and the waves from the vessel's hull will have a favourable wave interference. At speeds other than the design speed, the waves from the bulb and the hull will no longer be in antiphase. This can be seen clearly from the schematic illustration shown in Figure 3B, where the increased wave length results in the bulb's wave system 31 no longer phasing out the wave system 32 generated by the hull's bow portion, such that the resultant wave 33 increases.

[0013] In practice, a bulb works at relatively low speeds, typically from $F_N = 0.23$ to $F_N = 0.28$. There are however vessels where the bulb is positioned far forward in front of the bow portion of the hull such that wave cancellation occurs at higher speeds. But for most vessels, it is of little expedience to place the bulb so far forward of the bow portion. For a speed of $F_N = 0.32$, the bulb must be placed about $\frac{1}{4}$ of the hull's length in front of the bow area, and for a speed of $F_N = 0.4$, the bulb must be placed about $\frac{1}{2}$ a hull length in front of the bow area.

[0014] Seen from in front, the bulb is often almost spherical. Alternatively, it can be made more triangular. Different configurations of conventional bulbs are shown schematically in Figures 4A, B and C. Broken line 5 indicates the water surface. A common feature of all bulbs is that the front area and width are small in relation to the front area and width of the hull below the water surface. Furthermore, bulbs of the prior art have a width/height ratio of about one. The position and configuration of the bulb mean that it basically displaces oncoming water masses equally in the horizontal and the vertical plane, as shown by arrows in Figures 4A, B and C.

Thin wave-making plate

[0015] There are also other known solutions based on wave cancellation between two bodies.

[0016] Reference is made to US 4,003,325, which describes a thin wave-making bottom plate based on wave cancellation between the wave-making plate and the hull.

[0017] US 4,003,325 discloses that the wave-making plate has a maximum width of about $\frac{1}{3}$ the hull width and that the vertical thickness of the plate under light loading conditions may occupy as much as $\frac{1}{3}$ of the vessel's draught at the bow, and further that the plate is disposed substantially coplanar with the bottom of the hull. The surface area of the thin plate seen from in front is thus very small in relation to the front area of the hull below the water surface (maximum about 11%).

[0018] It is noted that the planar/straight top surface of the thin plate body, its limited thickness, and its position substantially coplanar with the hull bottom a distance below the water surface, will only to a small degree generate a wave, and that this wave will thus only to a small degree contribute to phasing out the bow wave produced by the bow lying behind.

[0019] As described above in relation to the bulb, this solution, which is based on favourable wave interference, will also only be capable of being optimised within a narrow speed range and in practice only at relatively low speeds.

Wing profile-shaped flange

[0020] Reference is made to JPS58-43593U.

[0021] As explained above in relation to wave resistance, when a hull passes through a mass of water there will arise local deceleration i.e., reduced relative velocity, of the mass of water ahead of the bow. The lower relative velocity of the water mass leads to a pressure increase and a wave crest (bow wave).

[0022] The solution in JPS58-43593U seeks to reduce the height of the bow wave generated by the bow area in that a wing profile shaped flange is placed on the hull bow area below the water surface, the curved top surface of the wing profile resulting in increased velocity and consequently a lower pressure in the bow wave on the top surface of the wing profile shaped flange, which further results in a reduction in the height of the bow wave.

Lifting foils

[0023] Among other known resistance-reducing devices, mention may be made of submerged lifting foils that lift the hull up out of the water. At the curved top surface of the foil, the water velocity increases, thereby producing a lower pressure at the top surface of the foil than at the underside of the foil. The top surface of the foil thus generates a lift.

[0024] Figure 5A shows a mass of water flowing toward and across a foil with an initial velocity V_0 in the direction of the double lined arrow at position 1. The arrows pointing 90 degrees away from the foil's top surface indicates a typical underpressure distribution on the top surface of the foil, having a peak underpressure approximately at the maximum thickness of the foil profile at position 3. According to the Bernoulli equation (2), a foil having the underpressure distribution shown in Figure 5A, will have a velocity distribution of the water mass as illustrated in Figure 5B reaching a maximum velocity V_{MAX} approximately at the maximum thickness of the foil profile at position 3. The velocity of the water mass accordingly increases from slightly behind the leading edge of the foil at position 2 to the maximum profile thickness at position 3,

followed by decreasing water velocity from position 3, via position 4 at the rear top surface of the foil, to position 5, where the water mass again reaches its initial velocity V_0 . In order to achieve this particular pressure and velocity distribution, the foil must be arranged at a sufficient depth under the water surface.

[0025] If the foil is not sufficiently submerged, the negative pressure that is formed at the top surface of the foil will cause a wave trough in the water surface as shown in Figure 7B, where the broken line 5 indicates the water surface when the foil is not present. The foil thus produces waves, which in turn generate increased resistance. In addition to the wave formation, an insufficiently submerged foil will generate less lift.

[0026] Even in the case of sufficiently submerged foils, the lift that is generated by the foil results in a resistance which increases with increasing lift. Since the foils per se cause both frictional resistance and resistance due to lift, a reduction in total resistance will only be achieved for the hull when the hull is lifted up considerably from the water. For a hull of substantial weight, this will in itself require a great deal of energy, and thus be inexpedient. Foils will therefore primarily give lower resistance to forward movement for hulls of relatively low weight that are intended to travel at high speed.

[0027] Moreover, it is also known that submerged foils can be intended to counter the vessel's motions.

[0028] Furthermore, there are also known submerged foils of some fullness, which in addition to dynamic lift (lift due to underpressure on the top surface of the foil) are intended to give displacement buoyancy (buoyancy resulting from the volume of the foil). Here, reference is made to US 7,191,725 B2.

Wing board

[0029] Reference is made to JP 1-314686 which describes a guiding wing board mounted near a lower tip of a bow. The guiding wing board is described to reduce the wave-making resistance and to suppress turbulence in the bow area.

[0030] Figure 6a of JP 1-314686 shows the pressure distribution at the top surface of the wing board and how the underpressure above the wing board lowers the water surface above and behind the wing board when acting alone, c.f. also Figure 7B in this document. The object of the wing board is to prevent the water surface in front of the bow area of a vessel from swelling up, i.e. not making a wave crest or a wave trough at the location of the bow area. This is achieved by arranging the wing board at a lower tip of a bow, thereby generating a strong negative pressure region at the back surface of the wing board.

[0031] Furthermore, the object of the wing board is to act as a guiding wing board as shown in figure 5b of JP 1-314686 (marked with reference numeral 8). As can be seen from figure 5a of JP 1-314686, when a wind is blown into a curved wind tunnel 11 generating a large change in flow direction, a flow is separated. However, the separation of the flow is reduced or prevented due to the effect of the guiding wing board 8 shown in figure 5b of JP 1-314686. The total flow resistance therefore decreases. The effect of wing board according to JP 1-314686 is claimed to be exactly the same as guiding wing board in a wind tunnel.

[0032] It is noted that all the wing boards mounted to a vessel as drawn in JP1-314686 will create substantial vortex turbulence, known as "tip vortex" in the field of aviation. A vortex arises due to pressure differences at the top surface and underside of a foil (or an airplane wing). The pressure at the underside of the foil tries to equalize the underpressure at the top surface of the foil. Such a vortex is illustrated with curved arrows in Figure 8A, B and C (foil seen from above, from the side and from in front, respectively). The increased drag due to such a vortex can be significant and is increasing with the pressure difference between the top and bottom surface of a foil. The velocity vector of the water particles effected by the vortex is rotating around an axis about 90 degrees on the direction of travel of the vessels at the wing board's trailing edge, and is unfavorable for the total resistance of the vessel.

[0033] Consequently, the wing board according to JP1-314686 will not contribute to decreasing the resistance of the entire flow.

Vortex inducing wing

[0034] Patent publication JP S60 42187A discloses a wing arrangement in front of the vessel's bow that seeks to reduce wave breaking resistance by deliberate generation of wing end vortexes opposing wave breaking vortexes generated by the bow of vessel.

[0035] As a vessel travels forward, the pressure of water surrounding a bow increases, generating a bow wave. If the crest of this bow wave collapses forward it will create a wave breaking vortex. In the solutions disclosed in patent publication JP S60 42187A, this induced wave breaking vortex at the bow is cancelled by a wing end vortex with opposite direction of rotation generated in the water by a wing arranged near the waterline. Further, the wing suppresses a raise of water surface ahead of the bow so that the occurrence of a bow wave breaking is reduced. The result claimed, is a significant reduction in wave breaking resistance.

[0036] For the generation of wing end vortex reference is made to Figures 8A, B and C, and former description in this document.

[0037] JP S60 42187A describes a fourth embodiment (cf. figure 14 and 15 of JP S60 42187A) with the same effect as already described above, except for how the bow wave is suppressed. In the fourth embodiment, the wing body is arranged such that water flowing towards the wing changes direction, and thus creates a wave in anti-phase with the bow wave of the ship. The resulting wave is claimed to have

considerably reduced height. In addition, also this wing is designed to create a vortex in antiphase with the wave breaking vortex created by the vessel.

[0038] Hence, the purpose of the wing is to reduce the wave breaking resistance from the bow area of a vessel.

[0039] It is apparent from Figure 1 that the wave breaking resistance $[C_{WB}]$ constitutes a minor part of the wave resistance $[C_W]$ of a vessel. The wave pattern resistance $[C_{WP}]$ is by far the main contributor to wave resistance $[C_W]$.

GENERAL DESCRIPTION OF THE INVENTION

[0040] The object of the present invention is to develop a forepart that reduces the vessel's resistance to forward movement over a wide speed range. Furthermore, the present invention can improve the vessel's seagoing properties, and also allow design of vessels of greater width and shorter length compared with conventional vessels. The objects described above are achieved with a vessel according to patent claim 1. Further advantageous features are defined in the dependent patent claims.

[0041] In particular, the invention comprises a vessel comprising a hull with a bow area, defined as the area of the hull seen from in front below a water surface when the vessel is lying motionless and is floating in a mass of water, and one (or more) body(ies) arranged in proximity to the bow area, for example upstream of the bow area. Note that the expression "is lying motionless" should not be interpreted strictly, but to include small movements from, for example, environmental forces such as currents, wind, etc. The body comprises one (or more) leading edge(s), one (or more) trailing edge(s) lying downstream of the leading edge(s), one (or more) underside(s) and one (or more) top surface(s). The top surface of the body comprises one (or more) forward top surface(s) that extend from the leading edge of the body to one (or more) outer contour line(s) of the body seen from in front. The contour line can, as an additional criterion, be found by drawing a line through the points of intersection where the tangents of the top surface in the vessel's direction of travel are horizontal. The highest point of the body, seen from in front, is located higher than half of the vessel's deepest draught when the vessel, without payload and without ballast, is lying motionless and is floating in a mass of water. Note that the expression 'highest point of the body' can also cover the cases where there are several highest points on the top surface and/or one or more highest flat portions. The vessel's deepest draught without payload and without ballast should be measured when the vessel's own fuel tanks and lubricating oil tanks are empty. The deepest draught is defined by the minimum depth of water a vessel can navigate without grounding. Preferably the highest point of the body, seen from in front, is located higher than half of the vessel's deepest draught in at least one of the vessel's loading conditions. More preferably, the highest point of the body, seen from in front, is located higher than 2/3 of the vessel's deepest draught measured in at least one loading condition, more favourable higher than 5/6 of the vessel's deepest draught in at least one loading condition, even more favourable higher than 8/9 of the vessel's deepest draught in at least one loading condition, for example at or near an undisturbed water line.

[0042] The vertical section of the body in the vessel's direction of travel and the extent of the body in the transverse direction of the hull is, in at least one of the vessel's load conditions, further designed to displace an oncoming water mass over the top surface of the body at a speed of the vessel that is equal to or greater than a lower design speed defined as the lowest speed of the vessel at which the oncoming water mass that is primarily displaced in a vertical plane along the vessel's direction of travel obtains an essentially laminar flow over the forward top surface of the body, preferably the whole of the forward top surface of the body, more preferably over the whole top surface of body, and where the configuration of the top surface of the body accelerates the oncoming water mass that is lowered in or by the gravitational field downstream of the contour line, such that the oncoming water mass obtains a velocity and a direction at the trailing edge of the body that leads the mass of water away from the bow area, or essentially parallel to the bow area, or a combination thereof. Thus, the bow area itself will to the least possible extent displace the oncoming water mass, which results in reduced or no wave resistance from the bow area, and reduced wave resistance for the vessel. By reduced wave resistance here is meant reduced compared with the wave resistance from vessels with conventional bow design. Note that the terms downstream/upstream throughout this document refer to the flow line of the water mass in the position in question.

[0043] In an advantageous embodiment, the top surface of the body is further configured such that the oncoming water mass obtains a direction downstream of the contour line that leads the oncoming mass of water away from the bow area, or essentially parallel to the bow area, or a combination thereof. Note that the expression 'essentially parallel to the bow area' means that the whole of the water mass that is on the top surface of the body, in the event of displacement of the bow area, is displaced at an angle of attack of less than 25 degrees relative to the flow line the water mass would have had if the bow area had been removed, more advantageously at an angle of attack of less than 15 degrees, even more advantageously at an angle of attack of less than 10 degrees for example exactly parallel.

[0044] In another advantageous embodiment, said acceleration comprises a lifting of the oncoming water mass in the gravitational field upstream of the contour line.

[0045] In another advantageous embodiment, the leading edge of the body extends out to the largest width of the body, seen from above.

[0046] In another advantageous embodiment, the leading edge of the body is located upstream of the bow area.

[0047] In another advantageous embodiment, the body is arranged such that the leading edge of the body is below or at the water surface in at least one of the vessel's load conditions when the vessel is lying motionless and is floating in a mass of water. The word 'at' here should not be interpreted strictly but to allow the leading edge to project slightly above the water surface.

[0048] In another advantageous embodiment, the body is positioned such that the body's highest point, seen from in front, is located higher

than 3/4 of the vessel's deepest draught reckoned from the vessel's lowest point when the vessel, without payload and without ballast, is lying motionless and is floating in a mass of water. For example, the highest point of the body is located at or higher than the water surface. Note that the deepest draught of the vessel can be determined by the vessel's rudder, propeller, the body or another part of the vessel.

[0049] In another advantageous embodiment, the contour line of the body and its leading edge, in at least one of the vessel's load conditions, is positioned such that more than 20% of the oncoming water mass is lifted above the water surface at a speed of the vessel that is equal to or greater than the lower design speed.

[0050] In another advantageous embodiment, the trailing edge of the body, seen in one vertical section, is pointed or almost pointed, or has any other shape that results in a marked boundary between the top surface and underside of the body. The term 'pointed' should here not be interpreted strictly but also to allow a somewhat blunt or rounded shape. Another definition of 'pointed' may also be that the trailing edge of the body is shaped such that no turbulence or least possible turbulence is generated in the area where the water masses leave the body. Another definition of 'pointed' may be that the trailing edge of the body has, in a vertical section, a maximum thickness that is less than 5% of the body's maximum thickness, for example, less than 3%. Alternatively, the trailing edge of the body, seen in one vertical section, may have a shape identical to, or almost identical to, the trailing edge of a hydrofoil, for example like the trailing edge of one or more hydrofoils illustrated in patent publication US 6,467,422B1 or GB 992375A or JPH0656067A or US 4,335,671A. All these patent publications are included by reference.

[0051] In another advantageous embodiment, the vertical section of the body in the vessel's direction of travel and the extent of the body in the transverse direction of the hull, in at least one of the vessel's load conditions, are configured such that more than 20% of the oncoming water mass that passes over the top surface of the body at a speed of the vessel that is equal to or greater than the lower design speed is led under the hull, more advantageously more than 30%, even more advantageously more than 40%, even more advantageously more than 50%, even more advantageously more than 60%, even more advantageously more than 70%, even more advantageously more than 80%, even more advantageously more than 90%, for example 100%. The expression 'under the hull' means below the hull between two vertical plane in the vessel's direction of travel and spaced apart at a distance corresponding to the maximum width of the bow area at the water surface when the vessel is seen from in front. An example of a vertical section configuration in the direction of travel of the vessel is to adjust the position of the body's trailing edge until a desired velocity vector is obtained. This can be achieved by altering the angle of attach of the body.

[0052] In another advantageous embodiment, the body is arranged at a distance from the bow area, such that at least one passage is formed between the body and the bow area.

[0053] In another advantageous embodiment, the trailing edge of the body is arranged at a distance from the bow area such that the hull, in at least one of the vessel's load conditions, prevents the part of the oncoming water mass that is led under the hull from rising when the vessel's speed is equal to or greater than the lower design speed. Note here that the distance of the trailing edge from the bow area can be either in the horizontal plane or in the vertical plane or a combination thereof. Note further that the expression 'prevents the oncoming water mass from rising' is intended to mean that this mass of water is held down by the hull, so that the hull essentially prevents or reduces the formation of waves that spread to the surrounding water masses.

[0054] In another advantageous embodiment, the body's maximum transverse extent (B) divided by the body's maximum height (H), seen from in front, is greater than 1.5 but preferably less than 8.0, for example 4.0.

[0055] In another advantageous embodiment, the area of the body, seen from in front, constitutes more than 20% of the bow area at the vessel's maximum draught, more advantageously more than 30%, even more advantageously between 40 and 100%, for example 50%. The area of the body, seen from in front, can be calculated either i) as the maximum cross sectional area of the body or preferably ii) also take into account the trim of the body.

[0056] In another advantageous embodiment, the vertical section of the body in the vessel's direction of travel has a maximum extent in the vertical plane that constitutes at least 40% of the hull's draught when the vessel is neutrally trimmed and loaded with 10% of its maximum payload, more advantageously at least 50% of the hull's draught, even more advantageously at least 60 %, even more advantageously at least 70 %, for example 75% of the hull's draught. By maximum extent in the vertical plane is meant the body's highest point minus its lowest point along a vertical section in the vessel's direction of travel.

[0057] In another advantageous embodiment, the body has a maximum transverse extent, seen from in front, that is at least 3/8 of the hull's maximum width, seen from in front, more advantageously at least 5/8 of the hull's maximum width, even more advantageously at least 7/8 of the hull's maximum width, for example, the whole of the hull's maximum width.

[0058] In another advantageous embodiment the top surface of the body comprises at least one convex portion that constitutes more than 10% of the top surface, more advantageously more than 20% of the top surface.

[0059] In another advantageous embodiment, the underside of the body, seen in a vertical section along the vessel's direction of travel, is straight. Alternatively, the underside of the body can be configured with at least one convex portion or at least one concave portion, or a combination thereof.

[0060] In another advantageous embodiment, the body forms an asymmetrical profile in the vessel's direction of travel.

[0061] In another advantageous embodiment, the top surface of the body downstream of the contour line has a configuration which, in at least

in one of the vessel's load conditions, at or above the lower design speed, results in the oncoming water mass that passes on the top surface of the body is lowered down to, or below, the height position of the leading edge of the body before the oncoming water mass meets the hull.

[0062] In another advantageously embodiment, the leading edge of the body has a straight shape or a curved shape, seen from above, or a combination thereof.

[0063] In another advantageous embodiment, the trailing edge of the body has a straight shape or a curved shape, seen from above, or a combination thereof.

[0064] In another advantageous embodiment, the vertical section of the body in the vessel's direction of travel and the extent of the body in the hull's transverse direction, in at least one of the vessels load conditions, is designed to lead a major portion, i.e., more than 50%, of a lifted water mass, caused by the displacement of the body, in over the forward top surface of the body at a speed of the vessel that is equal to or greater than the lower design speed. The proportion of the lifted water mass that is led in over the forward top surface of the body is thus supplied with potential energy that can be utilised downstream of the top surface contour line to give the water mass increased velocity at the trailing edge of the body. Note that by increased velocity here is meant a higher velocity than if the water mass had not been lifted above the water surface. Said proportion of lifted water mass can more advantageously constitute over 60%, even more advantageously over 70%, for example 80%.

[0065] In another advantageous embodiment, the area of the body, seen from in front, in at least one of the vessel's load conditions, constitutes more than 20% of the part of the bow area located behind the body between two vertical planes in the vessel's direction of travel and spaced apart at a distance corresponding to the maximum width of the body. More advantageously, said surface area constitutes more than 30%, even more advantageously more than 40%, even more advantageously more than 50%, even more advantageously more than 60%, even more advantageously more than 70%, even more advantageously more than 80%, for example 90%.

[0066] In another advantageous embodiment, the transverse extent of the body and its position in relation to the water surface, are selected so that, in at least one of the vessel's load conditions, a major portion, i.e., more than 50%, of the oncoming water mass that passes over the top surface of the body at a speed of the vessel that is equal to or greater than the lower design speed, is isolated from the surrounding water masses. An isolation of this kind will give as a result that the isolated water mass can be accelerated without significant pressure drop and wave formation in the surrounding water masses. Said proportion of oncoming water mass that is isolated from surrounding water masses can more advantageously constitute over 60%, even more advantageously over 70%, even more advantageously over 80%, for example 100%.

[0067] In another advantageous embodiment, the underside of the body, in at least one of the vessel's load conditions, is shaped and/or angled to provide dynamic lift at a speed of the vessel that is equal to or greater than the lower design speed, such that the body obtains unchanged, or almost unchanged, buoyancy compared with when the vessel is lying motionless and is floating in a mass of water.

[0068] In another advantageous embodiment, the vertical position of the body relative to water surface, in at least one loading condition, is such that the oncoming water mass at the body's top surface downstream the maximum thickness of the body, measured along the vessel's direction of travel and 90 degrees on the body's chord line, obtains an essentially constant or increasing velocity, at a speed of the vessel that is equal to or greater than the lower design speed.

[0069] In another advantageous embodiment, the vertical position of the body relative to water surface is such that the pressure in the oncoming water mass is essentially constant above the top surface, downstream of the outer contour line, at a speed of the vessel that is equal to or greater than the lower design speed.

[0070] In another advantageous embodiment, the body's cross sectional area, seen from in front, is decreasing in height towards the peripheries in the body's transverse direction such that the pressure built up at the body's underside and the pressure built up at the body's top surface is essentially equalized at the body's peripheries, thereby suppressing generation of vortexes.

[0071] In another advantageous embodiment, the periphery at each transverse side of the body comprises a plate extending over a major part, i.e. more than 50 %, of the body along the vessel's direction of travel, the geometrical shape of the plate being designed such that the pressure at the body's underside has no or insignificant effect on the pressure at the body's top surface, thereby suppressing generation of vortexes. The plates may alternatively follow the curvature of the body's peripheries over a major part of the body, or a combination thereof. The plates may be directed vertically, i.e. with a main component in the vertical direction. The term 'vertical' is herein defined as a direction perpendicular to the body's transverse direction after the body has been positioned at the vessel's bow area.

[0072] In another embodiment, the body is incorporated in the bow area.

[0073] In another embodiment, the body is configured with a tapering section towards the leading edge of the body and/or the trailing edge of the body when seen in the vessel's direction of travel, across at least 20% of the transverse extent of the body, preferably at least 30% of the transverse extent of the body, more preferably at least 40%, for example 100%.

[0074] In another embodiment, the body has mounted thereon at least one foil which, in at least one of the vessel's load conditions, provides dynamic lift at a speed of the vessel that is equal to or greater than the lower design speed, such that the body obtains unchanged, or almost unchanged, buoyancy compared with when the vessel is lying motionless and is floating in a mass of water.

[0075] In another embodiment, the top surface of the body, seen in a vertical section along the vessel's direction of travel, comprises at least

one convex portion and at least one concave portion.

[0076] In another embodiment, the body is configured such that, in at least one of the vessel's load conditions, at or above the lower design speed, a negative pressure resulting from water acceleration at the underside of the body is, fully or to a significant degree, neutralised at the trailing edge of the body by the oncoming water mass from the top surface of the body.

[0077] In another embodiment, the oncoming water mass which, in at least one of the vessel's load conditions, at or above the lower design speed, is led over the body's top surface, forms a supercritical flow at the trailing edge of the body.

[0078] In another embodiment, the body, at its forward part, is shaped such that it only slightly forms a pressure wave upstream of the body above the lower design speed.

[0079] In another embodiment, the body is shaped such that, in at least one of the vessel's load conditions, at or above the lower design speed, a stationary wave trough is formed at the trailing edge of the body along 20-100% of the vessel's width, more advantageously 30-100%, even more advantageously over 40%, even more advantageously over 60 %, for example 100%. In another embodiment, the lowest point of the body is located at a distance below the water surface corresponding to between 2/3 and 3/2 of the hull's deepest draught in at least one of the vessel's load conditions, for example, without payload and without ballast.

[0080] In another embodiment, the body is formed with a tapering cross-section out towards the periphery of the body in the transverse direction over at least 20% of the length of the body in the vessel's direction of travel, for example, over at least 50% of the length of the body.

[0081] An alternative definition of the lower design speed is the speed at which the flow characteristic of the oncoming water mass, on increasing speed, changes from an essentially turbulent flow to an essentially laminar flow at the forward top surface of the body; cf. Figures 20A and B, respectively.

[0082] Another alternative definition of the lower design speed is the speed at which the mean velocity of the oncoming water mass over the forward top surface of the body is not markedly lower than the vessel's speed; cf. Figure 20B. In Figure 20A said mean speed of the body's forward top surface is markedly lower.

[0083] Another alternative definition of the lower design speed is the speed at which the mean velocity of the oncoming water mass changes from markedly lower (cf. Figure 20A) to about the same (cf. Figure 20B) as the vessel's speed at the forward top surface of the body.

[0084] Another alternative definition of the lower design speed is the speed of the vessel at which the vessel's energy consumption undergoes a marked drop. Here, reference is made to the results from model tests given in the graph in Figure 2 where it is estimated that the model boat in Test B undergoes a marked drop in resistance to forward movement at the speed of about 0.99 m/s. This estimate is based on visual observations of change in the flow pattern similar to the change in flow pattern as shown in Figure 20A and B, and that this change in Test B occurred just below 1.00 m/s.

[0085] Note that any fluid flow patterns, i.e. fluid flow directions and/or fluid velocities, around the body and/or the hull may be observed and determined by numerous measurement techniques. Examples of such measurement techniques are use of colorants in the water passing the body and the hull and/or use of light weight threads attached to the body and/or to the hull (as used in sails for sailboats). These measurement techniques may be complemented with, or replaced by, fluid flow data simulations.

General mode of operation of the invention

[0086] The invention comprises a streamlined body which in at least one load condition is fully or partly submerged in a mass of water when the vessel is lying motionless, positioned ahead of the hull behind, the body working in interaction with the hull behind. The body is formed and positioned such that it essentially displaces oncoming water masses in the vertical plane and then leads a mass of water under and/or out towards the sides of the hull behind, such that the hull itself, lying behind the body, displaces oncoming water masses to the least possible extent.

[0087] The aforementioned objects are thus achieved, namely that the vessel reduces its resistance to forward movement over a wide speed range, through:

- 1) reduced wave resistance; and/or
- 2) reduced or eliminated spray and wave-breaking resistance.

In addition, the seagoing characteristics of the vessel are improved.

[0088] The general mode of operation of the invention for the particular embodiment where the oncoming water masses are led under the hull, and the interaction between the body and the hull are explained in the rest of this section with the aid of Figures 9A and 9B. The position of water surface is shown by a broken line.

[0089] The invention reduces the resistance to forward movement of the vessel when the vessel operates above the aforementioned lower design speed. Above the lower design speed, the invention causes formation of a wave trough along a large part of the width of the hull by positioning a wide streamlined body ahead of the hull. The bottom of the wave trough is essentially determined by the defined trailing edge of

the body.

[0090] The wave trough is created by displacing a substantial proportion of the oncoming water mass in over the leading edge of the body, which is accelerated over the body's curved top surface. The whole or parts of the water mass are lifted, preferably above the water surface. At the rear top surface of the body, the water mass is lowered in the gravitational field and obtains increased relative velocity in relation to the vessel at the trailing edge of the body. As the water mass on the top surface of the body has increased relative velocity at the trailing edge of the body, the extent of the water mass in the vertical plane will decrease. This, together with the velocity vector of the water mass at the trailing edge of the body, forms the wave trough.

[0091] Because of the profile of the body and its transverse extent, the major part of the water mass that is lifted in front of the body (owing to the body's displacement of oncoming water masses) will be led in over the top surface of the body instead of escaping to surrounding water masses as waves. The whole of the water mass that is led in over the top surface of the body is accelerated and will to a great extent be isolated from the surrounding water masses. Displacement of oncoming water and change in water velocity at the top surface of the body thus results only to a small extent in waves in the surrounding water masses beyond the intended wave trough produced behind the body.

[0092] The underside of the body is shaped and/or angled to balance the whole or parts of the weight from the masses of water that pass over the top surface of the body, so that the forepart to the least possible extent undergoes a change in draught while at speed.

[0093] The hull bow area is located in the wave trough created at the rear edge of the body, so that the bow area itself does not displace water masses displaced by the body. The bow area remains dry or basically dry, while at speed. Further, the vessel's hull prevents the wave trough produced by the body from rising, thereby preventing the wave trough from propagating further in the surrounding water masses as waves.

[0094] The force exerted on the body in order to form the wave trough, so as to lead an oncoming water mass away from the bow area, will result in a resistance for the vessel. However, it is the case that a properly designed body will exert less resistance on the vessel than the wave resistance that is exerted on a vessel of conventional design.

[0095] While at speed in waves, the body acts as a stabiliser by countering pitching motions for the vessel. Oncoming waves will to a large extent be flattened out by the top surface of the body and led under the bow area without resulting in slamming against the bow area. The weight of the wave crests on the top surface of the body will seek to weigh the vessel down, and therefore a wave crest will not cause displacement buoyancy in the same way as for a conventional bow. Similarly, a wave trough will reduce the weight of the water mass at the top surface of the body.

[0096] The body will also be able to utilise parts of the potential energy that oncoming wave crests represent for forward movement when the wave crests is lowered in the gravitational field at the rear top surface of the body or as increased speed of the water mass that is led under the vessel's hull.

[0097] Since the vessel's seagoing characteristics are improved, waves will to a lesser degree limit the vessel's speed in waves.

[0098] To help understand the physics involved and how the invention is working, it should be noted that the velocity distribution of a water mass passing the top surface of a foil located close to the water surface, as is the case for the invention, will be fundamentally different from the same foil located deeper under the water surface. Figures 6A and B can help illustrate this. In Figure 6A it is shown a ball rolling in air over a profile having essentially the same shape as the foil shown in Figure 5A. The ball has an initial velocity V_0 at position 1 and at "the leading edge" of the profile at position 2. Due to the gravitational force, the velocity is gradually reduced until the ball reaches a minimum velocity V_{min} at the thickest part of the body profile at position 3. From position 3, via a position 4 at the rear top surface of the profile, to position 5, the velocity of the ball increases until the initial velocity V_0 has been regained at position 5. Figure 6B illustrates the velocity V of the ball graphically at position 1 to 5. When comparing Figure 6B with Figure 5B (sufficiently submerged foil) it can be seen that the velocity distribution of the two examples are fundamentally different.

[0099] Figures 7A, B and C illustrate schematically the streamlines of a mass of water flowing with an initial velocity V_0 over a foil in the direction of the double lined arrow. The straight water surface 5 is indicated in the figures.

- In Figure 7A the body is submerged deep under the water surface. The foil thus generates a lift, and the velocity of the water mass passing the top side of the foil is decreasing from the thickest part of the foil profile towards the trailing edge of the foil.
- In Figure 7B the body is submerged at an intermediate location under the water surface. The foil still generates a lift, and the velocity of the water mass passing the top side of the foil is still decreasing from the thickest part of the foil profile towards the trailing edge of the foil. The underpressure at the top side of the foil thus creates a wave trough at the water surface as indicated.
- In Figure 7C the body is located at, or close to, the water surface. With this arrangement of the top surface of the foil a lift is not generated, and the velocity of the water mass passing the top side of the foil is *increasing* from the thickest part of the foil profile towards the trailing edge of the foil, where the water mass might form a supercritical flow at the trailing edge.

Differences from the prior art

[0100] With reference to the description above, the invention differs from the prior art in the following areas:

Bulb:

1. 1. A bulb is designed to generate a wave in the surrounding water masses, which at a given speed is as much as possible in antiphase to the hull's wave system. The invention however is above the vessel's lower design speed, designed to produce a stationary wave trough, independent of the vessel's speed, in a large part of the hull width, and where the hull bow area is located such that the bow area itself displaces as little water as possible.
2. 2. A bulb works within a narrow speed range, whereas the invention works over a wide speed range.
3. 3. A bulb works in practice only at lower speeds determined by the distance between the bulb and the hull behind, whereas the invention also functions at higher speeds without the body being moved further forward.
4. 4. For a vessel with a bulb, it will essentially be the vessel's bow area that displaces oncoming water masses because of the limited area of the bulb seen from in front, whereas in the case of the invention it is the body that displaces all or a substantial proportion of the oncoming water masses and leads them away from the bow area.
5. 5. A bulb will displace approximately equally large water masses in the horizontal plane as in the vertical plane, whilst the body according to the invention essentially displaces the water masses in the vertical plane, as the body has a significantly larger width/height ratio than a bulb, seen from in front.
6. 6. A bulb does not have a defined trailing edge, unlike the body, which does have a defined trailing edge.
7. 7. A bulb, unlike the invention, is not designed to impart to the water particles that pass over its top surface a velocity and direction at its trailing edge that leads the water particles away from the bow area and/or essentially parallel to the bow area, such that the bow area itself displaces as little water as possible.

Thin wave-making plate (US 4,003,325):

1. 1. The thin plate according to US 4,003,325 is configured to make a wave in the surrounding water masses which, at a given speed, is as much as possible in antiphase to the hull's bow wave. The invention, on the other hand, is, above the vessel's lower design speed, designed to produce a stationary wave trough, independent of the vessel's speed, in a large part of the hull width where the bow area is located such that the bow area itself displaces as little water as possible.
2. 2. The thin plate according to US 4,003,325 works within a narrow speed range, whereas the invention works over a wide speed range.
3. 3. The thin plate according to US 4,003,325 works in practice only at lower speeds determined by the distance between the leading edge of the thin plate and the hull behind, whereas the invention also works at higher speeds without the body being moved further forward.
4. 4. For a vessel equipped with the thin plate according to US 4,003,325, it will essentially be the vessel's bow area that displaces oncoming water masses because of the limited area of the thin plate seen from in front; cf. US 4,003,325 with appurtenant fig. 5, whereas in the case of the invention, it is the body that displaces all, or a substantial proportion, of the oncoming water masses and leads them away from the bow area.
5. 5. The thin plate according to US 4,003,325 has a straight/planar top surface. The straight/planar top surface of the plate will thus not accelerate the water mass that passes on the top surface of the thin plate. The body according to the invention will, on the other hand, have a top surface that is configured to accelerate the water that passes on the body's top surface.
6. 6. The highest point of the thin plate according to US 4,003,325, seen from in front, is located lower than half the vessel's deepest draught when the vessel, without payload and without ballast, is lying motionless and is floating in a mass of water, unlike the body according to the invention.
7. 7. The straight/planar top surface of the plate according to US 4,003,325 can only to a very limited degree control the mass of water that passes over its top surface, whereas the primary object of the top surface of the body, on the other hand, is to be configured so that water mass on the top surface of the body is controlled and given a desired velocity vector at the trailing edge of the body.
8. 8. The thin plate according to US 4,003,325, unlike the invention, is not configured so that its top surface accelerates the water particles that pass the top surface to impart the water particles a velocity and direction at its trailing edge which leads the water particles away from the bow area and/or essentially parallel to the bow area, such that the bow area itself displaces as little water as possible.

Wing profile shaped flange (JPS58-43593U):

1. 1. The wing profile shaped flange according to JPS58-43593U seeks to reduce the height of a bow wave already formed by the vessel's bow area by giving the mass of water that forms the bow wave increased velocity at the top surface of the wing profile. The body according to the invention, on the other hand, is configured to impart to the water mass at its trailing edge a velocity and direction that leads the water mass away from the bow area and/or essentially parallel to the bow area before the water mass meets the bow area, so that the bow area itself displaces as little water as possible.
2. 2. The description in JPS58-43593U uses the term "wing profile-shaped flange" which means that the size of the wing profile is limited. According to JPS58-43593U, it is primarily the vessel's bow area that displaces oncoming water masses and the wing profile shaped flange displaces only a small proportion of the oncoming water masses the vessel must displace; cf. JPS58-43593U with appurtenant fig. 3. In the case of the invention, on the other hand, the body displaces all, or a substantial proportion, of the oncoming water masses and leads them away from the bow area.
3. 3. The top surface of the wing profile-shaped flange has an outer contour line, seen from in front, that lies adjacent to the bow area; cf. JPS58-43593U with appurtenant fig. 3 and fig. 1. The water mass that passes over the top surface of the flange therefore cannot be lowered in the gravitational field downstream of this contour line, in contrast to the invention.
4. 4. According to JPS58-43593U, the top surface of the wing profile-shaped flange, is not configured such that the oncoming water mass that passes over the top surface obtains a direction downstream of the contour line that leads the water mass away from and/or essentially parallel to the bow area, unlike at least one embodiment of the invention.
5. 5. According to JPS58-43593U, the leading edge of the wing profile shaped flange extends right out to the maximum width of the flange. The wing profile shaped flange therefore does not have a defined trailing edge.

Lifting foil (for example US 7,191,725 B2):

1. The solution in US 7,191,725 B2 describes bodies that are configured to create lift ("lifting body"). The object of the body according to the invention is not to create lift, but to prevent the formation of waves at the bow area.
2. The solution in US 7,191,725 B2 creates lift that reduces the vessel's draught while at speed, so that the vessel's total resistance is reduced. The body according to the invention is not configured to reduce the vessel's draught while at speed, so as thus to reduce the vessel's total resistance.
3. For a vessel with a lifting body according to US 7,191,725 B2, it will primarily be the vessel's bow area that displaces oncoming water masses because of the lifting body's limited area seen from in front and its location relative to the bow area, whereas in the case of the invention it is the body that displaces a substantial proportion of the oncoming water masses and leads them away from the bow area.
4. According to US 7,191,725 B2, the lifting body's highest point, seen from in front, is located lower than half of the vessel's deepest draught when the vessel, without payload and without ballast, is lying motionless and is floating in a mass of water, unlike the body according to the invention.
5. The lifting body according to US 7,191,725 B2, unlike the invention, is not configured to impart to the water particles that pass over its top surface a velocity and direction at its trailing edge that leads the water particles away from the bow area and/or essentially parallel to the bow area, such that the bow area itself displaces as little water as possible.
6. The water mass at the top surface of the lifting body according to US 7,191,725 B2 will have a decreasing velocity over its rear top surface, cf. Figure 7A and B. The water mass at the top surface of the body according to the invention will have an increasing velocity over its rear top surface, cf. Figure 7C.

Wing board (JP 1-314686):

1. The wing board according to JP 1-314686 is located at sufficient depth under the water surface to obtain a strong negative pressure region at the back surface of the wing board. This is in contrast to the invention where the top surface of the body is located sufficiently high relative to the water surface to avoid a substantial underpressure at the top surface of the body.
2. The wing board according to JP 1-314686 is designed and located to create a strong underpressure in a mass of water which shall equalize an overpressure created by the bow area of the hull (i.e. not create a wave crest and not create a wave trough). To the contrary, above the lower design speed of the vessel, the body according to the invention is designed to create a stationary wave trough, independent of the speed of the vessel, in a substantial part of the width of the hull, wherein the bow area is arranged such that the bow area itself displaces as little water as possible.
3. The wing board according to JP 1-314686 is located lower than half the vessel's deepest draught, when the vessel, without payload and without ballast, is lying motionless and is floating in a mass of water, contrary to the body according to the invention.
4. For a vessel with a wing board according to JP 1-314686, it will essentially be the vessel's bow area that displaces oncoming water masses because of the limited area of the wing board seen from in front. Whereas in the case of the invention it is the body that displaces all or a substantial proportion of the oncoming water masses and leads them away from the bow area.
5. The wing board according to JP 1-314686 will generate a substantial vortex. The body according to the invention is designed and arranged in such a way that a vortex is not created or to a smallest possible degree.
6. The wing board according to JP 1-314686 is, in contrast to the invention, not designed to give the water particles passing over its top surface a speed and direction at its trailing edge which leads the water particles away from the bow area and/or substantially parallel to the bow area (ref. also the vortex created by JP 1-314686) such that the bow area itself displaces as little water as possible.
7. The water mass at the top surface of the wing board according to JP 1-314686 will have a decreasing velocity over its rear top surface, cf. Figure 7B. The water mass at the top surface of the body according to the invention will have an increasing velocity over its rear top surface, cf. Figure 7C.

Vortex inducing wing (JP S60 42187A):

1. The wing according to solution in JP S60 42187A is designed to generate vortex having opposite direction of rotation to the wave breaking vortex generated by the bow of a ship. The body of the invention, on the other hand, is designed and arranged to prevent creation of a vortex.
2. The solution JP S60 42187A is designed to reduce the wave breaking resistance [CWB] from the bow area of a vessel. The invention, on the other hand, is designed to reduce the wave pattern resistance [CWP], the wave breaking resistance [CWB] and the spray resistance [CS] for a vessel (cf. Figure 1).
3. For the solution disclosed in JP S60 42187A it is mainly the bow area of the vessel that displaces the oncoming water masses since the area of the wing seen from in front is very limited (cf. fig. 5-14 of JP S60 42187A), whereas in the case of the invention it is the body that displaces all or a substantial proportion of the oncoming water masses and leads them away from the bow area.
4. The wing disclosed in JP S60 42187A is, in contrast to our invention, not designed to give the water particles passing over its top surface a speed and direction at its trailing edge which leads the water particles away from the bow area and/or substantially parallel to the bow area such that the bow area itself displaces as little water as possible (ref. also the vortex created by JP S60 42187A).

BRIEF DESCRIPTION OF FIGURES

[0101] Preferred embodiments of the present invention will now be described with reference to the attached figures, wherein:

Figure 1 is a graph indicating the different resistance coefficients as a function of Froude's number [F_N] which act on a typical prior art vessel moving at the surface of a water mass;

Figure 2 is a graph indicating the resistance to forward movement as a function of speed for model tests that use:

A: a vessel with a conventional bow according to the prior art;

B: a vessel with a modified bow according to a third embodiment of the invention without a V-wedge; and

C: a vessel with a modified bow according to a seventh embodiment of the invention without a V-wedge;

Figure 3A is a side view of a vessel with a bulb according to the prior art, which vessel is operated at design speed;

Figure 3B is a side view of the vessel according to Figure 3A, which vessel is operated above the design speed;

Figures 4A, B and C are front views of a prior art vessel with different bulb shapes, showing how the bulb shapes displace oncoming water masses;

Figure 5A is an illustration of a foil profile showing a typical underpressure distribution above its top surface when fully submerged and when a mass of water is flowing toward and across the foil with an initial velocity V_0 in the direction of the double lined arrow;

Figure 5B is a graph illustrating the corresponding velocity distribution of a water mass passing the top surface of the foil profile having the underpressure distribution shown in Figure 5A;

Figure 6A is an illustration showing the velocity vectors of a ball rolling in air over a profile similar to the foil profile shown in Figure 5A;

Figure 6B is a graph illustrating the velocity of the ball rolling in air shown in Figure 6A at different positions along the profile;

Figures 7A, B and C show a body, having the same angle of attack, and the resulting flow pattern of water flowing towards and above the body in the direction of the double-lined arrow when the body is located at different depths under the water surface. Figure 7A shows the flow pattern when the body is located deep under the water surface. Figure 7B shows the flow pattern when the body is located at an intermediate depth and Figure 7C shows the flow pattern when the body is located close to or at the water surface;

Figure 8A, B and C is showing a foil seen from above, from the side and from in front respectively. A water mass is flowing towards the foil in the direction of the double lined arrow. The curved arrows are illustrating the vortex generated at each side of the foil;

Figure 9A is a schematic vertical longitudinal section of a body according to the invention and shows waves created by the body alone when the vessel is moving above the lower design speed in a water mass;

Figure 9B shows schematically the interactions between the body and a hull according to the invention when the vessel is moving above the lower design speed in a water mass;

Figures 10A, B, C and D show the forepart of a vessel according to a first embodiment of the invention, where Figure 10A is a top view of the forepart, Figure 10B is a vertical longitudinal section of the forepart, Figure 10C is a front view of the forepart and Figure 10D is a bottom view of the forepart;

Figures 11A, B, C and D show the forepart of a vessel according to a second embodiment of the invention, where Figure 11A is a top view of the forepart, Figure 11B is a side view of the forepart, Figure 11C is a front view of the forepart and Figure 11D is a bottom view of the forepart;

Figures 12A, B, C and D show the forepart of a vessel according to a third embodiment of the invention, where Figure 12A is a top view of the forepart, Figure 12B is a side view of the forepart, Figure 12C is a front view of the forepart and Figure 12D is a bottom view of the forepart;

Figures 13A, B and C show the forepart of a vessel according to the first embodiment of the invention (also shown in Figures 10A-D) which to a greater degree illustrate the mode of operation of the invention, where Figure 13A is a top view of the forepart, Figure 13B is a vertical longitudinal section of the forepart and Figure 13C is a front view of the forepart;

Figures 14A, B, C and D show the forepart of a vessel according to the second embodiment of the invention (also shown in Figures 11A-D) which to a greater extent illustrates the mode of operation of the invention, where Figure 14A is a top view of the forepart, Figure 14B is a side view of the forepart, Figure 14C is a front view of the forepart and Figure 14D is a bottom view of the forepart;

Figures 15A, B, C and D show the forepart of a vessel according to the third embodiment of the invention (also shown in Figures 12A-D) which to a greater extent illustrates the mode of operation of the invention, where Figure 15A is a top view of the forepart, Figure 15B is a side view of the forepart, Figure 15C is a front view of the forepart and Figure 15D is a bottom view of the forepart;

Figure 16A shows a photograph of a model boat used in model tests seen at an angle from astern, with a conventional bow according to the prior art;

Figure 16B shows a photograph of a front view of the model boat in Figure 16A;

Figure 16C shows a photograph of a front oblique view of the model boat in Figure 16A;

Figure 17A shows photograph of a front view of the model boat where the bow section has been replaced by a modified bow according to the seventh embodiment of the invention.

Figure 17B is a photograph of a front oblique view of the model boat in Figure 17A;

Figure 18A is photograph of a front view of the model boat where the bow section has been replaced by a modified bow according to the third embodiment of the invention, with a V-wedge;

Figure 18B is a photograph of a front oblique view of the model boat in Figure 18A;

Figure 19A is a photograph where the model boat has a conventional bow according to the prior art as shown in Figures 16A-C, and where the measured speed is 1.25 m/s;

Figure 19B is a photograph where the model boat has a modified bow according to the third embodiment of the invention, as shown in Figures 18A and B, but without a V-wedge, and where the measured speed is 1.25 m/s;

Figure 19C is a photograph where the model boat has a modified bow according to the third embodiment of the invention, as shown in Figures 18A and B, but without a V-wedge, and where the measured speed is 1.34 m/s;

Figures 20A and B are photographs of the bow portion of the model boat with a modified bow according to the third embodiment of the invention, as shown in Figures 18A and B, but without a V-wedge, at a speed respectively below and above the lower design speed of the model boat;

Figures 21A, B, C and D show the forepart of a vessel according to a fourth embodiment of the invention, where Figure 21A is a top view of the forepart, Figure 21B is a side view of the forepart, Figure 21C is a front view of the forepart and Figure 21D is a bottom view of the forepart;

Figures 22A, B, C and D show the forepart of a vessel according to a fifth embodiment of the invention, where Figure 22A is a top view of the forepart, Figure 22B is a side view of the forepart, Figure 22C is a front view of the forepart and Figure 22D is a bottom view of the forepart;

Figures 23A, B, C and D show the forepart of a vessel according to a sixth embodiment of the invention, where Figure 23A is a top view of the forepart, Figure 23B is a side view of the forepart, Figure 23C is a front view of the forepart and Figure 23D is a bottom view of the forepart;

Figures 24A, B, C and D show the forepart of a vessel according to a seventh embodiment of the invention, where Figure 24A is a top view of the forepart, Figure 24B is a side view of the forepart, Figure 24C is a front view of the forepart and Figure 24D is a bottom view of the forepart;

Figures 25A and B are side views of the forepart of a vessel according to the invention where the trailing edge of the body is located higher than the hull bottom and deeper than the hull bottom, respectively;

Figures 26A, B, C, D, E and F show different configurations of how the vertical longitudinal section of the body can be formed according to the invention, Figure 26E shows examples of two bodies where one of the bodies is placed above the other, and Figure 26F shows a body comprising two parts;

Figures 27A, B, C, D and E are vertical longitudinal sections of different embodiments according to the invention and show how the dynamic lift of the body can be changed, where Figures 27B, C and D show how the flow at the trailing edge of the body can be changed by means of flaps/control surfaces; and

Figures 28A, B, C, D, E, F, G, H, I and J are top views of different configurations showing how the body can be configured, according to the invention.

DETAILED DESCRIPTION OF THE INVENTION

Definitions

[0102] Throughout this document, the following definition shall apply:

Vessel 1:

All displacement vessels and vessels that operate up to planing speeds.

Hull 2:

The part of the vessel 1 that is, or can come, in contact with water while at speed and which makes the vessel seaworthy, but not including the body 4 according to the invention, or bulb and the like for conventional vessels 1.

Bow area 3:

The area of the hull 2 seen from in front under the water surface 5 when vessel 1 is floating in a mass of water, but not including the body 4 according to the invention, or bulb and the like for conventional vessels 1.

The body 4:

The body that is arranged at the bow area 3.

Water surface 5:

A straight surface that the surface of the sea or the water forms when there are no waves.

Forepart of a vessel 6:

From amidships in the vessel's 1 longitudinal direction up to the vessel's 1 most forward point, i.e., including the body 4 according to the

invention, or bulb and the like for conventional vessels 1.

Bow wave:

A wave crest formed ahead of the bow area 3 because of the hull's 2 deceleration of the oncoming water mass.

The body's leading edge 41:

The foremost edge of the body 4, equivalent to "the leading edge" of an air plane wing.

The body's trailing edge 42:

The defined rearmost edge of the body 4, where the water masses from the body's top surface 47 leave the body 4, equivalent to "the trailing edge" of an air plane wing.

Forward top surface 43 of the body:

The top surface area of the body 4 that extends from the body's leading edge 41 to a contour line 53 of the body 4 seen from in front.

Rear top surface 44 of the body:

The top surface area of the body 4 that starts where the body's forward top surface 43 ends and extends back to the trailing edge 42 of the body.

Underside 45 of the body:

The underside area of the body 4 that extends from the leading edge 41 of the body to its trailing edge 42.

Forward part 46 of the body:

The volume of the body 4 that extends from the leading edge 41 of the body and backwards to a vertical cross-section through the contour line 53.

Top surface 47 of the body:

The top surface area of the body 4 that extends from the leading edge 41 of the body and backwards to its trailing edge 42.

Contour line 53:

A line that extends across the width of the body 4 on the body's top surface 47, formed by the highest visible point of the body 4 along the body's transverse direction when the body 4 is seen from in front. The tangent to the body 4 in the vessel's 1 direction of travel is thus horizontal at points of intersection along the whole contour line.

Interface 54:

The boundary between the body's leading edge 41 and its trailing edge 42.

Interface 55:

The boundary between the top surface 47 of the body and the bow area 3 or V-wedge 65.

Interface 56:

The boundary between the hull 2 bottom and the bow area 3.

V-wedge 65:

A device for securing the body 4 to the hull 2 and/or to improve the flow conditions at the trailing edge 42 of the body, where the device seen from above has a V-shape or approximate V-shape.

Lifted water mass 80:

The total water mass, including escaped water mass 80A, that is lifted above the water surface 5 as a result of the body's 4 displacement of oncoming water masses when the vessel 1 is at speed.

Escaped water mass 80A:

The part of the water mass that is lifted above the water surface 5 as a result of the body's 4 displacement of oncoming water masses when the vessel 1 is at speed and which escapes as waves to the surrounding water masses.

Velocity vector 85:

The water mass that passes over the top surface 47 of the body has at the trailing edge 42 of the body a velocity and a direction that can be given in the form of a velocity vector. This velocity vector is in turn the resultant of the velocity vector of each individual water molecule.

[0103] Figures 9A and B show the general mode of operation of the invention for the particular embodiment in which the oncoming water masses are led under the hull. The position of the water surface 5 is shown with broken line. Figure 9A shows the wave 31 formed behind the body 4 when only the body 4 is passed through a water mass above a lower design speed. Figure 9B shows the interaction between the body 4 and the hull 2 and how the hull 2 prevents the wave 31 from rising when the vessel 1 is operated above a lower design speed.

[0104] The invention can be configured in several ways, but the main principles of the mode of operation are common to all the embodiments.

A first embodiment

[0105] This section describes the structure and mode of operation of a first embodiment of a vessel 1 according to the invention. See Figures

10A, B, C and D and Figures 13A, B and C.

[0106] Figures 10A-D and Figures 13A-C show the forepart 6 of a vessel 1 comprising a hull 2 with a bow area 3 and a body 4 according to the invention, with the body 4 partly submerged in a water mass when the vessel 1 is lying motionless. The position of the water surface 5 is indicated in Figures 10B and C and in Figures 13B and C. The body 4 is located at a distance from the bow area 3 such that a passage 60 is formed between the body 4 and the bow area 3. As best shown in Figures 10A-D, the body 4 comprises a leading edge 41, a trailing edge 42, a forward top surface 43, a contour line 53, a rear top surface 44, an underside 45 and a forward part 46. The sum of the forward top surface 43 and the rear top surface 44 constitutes the body's top surface 47. The contour line 53 indicates the boundary between the forward top surface 43 and the rear top surface 44. The broken lines for the body's trailing edge 42, the contour line 53 and interface 56 in Figure 10A are not visible from above, but are shown in order to better illustrate the configuration of the hull 2 and the body 4.

[0107] With particular reference to Figures 13A-C, when the vessel 1 is at speed, and moves faster than a lower design speed, a water mass is displaced with laminar flow across the body's forward top surface 43. The body's 4 curved top surface 47, with tapering profile towards the trailing edge 42 of the body, accelerates the water mass and allows it to be lowered in the gravitational field. At the body's trailing edge 42, the water mass has a high velocity that results in the water mass having a smaller vertical extent. This, together with the velocity vector 85 of the water mass at the body's trailing edge 42, leads the volume of water under the bow area 3, such that the bow area 3 does not displace oncoming water masses. The bow area 3 is thus dry or basically dry while at speed.

[0108] Ahead of or upstream of the body 4, the water masses will be slowed down in the same way as ahead of a conventional ship's bow. This results in a lifted water mass 80 ahead of the body 4. The transverse extent of the body 4, and side plates 70 located on each side of the body 4 (cf. Figures 13A-C), lead a major part of the lifted water mass 80 in over the body 4, such that only a minor proportion 80A of the lifted water mass 80 ahead of the body 4 escapes as waves to the surrounding water masses. The lifted water mass 80 that is formed by the body 4, including the escaped water mass 80A, is illustrated in Figures 13A-C.

[0109] As the body 4 has a large transverse extent, delimited by side plates 70, and lifts oncoming water masses in the vertical plane, the water mass on the body's top surface 47 is isolated from the surrounding water masses, such that few or no waves are produced in surrounding water masses when the water mass is accelerated on the top surface 47 of the body. A water mass can thus be accelerated from point 200 to point 400 and here give the water mass a favourable velocity vector 85 (cf. Figure 13B) without significant waves being produced in the surrounding water masses.

[0110] Parts of the energy that help to lift the water mass 80 ahead of the body 4 accompany the water mass as potential energy in over the top surface 47 of the body, where the water mass is lowered in the gravitational field at the body's rear top surface 44. Thus, parts of the increased potential energy in the lifted water mass 80 are utilised for forward movement, or to give the water mass on the top surface 47 of the body increased speed at the trailing edge 42 of the body, instead of being lost to the surrounding water masses as waves.

[0111] As the body 4 is located close to the water surface 5, a lift is not obtained as is done with a sufficiently submerged lifting foil. The weight of the water masses on the body's top surface 47 will weigh the forepart 6 of the vessel 1 down. To counter this, the body's underside 45 can be shaped and/or angled to give a dynamic lift that balances the weight of the whole or parts of the water mass on the body's top surface 47. As can be seen from Figure 13B, the dynamic lift is created in that the body's underside 45 forms the angle of attack α to the horizontal plane. As the trailing edge 42 of the body is thus lowered, the velocity of the water mass on the body's top surface 47 increases further.

[0112] The distance between the trailing edge 42 of the body and the area in which the water masses strike the hull 2 is adapted such that the water mass flows with as much laminar flow as possible over the body's rear top surface 44 and further with as much laminar flow as possible to below points 500 and 600 (Figure 13B) where the hull 2 behind prevents wave formation. Points 100 and 300 are the location of the water masses respectively upstream of the leading edge 41 (i.e., upstream of point 200) and at the body's 4 highest point, along a flow line. Points 100, 200, 300, 400, 500 and 600 are also marked in Figure 13A.

[0113] The invention has thus reduced the formation of waves from the vessel 1 that spread to the surrounding water masses.

[0114] At increasing speed, the velocity of the essentially laminar flow on the body's top surface 47 will increase proportionally to the increase in the vessel's 1 speed, and thus prevent further accumulation of water masses 80 ahead of the body 4. The percentage 80A of the lifted water mass 80 ahead of the body 4 that escapes as wave will remain relatively constant. Similarly, the height of the lifted water mass 80 ahead of the body 4 will remain relatively constant, and thus the wave height formed by the forepart 6 of the vessel 1 will not increase as in the case of a conventional vessel 1.

[0115] The water mass on the top surface 47 of the body will, because of the Coanda effect, follow the body's top surface 47 also at high speeds.

[0116] The invention thus reduces the wave resistance of the vessel 1 within a wide speed range.

[0117] The laminar flow on the body's forward top surface 43 prevents spray and wave-breaking resistance and will therefore also reduce or eliminate these resistance components.

[0118] In this first embodiment, the body 4 can be secured to the hull 2 by means of the side plates 70 as shown in Figures 13A-C. The body 4 may also be secured to the hull 2 by one or more V-wedges 65 (see for example Figures 12A-D) between the bow area 3 and the body's top surface 47. At lower speed of the vessel 1, model tests have shown that it may be favourable to have a certain width of the V-wedge 65. This is

because the turbulence that easily arises when the water mass is to be led under the hull decreases, and/or that the area in which the turbulence is formed decreases. At higher speeds, the fastening means can be configured such that they slow down as little as possible the water masses flowing on the body's top surface 47.

A second embodiment

[0119] This section describes the structure and mode of operation of a second embodiment according to the invention. See Figures 11A, B, C and D and Figures 14A, B, C and D.

[0120] As the main principles for the mode of operation are common to all the embodiments, the following description will be similar to the explanation given in the section above.

[0121] Figures 11A-D and Figures 14A-D show the forepart 6 of a vessel 1 comprising a hull 2 and a body 4 according to the invention where the body 4 is incorporated in the bow area 3. Furthermore, the body 4 is partly submerged in a water mass when the vessel 1 is lying motionless. The position of the water surface 5 is indicated in Figures 11B and C and in Figures 14B and C.

[0122] As best shown in Figures 11A-D, the body 4 comprises a leading edge 41, two trailing edges 42, a forward top surface 43, a contour line 53, an interface 55, a rear top surface 44, an underside 45 and a forward part 46. The sum of the forward top surface 43 and the rear top surface 44 constitutes the body's top surface 47. The contour line 53 indicates the boundary between the forward top surface 43 and the rear top surface 44 and interface 54 indicate the boundary between the body's leading edge 41 and the body's trailing edges 42. The broken lines in Figure 11A that indicate the body's trailing edges 42, the contour line 53 and the interface 55 are not visible from above, but are shown in order better to illustrate the design of the hull 2 and the body 4.

[0123] With particular reference to Figures 14A-D, when the vessel 1 is at speed, and operates faster than a lower design speed, a water mass is displaced with laminar flow in over the body's forward top surface 43. The body's curved top surface 47 accelerates the water mass. As the body's rear top surface 44 is configured with a tapering cross-section out towards the periphery of the body 4 in the transverse direction, the water mass will be lowered in the gravitational field out at the body's trailing edges 42 without coming in contact with the bow area 3, such that undesired slowing down of the water mass on the body's top surface 47 is prevented. The configuration of the bow area 3 can, like the V-wedge 65, help to control the water mass at the body's top surface 47. At the body's trailing edges 42, the water mass has a high velocity that results in the water mass having a smaller vertical extent. This, together with the velocity vectors 85 of the water mass at the body's trailing edges 42, leads the water mass under the bow area 3 and/or out towards the sides of the hull 2. This means that the bow area 3 will only displace a small proportion of the oncoming water masses the forepart 6 of the vessel 1 must displace; cf. Figure 14C showing the front view of the vessel 1.

[0124] If the whole or parts of the water mass from the body's top surface 47 are not led under the bow area 3, the body 4 can be configured such that the velocity vectors 85 of water masses at the body's trailing edges 42 and the velocity vector of the oncoming water masses that are not displaced by the body 4, obtain a velocity vector that is as parallel as possible to the bow area 3.

[0125] Ahead of, or upstream of, the body 4, the water masses will be slowed down in the same way as ahead of a conventional ship's bow. This results in a lifted water mass 80 ahead of the body 4. The forward top surface 43 of the body has a tapering cross-section out towards the periphery of the body 4 in a transverse direction. This causes primarily a lifting of water masses 80 towards the middle of the body 4 and to a small extent out towards the body's 4 periphery, seen from in front. The transverse extent of the body 4 thus leads a major portion of the lifted water mass 80 in over the body 4, such that only a minor proportion 80A of the lifted water mass 80 ahead of the body 4 escapes as waves to surrounding water masses. The lifted water mass 80 and 80A formed by the body 4 is illustrated in Figures 14A and B.

[0126] As the body 4 has a large transverse extent, and also lifts oncoming water masses in the vertical plane, the water mass on the top surface of the body 47 is to a large extent isolated from the surrounding water masses, such that significant waves are not produced in surrounding water masses as a result of the water mass being accelerated on the body's top surface 47. A water mass can thus be accelerated from point 200 to point 400 (cf. Figures 14A-D) without significant waves being produced in the surrounding water masses. The water masses flow with as much laminar flow as possible under the hull 2 to point 500. Point 100 and point 300 are the location of the water masses respectively upstream of the leading edge 41 (i.e., upstream of point 200) and at the highest point of the body 4, along a flow line.

[0127] Parts of the energy that helped to lift the water mass 80 ahead of the body 4 accompany the water mass as potential energy in over the body's top surface 47 and is lowered in the gravitational field at the rear top surface 44 of the body. Thus, parts of the increased potential energy in the lifted water mass 80 are utilised for forward movement, or to give the water mass on the body's top surface 47 increased velocity at the trailing edges 42 of the body, instead of being lost to surrounding water masses as waves.

[0128] As the body 4 is located close to the water surface 5, a lift is not obtained as is done with a sufficiently submerged lifting foil. The weight of the water masses on the body's top surface 47 will weigh the forepart 6 down. To counter this, the body's underside 45 can be shaped and/or angled to give a dynamic lift that balances the weight the whole of or parts of the water mass on the body's top surface 47. As can be seen from Figures 14B and C, the dynamic lift is produced in that the body's trailing edge 42 is positioned lower than its leading edge 41. Thus, the velocity of the water mass on the body's top surface 47 increases further.

[0129] The invention has thus reduced the formation of waves from the vessel 1 that spread to the surrounding water masses.

[0130] If the vessel 1 is to be designed to travel at high speed, it will be expedient to allow the transverse extent of the body 4 to decrease from the body's 4 largest width and backwards, seen from above (i.e. downstream of interface 54), so as thus to lead a larger proportion of the water mass that passes through on the top surface 47 of the body under the bow area 3 instead of out towards the sides of the hull 2.

[0131] The laminar flow on the body's forward top surface 43 prevents spray and wave-breaking resistance and will therefore also reduce these resistance components.

[0132] The body 4 in this second embodiment is incorporated in the bow area 3 and secured to the hull 2 in that the hull 2 beams and support system are extended and continue on the interior of the body 4. This embodiment thus does not require any form of external strut or other form of external attachment.

A third embodiment

[0133] This third embodiment according to the invention, shown in Figures 12A, B, C and D and Figures 15A, B, C and D, has a structure and mode of operation that is somewhere between the two embodiments described above. The model boat, described later in this document under the section entitled Model tests is, in Tests B, made according to this third embodiment; cf. Figures 18A and 18B, but without the V-wedge 65.

[0134] Figures 12A-D and Figures 15A-D show the forepart 6 of a vessel 1 comprising a hull 2 with a bow area 3 and a body 4 according to the invention with the body 4 partly submerged in a water mass when the vessel 1 is lying motionless. The position of the water surface 5 is indicated in Figures 12B and C and in Figures 15B and C.

[0135] The body 4 is located at a distance from the bow area 3 such that passage 60 is formed between the body 4 and the bow area 3. As best shown in Figures 12A-D, the body 4 comprises a leading edge 41, a trailing edge 42, a forward top surface 43, a contour line 53, a rear top surface 44, an underside 45 and a forward part 46. The sum of the forward top surface 43 and the rear top surface 44 constitutes the body's top surface 47. The contour line 53 indicates the boundary between the forward top surface 43 and the rear top surface 44 and the interface 54 indicates the boundary between the body's leading edge 41 and its trailing edge 42. The body 4 is located a distance from the bow area 3 such that passage 60 is formed between the body 4 and the bow area 3. The broken lines for the body's trailing edge 42, the contour line 53, the interface 55 and the interface 56 in Figure 12A are not visible seen from above, but are shown in order better to illustrate the configuration of the vessel 1.

[0136] With particular reference to Figures 15A-D; when the vessel 1 is at speed and operates faster than a lower design speed, a water mass is displaced with laminar flow in over the body's forward top surface 43. The body's curved top surface 47, with tapering profile towards the trailing edge 42 of the body, accelerates the water mass and allows it to be lowered in the gravitational field. At the body's trailing edge 42, the water mass has a high velocity that causes the water mass to have a smaller vertical extent. This, together with the velocity vector 85 of the water mass at the trailing edge 42 of the body, leads the water mass under the bow area 3, such that the bow area 3 only displaces a small proportion of the oncoming water masses at the sides of the bow area 3; cf. Figure 15C. Large parts of the bow area 3 are thus dry or basically dry during motion.

[0137] Ahead of or upstream of the body 4, the water masses will be slowed down in the same way as ahead of a conventional ship's bow. This causes a lifted water mass 80 ahead of the body 4. The forward top surface 43 of the body has a tapering cross-section out towards the periphery of the body 4 in the transverse direction. This causes primarily a lifting of water masses 80 towards the middle of the body 4 and only to a small extent out towards the periphery of the body 4 in the transverse direction. The transverse extent of the body 4 thus leads a major part of the lifted water mass 80 in over the body 4, such that only a small proportion 80A of the lifted water mass 80 ahead of the body 4 escapes as waves to surrounding water masses. The lifted water mass 80 that is formed by the body 4, including escaped water mass 80A, is illustrated in Figures 15A and B.

[0138] As the body 4 has a large transverse extent and lifts oncoming water masses in the vertical plane, the water mass on the body's top surface 47 will to a large extent be isolated from the surrounding water masses, such that significant waves are not produced in surrounding water masses when the water mass is accelerated on the body's top surface 47. Thus, a water mass can be accelerated from point 200 to point 400, and here the water mass can be given a favourable velocity vector 85, (cf. Figures 15A-D) without significant waves being produced in the surrounding water masses.

[0139] Parts of the energy that help to lift the water mass 80 ahead of the body 4 accompany the water mass as potential energy in over the top surface 47 of the body, the water mass being lowered in the gravitational field at the rear top surface 44 of the body. Thus, parts of the increased potential energy in the lifted water mass 80 are utilised for forward movement, or to give the water mass on the body's top surface 47 increased velocity at the trailing edge of the body 42, instead of being lost to surrounding water masses as waves.

[0140] As the body 4 is located close to the water surface 5, a lift is not obtained as is achieved with a sufficiently submerged lifting foil. The weight of the water masses on the body's top surface 47 will weigh the forepart 6 down. To counter this, the body's underside 45 can be shaped and/or angled to give a dynamic lift that balances the weight of the whole or parts of the water mass on the body's top surface 47. As can be seen from Figures 15B and 14C, the dynamic lift is produced in that the body's trailing edge 42 is positioned lower than its leading edge 41. Thus, the velocity of the water mass on the body's top surface 47 increases further.

[0141] The distance between the body's trailing edge 42 and the area where the water masses meet the hull 2 is adapted such that the water mass flows with as much laminar flow as possible over the body's rear top surface 44 and further with as much laminar flow as possible under

the hull 2 to points 500 and 600 (Figure 15A-D) where the hull 2 behind prevents wave formation. Points 100 and 300 are the location of the water masses respectively upstream of the leading edge 41 (i.e., upstream of point 200) and at the body's 4 highest point, along a flow line.

[0142] The invention has thus reduced the formation of waves from the vessel 1 that spread to surrounding water masses.

[0143] With rising speed, the velocity of the essentially laminar flow on the body's top surface 47 will increase proportionally to the increase of the vessel's 1 speed, and thus prevent further accumulation of water masses 80 ahead of the body 4. The percentage 80A of the lifted water mass 80 ahead of the body 4 that escapes as wave will remain relatively constant. Similarly, the height of the lifted water mass 80 ahead of the body 4 will remain relatively constant at increasing speed, and thus the wave height formed by the forepart 6 will not increase as for a conventional vessel 1; cf. Figures 19A-C from the model tests.

[0144] The water mass on the body's top surface 47 will, because of the Coanda effect, follow the body's top surface 47 also at higher speeds.

[0145] Thus, the invention reduces the wave resistance within a wide speed range.

[0146] The laminar flow on the body's forward top surface 43 prevents spray and wave-breaking resistance and will therefore also reduce or eliminate these resistance components. This can be seen clearly from Figures 20A and B, which show respectively non-laminar and laminar flow characteristics of a displaced water mass that is lifted over the body's forward top surface 43.

[0147] The body 4 can in this third embodiment be secured to the hull 2 by means of one or more V-wedges 65, seen from above, as shown in Figures 12A-D, as also can be seen in Figures 18A and B. At lower speed of the vessel 1, model tests have shown that it may be favourable to have a certain width of the V-wedge 65. This is because the turbulence that easily arises when the water mass is to be led under the hull diminishes, and/or that the area where the turbulence is formed diminishes. At higher speeds, the body 4 can be fastened to the hull 2 using struts or plates so that the water masses on the top surface 47 of the body slow down as little as possible.

General design criteria - Miscellaneous

[0148] The body 4 and the hull 2 are configured so that the total resistance for the vessel 1 is as low as possible. The configuration and location of the body 4 is determined to a large extent by the hull's 2 draught, width/draught ratio, variation in draught (load/ballast) and speed range. In addition, regard must be had to seagoing characteristics and to what otherwise is a practical design in relation to the use of the vessel.

[0149] The body 4 should be configured such that maximum laminar flow is achieved at the body's top surface 47 from a lower design speed.

[0150] In general, an attempt can be made to lead a major proportion of oncoming water mass over the body's top surface 47. The proportion of water mass that must be displaced by the body's underside 45 and/or by the hull 2 is thus smaller. This can be advantageous as the water mass that is displaced by the body's underside 45 and/or by the hull 2 causes increased water velocity, which in turn causes negative pressure and loss of buoyancy, and also wave formation.

[0151] In the case of vessel 1 that operates at low to moderate speed, typically F_N 0.1- 0.25, it may be the dynamic pressure in oncoming water masses that limits the proportion of the oncoming water masses that is lifted over the forward top surface 43 of the body.

[0152] To obtain laminar flow over the body's forward top surface 43 at lower design speed, the body 4 can therefore be configured such that the body's 4 profile has little fullness at the body's forward part 46, and where the body's 4 forward underside may have a small angle of attack; cf. Figures 26B, 26C, 26D and 26F. This gives little deceleration of water masses ahead of the body 4. The rear underside of the body 4 may have a gradually increasing angle of attack to more easily lead water masses under the vessel 1; cf. Figures 26C, 26D and 26F.

[0153] Figure 26F has a gap that allows some water from the body's underside 45 to flow through the gap and up onto the body's rear top surface, so as thereby to improve the flow conditions in the area around the body's trailing edge 42, thereby reducing any turbulence problems. Such gap in the body 4 is prior art that is, inter alia, used in the aircraft industry.

[0154] Figure 26E shows an example of two bodies 4 that are located at different heights. A configuration of this kind can be used when a vessel 1 operates in different load conditions. When the vessel 1 operates with light load or ballast, the upper body 4 can be placed so high that water masses are not led over this body, but that the lower body 4 functions as otherwise described in this document. When the vessel 1 is heavily loaded, the water masses can pass over both bodies 4 and the effect of the bodies 4 here too will be as otherwise described in this document.

[0155] At higher speeds, where dynamic pressure is higher, it may be expedient to let a larger proportion of oncoming water be led over the body's top surface 47.

[0156] In the case of vessel 1 that operates at medium to higher speeds, typically from $F_N=0.25$ to over $F_N = 1.0$, it may be expedient to give body 4 about the same width as the hull 2.

[0157] In the case of hull 2 with a larger width compared to draught, typically barges, it may also be expedient to give the body 4 a width about the same as the width of the hull 2 so that the lifted water mass 80 in front of the hull is essentially led under the hull 2.

[0158] At a low width/draught ratio for the vessel 1, the body 4 can be configured to displace a larger proportion of oncoming water masses laterally than is the case with a larger width/draught ratio.

[0159] The cross-section of the body 4 out towards the periphery of the body 4 in the transverse direction can be made slimmer and thus reduce lifting of water masses 80 upstream of the body's 4 periphery; cf. Figures 11C, 12C, 21C, 22C and 23C.

[0160] For another embodiment, the trailing edges 42 of the body can also be configured parallel to the sides of the hull 2, so that more water is led out towards the sides of the hull 2.

[0161] The body 4 can be adapted such that its underside 45 or its leading edge 41 is positioned just above the water surface 5 when the vessel 1 is ballasted, such that the body's underside 45 physically prevents formation of a bow wave; cf. Figures 21A, B, C and D. When the vessel 1 is in loaded condition, the body 4 will be fully or partly submerged as otherwise described in this document.

[0162] The body 4 can be secured to the hull 2 in a fixed position. The attachment can also be effected such that the position of the body 4 in the vertical plane, horizontal plane and/or the angle of attack can be changed during motion. Furthermore, the body 4 can be equipped with one or more passive or active flaps at the trailing edge 42 of the body to minimise the total resistance for the vessel 1 to different depth/speed. Furthermore, active flaps can be used to reduce the vessel's 1 motions in waves.

[0163] The underside 45 of the body can be shaped and/or angled such that at speed a dynamic lift is generated from the body's underside 45, where the dynamic lift balances the whole or parts of the extra weight the water masses at the body's top surface exert on the body 4 when the vessel 1 is at speed. Since the weight from the water masses in the flow at the body's top surface 47 is essentially constant above a lower design speed, whilst the dynamic lift from the body's underside 45 increases with increasing speed, higher speed will require a smaller angle of attack. It may therefore be advantageous to construct a vessel 1 according to the invention where said angle of attack of the body 4 can be adjusted at speed, as indicated by arrows in Figure 27A. Furthermore, Figure 27B shows a body 4 fitted with one or more remote controlled flaps able to move as indicated by the arrow. The dynamic lift and the flow picture at the trailing edge 42 of the body will thus be capable of being changed at speed. Figure 27C shows body 4 fitted with one or more remote controlled flaps able to move as one or more of the arrows indicate. The dynamic lift and the flow picture at the trailing edge 42 of the body will thus be capable of being changed at speed. Figure 27D shows a body 4 fitted with one or more remote controlled flaps able to move as indicated by one or more of the arrows. The dynamic lift and the flow picture at the trailing edge 42 of the body will thus be capable of being changed at speed. The dynamic lift can also be provided by fitting the body 4 with one or more fixed and/or movable lifting foils at the underside 45 of the body. This is illustrated in a possible embodiment in Figure 27E. The arrows indicate how the angle of attack of the lifting foil can be changed at speed.

[0164] The underside 45 of the body can also be mounted at a small or no angle of attack, where necessary lift at the body's underside is generated by increase in pressure at the bow area 3 under body 4 as a result of displacement of oncoming water masses; cf. Figures 21B-D. The underside 45 of the body will thus also suppress formation of bow wave in at least one load condition.

[0165] Figures 21A-D show a forepart 6 of a vessel 1 comprising a hull 2 and a body 4 according to a fourth embodiment of the invention. As can be seen here, the body 4 comprises a leading edge 41, two trailing edges 42, a forward top surface 43, a contour line 53, a rear top surface 44, an underside 45 and a forward part 46. The sum of the forward top surface 43 and the rear top surface 44 constitutes the body's top surface 47. The contour line 53 indicates the boundary between the forward top surface 43 and the rear top surface 44, and the interfaces 54 indicate the boundary between the body's leading edge 41 and its trailing edges 42. The vessel water surface 5 is indicated in two load conditions, which also thus defines the bow area 3 for the two load conditions. The broken lines for the body's trailing edges 42, the contour line 53 and the interface 55 in Figure 21A are not visible from above, but are shown in order better to illustrate the configuration of the hull 2 and the body 4.

[0166] Sufficient water masses should be led over the body's top surface 47 with resulting velocity vector 85 at the trailing edge 42 of the body so that least possible turbulence is created between the body's trailing edge 42 and the bow area 3.

[0167] Increasing distance between the body's trailing edge 42 and the bow area 3 can lead to increasing turbulence problems, especially at lower speeds. The distance between the bow area 3 and the body's trailing edge 42 must also not be so small that the water masses from the body's top surface 47 are prevented from flowing under the hull 2.

[0168] The passage or channel 60 between the body 4 and the bow area 3 should be dimensioned so that the water mass that passes over the body 4 flows freely (i.e., with little or no deceleration) with maximum laminar flow further under the hull 2 and optionally out to the sides of the bow area 3. At deepest draught, there should be sufficient distance from the body's top surface 47 and the body's trailing edge 42 to the bow area 3 to allow the water masses on the body's top surface 47 to flow freely.

[0169] To counteract turbulent flow behind a body 4 that laterally displaces water masses at the body's trailing edge 42, (cf., for example, Figure 14A), it may be advantageous that water masses are also laterally displaced in a similar manner by the body's underside 45; cf., e.g., Figure 14D in which the broken lines illustrate flow lines at the body's underside 45.

[0170] The body 4, cf. e.g. the first embodiment, can be configured with or without side plates 70. The side plates 70 can be extended to the leading edge 41 of the body, or they can be extended further forward past the body's leading edge 41. In general, it can be said that the further forward the side plates 70 are extended, the smaller the proportion 80A of the lifted water mass 80 ahead of the body 4 will escape as wave in the surrounding water masses. If the body 4 is configured without side plates 70, the body 4 can be fastened to the bow area using

struts or plates that are not secured right out at the sides of the body 4, seen from in front. Furthermore, the body 4 can be secured using one or more V-wedges 65 as described in the first and the third embodiment. The body 4 can with these attachments also be configured with a tapering cross-section out towards the sides of the body 4 seen from in front, as shown in Figures 22A, B, C and D.

[0171] Figures 22A-D show the forepart 6 of a vessel 1 comprising a hull 2 and a body 4 according to a fifth embodiment of the invention with the body 4 completely submerged in a water mass when the vessel 1 is lying motionless. The position of the water surface 5 is indicated in Figures 22B and C. The body 4 is placed at a distance from the bow area 3 such that passage 60 is formed between the body 4 and the bow area 3. The body 4 comprises a leading edge 41, a trailing edge 42, a forward top surface 43, a contour line 53, a rear top surface 44, an underside 45 and a forward part 46. The sum of the forward top surface 43 and the rear top surface 44 constitutes the body's top surface 47. The contour line 53 indicates the boundary between the forward top surface 43 and the rear top surface 44. The broken lines for the body's trailing edge 42, the contour line 53, interface 56 and the fastening means in Figure 22A are not visible from above, but are shown in order better to illustrate the configuration of the hull 2 and the body 4.

[0172] Figures 23A-D show the forepart 6 of a vessel 1 comprising a hull 2 and a body 4 according to a sixth embodiment of the invention with the body 4 completely submerged in a water mass when the vessel 1 is lying motionless. The position of the water surface 5 is indicated in Figures 23B and C. The body 4 is placed at a distance from the bow area 3 such that passage 60 is formed between the body 4 and the bow area 3. The body 4 comprises a leading edge 41, a trailing edge 42, a forward top surface 43, a contour line 53, a rear top surface 44, an underside 45 and a forward part 46. The sum of the forward top surface 43 and the rear top surface 44 constitutes the body's top surface 47. The contour line 53 indicates the boundary between the forward top surface 43 and the rear top surface 44, and the interfaces 54 indicate the boundary between the body's leading edge 41 and its trailing edge 42. The broken lines in Figure 23A that indicate the body's trailing edge 42, the contour line 53 and the interfaces 55 and 56 are not visible from above, but are shown in order better to illustrate the configuration of the hull 2 and the body 4.

[0173] Figures 24A-D show the forepart 6 of a vessel 1 comprising a hull 2 and a body 4 according to a seventh embodiment of the invention. The model boat, described later in this document under the section entitled Model tests, is in Test C made according to this seventh embodiment; cf. Figures 17A and B. This embodiment combines the properties as described in the first embodiment with the properties of a pointed conventional bow. The position of the water surface 5 is indicated in Figures 24B and C. The body 4, seen from in front, does not in this embodiment extend out to the largest width of the vessel 1. The body 4 is positioned at a distance from the bow area 3 behind such that passage 60 is formed between the body 4 and the bow area 3, as described in the first embodiment of the invention. The body 4 comprises a leading edge 41, a trailing edge 42, a forward top surface 43, a contour line 53, a rear top surface 44, an underside 45 and a forward part 46. The sum of the forward top surface 43 and the rear top surface 44 constitutes the body's top surface 47. The contour line 53 indicates the boundary between the forward top surface 43 and the rear top surface 44. The broken lines for the body's trailing edge 42, the passage 60, the contour line 53 and interfaces 56 in Figure 24A are not visible from above, but are shown in order better to illustrate the configuration of the hull 2 and the body 4. Further, the broken lines in Figure 24D mark the boundary between the body 4 and the hull 2.

[0174] In heavy sea, the top surface 47 of the body will flatten out oncoming waves and lead them under the hull 2 such that the bow area 3 to a lesser extent encounters resistance from waves. It may therefore be advantageous with sufficient distance between the body's top surface 47 and the bow area 3 to allow waves of a certain height to pass freely in the passage 60 between the top surface 47 of the body and the bow area 3, and then be led under the hull 2.

[0175] Furthermore, it may be an advantage in a higher sea that the hull 2 is given a bow configuration as shown in Figures 23A-D and Figures 24A-D where oncoming high sea that cannot pass freely in the passage 60 between the body 4 and the bow area 3 thus can as freely as possible be displaced laterally.

[0176] In a high sea slamming may also occur at the body's underside 45. To counteract this, the body's underside 45 can be made curved or V-shaped, seen from in front; cf. respectively Figures 14B-C and Figures 23B-C. Furthermore, the body's leading edge 41 can be rounded (cf. Figures 14A and D), or the body 4 can be made with a "sweep back" configuration; cf. Figures 23A-D. The body's 4 area at the underside may also be critical since smaller area can give less slamming. By positioning the body 4 deeper in the water mass, the body's underside 45 may also be less exposed to slamming.

[0177] Figures 25A and B show the forepart 6 of a vessel 1 comprising a hull 2 and a body 4 according to the invention where the highest point of the body 4 is located at the water surface 5. The body's trailing edge 42 is located higher and lower than the hull 2 bottom, respectively. At low speed, it may be an advantage that the body's trailing edge 42 is located lower than the hull 2 bottom, in part because the turbulence problems that may arise when the water mass from the body's top surface 47 is to be led under the hull 2 will thus be smaller.

[0178] The body's 4 radius, seen in a vertical section in the vessel's 1 direction of travel, at the leading edge 41 of the body may be important for the body's 4 seagoing characteristics. If the radius of the body 4 here is unduly sharp, i.e., with small radius at the body's leading edge 41 (cf., e.g., Figures 26B, C and D), cavitation and turbulence may occur when the vessel 1 is at speed and/or is exposed to waves. A configuration of the body's leading edge 41 as shown in Figure 26A may be more advantageous as regard cavitation. Furthermore, cavitation problems may occur if there are other areas on the top surface 47 and/or underside 45 with a small radius of curvature. By small here is meant substantially smaller than typical dimensions for the body 4, for example, a radius of curvature of less than 20% of the body's length.

[0179] Since a vessel 1 designed according to the invention has reduced wave resistance at increasing speed compared to a conventional vessel 1, and since the vessel's 1 wave resistance is less dependent on the length of the vessel 1, it may be advantageous to design the vessel 1 according to the invention with larger width and smaller length compared with a conventional vessel 1. A vessel 1 according to the invention with the same load capacity as a conventional vessel 1 can thus be less costly to build.

[0180] The top surface 47 of the body may have a single, double or triple curvature, as illustrated respectively in Figures 26A, B and C. The top surface 47 may also have one or more straight portions. Furthermore, the body's 4 contour line 53 can be moved forwards or backwards in the longitudinal direction of the body 4 with reference to what is shown in Figures 26A-D. The body 4 may have different profiles and profile thicknesses across the transverse extent of the body 4. The body's underside 45 can be straight (cf. Figure 26B) or have a single curvature (cf. Figures 26A and D) or have a double curvature (cf. Figure 26C). The body 4 can be made as one or more combinations of Figures 26A-D.

[0181] However, the configurations shown in Figures 26A-D are not exhaustive as regards showing all possible configurations of the body 4.

[0182] If it is desirable to steer the water masses in towards the middle of the body 4, the body 4 can in an alternative embodiment be made with most fullness out towards the periphery of the body 4 in the transverse direction and least fullness about the centre axis, seen from in front.

[0183] Furthermore, the rear top surface 44 of the body can be made with a defined/marked trailing edge 42, for example, pointed or almost pointed, where the defined trailing edge 42 can be located lower than the body's leading edge 41.

[0184] The body's leading edge 41 seen from above can be made straight, concave, convex, "sweep back", "forward sweep" or a combination thereof. The same applies to the body's trailing edge 42. Figures 28A-J illustrate examples of these and show the body's top surface 47, seen from above. The arrow indicates the direction of flow of the water mass. The body's leading edge 41, trailing edge 42 and interface 54 are indicated. However, Figures 28A-J are not exhaustive as regards showing all possible configurations of the body 4.

[0185] The body's top surface 47 and underside 45 can be configured with a V or U shape, seen from in front, when the vessel 1 is lying motionless in order to be adapted for heeling. This will be particularly relevant for sailing boats.

[0186] The width of the body 4 seen from in front should normally be between 50 and 100% of the hull 2 width for the first, second, third, fourth, fifth and sixth embodiment. For the seventh embodiment, the width of the body 4 seen from in front can also be smaller than 50% of the width of the hull 2.

[0187] Seen from in front, the body 4 should preferably have a width/height ratio greater than 1.5.

Model tests

[0188] To document the invention and its mode of action, and to verify change of resistance to forward movement, the inventor has carried out tests using a model boat.

[0189] To be able optimally to compare the resistance to forward movement for different configurations of the forepart 6 of a vessel 1, the model boat has interchangeable bow sections. It is thus easy to switch between different bow sections whilst the rest of the model boat has the same structure. Repeated runs can thus be carried out under otherwise identical conditions.

[0190] The model boat is radio-controlled using an electric propulsion engine. The battery is well dimensioned so that the voltage loss is insignificant. The propeller shaft of the model is mounted horizontally or close to horizontally, and is supported by simple brass bearings which does not absorb thrust forces. The propeller shaft is mounted directly on the electric motor, which in turn is mounted in a carriage which rolls smoothly in the direction of the propeller shaft. The carriage does absorb the torsional moment of the propeller and the electric motor, but not the propellers thrust-forces. The carriage impinges a pressure sensor so that the propellers thrust-force in Newton [N] may be logged. When the model boat is driven with constant speed the thrust-force from the propeller is equal to the propulsion resistance of the model boat. The speed of the model boat is measured by a GPS logger. The test results of achieved speed [m/s] and the propulsion resistance [N] are for each of the three model tests plotted in Figure 2 as tests A, B and C. Based on the length and speed of the model the models Froude number [F_N] is also provided along the x axis. For each measuring point the average thrust-force is registered through a time period of 5-10 seconds and correspondently plotted against the speed during the same time period.

[0191] In Test A the model boat is driven using a conventional bow configuration according to the prior art, as shown in Figures 16A, B and C.

[0192] In Test B the model boat is driven using a modified bow configuration according to the third embodiment of the invention without a V-wedge 65, as described earlier in this document. The bow sections in Test B is the same as shown in Figures 18A and B with the exception that the modified bow configuration in Figure 18A and B is shown with a V-wedge 65. The body 4 is in Test B secured to the model boat using a thin plate, as can be seen in Figure 20A.

[0193] In Test C the model boat is driven using a modified bow configuration according to the seventh embodiment of the invention as shown in Figures 17A and B, and as described earlier in this document, cf. Figures 24A, B, C and D.

[0194] The model boat with a conventional bow in Test A is built as a typical displacement hull. The model has a maximum length of 154 cm and a width of 33 cm. The transition between the model boat's hull sides and bow area 3 is about 115 cm from the stern of the model boat. During the model tests the model boat weighed 34.5 kg, which gave a draught of about 9.7 cm. The model boat was trimmed such that it had almost neutral trim when it lay motionless and floated in the water. Neutral trim means to say that the model boat is oriented such that the bottom of the model boat is parallel to the water surface 5.

[0195] The model boat in Tests B has a maximum length of 153.5 cm. The width, weight and trim of the model are otherwise unchanged from Test A. The draught of the model boat was about 10.2 cm. The maximum width of the body 4, seen from in front, is 33.0 cm and the body's 4 maximum length, seen from the side, is 31.0 cm. The maximum vertical thickness of the body 4 is 8.0 cm and is located about 13 cm from the foremost point on the body's leading edge 41. The body's trailing edge 42 is positioned 1.0 cm above the bottom of the model boat. The foremost point on the body's leading edge 41 in the vessel's 1 direction of travel is located 4.9 cm higher than the bottom of the model boat. The curvature in the transition between the model boat's bottom and the bow area 3 has a radius of about 15.0 cm. The distance of the passage 60 between the body's trailing edge 42 and the hull 2, measured in the horizontal plane, is about 11.0 cm. The distance of the passage 60 between the body's top surface 47 and the hull 2, measured perpendicular to the body's top surface 47 is about 6.0 cm. The radius of the curvature in the transition between the sides of the model boat and the bow area 3 is about 5.5 cm.

[0196] The model boat in Test C has a maximum length of 154 cm. The width, weight and trim of the model are otherwise unchanged from Test A. The draught of the model boat was about 9.8 cm. The width of the body 4, seen from in front, is 16 cm and the body's 4 length, seen from the side, is 26.5 cm. The body's 4 maximum vertical thickness is 4.0 cm and is located 12 cm from the body's leading edge 41. The trailing edge 42 of the body is located at the same height as the model boat's bottom. The foremost point on the body's leading edge 41 is located 4.7 cm higher than the model boat's bottom. The curvature between the model boat's bottom and the bow area 3 forming the passage 60 has a radius of about 10 cm. The distance of the passage 60 between the body's trailing edge 42 and the hull 2, measured in the horizontal plane is about 7.0 cm. The distance of the passage 60 between the body's top surface 47 and the hull 2, measured perpendicular to the body's top surface 47, is about 8 cm. The transition between the model boat's hull sides and the bow area 3 is about 110 cm from the stern of the model boat, where the bow area 3 begins with a convex shape and then a concave shape as can be seen in Figure 17A.

[0197] As can be seen from the estimated curves in Figure 2, the modified bow in Test B has lowest resistance to forward movement at speeds above about 1.23 m/s, whilst the modified bow in Test C gives lower resistance to forward movement in the speed range between about 1.03 m/s and 1.23 m/s. The propulsion resistance for the conventional bow in Test A is lower than the two alternatives with modified bow below about 1.03 m/s

[0198] Figures 19A, B and C show photographs taken during model tests. Figure 19A is taken when the model is fitted with the conventional bow configuration as in Test A, whilst Figures 19B and C are taken when the model is fitted with the modified bow configuration, as in Test B. Measured speed for Figures 19A, B and C is respectively 1.25 m/s, 1.25 m/s and 1.34 m/s. It is shown visually in Figures 19A, B and C that the wave formation from the model with a modified bow according to the invention is substantially smaller than the same model with a conventional bow configuration.

[0199] From the estimated curves in Figure 2 at a speed of 1.25 m/s, which is the speed of the model boat in Figure 19A and B, it can be read that the model boat with a conventional bow configuration in Test A is given about 38.3% more propulsion resistance than the model boat with a modified bow in Test B (the estimated propulsion resistance is respectively 10.44 N and 7.55 N).

[0200] If the model boat is scaled up 50 times, a full-scale ship will be obtained that is 77 metres long. A speed of the model boat of 1.25 m/s will correspond to a speed of 8.84 m/s for the full-scale ship by using the equation (1) given above, corresponding to 17.2 knots. At this speed, the model test indicates that the full-scale ship built with a conventional bow according to the model used in Test A will be given 47.1% more propulsion resistance than the full-scale ship built with a modified bow according to the model used in Test B (the calculated propulsion resistance is respectively 1,158 KN and 787 KN). The measurement data were translated from the model to full scale according to procedure described by Håvard Holm and Sverre Steen - Motstand og framdrift - NTNU (Norway). It is assumed that the model boat with conventional and with modified bow will have a wetted surface of $S_m=0.71 \text{ m}^2$, and further that both will have a length in the water line $L_{vl,m}=1.54 \text{ m}$.

[0201] In the preceding description, different aspects of the vessel according to the invention have been described with reference to the illustrative embodiments. For the purpose of providing a thorough understanding of the vessel and its mode of operation, explanations, specific numbers, systems and configurations have been presented. However, this description is not intended to be interpreted in a limiting manner. Different modifications and variations of the illustrative embodiments, as well as other embodiments of the vessel that will be obvious to those of skill in the art regarding the described content, will be within the scope of the present invention.

REFERENCES CITED IN THE DESCRIPTION

This list of references cited by the applicant is for the reader's convenience only. It does not form part of the European patent document. Even though great care has been taken in compiling the references, errors or omissions cannot be excluded and the EPO disclaims all liability in this regard.

Patent documents cited in the description

- [US4003325A](#) [0016] [0017] [0100] [0100] [0100] [0100] [0100] [0100] [0100] [0100] [0100] [0100]
- [JPS5643593U](#) [0020] [0022] [0100] [0100] [0100] [0100] [0100] [0100] [0100] [0100]
- [US7191725B2](#) [0028] [0100] [0100] [0100] [0100] [0100] [0100] [0100]
- [JP1314666A](#) [0029] [0030] [0031] [0031] [0031] [0031] [0032] [0033] [0100] [0100] [0100] [0100] [0100] [0100] [0100] [0100]
- [JPS6042187A](#) [0034] [0035] [0037] [0037] [0100] [0100] [0100] [0100] [0100] [0100] [0100]

- US6467422B1 [0050]
- GB992375A [0050]
- JPH0656067A [0050]
- US4335671A [0050]

PATENTKRAV

1. Fartøj (1), der omfatter

et skrog (2) med et bovområde (3) defineret som skrogets (2) overfladeområde set forfra under en vandoverflade (5), når fartøjet (1) ligger stille og flyder i en vandmasse; og

5 et legeme (4) anbragt ved bovområdet (3), hvor legemet (4) endvidere omfatter:

en forkant (41);

en bagkant (42) placeret på nedstrømssiden af forkanten (41);

en underside (45) og

10 en øvre overflade (47), der endvidere omfatter en øvre overflade (43) fortil, der strækker sig fra legemets forkant (41) til en ydre konturlinje (53) af legemet (4) set forfra; og hvor legemets (4) højeste punkt, set forfra, er placeret højere end halvdelen af fartøjets (1) største dybgang, når fartøjet (1), uden nyttelast og uden ballast, ligger stille og flyder i en vandmasse,

kendetegnet ved, at legemets (4) vertikale sektion gennem fartøjets (1) bevægelsesretning og legemets (4) udstrækning i skrogets (2) tværretning, i mindst én af 15 fartøjets (1) lasttilstande, er designet til forskydning af en modgående vandmasse over legemets øvre overflade (47) ved en hastighed for fartøjet (1), der er lig med eller større end en lavere dimensioneringshastighed defineret som den laveste hastighed for fartøjet (1), hvor den modgående vandmasse, der primært forskydes i et vertikalt plan langs fartøjets (1) 20 bevægelsesretning, opnår en i alt væsentlig laminær strøm over den øvre overflade (43) af legemet fortil, og hvor udformningen af legemets øvre overflade (47) accelererer den modgående vandmasse, der sænkes i tyngdefeltet på nedstrømssiden af konturlinjen (53), således at den modgående vandmasse når en hastighed og retning ved legemets bagkant (42), der leder den modgående vandmasse væk fra bovområdet (3), eller i alt væsentligt parallelt 25 med bovområdet (3), eller en kombination deraf, hvor legemets (4) område set forfra, udgør mere end 20 % af delen af bovområdet (3) placeret bag legemet (4) mellem de to vertikale plan i fartøjets (1) bevægelsesretning med en afstand, der svarer til legemets (4) maksimale bredde.

2. Fartøj (1) ifølge krav 1, kendetegnet ved, at legemets øvre overflade (47) endvidere er 30 således udformet, at den modgående vandmasse opnår en retning på nedstrømssiden af konturlinjen (53), der leder den modgående vandmasse væk fra bovområdet (3), eller i alt væsentligt parallelt med bovområdet (3), eller en kombination deraf.

3. Fartøj (1) ifølge krav 1 eller 2, kendetegnet ved, at legemets forkant (41) strækker sig

ud til legemets (4) største bredde set ovenfra.

4. Fartøj (1) ifølge et eller flere af de foregående krav, kendetegnet ved, at legemet (4) er således indrettet, at dets forkant (41) er under eller i vandoverfladen (5) i mindst én af fartøjets
5 (1) lasttilstande, når fartøjet (1) ligger stille og flyder i en vandmasse.
5. Fartøj (1) ifølge et eller flere af de foregående krav, kendetegnet ved, at legemet (4) er således placeret, at det højeste punkt af legemet (4), set forfra, er placeret højere end $3/4$ af fartøjets (1) største dybgang, beregnet fra det laveste punkt af fartøjet (1), når fartøjet (1), uden
10 nyttelast og uden ballast, ligger stille og flyder i en vandmasse.
6. Fartøj (1) ifølge et eller flere af de foregående krav, kendetegnet ved, at legemets konturlinje (53) og forkanten (41) af legemet, i mindst én af fartøjets (1) lasttilstande, er således placeret, at mere end 20 % af den modgående vandmasse løftes over vandoverfladen
15 (5) ved en hastighed for fartøjet (1), der er lig med eller større end den lavere dimensioneringshastighed.
7. Fartøj (1) ifølge et eller flere af de foregående krav, kendetegnet ved, at bagkanten (42) af legemet, set i en vertikal retning, har en form, der er identisk med, eller næsten identisk med
20 bagkanten af et bæreplan.
8. Fartøj (1) ifølge et eller flere af de foregående krav, kendetegnet ved, at legemets (4) vertikale sektion i fartøjets (1) bevægelsesretning og udstrækningen af legemet (4) i skrogets (2) tværretning, i mindst én af fartøjets (1) lasttilstande, er således udformet, at mere end 20 %
25 af den modgående vandmasse, der passerer over legemets øvre overflade (47) ved en hastighed for fartøjet (1), der er lig med eller større end den lavere dimensioneringshastighed, ledes under skroget (2).
9. Fartøj (1) ifølge et eller flere af de foregående krav, kendetegnet ved, at legemet (4) er anbragt i en afstand fra bovområdet (3), således at mindst én passage (60) er dannet mellem
30 legemet (4) og bovområdet (3).
10. Fartøj (1) ifølge et eller flere af de foregående krav, kendetegnet ved, at bagkanten (42) af legemet er anbragt i en afstand fra bovområdet (3), således at skroget (2), i mindst én af

fartøjets (1) lasttilstande, forhindrer den del af den modgående vandmasse, der ledes under skroget (2), i at stige, når fartøjets (1) hastighed er lig med eller højere end den lavere dimensioneringshastighed.

- 5 11. Fartøj (1) ifølge et eller flere af de foregående krav, kendetegnet ved, at den maksimale tværskibsudstrækning (B) af legemet (4) divideret med legemets (4) maksimale højde (H), set forfra, er større end 1,5.
12. Fartøj (1) ifølge et eller flere af de foregående krav, kendetegnet ved, at legemet (4) har
10 en maksimal tværskibsudstrækning, set forfra, der er mindst $\frac{3}{8}$ af skrogets (2) maksimale bredde, set forfra.
13. Fartøj (1) ifølge et eller flere af de foregående krav, kendetegnet ved, at den vertikale position af legemet (4) i forhold til vandoverflade (5) er, i mindst én lasttilstand, således at den
15 modgående vandmasse ved legemets øvre overflade (47) på nedstrømsiden af den maksimale tykkelse af legemet (4), målt langs fartøjets (1) bevægelsesretning og 90 grader på legemets (4) kordelinje, opnår en i alt væsentligt konstant eller tiltagende hastighed, ved en hastighed for fartøjet (1), der er lig med eller større end den lavere dimensioneringshastighed.
- 20 14. Fartøj (1) ifølge et eller flere af de foregående krav, kendetegnet ved, at legemets (4) tværsnitsareal, set forfra, aftager i højde mod periferierne i legemets tværretning, således at trykopybygningen ved legemets (4) underside (45) og trykopybygningen ved legemets (4) øvre overflade (47) i alt væsentligt er udlignet ved legemets (4) periferier.
- 25 15. Fartøj (1) ifølge et eller flere af kravene 1-13, kendetegnet ved, at periferien ved hver tværside af legemet (4) omfatter en plade, der strækker sig over en større del af legemet (4) langs fartøjets bevægelsesretning, hvor pladens geometriske form er således designet, at trykket ved legemets (4) underside (45) ikke har nogen eller har en uvæsentlig indvirkning på trykket ved legemets (4) øvre overflade (47).

DRAWINGS

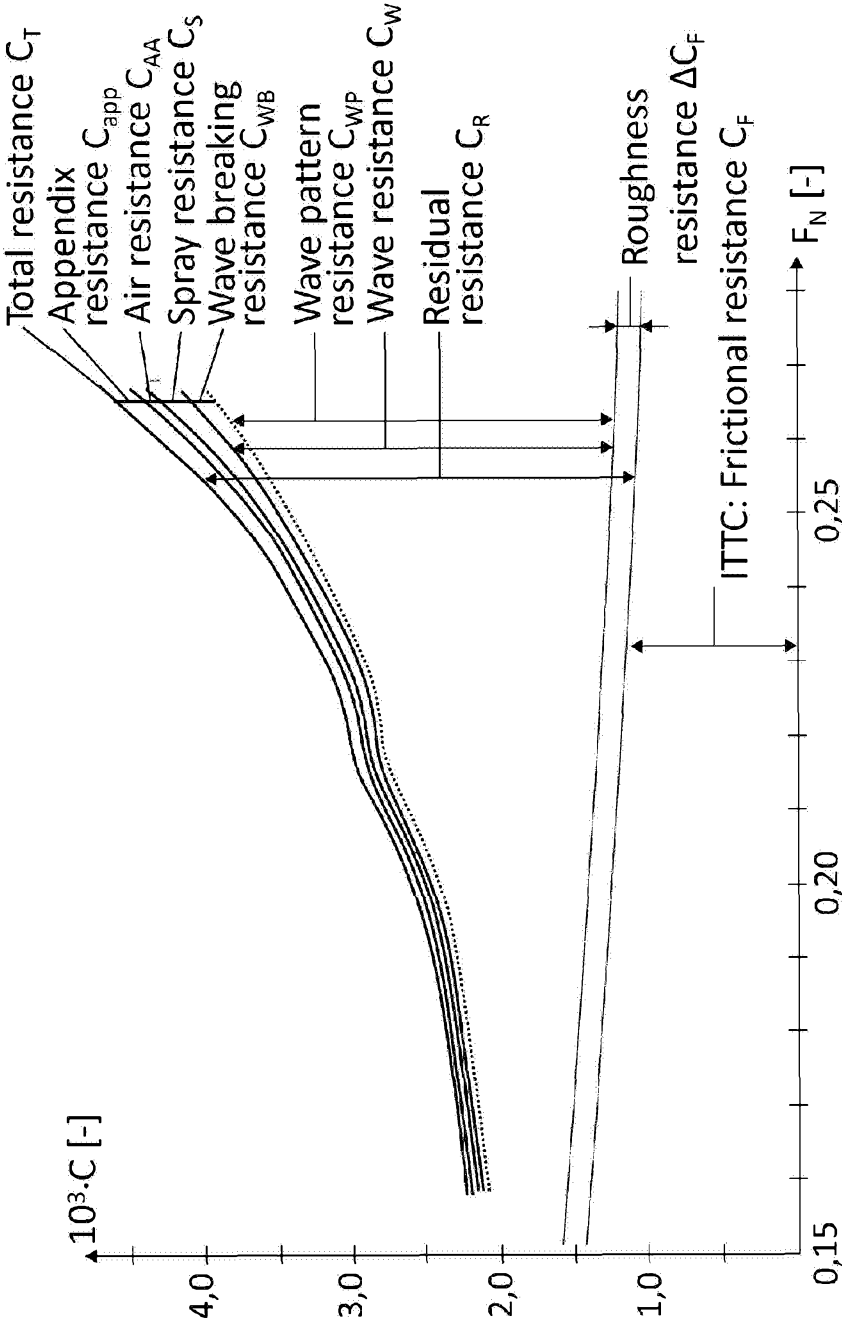

Figure 1

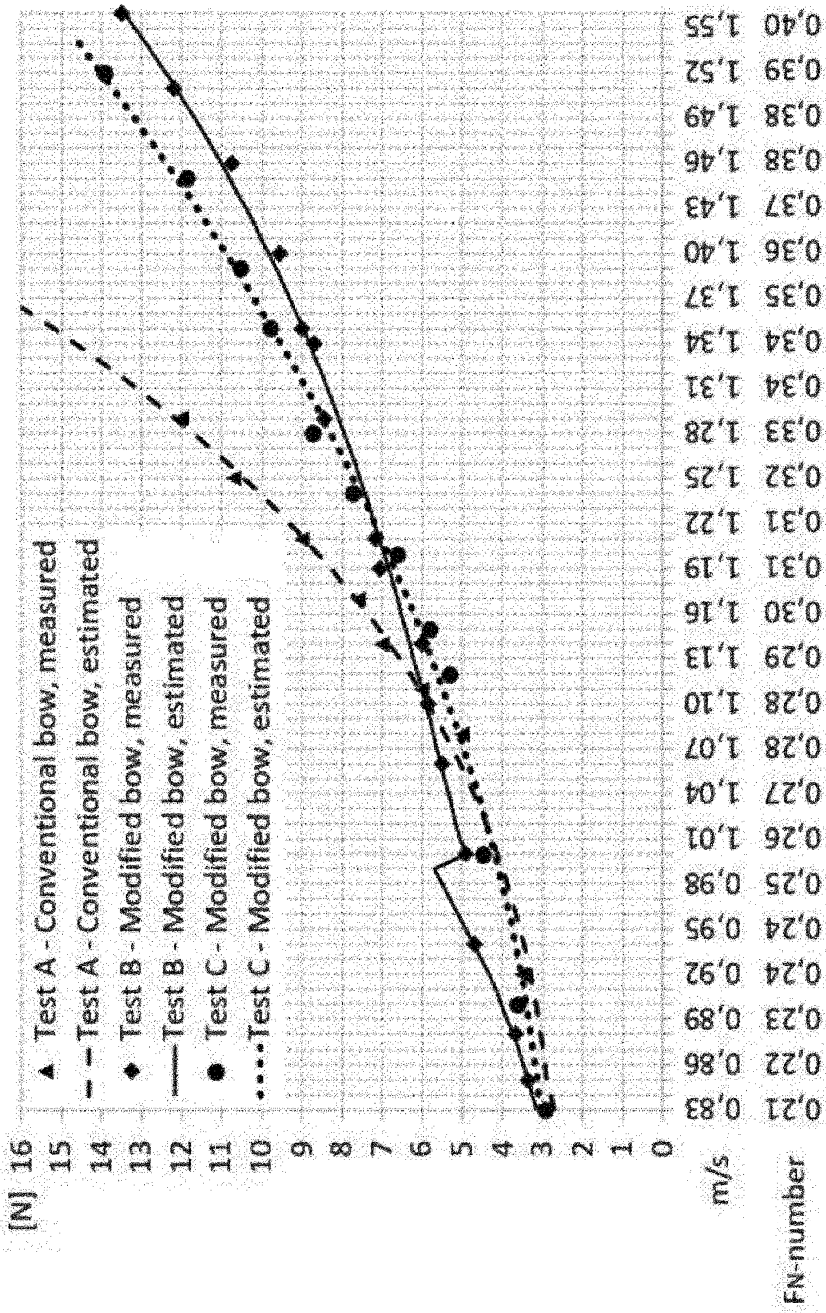
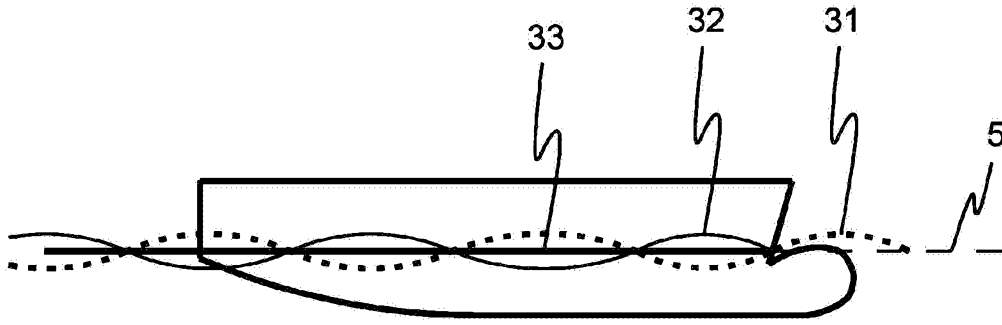
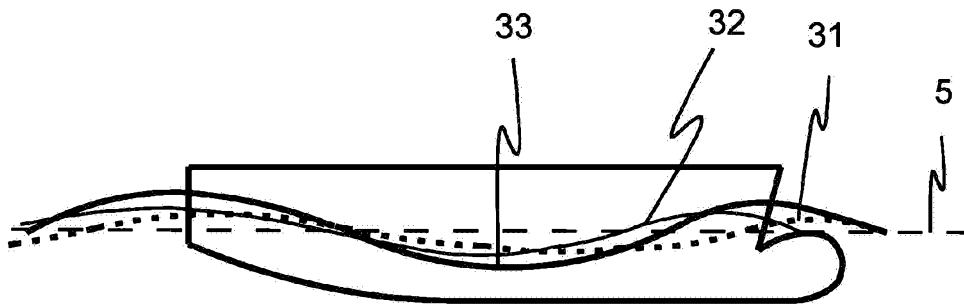

Figure 2



A



B

Figure 3

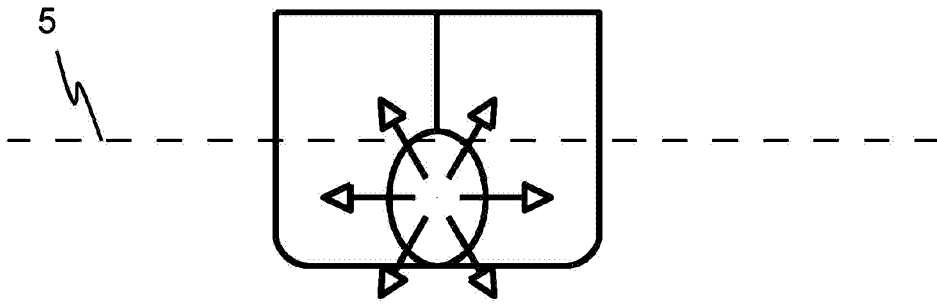

A

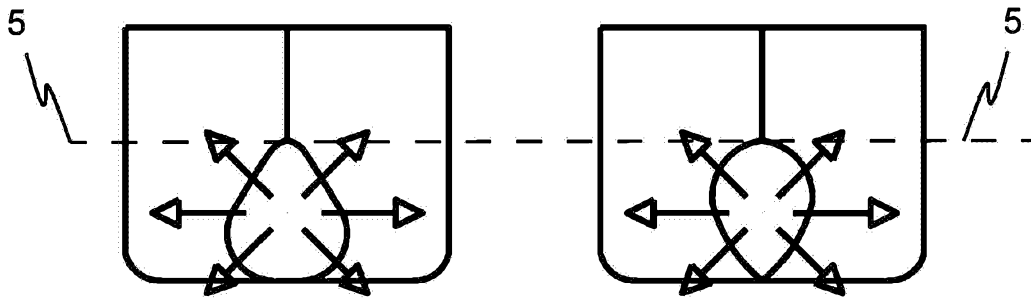

B

C

Figure 4

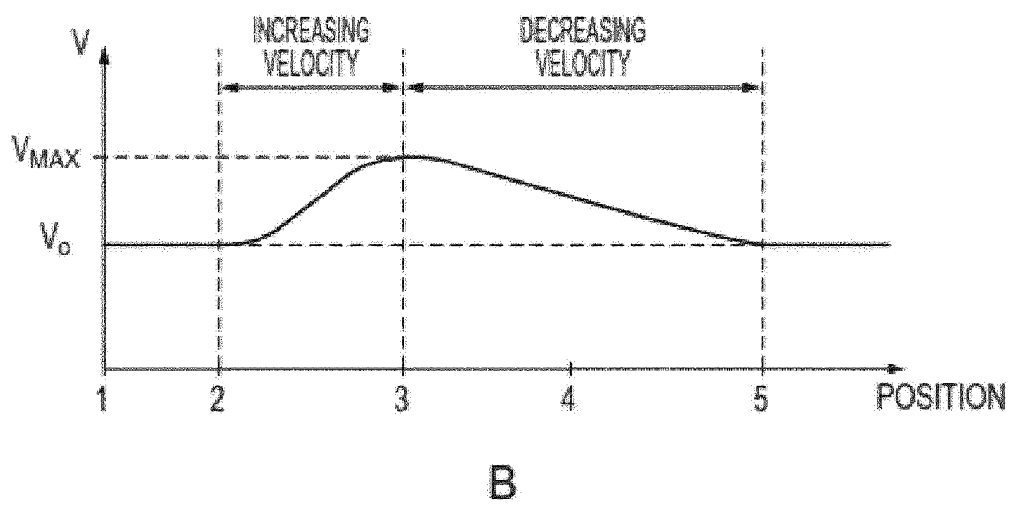
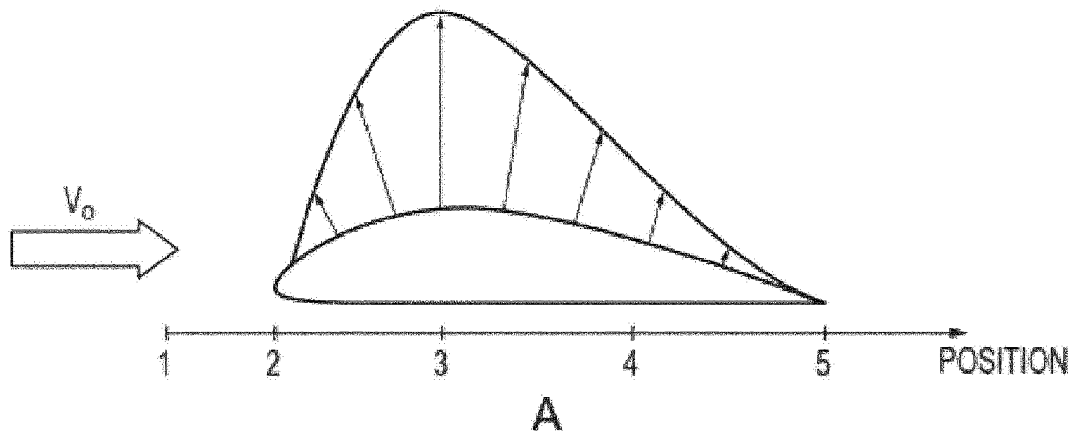

Figure 5

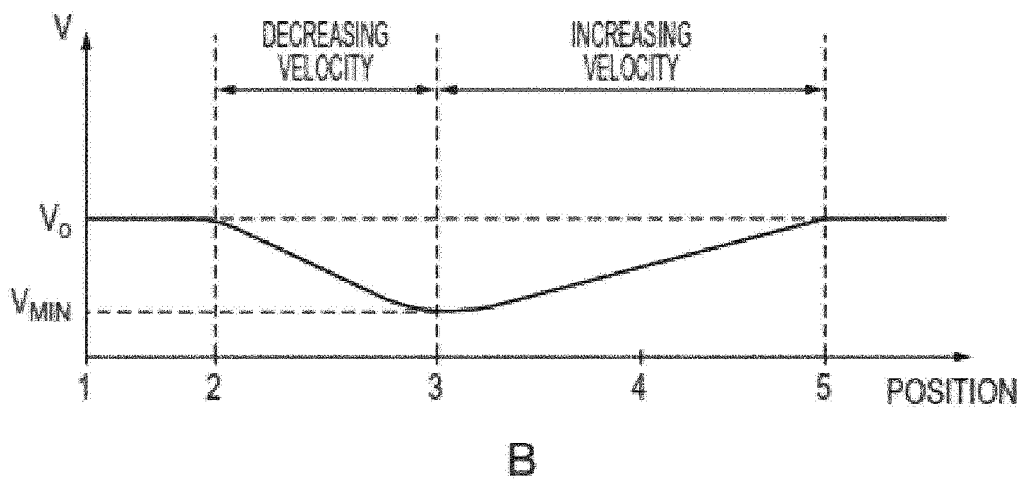
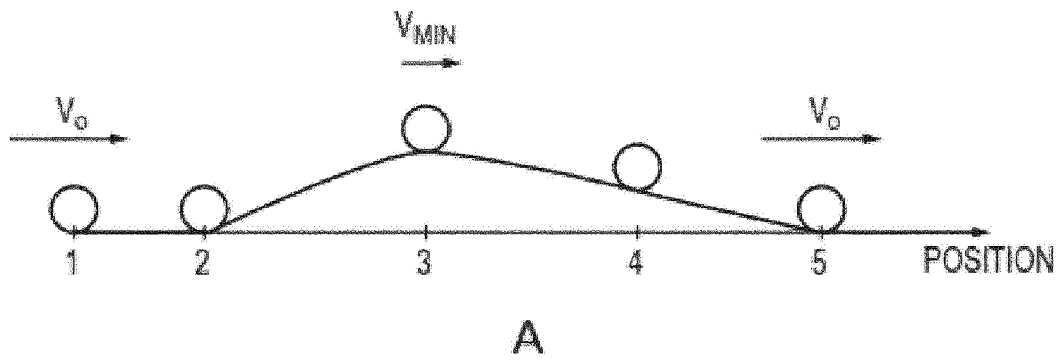

Figure 6

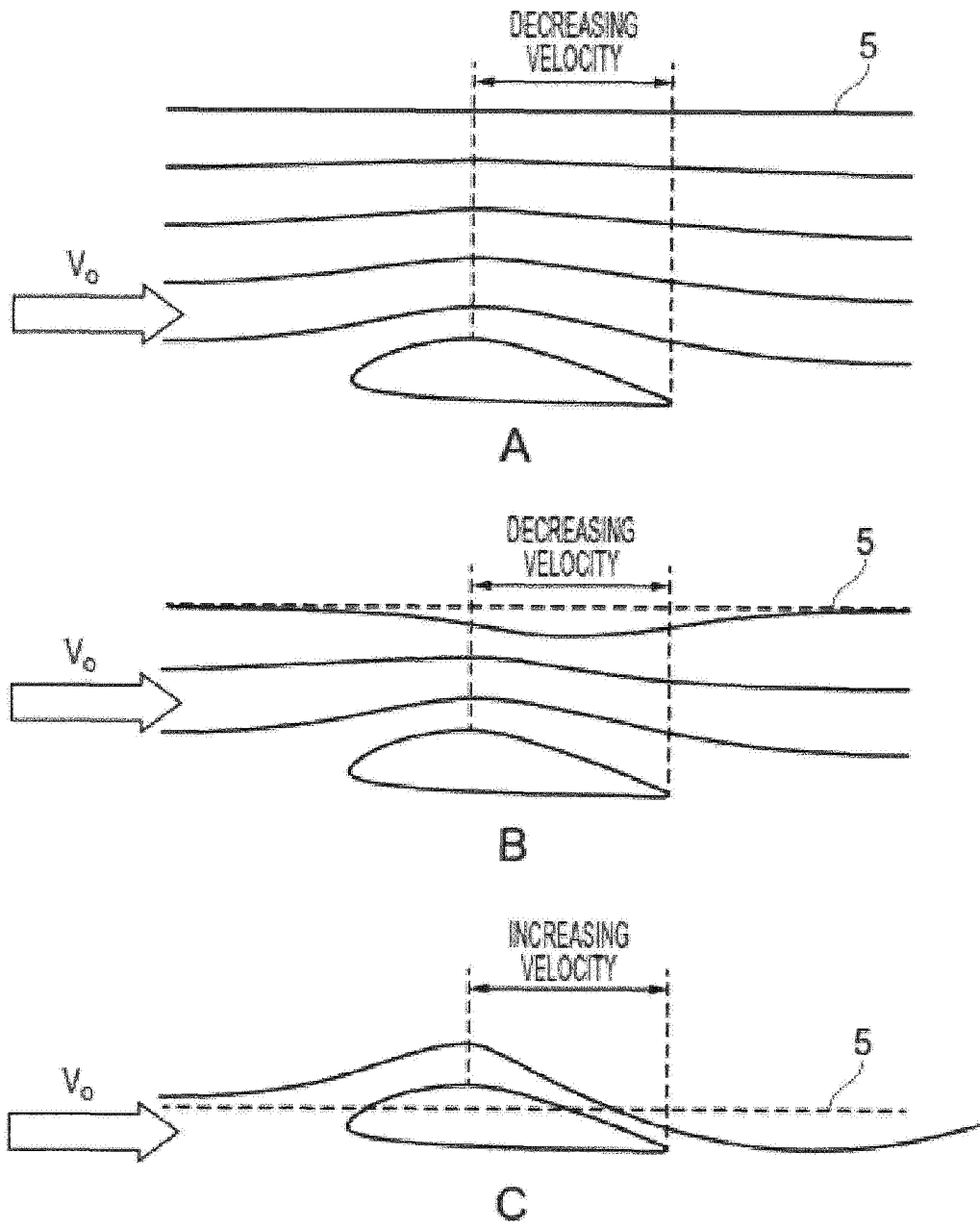

Figure 7

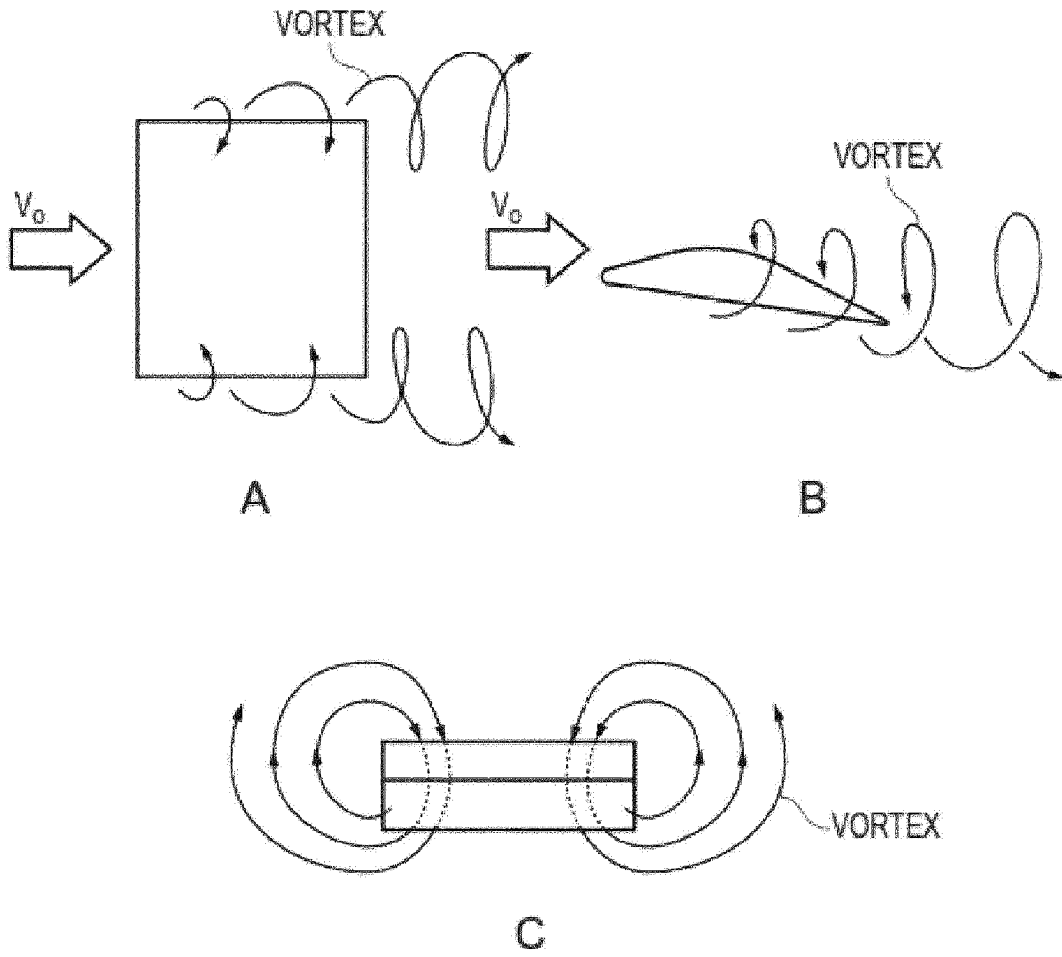
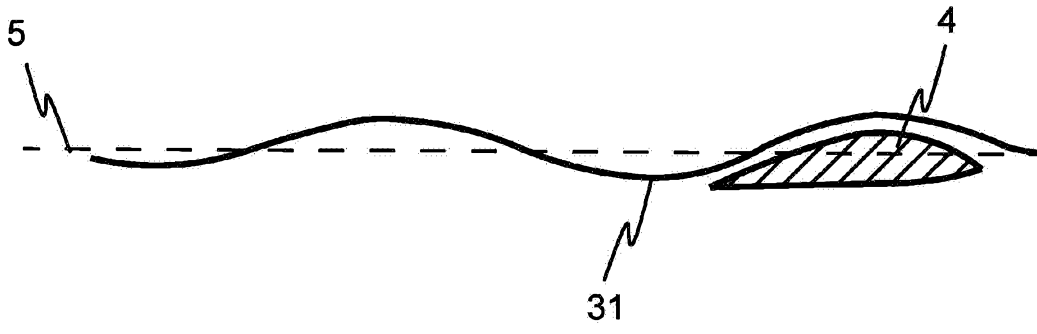
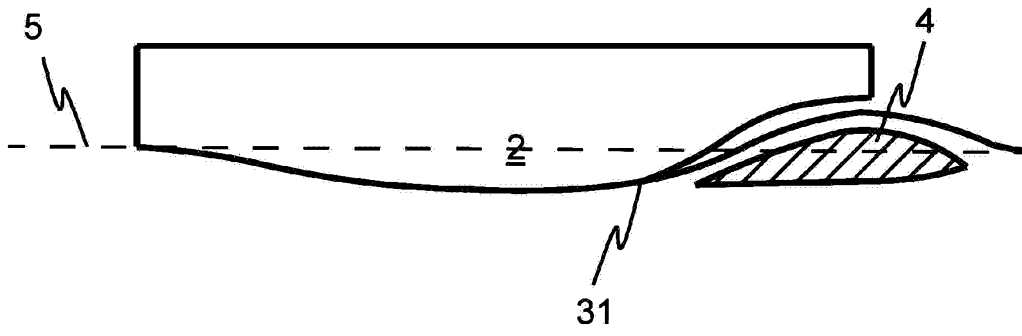

Figure 8



A



B

Figure 9

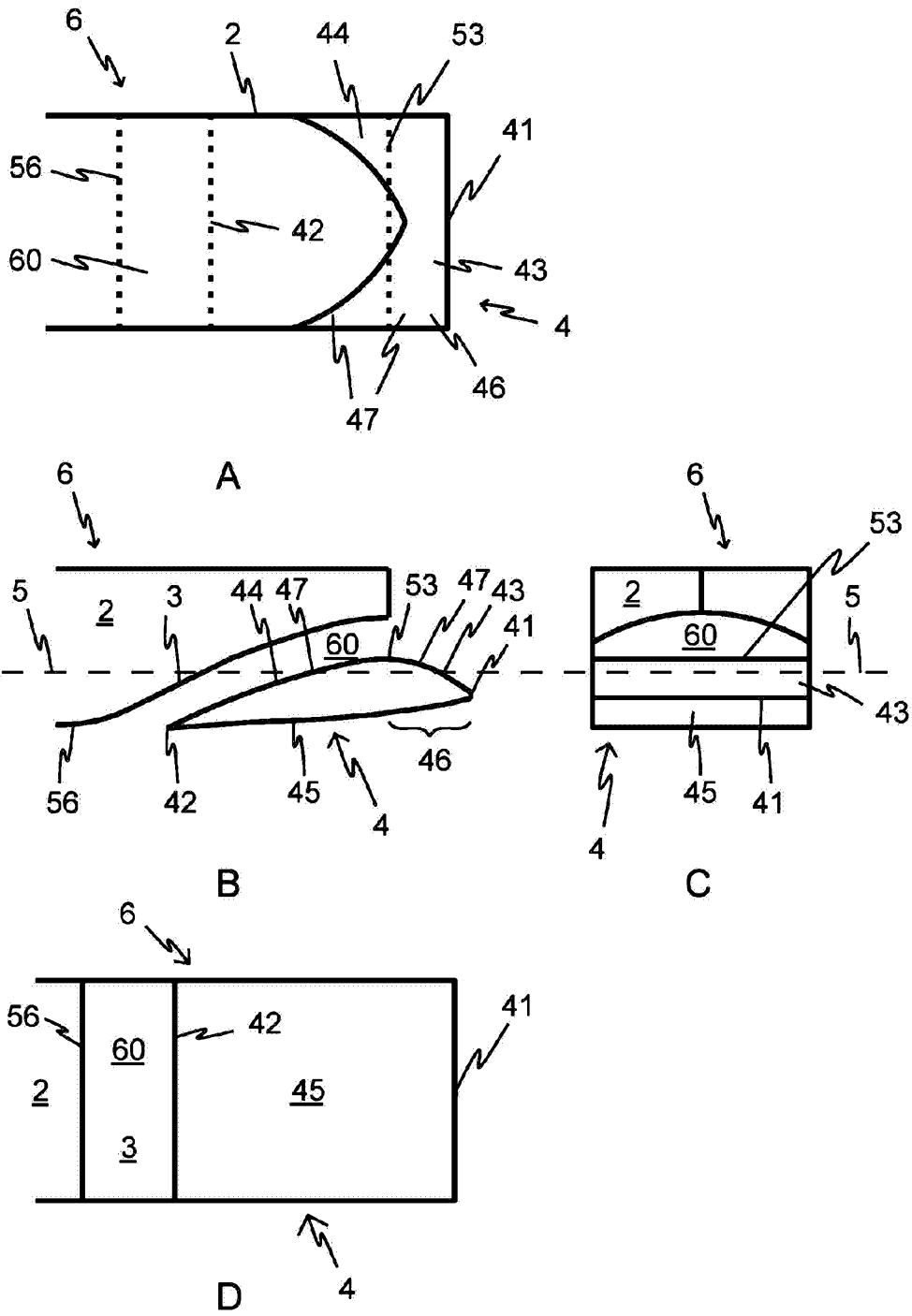

Figure 10

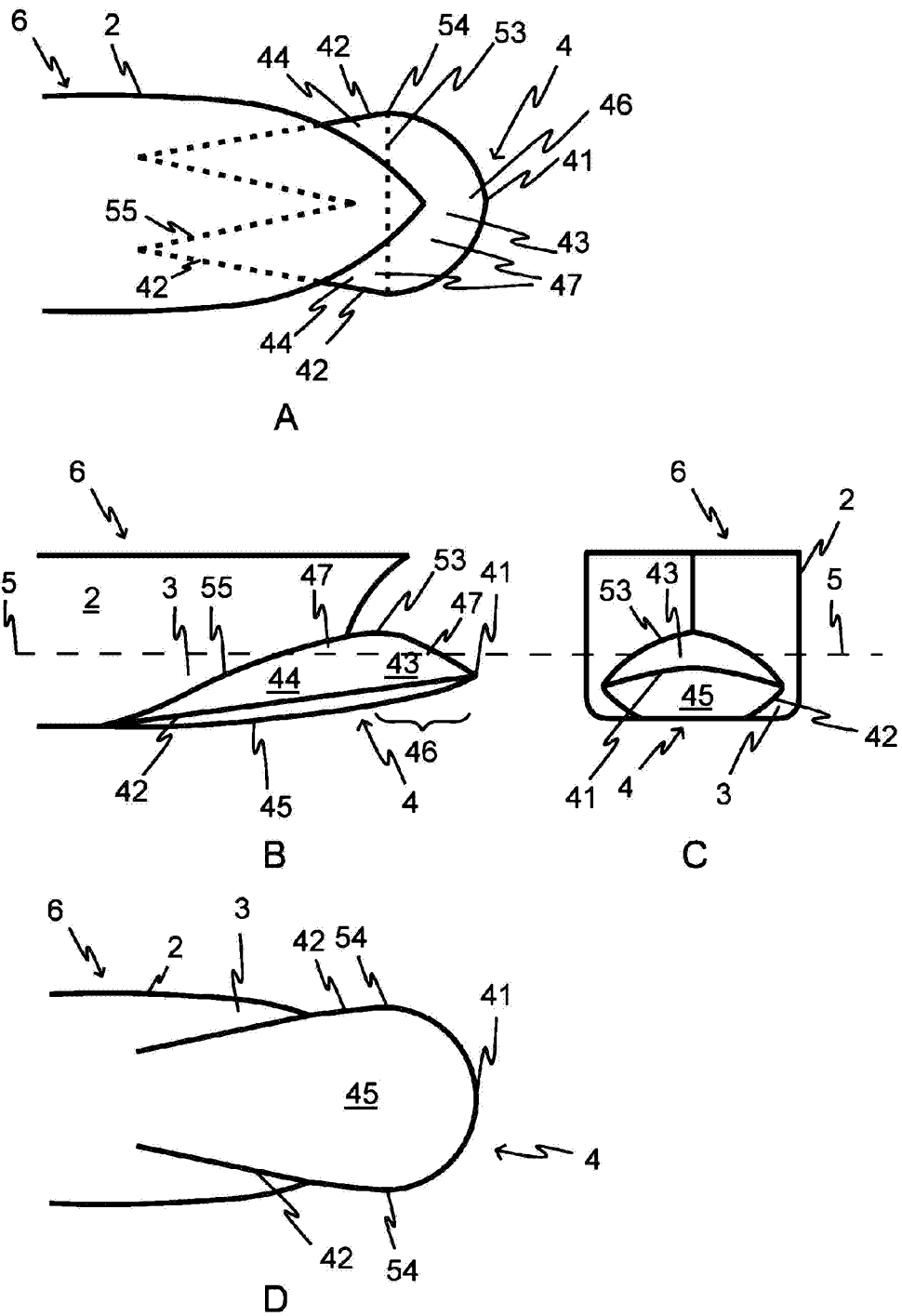

Figure 11

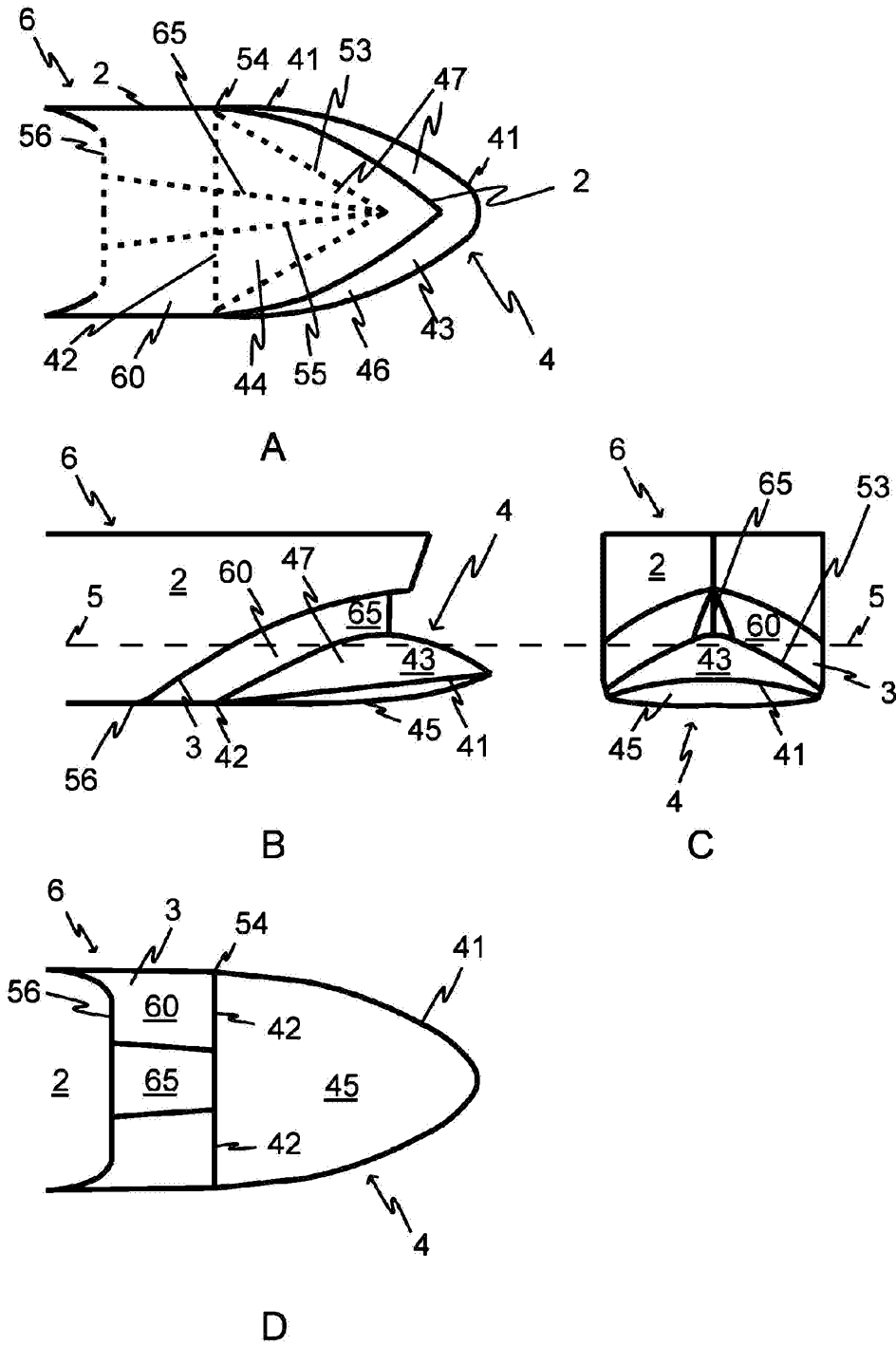

Figure 12

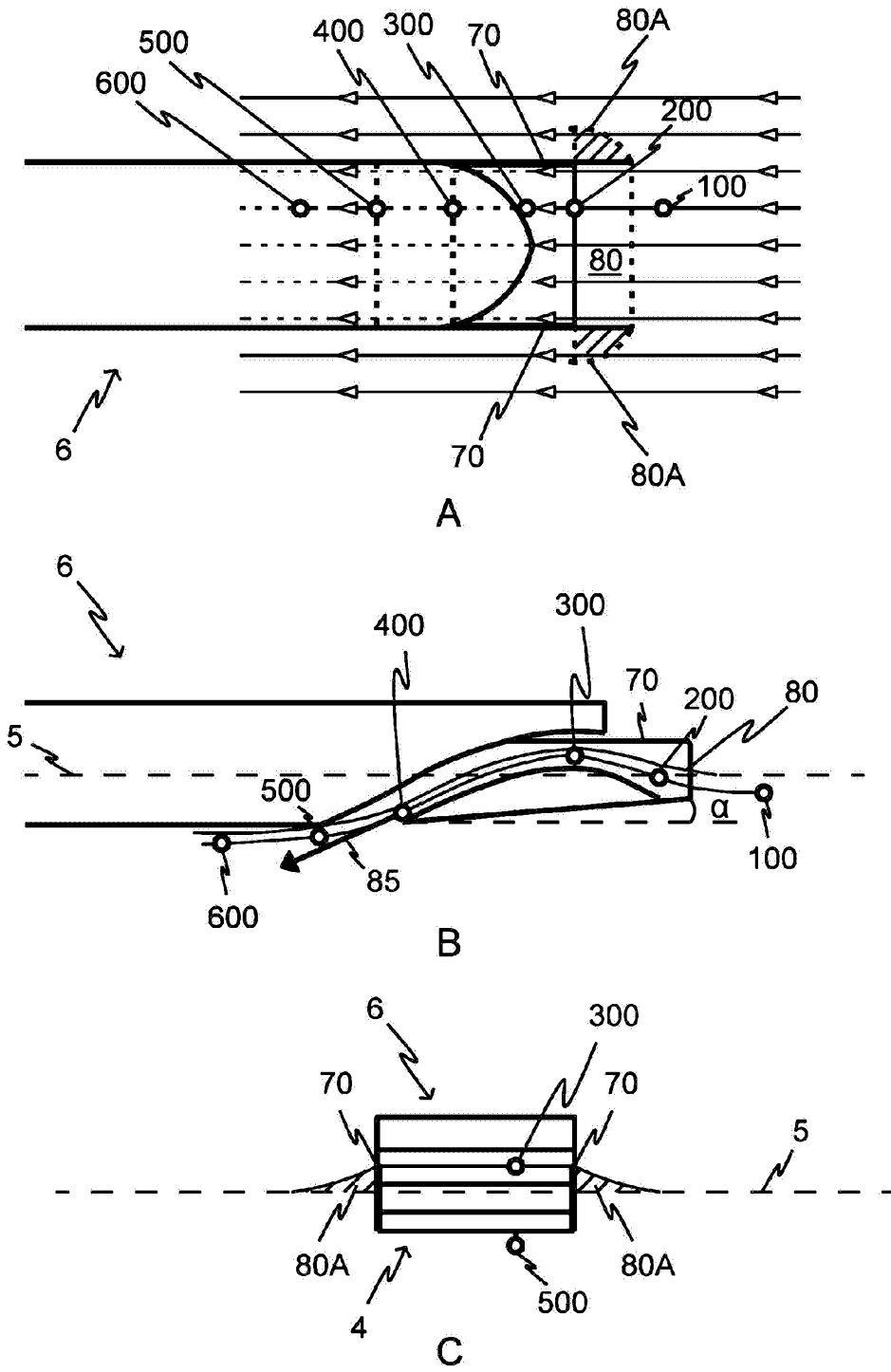

Figure 13

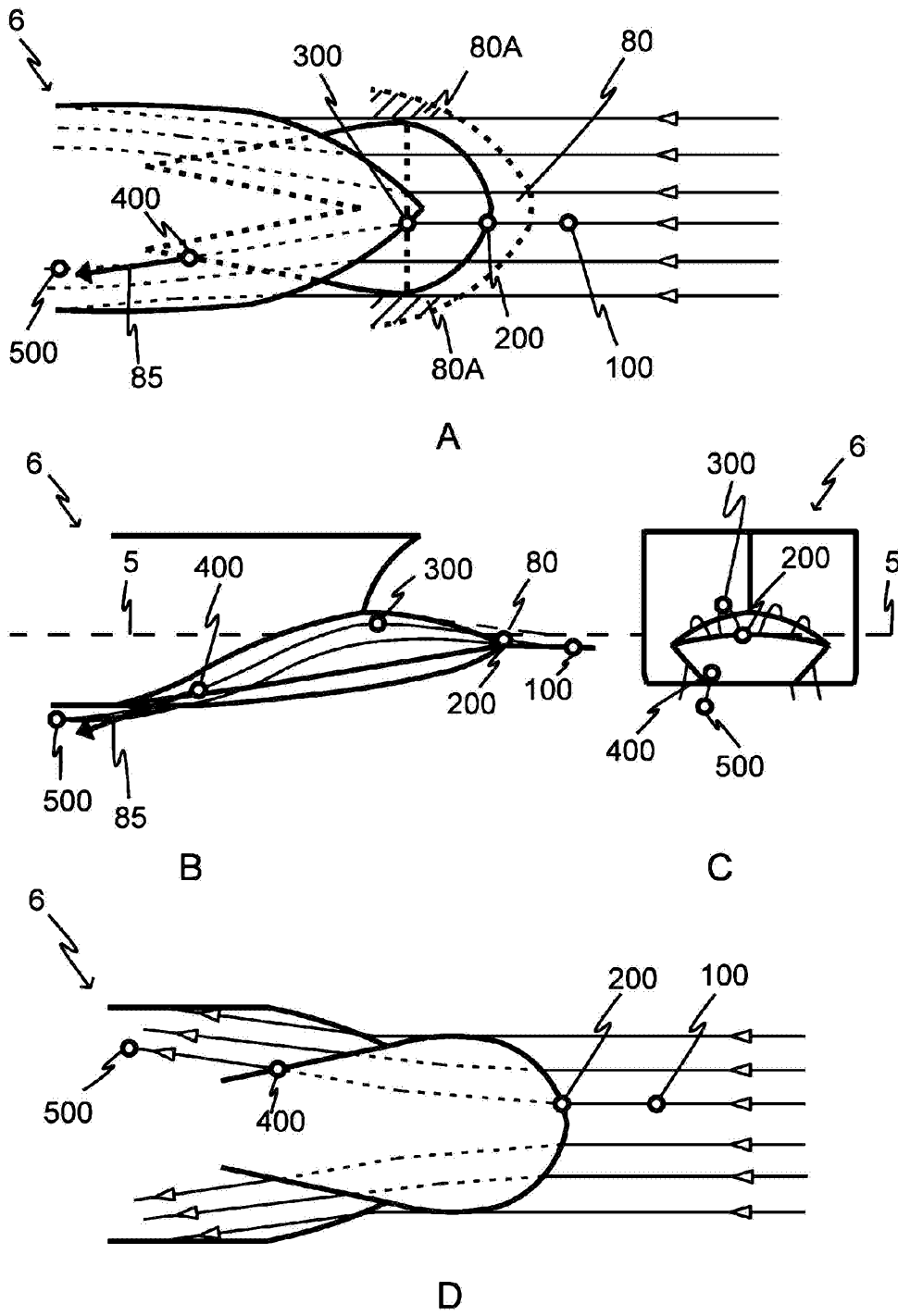

Figure 14

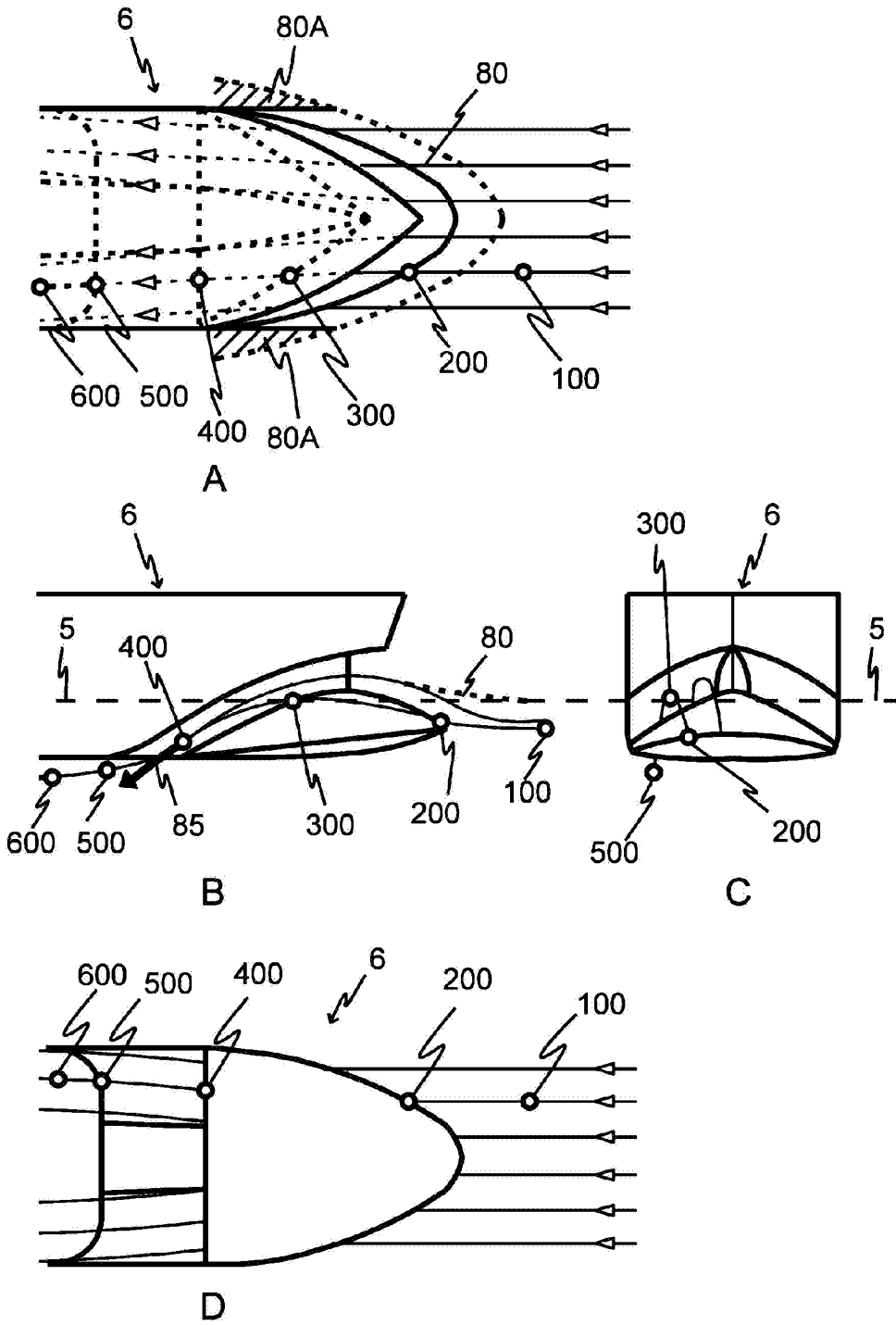

Figure 15

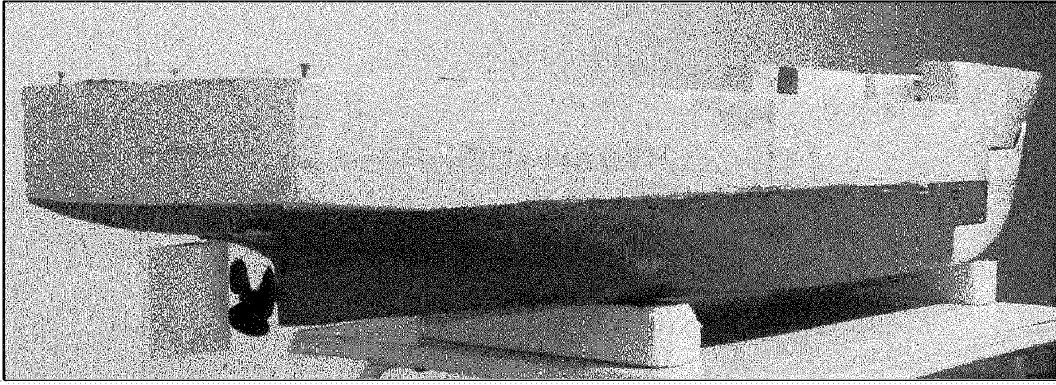

Figure 16A

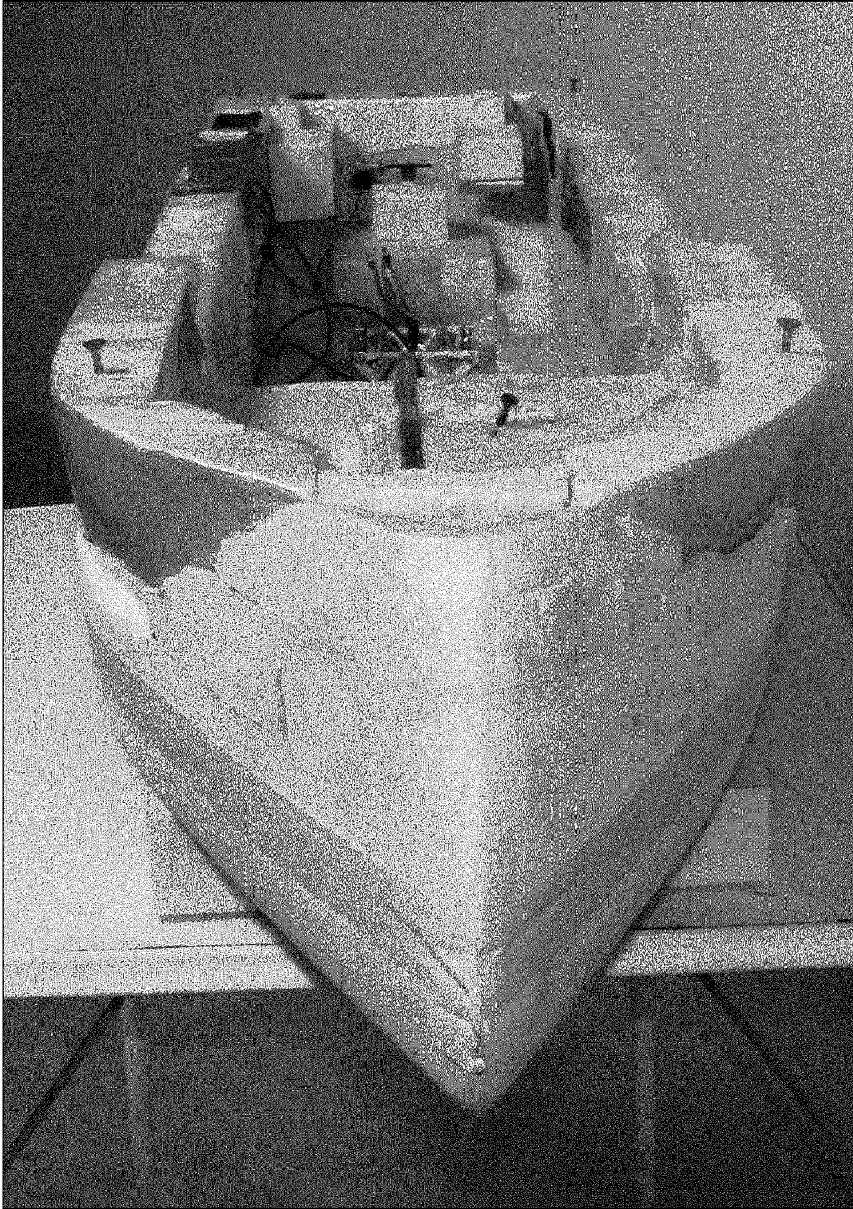

Figure 16B

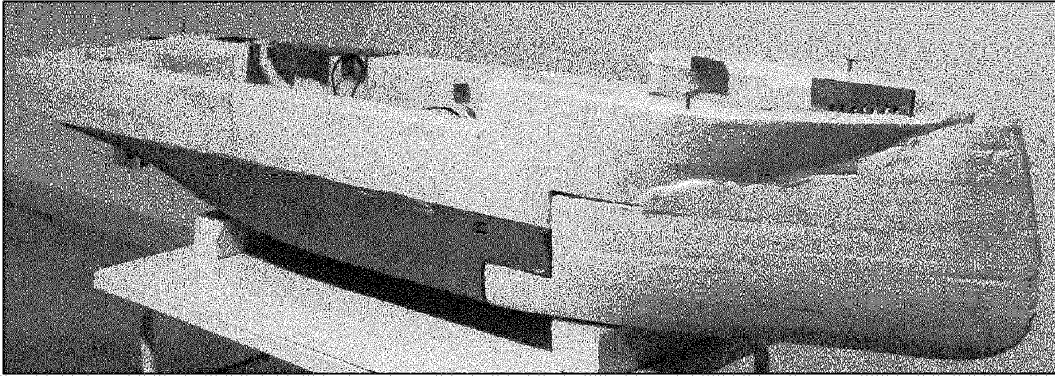

Figure 16C

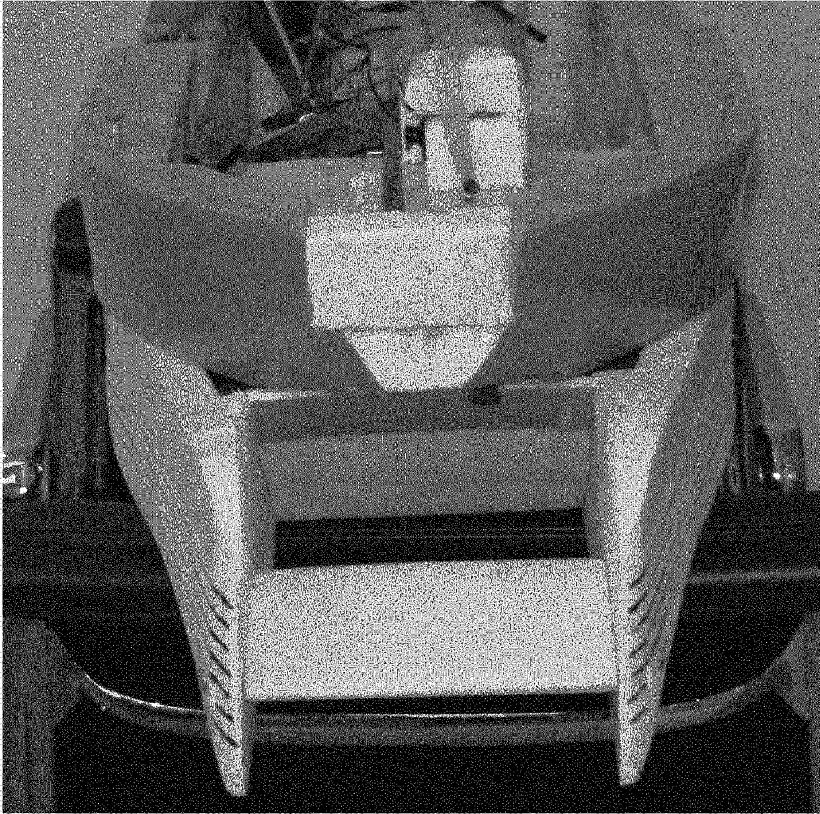

Figure 17A

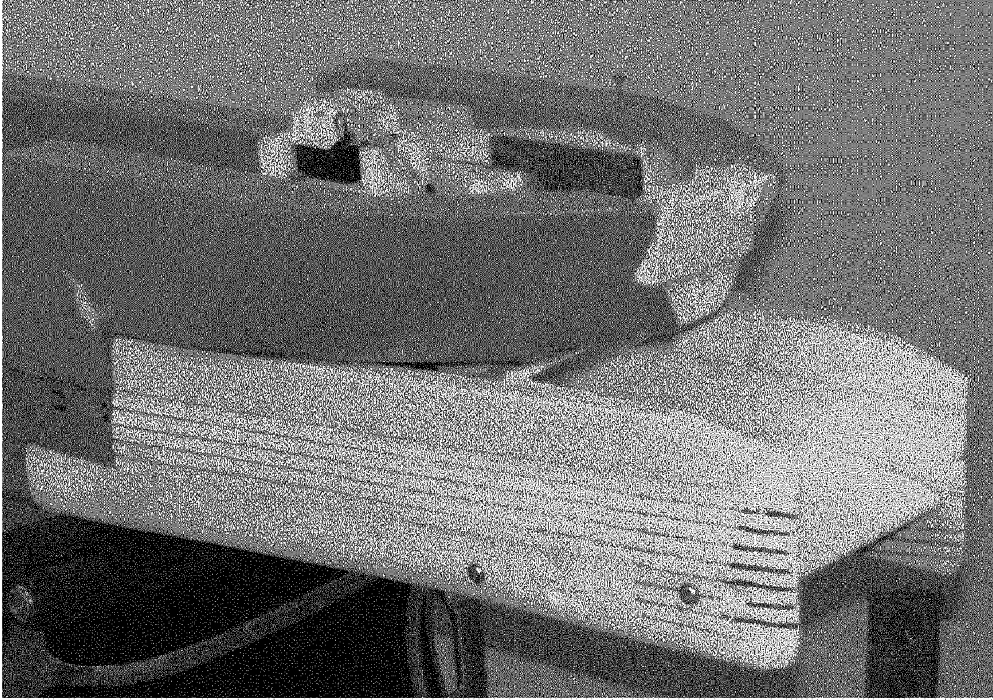

Figure 17B

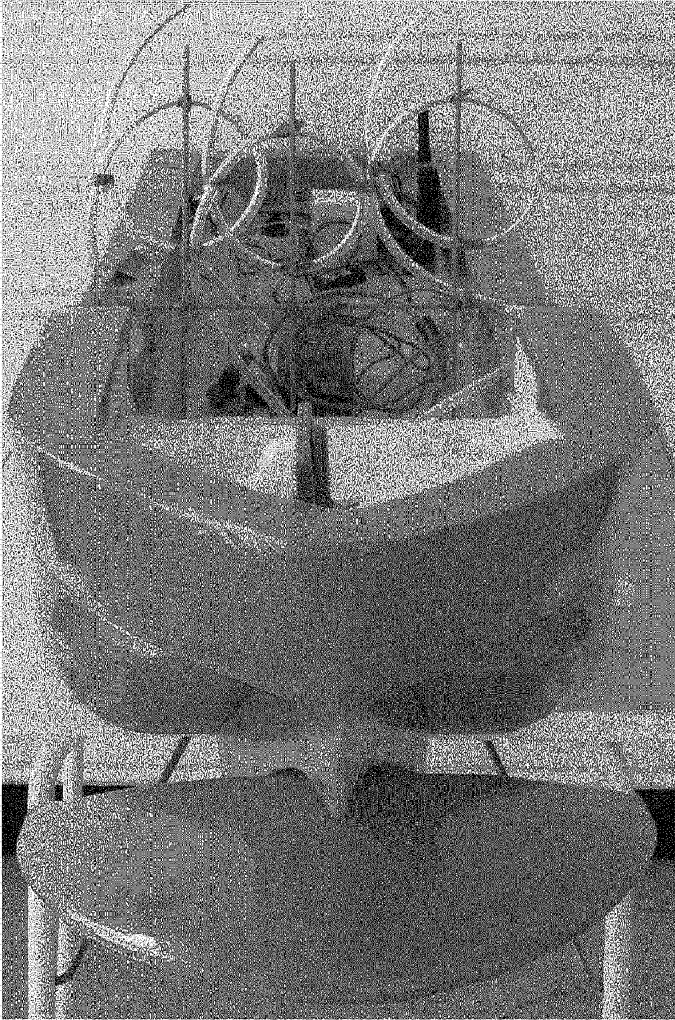

Figure 18A

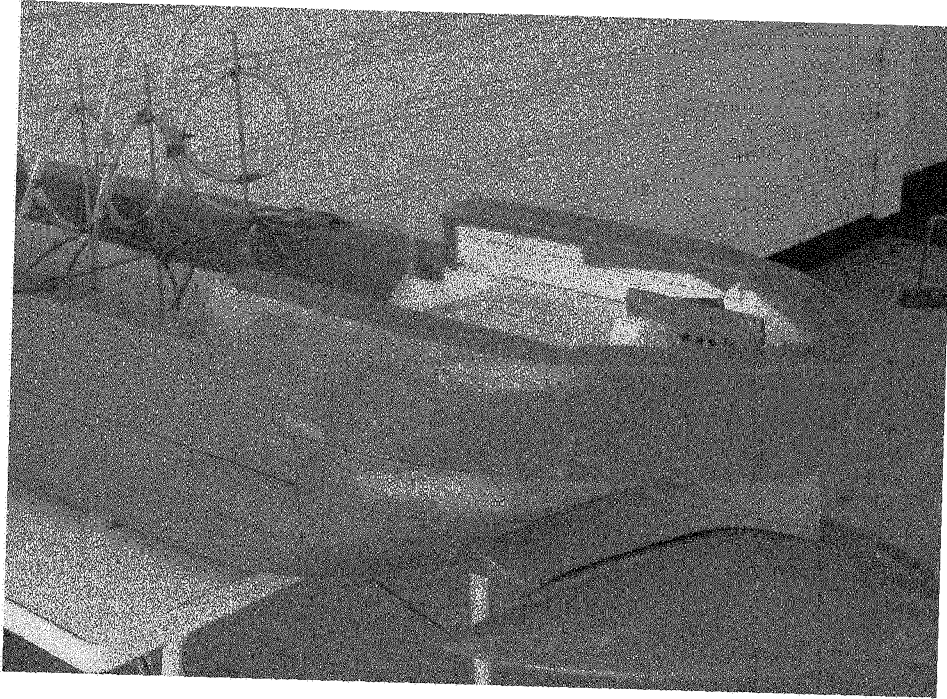

Figure 18B

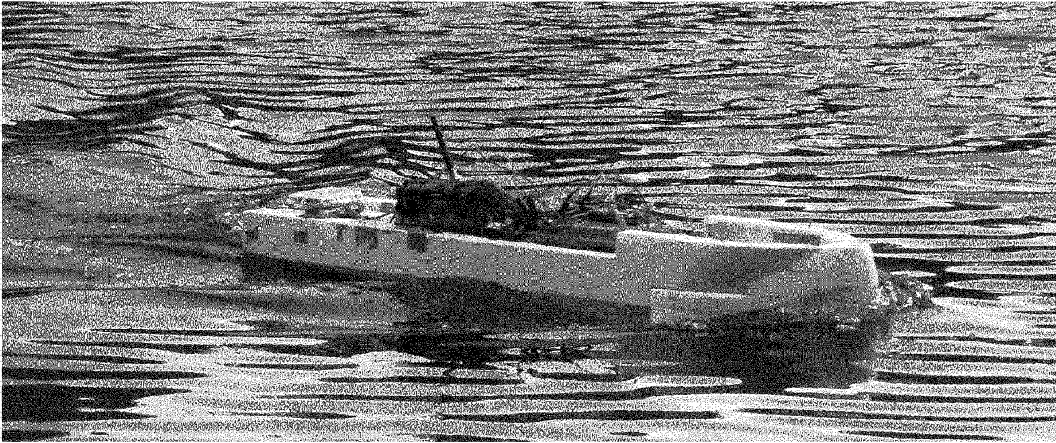

Figure 19A

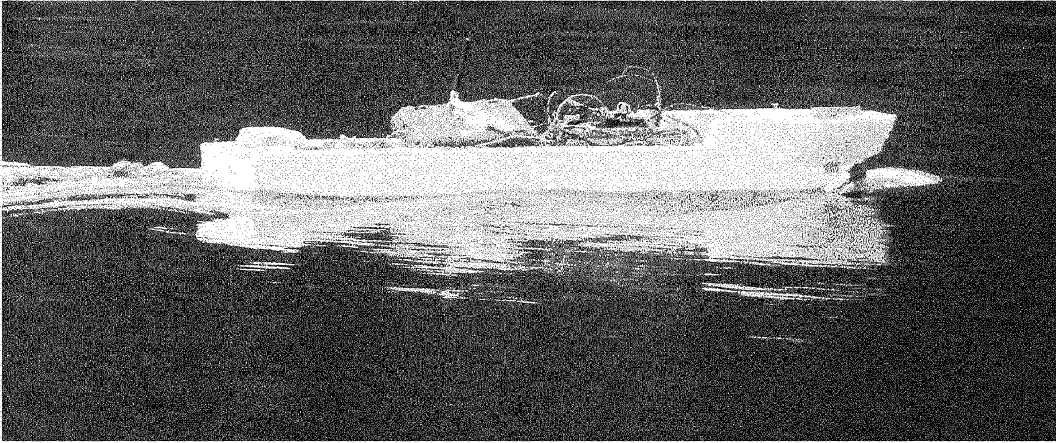

Figure 19B

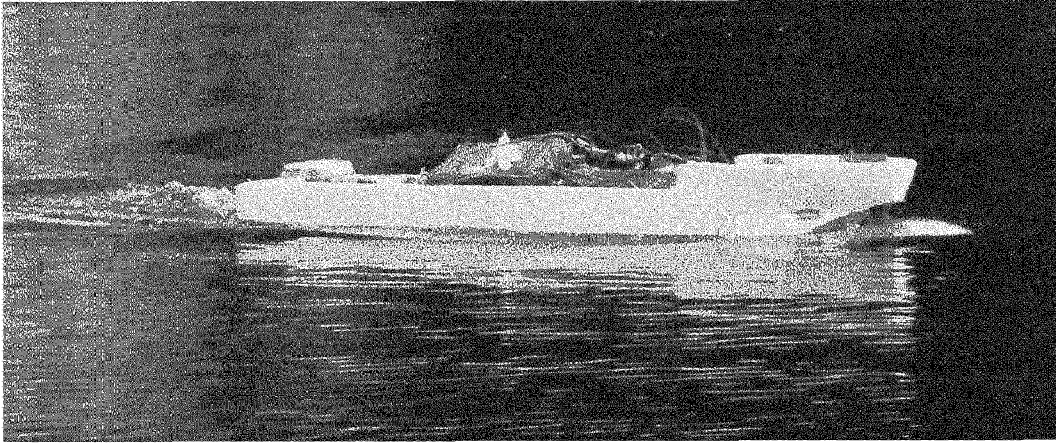

Figure 19C

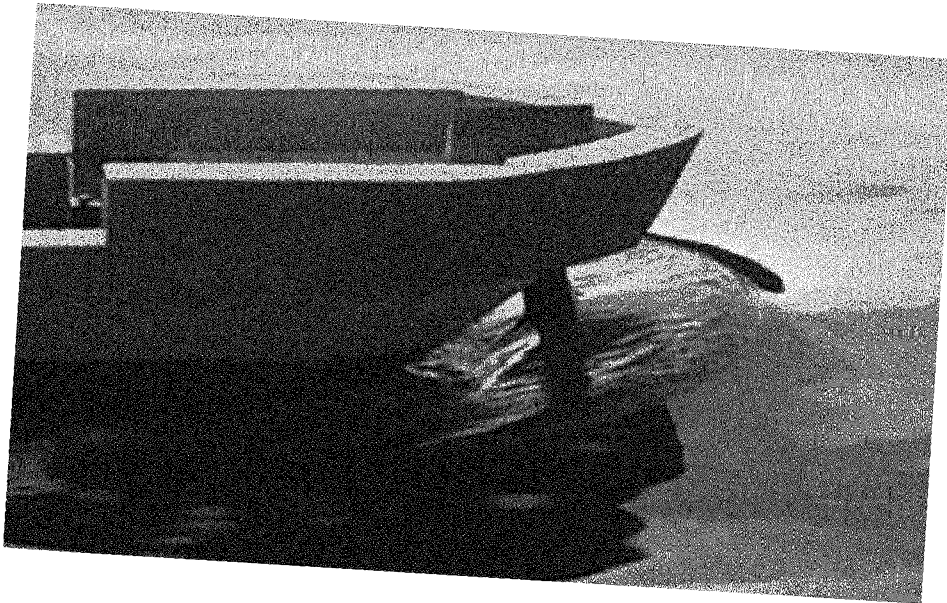

Figure 20A

DK/EP 3247620 T3

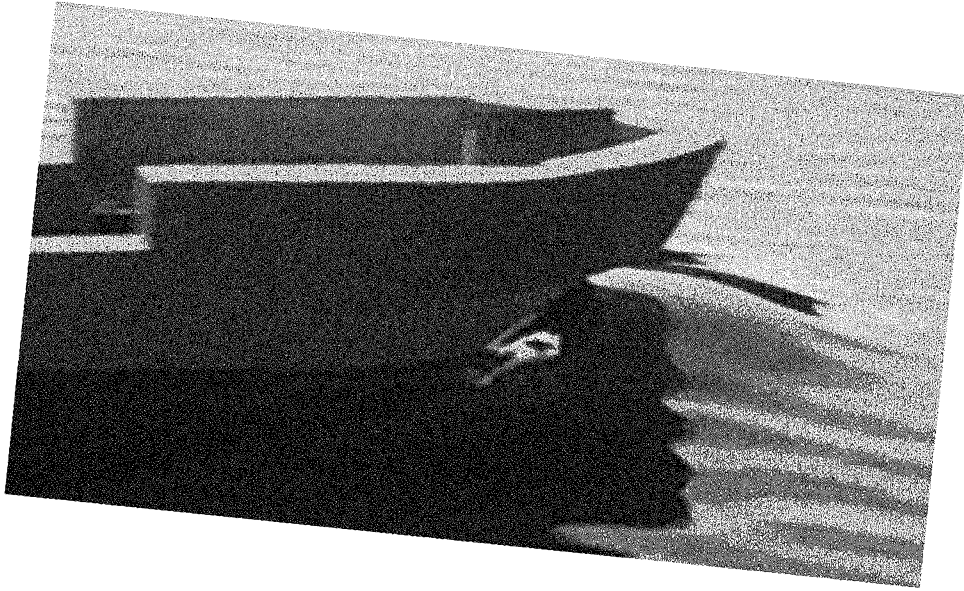

Figure 20B

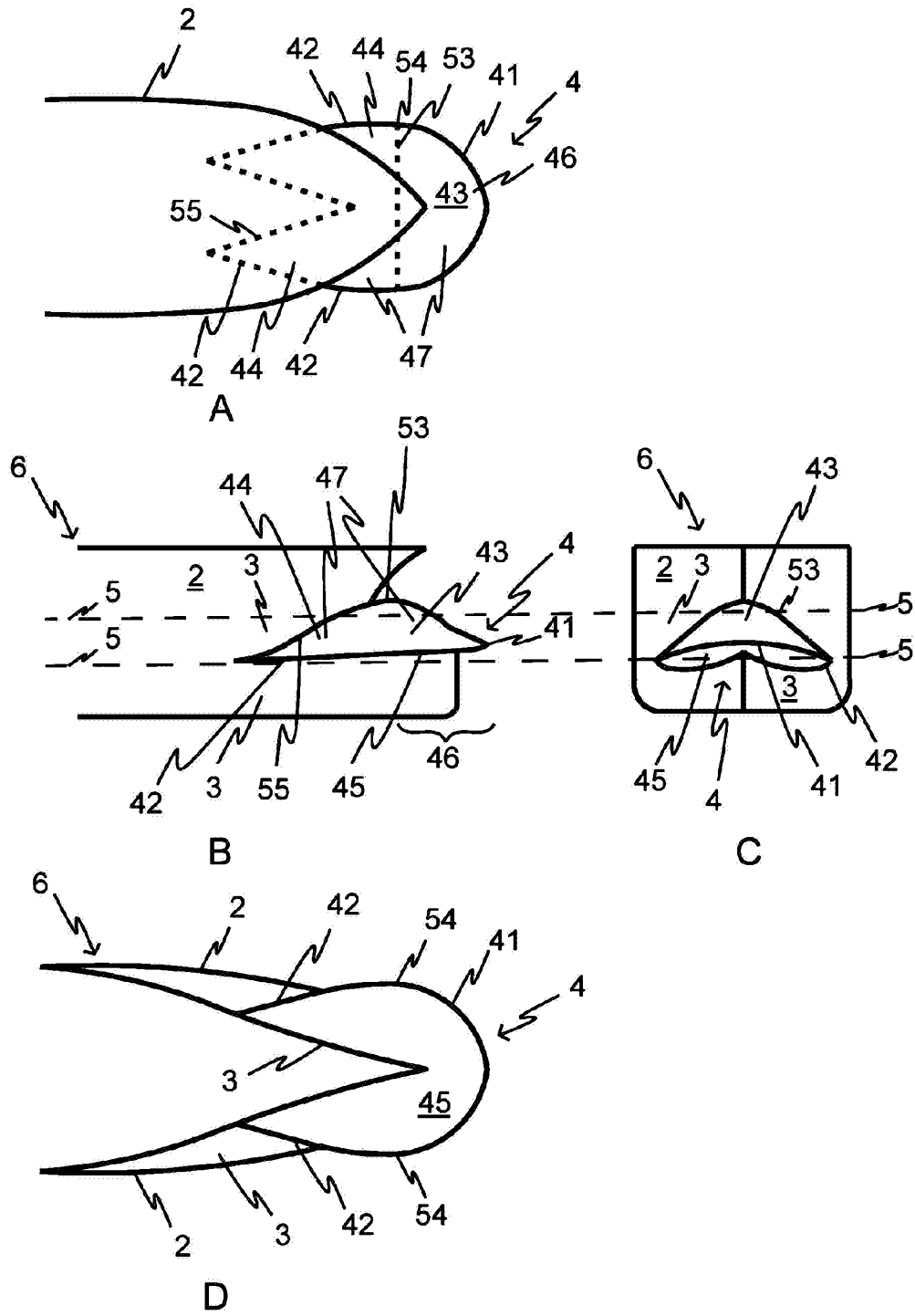

Figure 21

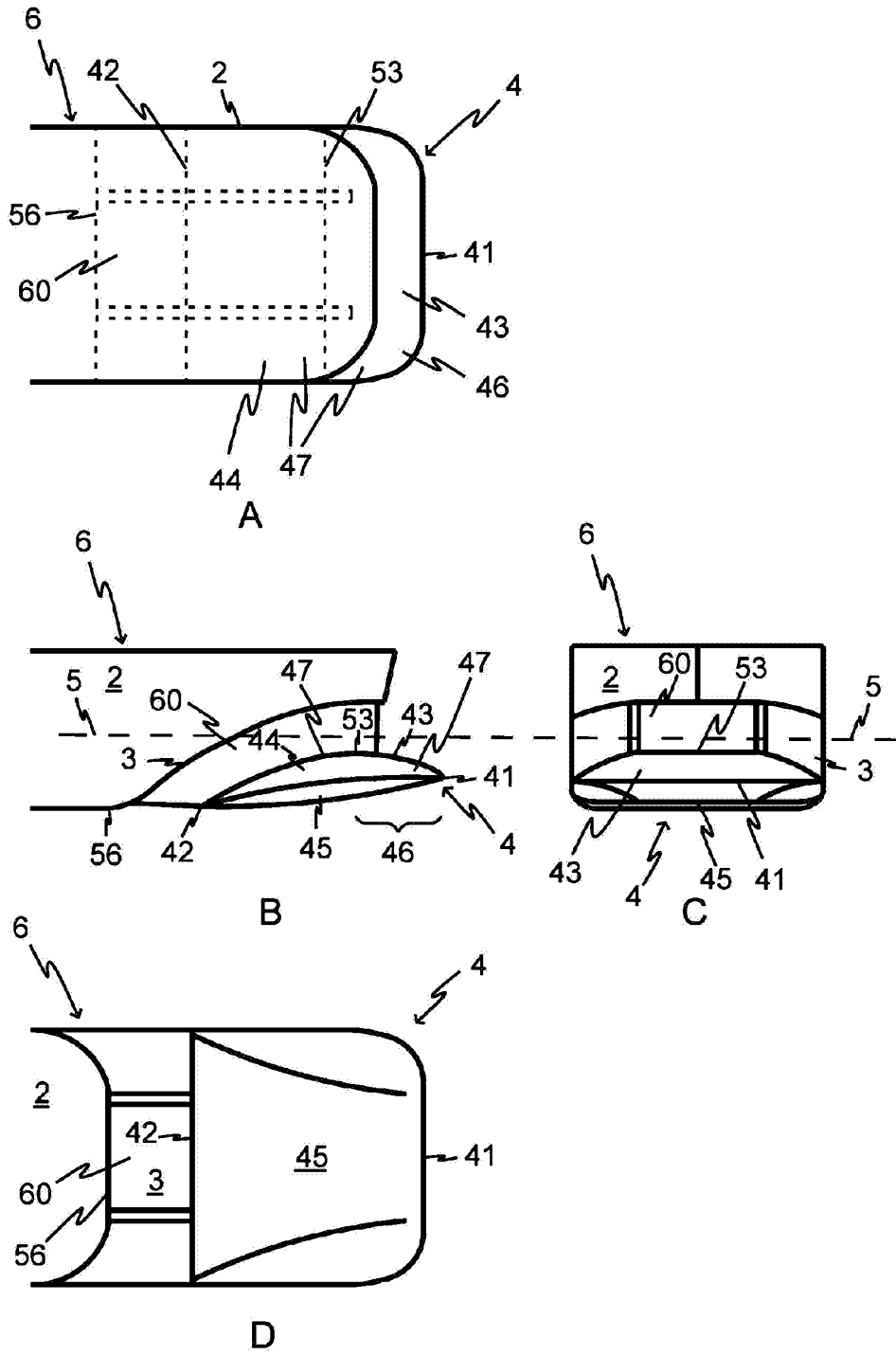

Figure 22

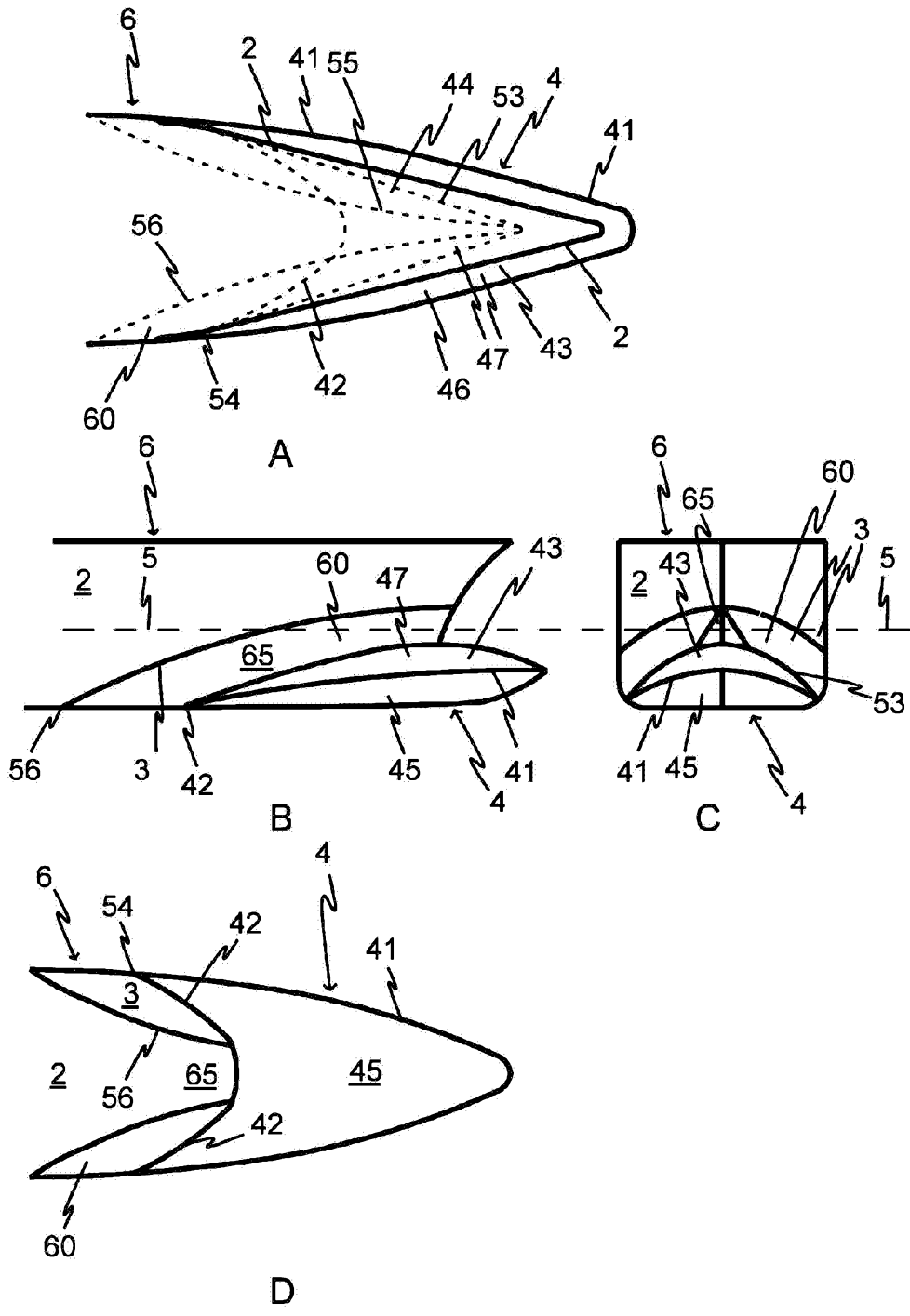

Figure 23

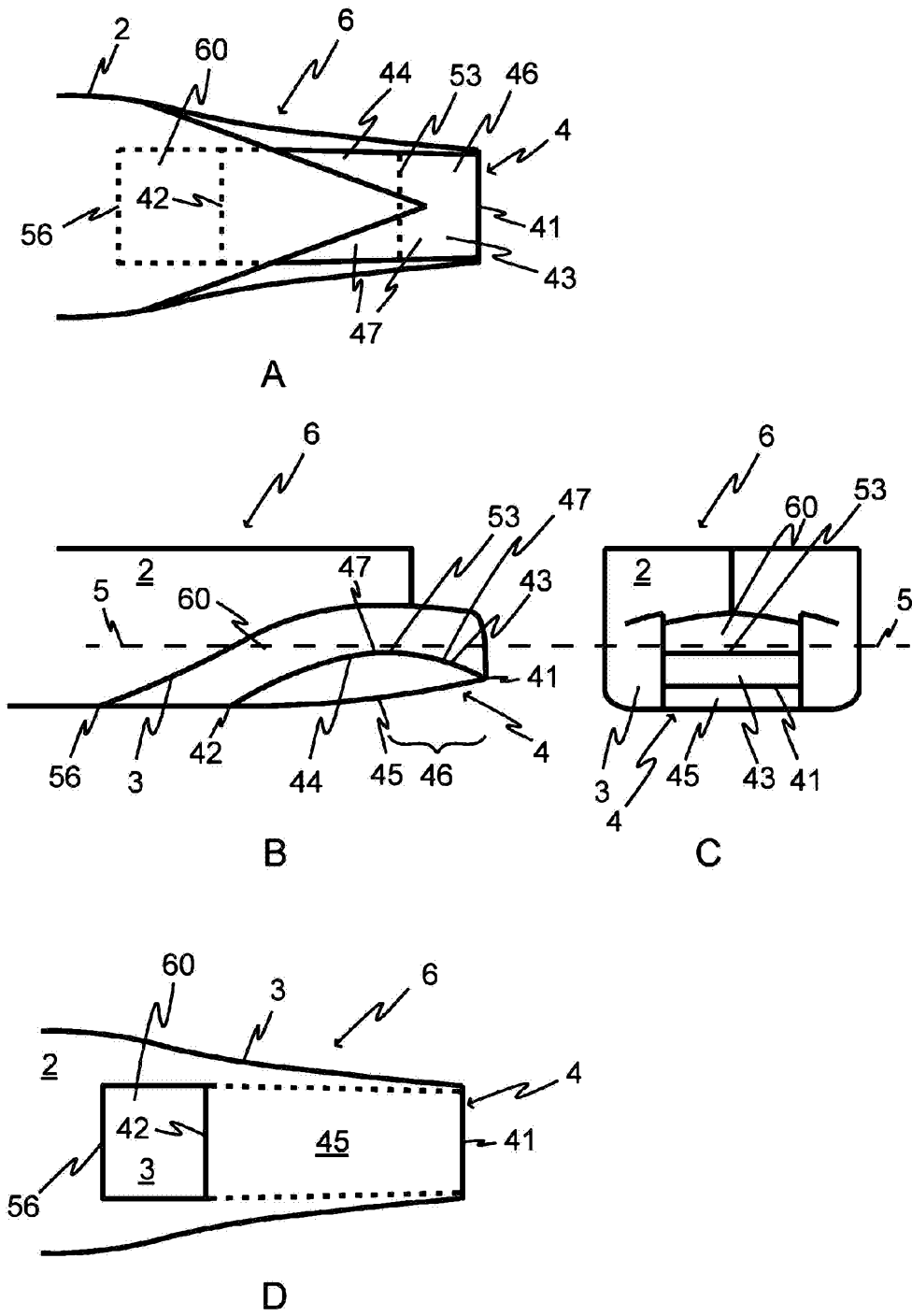
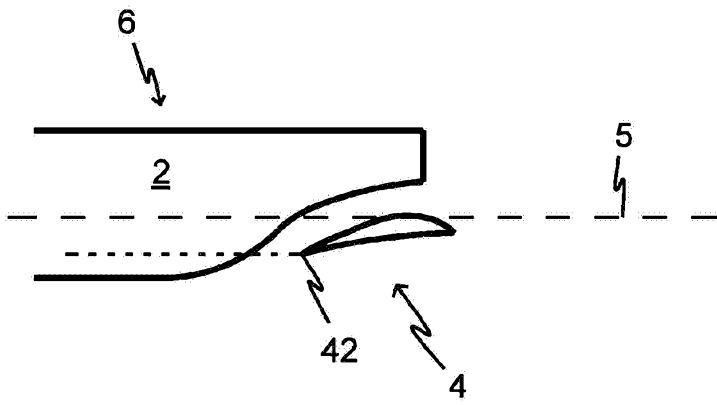
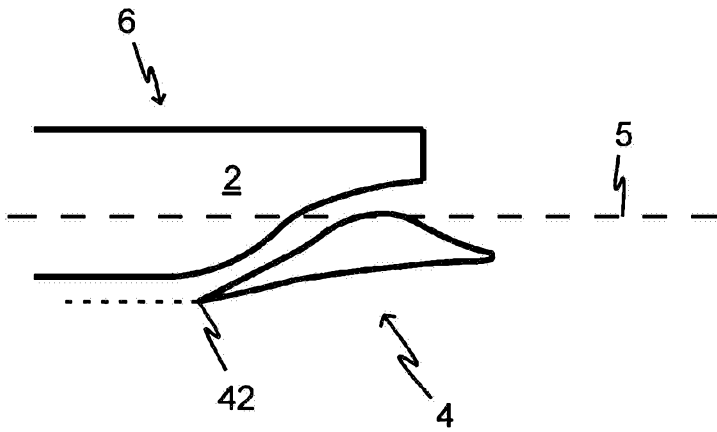

Figure 24



A



B

Figure 25

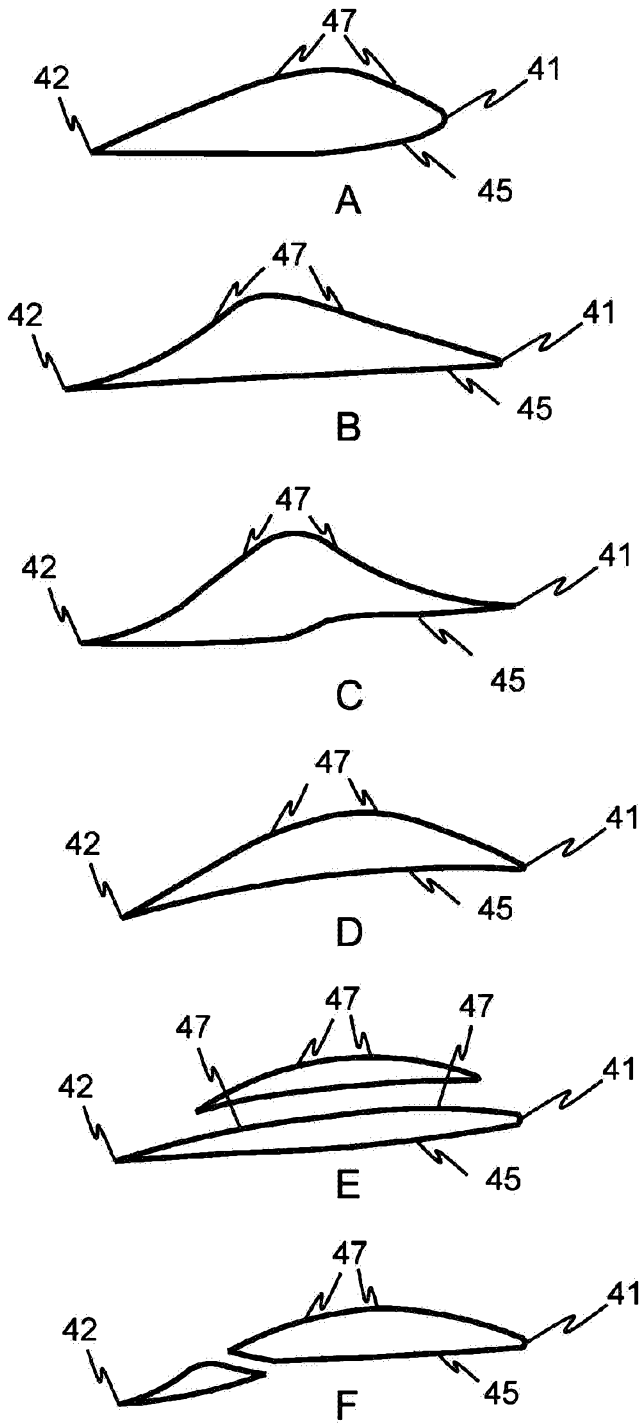

Figure 26

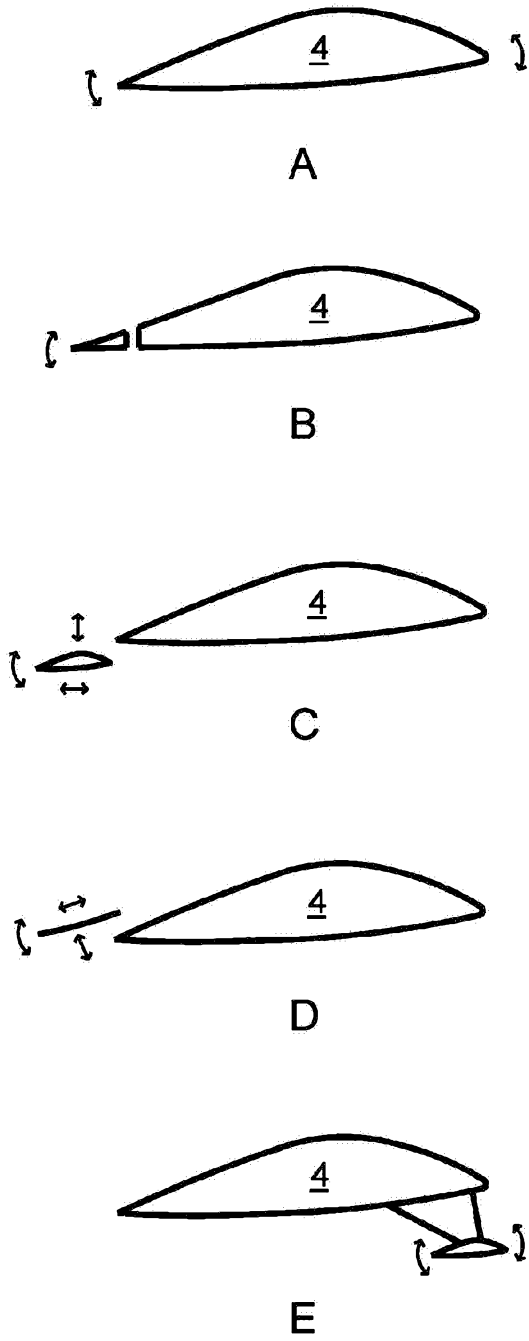

Figure 27

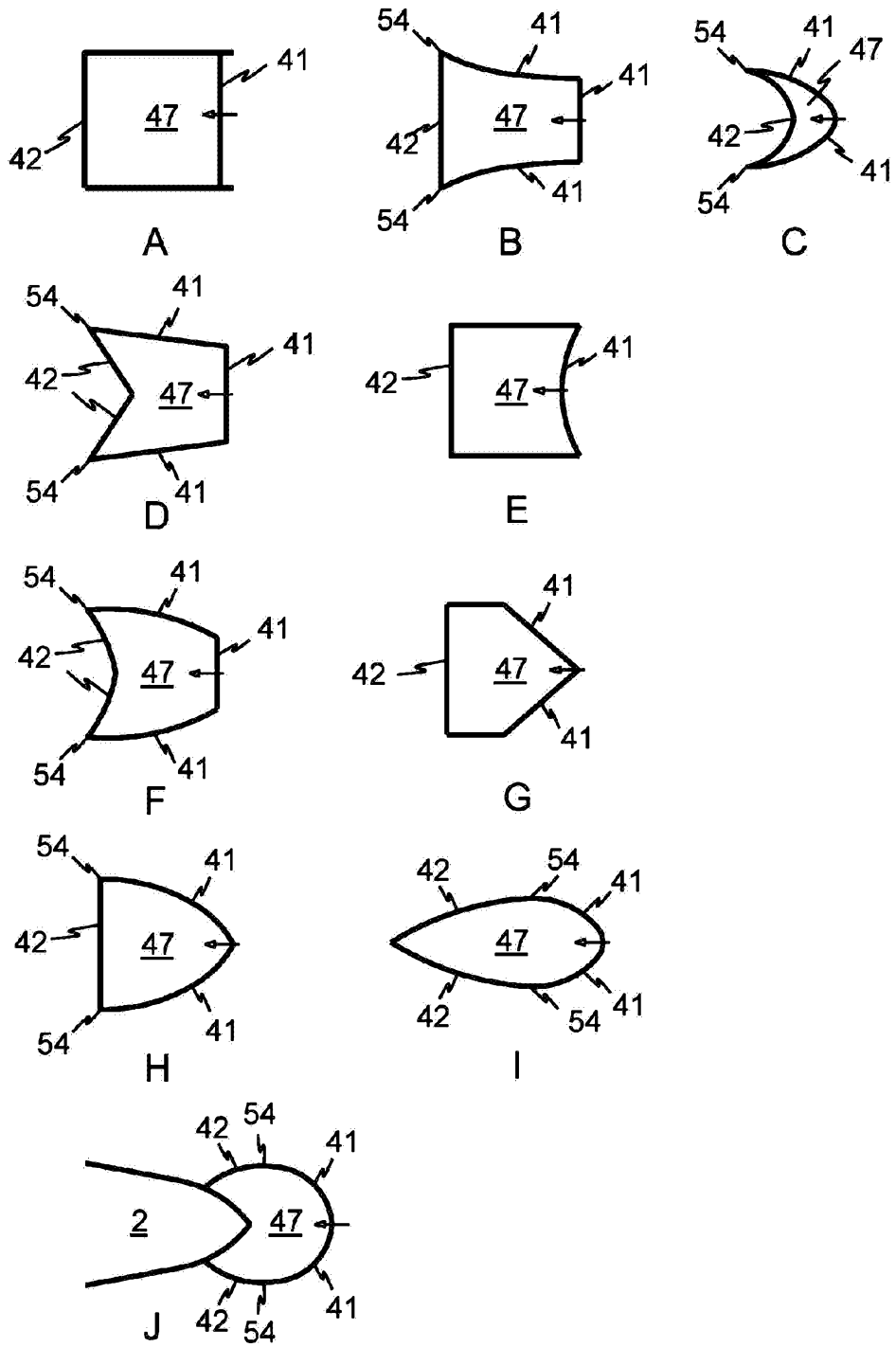

Figure 28