



- (51) International Patent Classification:
A61M 29/00 (2006.01)
- (21) International Application Number:
PCT/US2012/031899
- (22) International Filing Date:
2 April 2012 (02.04.2012)
- (25) Filing Language: English
- (26) Publication Language: English
- (30) Priority Data:
61/470,733 1 April 2011 (01.04.2011) US
- (71) Applicant (for all designated States except US): **CORNELL UNIVERSITY** [US/US]; 418 E. 71st Street, Suite 61, New York, NY 10021 (US).
- (72) Inventors; and
- (75) Inventors/Applicants (for US only): **RIINA, Howard** [US/US]; 125 Birchall Drive, Scarsdale, NY 10583 (US). **MILSOM, Jeffrey** [US/US]; 215 E. 68th Street, Apt. 32d, New York, NY 10021 (US). **COMHILL, J., Frederick** [CA/US]; 800 Fifth Avenue, Apt. 11b, New York, NY

10065 (US). **NGUYEN, Tuan Anh** [US/US]; 67 Willow Street, Woburn, MA 01801 (US). **SMITH, Kevin** [US/US]; 149 Frederick Street, Stamford, CT 06902 (US). **KEOUGH, Kevin** [US/US]; 16 Raven Road, Canton, MA 02021 (US). **ANDREWS, Robert** [US/US]; 5 Old Mill Road, Norfolk, MA 02056 (US).

(74) Agent: **PANDISCIO, Mark, J.**; Pandiscio & Pandiscio, 436 Boston Post Road, Weston, MA 02493 (US).

(81) Designated States (unless otherwise indicated, for every kind of national protection available): AE, AG, AL, AM, AO, AT, AU, AZ, BA, BB, BG, BH, BR, BW, BY, BZ, CA, CH, CL, CN, CO, CR, CU, CZ, DE, DK, DM, DO, DZ, EC, EE, EG, ES, FI, GB, GD, GE, GH, GM, GT, HN, HR, HU, ID, IL, IN, IS, JP, KE, KG, KM, KN, KP, KR, KZ, LA, LC, LK, LR, LS, LT, LU, LY, MA, MD, ME, MG, MK, MN, MW, MX, MY, MZ, NA, NG, NI, NO, NZ, OM, PE, PG, PH, PL, PT, QA, RO, RS, RU, RW, SC, SD, SE, SG, SK, SL, SM, ST, SV, SY, TH, TJ, TM, TN, TR, TT, TZ, UA, UG, US, UZ, VC, VN, ZA, ZM, ZW.

(84) Designated States (unless otherwise indicated, for every kind of regional protection available): ARIPO (BW, GH,

[Continued on next page]

(54) Title: METHOD AND APPARATUS FOR RESTRICTING FLOW THROUGH AN OPENING IN THE SIDE WALL OF A BODY LUMEN, AND/OR FOR REINFORCING A WEAKNESS IN THE SIDE WALL OF A BODY LUMEN, WHILE STILL MAINTAINING SUBSTANTIALLY NORMAL FLOW THROUGH THE BODY LUMEN

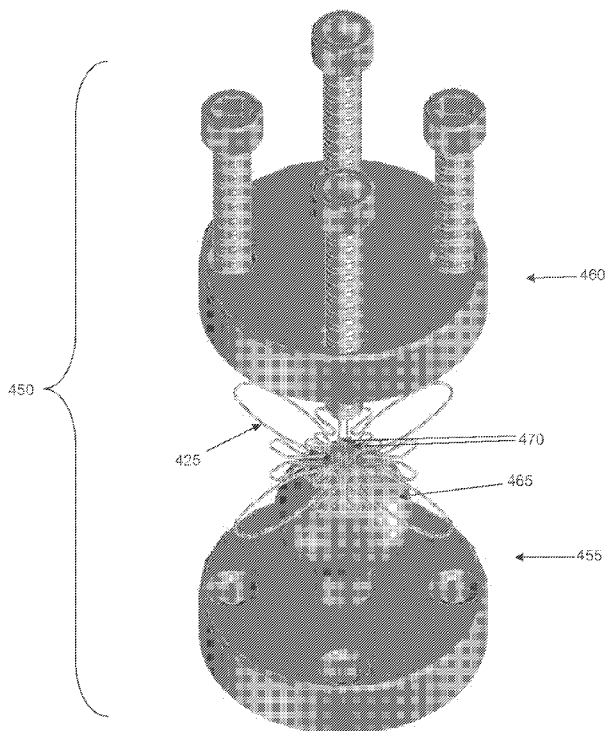

FIG. 120

(57) Abstract: A method for making a device for causing thrombosis of an aneurysm, wherein said device comprises a single elastic filament configurable between (i) an elongated, substantially linear configuration, and (ii) a longitudinally-contracted, substantially three-dimensional configuration, said method comprising: providing a sheet of shape memory material; producing a single filament, two-dimensional interim structure from said sheet of shape memory material; mounting said single filament, two-dimensional interim structure to a fixture so that said single filament, two-dimensional interim structure is transformed into said longitudinally-contracted, substantially three-dimensional configuration; and heat treating said single filament, two-dimensional interim structure while it is mounted to said fixture so as to produce said device in its longitudinally-contracted, substantially three-dimensional configuration.



GM, KE, LR, LS, MW, MZ, NA, RW, SD, SL, SZ, TZ, UG, ZM, ZW), Eurasian (AM, AZ, BY, KG, KZ, MD, RU, TJ, TM), European (AL, AT, BE, BG, CH, CY, CZ, DE, DK, EE, ES, FI, FR, GB, GR, HR, HU, IE, IS, IT, LT, LU, LV, MC, MK, MT, NL, NO, PL, PT, RO, RS, SE, SI, SK, SM, TR), OAPI (BF, BJ, CF, CG, CI, CM, GA, GN, GQ, GW, ML, MR, NE, SN, TD, TG).

Published:

— *without international search report and to be republished upon receipt of that report (Rule 48.2(g))*

METHOD AND APPARATUS FOR RESTRICTING FLOW THROUGH AN
OPENING IN THE SIDE WALL OF A BODY LUMEN, AND/OR FOR
REINFORCING A WEAKNESS IN THE SIDE WALL OF A BODY
LUMEN, WHILE STILL MAINTAINING SUBSTANTIALLY NORMAL
FLOW THROUGH THE BODY LUMEN

5

Inventors

Howard Riina
Jeffrey Milson
J. Frederick Cornhill
Tuan Anh Nguyen
Kevin Smith
Kevin Keough
Robert Andrews

10

15

Reference To Pending Prior Patent Applications

This patent application:

(i) is a continuation-in-part of pending prior U.S. Patent Application Serial No. 12/657,598, filed 01/22/10 by Howard Riina et al. for METHOD AND APPARATUS FOR RESTRICTING FLOW THROUGH AN OPENING IN THE SIDE WALL OF A BODY LUMEN, AND/OR FOR REINFORCING A WEAKNESS IN THE SIDE WALL OF A BODY LUMEN, WHILE STILL MAINTAINING SUBSTANTIALLY NORMAL FLOW THROUGH THE BODY LUMEN (Attorney's Docket No. CORN-1819/D-4454-03(US)), which patent application (a) is in turn a continuation-in-part of prior U.S. Patent Application Serial No. 12/332,727, filed 12/11/08 by

20

25

- 2 -

Howard Riina et al. for METHOD AND APPARATUS FOR SEALING AN OPENING IN THE SIDE WALL OF A BODY LUMEN, AND/OR FOR REINFORCING A WEAKNESS IN THE SIDE WALL OF A BODY LUMEN, WHILE MAINTAINING SUBSTANTIALLY NORMAL FLOW THROUGH THE BODY LUMEN (Attorney's Docket No. CORN-1/D-4274-02 (US)), which in turn claims benefit of prior U.S. Provisional Patent Application Serial No. 61/007,189, filed 12/11/07 by Howard Riina et al. for DEPLOYABLE BLOCKING SPHERE (Attorney's Docket No. CORN-1 PROV/D-4274-01(US)); (b) claims benefit of prior U.S. Provisional Patent Application Serial No. 61/205,683, filed 1/22/09 by Jeffrey Milsom et al. for METHOD AND APPARATUS FOR SEALING AN OPENING IN THE SIDE WALL OF A BODY LUMEN, AND/OR FOR REINFORCING A WEAKNESS IN THE SIDE WALL OF A BODY LUMEN, WHILE MAINTAINING SUBSTANTIALLY NORMAL FLOW THROUGH THE BODY LUMEN (Attorney's Docket No. CORN-18 PROV/D-4454-01 (US)); and (c) claims benefit of prior U.S. Provisional Patent Application Serial No. 61/277,415, filed 9/24/09 by Howard Riina et al. for METHOD AND APPARATUS FOR RESTRICTING AN OPENING IN THE SIDE WALL OF A BODY LUMEN, AND/OR FOR REINFORCING A WEAKNESS IN THE SIDE WALL OF A BODY LUMEN, WHILE MAINTAINING SUBSTANTIALLY NORMAL FLOW THROUGH THE BODY LUMEN (Attorney's Docket No. CORN-19 PROV/D-4904-01); and (ii) claims benefit of pending prior U.S. Provisional Patent Application Serial No. 61/470,733,

- 3 -

filed 04/01/11 by Howard Riina et al. for FLOW
DIVERTERS (Attorney's Docket No. CORN-29 PROV).

The six (6) above-identified patent applications
are hereby incorporated herein by reference.

5

Field Of The Invention

This invention relates to medical procedures and
apparatus in general, and more particularly to medical
procedures and apparatus for restricting flow through
10 an opening in the side wall of a body lumen, and/or
for reinforcing a weakness in the side wall of a body
lumen, while still maintaining substantially normal
flow through the body lumen.

15

Background Of The Invention

The human body consists of many different
anatomical structures. Among these anatomical
structures are the blood vessels which circulate blood
throughout the body, i.e., the arteries which deliver
20 oxygenated blood to the end tissues and the veins
which return oxygen-depleted blood from the end
tissues.

25

In some cases, a blood vessel can become
weakened, thereby causing the side wall of the blood
vessel to balloon outwardly so as to create an
aneurysm. See, for example, Figs. 1-3, which show
various types of aneurysms, e.g., a fusiform aneurysm
(Fig. 1), where the aneurysm extends around a

- 4 -

substantial portion of the circumference of a blood vessel; a lateral aneurysm (Fig. 2), where the aneurysm extends out of a limited portion of the side wall of a blood vessel, with a well-defined neck; and
5 a bifurcation aneurysm (Fig. 3), where the aneurysm extends out of the apex of a bifurcation of a blood vessel. For purposes of the present invention, all of these aneurysms (e.g., fusiform aneurysms, lateral aneurysms and/or bifurcations aneurysms) are
10 considered to extend out of the side wall of a blood vessel.

Aneurysms can present a serious threat to the patient, since they may enlarge to the point of rupture, thereby resulting in a rapid and uncontrolled
15 loss of blood. Depending upon the size and location of the aneurysm, the aneurysm can be life-threatening.

By way of example but not limitation, an intracranial aneurysm can be fatal if rupture occurs. Given the life-threatening nature of such intracranial
20 aneurysms, these aneurysms have traditionally been treated with an open craniotomy and microsurgical clipping. This procedure generally involves placing a small titanium clip across the neck of the aneurysm, thus isolating the aneurysm from blood flow and
25 inhibiting subsequent rupture (or re-rupture). This clipping procedure is typically done under direct visualization, using an operating microscope.

- 5 -

More recently, minimally-invasive techniques have also been used to treat both ruptured and un-ruptured brain aneurysms. These minimally-invasive techniques generally employ interventional neuroradiological procedures utilizing digital fluoroscopy. More particularly, these interventional neuroradiological procedures generally use X-ray visualization to allow the surgeon to place a microcatheter within the dome of the aneurysm. With the microcatheter in place, detachable coils are then deployed within the dome of the aneurysm, thereby reducing blood velocity within the dome of the aneurysm and causing thrombosis of the aneurysm so as to prevent subsequent rupture (or re-rupture). However, this coil-depositing procedure has a number of drawbacks, including the risk of coil herniation into the lumen of the blood vessel; the risk of coil migration out of the aneurysm and into the blood vessel, with subsequent downstream migration; the risk of aneurysm rupture; etc.

As a result, a primary object of the present invention is to provide a new and improved device, adapted for minimally-invasive, endoluminal delivery, which may be used to restrict blood flow to an aneurysm while still maintaining substantially normal blood flow through the blood vessel.

Another object of the present invention is to provide an expandable spherical structure, comprising an open frame with a flow-restricting face (i.e., a

- 6 -

closed face or a face having a high strut density), which may be used to restrict flow through an opening in a side wall of a blood vessel while still maintaining substantially normal blood flow through the blood vessel.

Another object of the present invention is to provide an expandable spherical structure, comprising an open frame with a flow-restricting face (i.e., a closed face or a face having a high strut density), which may be used to reinforce a weakness in a side wall of a blood vessel while still maintaining substantially normal blood flow through the blood vessel.

Another object of the present invention is to provide an expandable spherical structure, comprising an open frame with a flow-restricting face (i.e., a closed face or a face having a high strut density), which may be used to restrict flow through an opening in the side wall of a lumen other than a blood vessel, and/or so as to reinforce a weakness in a side wall of a lumen other than a blood vessel, while still maintaining substantially normal flow through the lumen.

Another object of the present invention is to provide an expandable spherical structure which may be used to facilitate the deployment of detachable coils and/or other embolic material into the interior of an

- 7 -

aneurysm while still maintaining substantially normal flow through the blood vessel.

And another object of the present invention is to provide a method for manufacturing the novel device of the present invention.

Summary Of The Invention

These and other objects of the present invention are addressed through the provision and use of a novel expandable spherical structure, and a method for making the same.

In one form of the invention, there is provided an expandable substantially spherical structure for deployment in a blood vessel or other body lumen, comprising:

an open frame formed out of a closed loop of filament and configured to assume (i) a collapsed configuration in the form of a substantially two-dimensional elongated loop structure so as to facilitate insertion into the blood vessel or other body lumen, and (ii) an expanded configuration in the form of a three-dimensional substantially spherical structure so as to facilitate retention at a site in the blood vessel or other body lumen; and

a flow-restricting face carried by the open frame;

wherein the open frame is configured so as to permit substantially normal flow therethrough when the

- 8 -

open frame is in its expanded configuration, and further wherein the flow-restricting face is configured so as to restrict flow therethrough.

5 In another form of the invention, there is provided a system for restricting flow to an opening in the side wall of a blood vessel or other body lumen and/or reinforcing a weakness in the side wall or apex of a bifurcation of the blood vessel or other body lumen, while maintaining substantially normal flow
10 through the blood vessel or other body lumen, comprising:

an expandable substantially spherical structure for deployment in the blood vessel or other body lumen, comprising:

15 an open frame formed out of a closed loop of filament and configured to assume (i) a collapsed configuration in the form of a substantially two-dimensional elongated loop structure so as to facilitate insertion into the blood vessel or other
20 body lumen, and (ii) an expanded configuration in the form of a three-dimensional substantially spherical structure so as to facilitate retention at a site in the blood vessel or other body lumen; and

25 a flow-restricting face carried by the open frame;

wherein the open frame is configured so as to permit substantially normal flow therethrough when

- 9 -

the expandable open frame is in its expanded configuration, and further wherein the flow-restricting face is configured so as to restrict flow therethrough; and

5 an installation tool for carrying the expandable substantially spherical structure to a deployment site, wherein the installation tool comprises:

 an elongated structure having a first mount for seating a first portion of the closed loop and a
10 second mount for seating a second portion of the closed loop, the first mount and the second mount being movable relative to one another between a first position and a second position so that (i) when the first portion of the closed loop is seated in the
15 first mount and the second portion of the closed loop is seated in the second mount and the first mount and second mount are in their first position, the open frame is in its expanded substantially spherical configuration, and (ii) when the first portion of the
20 closed loop is seated in the first mount and the second portion of the closed loop is seated in the second mount and the first mount and second mount are in their second position, the open frame is in its collapsed and elongated configuration.

25 In another form of the invention, there is provided a method for restricting flow to an opening in the side wall of a body lumen while maintaining

- 10 -

substantially normal flow through the body lumen,
comprising:

providing an expandable substantially spherical
structure for deployment in the body lumen,

5 comprising:

an open frame formed out of a closed loop of
filament and configured to assume (i) a collapsed
configuration in the form of a substantially
two-dimensional elongated loop structure so as to
10 facilitate insertion into the blood vessel or other
body lumen, and (ii) an expanded configuration in the
form of a three-dimensional substantially spherical
structure so as to facilitate retention at a site in
the blood vessel or other body lumen; and

15 a flow-restricting face carried by the open
frame;

wherein the open frame is configured so as
to permit flow therethrough when the open frame is in
its expanded configuration, and further wherein the
20 flow-restricting face is configured so as to restrict
flow therethrough;

delivering the expandable substantially spherical
structure to a therapy site within the body lumen
while the open frame is in its collapsed
25 configuration; and

transforming the expandable substantially
spherical structure from its collapsed configuration
to its expanded configuration so that the expandable

- 11 -

substantially spherical structure is securely lodged
in the body lumen, with the flow-restricting face of
the expandable substantially spherical structure
positioned so as to restrict flow to the opening in
5 the side wall of the body lumen and with the open
frame permitting flow through the body lumen.

In another form of the invention there is
provided an expandable substantially spherical
structure for deployment in a blood vessel or other
10 body lumen, comprising:

an open frame configured to assume a collapsed
configuration and an expanded configuration;

a flow-restricting face carried by the open
frame; and

15 a plurality of stabilizing legs attached to, and
extending away from, the open frame;

wherein the open frame and the plurality of
stabilizing legs are configured so as to permit
substantially normal flow therethrough when the open
20 frame is in its expanded configuration, and further
wherein the flow-restricting face is configured so as
to restrict flow therethrough.

In another form of the invention, there is
provided a method for restricting flow through an
25 opening in the side wall of a body lumen while
maintaining substantially normal flow through the body
lumen, comprising:

- 12 -

providing an expandable substantially spherical structure for deployment in the body lumen, comprising:

5 an open frame configured to assume a collapsed configuration and an expanded configuration;

a flow-restricting face carried by the open frame; and

10 a plurality of stabilizing legs attached to, and extending away from, the open frame;

wherein the open frame and the plurality of stabilizing legs are configured so as to permit flow therethrough when the open frame is in its expanded configuration, and further wherein the flow-restricting face is configured so as to restrict flow therethrough;

15 delivering the expandable substantially spherical structure to a therapy site within the body lumen while the open frame is in its collapsed configuration and the plurality of stabilizing legs are in a collapsed configuration; and

20 transforming the expandable substantially spherical structure from its collapsed configuration to its expanded configuration, and transforming the plurality of stabilizing legs from their collapsed configuration to an expanded configuration, so that

25 the expandable substantially spherical structure is securely lodged in the body lumen, with the

- 13 -

flow-restricting face of the expandable substantially spherical structure positioned so as to restrict flow to the opening in the side wall of the body lumen and with the open frame and the plurality of stabilizing legs permitting flow through the body lumen.

5

In another form of the invention, there is provided a method for making a device for causing thrombosis of an aneurysm, wherein said device comprises a single elastic filament configurable between (i) an elongated, substantially linear configuration, and (ii) a longitudinally-contracted, substantially three-dimensional configuration, said method comprising:

10

providing a sheet of shape memory material;

15

producing a single filament, two-dimensional interim structure from said sheet of shape memory material;

20

mounting said single filament, two-dimensional interim structure to a fixture so that said single filament, two-dimensional interim structure is transformed into said longitudinally-contracted, substantially three-dimensional configuration; and

25

heat treating said single filament, two-dimensional interim structure while it is mounted to said fixture so as to produce said device in its longitudinally-contracted, substantially three-dimensional configuration.

- 14 -

In another form of the invention, there is provided a device for positioning in a blood vessel adjacent to an aneurysm for causing thrombosis of the aneurysm while maintaining substantially normal flow through the blood vessel, said device comprising:

a single elastic filament configurable between:

(i) an elongated, substantially linear configuration, whereby to facilitate movement along a blood vessel; and

(ii) a longitudinally-contracted, substantially three-dimensional configuration for lodging within the blood vessel, said longitudinally-contracted, substantially three-dimensional configuration providing (a) a face for positioning adjacent the aneurysm, said face comprising a plurality of lengths of said elastic filament in close proximity to one another so as to restrict blood flow to the aneurysm and thereby cause thrombosis of the aneurysm, and (b) a substantially open frame for holding said face adjacent the aneurysm, said substantially open frame configured so as to maintain substantially normal flow through the blood vessel;

wherein said single elastic filament has a width which varies along its length.

In another form of the invention, there is provided a method for making a device for causing thrombosis of an aneurysm, wherein said device comprises a single elastic filament configurable

- 15 -

between (i) an elongated, substantially linear configuration, and (ii) a longitudinally-contracted, substantially three-dimensional configuration, said method comprising:

5 providing a filament of shape memory material;
 mounting said filament of shape memory material to a fixture so that said filament is transformed into said longitudinally-contracted, substantially three-dimensional configuration; and

10 heat treating said filament so as to produce said device in its longitudinally-contracted, substantially three-dimensional configuration.

Brief Description Of The Drawings

15 These and other objects and features of the present invention will be more fully disclosed or rendered obvious by the following detailed description of the preferred embodiments of the invention, which is to be considered together with the accompanying
20 drawings wherein like numbers refer to like parts, and further wherein:

 Figs. 1-3 are schematic views showing various types of aneurysms;

25 Figs. 4-8 are schematic views showing a novel expandable spherical structure formed in accordance with the present invention, wherein the expandable spherical structure comprises an open frame with a flow-restricting face (i.e., a closed face in this

- 16 -

particular embodiment), and wherein the expandable spherical structure is shown being used to close off a lateral aneurysm in a blood vessel;

5 Figs. 9-13 are schematic views showing another novel expandable spherical structure formed in accordance with the present invention, wherein the expandable spherical structure comprises an open frame with a flow-restricting face (i.e., a closed face in this particular embodiment), wherein the open frame is
10 formed out of an absorbable material and the closed face is formed out of a non-absorbable material, and wherein the expandable spherical structure is shown being used to close off a lateral aneurysm in a blood vessel;

15 Figs. 14-18 are schematic views showing the expandable spherical structure of Figs. 4-8 being used to close off a bifurcation aneurysm;

20 Figs. 19-23 are schematic views showing the expandable spherical structure of Figs. 9-13 being used to close off a bifurcation aneurysm;

25 Fig. 24 is a schematic view showing another novel expandable spherical structure formed in accordance with the present invention, wherein the expandable spherical structure comprises an open frame with a flow-restricting face (i.e., a closed face in this particular embodiment), and wherein the open frame of the expandable spherical structure comprises a plurality of struts arranged in a rectangular pattern;

- 17 -

Fig. 25 is a schematic view showing another novel expandable spherical structure formed in accordance with the present invention, wherein the open frame comprises a plurality of struts arranged in a hexagonal pattern;

5

Fig. 26 is a schematic view showing another novel expandable spherical structure formed in accordance with the present invention, wherein the expandable spherical structure comprises an open frame with a flow-restricting face (i.e., a closed face in this particular embodiment), and wherein the open frame of the expandable spherical structure comprises a spherical spiral;

10

Fig. 27 is a schematic view showing another novel expandable spherical structure formed in accordance with the present invention, wherein the expandable spherical structure comprises an open frame with a flow-restricting face (i.e., a closed face in this particular embodiment), and wherein the open frame of the expandable spherical structure comprises a spherical cage;

15

20

Figs. 28-37 are schematic views showing other novel expandable spherical structures formed in accordance with the present invention, wherein the expandable spherical structures comprise spherical cages;

25

Figs. 38-43 are schematic views showing other novel expandable spherical structures formed in

- 18 -

accordance with the present invention, wherein the expandable spherical structure comprises an open frame with a flow-restricting face (i.e., a closed face in this particular embodiment), and wherein the
5 flow-restricting face is disposed to one side of the axis of approach;

Figs. 44 and 45 are schematic views showing the expandable spherical structure of Fig. 27 being deployed with a syringe-type (e.g., an outer sleeve
10 with an internal pusher) installation tool;

Fig. 46 is a schematic view showing the expandable spherical structure of Fig. 27 being deployed with a syringe-type installation tool equipped with a gripper mechanism;

15 Figs. 47-49 are schematic views showing the expandable spherical structure of Fig. 27 being deployed with a syringe-type installation tool equipped with an expansion balloon;

20 Figs. 50-54 are schematic views showing another novel expandable spherical structure formed in accordance with the present invention, wherein the expandable spherical structure comprises an open frame with a flow-restricting face (i.e., a face having a high strut density in this particular embodiment), and
25 wherein the expandable spherical structure is shown being used to restrict flow to a lateral aneurysm in a blood vessel;

- 19 -

Figs. 55-63 are schematic views showing other expandable spherical structures formed in accordance with the present invention, wherein the expandable spherical structures comprise open frames with flow-restricting faces (i.e., faces having high strut densities in these particular embodiments);

Figs. 64-66 are schematic views showing the expandable spherical structure of Figs. 4-8 being deployed within the interior of a lateral aneurysm so as to close off the aneurysm;

Figs. 67-71 are schematic views showing the expandable spherical structure of Figs. 9-13 being deployed within the interior of a lateral aneurysm so as to close off the aneurysm;

Figs. 72-76 are schematic views showing the expandable spherical structure of Figs. 4-8 being deployed within the interior of a bifurcation aneurysm so as to close off the aneurysm;

Figs. 77-81 are schematic views showing the expandable spherical structure of Figs. 9-13 being deployed within the interior of a bifurcation aneurysm so as to close off the aneurysm;

Figs. 82 and 83 are schematic views showing an expandable spherical structure having stabilizing legs extending therefrom so as to form a "comet-shaped" structure, with the structure being configured to restrict flow to a lateral aneurysm in a blood vessel;

- 20 -

Figs. 84-97 are schematic views showing various constructions for the "comet-shaped" structure of Figs. 82 and 83, but with the flow-restricting face of the expandable spherical structure being omitted in Figs. 84-91 for clarity of viewing;

Fig. 98 is a schematic view showing another comet-shaped structure, but with this structure being configured to restrict flow to a bifurcation aneurysm;

Figs. 99 and 100 show an expandable spherical structure restricting flow into a bifurcation aneurysm, where the expandable spherical structure is formed out of a "closed loop" of filament, and where the expandable spherical structure is deployed in the patient so that the face having a high strut density is positioned over the mouth/neck of the aneurysm in order to restrict flow into the aneurysm;

Figs. 101 and 102 are schematic views of an inserter which may be used with an expandable spherical structure formed out of a "closed loop" of filament;

Figs. 103-107 are schematic views showing how an expandable spherical structure formed out of a "closed loop" of filament may be deployed using the inserter of Figs. 101 and 102;

Fig. 108 is a schematic view showing one preferred method for forming a device in accordance with the present invention; and

- 21 -

Figs. 109-131 are schematic views showing another preferred method for forming a device in accordance with the present invention.

5 Detailed Description Of The Preferred Embodiments

The Novel Expandable Spherical Structure In General

Looking now at Figs. 4-8, there is shown a novel expandable spherical structure 5 formed in accordance
10 with the present invention. Expandable spherical structure 5 is adapted for minimally-invasive, endoluminal delivery into a blood vessel or other body lumen, for restricting flow through an opening in the side wall of the blood vessel or other body lumen,
15 and/or for reinforcing a weakness in the side wall of the blood vessel or other body lumen, while still maintaining substantially normal flow through the blood vessel or other body lumen.

Expandable spherical structure 5 generally
20 comprises a spherical body comprising an open frame 10 with a flow-restricting face 15 (i.e., a closed face or a face having a high strut density). Preferably open frame 10 and flow-restricting face 15 together define the entire exterior shape of the spherical
25 body, with open frame 10 making up the majority of the exterior shape of the spherical body.

In one preferred form of the invention, open frame 10 defines approximately 90% of the exterior

- 22 -

shape of the spherical body and flow-restricting face
15 defines approximately 10% of the exterior shape of
the spherical body. In another preferred form of the
invention, open frame 10 defines approximately 80% of
5 the exterior shape of the spherical body and
flow-restricting face 15 defines approximately 20% of
the exterior shape of the spherical body. In yet
another preferred form of the invention, open frame 10
comprises approximately 70% of the exterior shape of
10 the spherical body and flow-restricting face 15
defines approximately 30% of the exterior shape of the
spherical body. And in yet another preferred form of
the invention, open frame 10 comprises approximately
60% of the exterior shape of the spherical body and
15 flow-restricting face 15 comprises approximately 40%
of the exterior shape of the spherical body.

Expandable spherical structure 5 is constructed
so that it may be deployed in a blood vessel or other
body lumen, by (i) collapsing the expandable spherical
20 structure into a configuration of reduced dimension,
(ii) moving the collapsed structure through the blood
vessel or other body lumen to a therapy site, and
(iii) expanding the collapsed structure to an enlarged
dimension at the therapy site, whereby to secure the
25 expandable spherical structure in the blood vessel or
body lumen so that its flow-restricting face 15 is
presented to a side wall of the blood vessel or other
body lumen, whereby to restrict flow to an aneurysm or

- 23 -

other opening in the side wall of the blood vessel or other body lumen, or to otherwise reinforce a weakness in the side wall of the blood vessel or other body lumen, without significantly impeding normal flow through the blood vessel or other body lumen.

Significantly, by forming expandable spherical structure 5 in the shape of a spherical body, the endoluminal device is readily centered on the neck of an aneurysm or other opening in a body lumen, with flow-restricting face 15 projecting into the neck of the aneurysm or other opening in a body lumen and reliably restricting flow into the aneurysm or other opening in a body lumen.

Furthermore, by forming expandable spherical structure 5 so that it can expand at the therapy site and lodge itself in the blood vessel or other body lumen with its flow-restricting face 15 presented to a side wall of the blood vessel or other body lumen, expandable spherical structure 5 is effectively self-sizing, since it can be expanded to the degree necessary to span the blood vessel or other body lumen.

More particularly, expandable spherical structure 5 generally comprises an open frame 10 which has a flow restricting face 15 (i.e., a closed face or a face having a high strut density) carried thereon. Open frame 10 is formed so that it can assume a first, collapsed configuration of reduced dimension (Fig. 4)

- 24 -

so as to facilitate moving expandable spherical structure 5 endoluminally through the blood vessel or other body lumen to the therapy site. Open frame 10 is also formed so that it can thereafter be re-

5 configured to a second, expanded configuration of enlarged dimension (Figs. 5 and 6), whereby expandable spherical structure 5 can be lodged in the blood vessel or other body lumen at the therapy site, with its flow-restricting face 15 pressed securely against

10 a side wall of the blood vessel or other body lumen. In this position, flow-restricting face 15 of expandable spherical structure 5 can restrict flow to an aneurysm in the blood vessel (such as the lateral aneurysm shown in Figs. 4-8, or a bifurcation aneurysm

15 as will hereinafter be discussed below), or restrict flow to an opening in the side wall of the blood vessel or other body lumen, or reinforce a weakness in the side wall of the blood vessel or other body lumen, etc.

20 Significantly, by forming the endoluminal device as an expandable spherical structure, the device can be collapsed to a reduced dimension for minimally-invasive, endoluminal delivery into a blood vessel or other body lumen, yet can thereafter be expanded to

25 the required dimension for secure lodgement at the therapy site, whereby to restrict flow to an opening in a body lumen and/or to reinforce a weakness in the side wall of the body lumen. Furthermore, by forming

- 25 -

expandable spherical structure 5 in the shape of a spherical body, the endoluminal device is readily centered on the neck of an aneurysm or other opening in a body lumen, with flow-restricting face 15 projecting into the neck of the aneurysm or other opening in a body lumen and reliably restricting flow into the aneurysm or other opening in a body lumen. And by forming expandable spherical structure 5 so that it can expand at the therapy site and lodge itself in the blood vessel or other body lumen with its flow-restricting face 15 presented to a side wall of the blood vessel or other body lumen, expandable spherical structure 5 is effectively self-sizing, since it expands to the degree necessary to span the blood vessel or other body lumen. Additionally, by forming open frame 10 as an open structure, expandable spherical structure 5 can be disposed in the blood vessel or body lumen without significantly impeding normal flow through the blood vessel or other body lumen (Figs. 6-8).

Expandable Open Frame 10

As noted above, (i) expandable spherical structure 5 generally comprises a spherical body comprising an open frame 10 with a flow-restricting face 15 (i.e., a closed face or a face having a high strut density); (ii) open frame 10 and flow-restricting face 15 together preferably define

- 26 -

the entire exterior shape of the spherical body, with open frame 10 making up the majority of the exterior shape of the spherical body; (iii) open frame 10 is capable of being collapsed in dimension for easy
5 delivery of expandable spherical structure 5 to the therapy site and thereafter expanded in dimension at the therapy site so as to hold flow-restricting face 15 against a side wall of a blood vessel or other body lumen; and (iv) open frame 10 is configured so that it
10 does not significantly impede normal flow through the blood vessel or lumen within which it is deployed.

To this end, open frame 10 is preferably formed with an expandable strut construction, so that it can (i) first assume a configuration of reduced dimension,
15 so that expandable spherical body 5 can move easily through the body to the therapy site, and (ii) thereafter assume a configuration of expanded dimension, so that it can be securely retained at the desired location in the blood vessel or other body
20 lumen and press flow-restricting face 15 securely against the side wall of the blood vessel or body lumen, whereby to restrict flow to an aneurysm or other opening in the blood vessel or other body lumen, or to otherwise reinforce the side wall of the blood
25 vessel or other body lumen. And by forming open frame 10 with an expandable strut construction, open frame 10 is effectively self-sizing, since it expands to the

- 27 -

degree necessary to span the blood vessel or other body lumen.

5 Significantly, by forming open frame 10 with an expandable strut construction, open frame 10 does not significantly impede normal flow through the blood vessel or other body lumen when open frame 10 is in its expanded configuration within the blood vessel or other body lumen.

10 Thus, for example, in the configuration shown in Figs. 4-8, open frame 10 comprises a plurality of struts arranged in a polygonal configuration, with the struts being sized so that the struts present minimal obstruction to normal flow through the lumen.

15 In one preferred construction, open frame 10 may be formed out of a shape memory alloy (SMA) such as Nitinol, and a temperature transition may be used to change the configuration of open frame 10. By way of example but not limitation, open frame 10 can be formed so that when it is cooled to a temperature
20 below body temperature, the open frame assumes a collapsed configuration (Fig. 4), and when it is thereafter warmed to body temperature, the open frame assumes an expanded configuration (Fig. 6). If
25 desired, open frame 10 can be warmed to body temperature simply by deploying expandable spherical structure 5 in the body. Alternatively, an electrical current may be applied to open frame 10 so as to heat open frame 10 to its expansion temperature, e.g., via

- 28 -

resistance heating. Or, a warm or cold saline solution can be flushed through open frame 10 so as to appropriately modulate the temperature of the open frame, whereby to cause the open frame to assume a
5 desired configuration.

Alternatively, open frame 10 can be formed out of a resilient material which can be forcibly compressed into a collapsed configuration, restrained in this collapsed configuration, and thereafter released so
10 that it elastically returns to its expanded configuration. By way of example but not limitation, in this form of the invention, expandable spherical structure 5 might be compressed into a configuration of a reduced dimension, restrained within a sleeve,
15 delivered to the therapy site within the sleeve, and then released from the sleeve so that it elastically returns to an expanded configuration at the therapy site, whereby to lodge itself in the blood vessel or other body lumen, with its flow-restricting face
20 pressed against the side wall of the blood vessel or other body lumen. By way of further example but not limitation, open frame 10 can be formed out of a shape memory alloy (SMA) engineered to form stress-induced martensite (SIM) and thereby exhibit superelastic
25 properties, whereby to permit large shape deformations with elastic return. By way of still further example but not limitation, open frame 10 can be formed out of

- 29 -

a suitable polymer which exhibits the desired elastic properties.

In another preferred form of the present invention, open frame 10 is formed with a structure which can be collapsed for delivery to the deployment site and thereafter enlarged to an expanded configuration through the use of an expansion device, e.g., an internal balloon, where the balloon is inflated at the therapy site so as to reconfigure open frame 10 to an expanded condition. This arrangement can be advantageous, since it does not require the open frame to rely on temperature transition or elasticity to expand to its fully expanded configuration (or to any desired expanded configuration less than its fully expanded configuration). Thus, a wide range of well known biocompatible materials (e.g., medical grade stainless steel) may be used to form open frame 10.

20 Flow-Restricting Face 15

Flow-restricting face 15 is carried by (e.g., mounted on, formed integral with, or otherwise connected to) open frame 10 so that flow-restricting face 15 can be pressed securely against the side wall of the blood vessel or other body lumen within which expandable spherical structure 5 is deployed.

Flow-restricting face 15 may comprise a closed face, in the sense that it comprises a substantially

- 30 -

complete surface or barrier which is capable of closing off an aneurysm or other opening in side wall of a blood vessel or other body lumen, and/or for reinforcing a weakness in the side wall of the blood vessel or other body lumen. See Figs. 4-8, where flow-restricting face 15 is depicted as a closed face.

Alternatively, and as will be discussed in detail below, flow-restricting face 15 may comprise a face having a high strut density which is capable of restricting flow to an aneurysm or other opening in a side wall of a blood vessel or other body lumen, and/or for reinforcing a weakness in the side wall of the blood vessel or other body lumen. In this case, flow-restricting face 15 may not constitute a substantially complete surface, or flow-restricting face 15 may not constitute a substantially fluid-impervious surface, but flow-restricting face 15 will have a strut density sufficiently high to restrict flow through that face, e.g., so as to cause an aneurysm to thrombose.

Flow-restricting face 15 may be formed so as to be substantially rigid or it may be formed so as to be flexible.

Flow-restricting face 15 preferably has the convex configuration shown in Figs. 4-8, so that it can form a regular portion of the spherical body of expandable structure 5. However it should be appreciated that flow-restricting face 15 may also be

- 31 -

formed with a planar configuration, or some other configuration, if desired.

Use Of Absorbable Materials

5 If desired, expandable spherical structure 5 can have some or all of its elements formed out of an absorbable material, so that some or all of the elements are removed from the therapy site after some period of time has elapsed.

10 By way of example but not limitation, open frame 10 can be formed out of an absorbable material, and flow-restricting face 15 can be formed out of a non-absorbable material, so that only flow-restricting face 15 is retained at the therapy site after some
15 period of time has passed. See Figs. 9-13. This type of construction can be advantageous where flow-restricting face 15 integrates into the side wall of the blood vessel or other body lumen after some
20 period of time has elapsed, so that a supporting frame is no longer necessary to hold flow-restricting face 15 in position against the side wall of the blood vessel or other body lumen.

25 It is also possible for the entire expandable spherical structure 5 to be formed out of absorbable material(s), i.e., with both open frame 10 and flow-restricting face 15 being formed out of absorbable materials. This type of construction can be advantageous where flow-restricting face 15 only

- 32 -

needs to be held against the side wall of the blood vessel or other body lumen for a limited period of time, e.g., until aneurysm thrombosis/scarring is complete, or to reinforce the side wall of the blood vessel or other body lumen while healing occurs, etc.

It should also be appreciated that, where both open frame 10 and flow-restricting face 15 are absorbable, they may be engineered so as to have different absorption rates, so that they are removed from the therapy site at different times. This may be done by making the various elements out of different materials, or by making the various elements out of different blends of the same materials, etc.

Application To Different Types Of Aneurysms

As noted above, expandable spherical structure 5 can be used to restrict flow to various types of aneurysms.

Thus, for example, Figs. 4-8 and 9-13 show expandable spherical structure 5 being used to restrict flow to a lateral aneurysm (i.e., in these particular embodiments, to close off the lateral aneurysm).

However, it should also be appreciated that expandable spherical structure 5 may be used to restrict flow to a bifurcation aneurysm as well. Thus, for example, Figs. 14-18 show the expandable spherical structure 5 of Figs. 4-8 being used restrict

- 33 -

flow to a bifurcation aneurysm, and Figs. 19-23 show the expandable spherical structure 5 of Figs. 9-13 being used to restrict flow to a bifurcation aneurysm (i.e., in these particular embodiments, to close off the bifurcation aneurysm). In this respect it should be appreciated that the spherical shape of expandable spherical structure 5 is particularly well suited for use in treating bifurcation aneurysms, since it may be seated securely at the bifurcation, pressing flow-restricting face 15 securely against the bifurcation aneurysm, while still allowing blood to flow substantially unobstructed through the blood vessels.

It is also anticipated that expandable spherical structure 5 may be used to restrict flow to other types of aneurysms as well, e.g., certain forms of fusiform aneurysms. Where expandable spherical structure 5 is to be used to restrict flow to a fusiform aneurysm, flow-restricting face 15 may comprise a significantly enlarged surface area, or flow-restricting face 15 may comprise two or more separated segments disposed about the lateral portions of open frame 10, etc.

Structure Of Open Frame 10

It should be appreciated that open frame 10 can be formed with a variety of different configurations without departing from the scope of the present invention.

- 34 -

In one form of the invention, open frame 10 may be formed out of a plurality of struts arranged in a polygonal array. See, for example, Figs. 4-8, 9-13, 14-18 and 19-23, where open frame 10 is shown formed
5 out of a plurality of struts arranged as triangular polygons. See also Fig. 24, where open frame 10 is formed out of a plurality of struts arranged as rectangular polygons, and Fig. 25, where open frame 10 is formed out of a plurality of struts arranged as
10 hexagons.

It is also possible to form open frame 10 with a non-polygonal structure.

Thus, for example, open frame 10 may be formed with a spherical spiral structure, e.g., such as is
15 shown in Fig. 26, where a spiral strut forms the open frame 10.

Fig. 27 shows an open frame 10 having a spherical cage structure. More particularly, in this construction, open frame 10 comprises a plurality of
20 axially-aligned struts 20 which extend between flow-restricting face 15 and an annular ring 25. Struts 20 preferably bow outwardly when open frame 10 is in its expanded configuration, but may be bent inwardly (e.g., to a straight or inwardly-bowed
25 configuration) or otherwise deformed so as to permit open frame 10 to assume a reduced configuration. By way of example but not limitation, struts 20 may be bent inwardly (e.g., so as to extend substantially

- 35 -

parallel to one another) when open frame 10 is in its reduced configuration.

Figs. 28-37 show other spherical cage constructions wherein various struts 20 form open
5 frame 10.

It will be appreciated that, with the construction shown in Fig. 27, flow-restricting face 15 sits at one end of the plurality of axially-aligned struts 20 and annular ring 25 sits at the opposing end
10 of the plurality of axially-aligned struts 20. Since struts 20 are intended to be bowed inwardly so that the expandable spherical structure can assume a reduced configuration, the spherical cage structure of Fig. 27 is generally intended to be delivered axially,
15 with flow-restricting face 15 leading. Thus, this construction is particularly well suited for use with bifurcation aneurysms, where the neck of the aneurysm is typically axially-aligned with the direction of approach (see, for example, Figs. 14-18 and 19-23).
20 Accordingly, where the spherical cage structure is intended to be used with lateral aneurysms, it may be desirable to use the spherical cage configuration shown in Fig. 38, where flow-restricting face 15 is disposed to one side of the axis of approach, i.e., to
25 one side of the axis 27 shown in Fig. 38. In other words, where the spherical cage structure is intended to be used with a bifurcation aneurysm, flow-restricting face 15 is intended to be aligned

- 36 -

with the axis of approach, and where the spherical cage structure is intended to be used with a lateral aneurysm, flow-restricting face 15 is intended to be disposed to one side of the axis of approach. In this way, expandable spherical structure 5 can be endoluminally advanced to the therapy site and flow-restricting face 15 properly positioned relative to the anatomy.

Figs. 39-43 show other spherical cage constructions wherein various struts 20 form open frame 10 and flow-restricting face 15 is disposed to one side of the axis of approach.

Installation Tools

Various installation tools may be provided to deploy expandable spherical structure 5 within a blood vessel or other body lumen.

Thus, for example, in Fig. 44, there is shown a syringe-type (e.g., an outer sleeve with an internal pusher) installation tool 100 for deploying the expandable spherical structure 5 shown in Fig. 45. Installation tool 100 generally comprises a hollow sleeve 105 having a lumen 110 therein, and a pusher 115 slidably disposed within lumen 110. Lumen 110 is sized so that it can accommodate expandable spherical structure 5 when the expandable spherical structure is in its reduced configuration (Fig. 44), but not when it is in its enlarged configuration (Fig. 45). As a

- 37 -

result of this construction, expandable spherical structure 5 may be positioned within lumen 110 (distal to pusher 115) when expandable spherical structure 5 is in its reduced configuration, advanced to the therapy site while within sleeve 105, and then installed at the therapy site by advancing pusher 115 so that expandable spherical structure 5 is ejected from the interior of sleeve 105. Once expandable spherical structure 5 has been ejected from sleeve 105, expandable spherical structure 5 can return to an expanded configuration (Fig. 45) so as to be securely engaged in the blood vessel or other body lumen in the manner previously described, with flow-restricting face 15 pressed against a side wall of the blood vessel or other body lumen. It will be appreciated that the syringe-type installation tool 100 is particularly advantageous where expandable spherical structure 5 is elastically deformable, such that sleeve 105 can serve to mechanically restrain the expandable spherical structure in its reduced configuration while the expandable spherical structure is within sleeve 105, and release that mechanical constraint when the expandable spherical structure is ejected from sleeve 105.

As noted above, expandable spherical structure 5 of Figs. 27, 44 and 45 is well suited for use with bifurcation aneurysms, where the neck of the aneurysm is typically axially-aligned with the direction of

- 38 -

approach (see, for example, Figs. 14-18 and 19-23).
Where the spherical cage structure is intended to be
used with lateral aneurysms, it may be desirable to
use the spherical cage configuration shown in Fig. 38,
5 where flow-restricting face 15 is disposed to one side
of the axis of approach.

If desired, installation tool 100 can be provided
with a gripper mechanism to releasably secure
expandable spherical structure 5 to installation tool
10 100, e.g., so as to releasably secure expandable
spherical structure 5 to installation tool 100 until
after expandable spherical structure 5 has been
advanced to the therapy site and has returned to its
enlarged configuration, so that it is ready to be left
15 at the therapy site. This gripper mechanism ensures
complete control of expandable spherical structure 5
as it is moved out of the installation tool and
erected within the body, and also facilitates more
precise positioning (e.g., with proper rotation, etc.)
20 of the expandable structure against the side wall of
the body lumen.

More particularly, and looking now at Fig. 46,
installation tool 100 may be provided with a plurality
of spring grippers 125. Spring grippers 125 are
25 disposed within lumen 110 of sleeve 105, exterior to
pusher 115. Each spring gripper 125 is formed so that
when a bowed portion 130 of the spring gripper is
restrained within lumen 110, a hook portion 135 of

- 39 -

that spring gripper holds annular ring 25 of
expandable spherical structure 5 to the distal end of
pusher 115. However, when pusher 115 is advanced to
the point where bowed portion 130 of spring gripper
5 125 is no longer restrained within lumen 110, hook
portion 135 of spring gripper 125 moves outboard so as
to release annular ring 25 of expandable spherical
structure 5 from the distal end of pusher 115. Thus
it will be seen that spring grippers may be used to
10 releasably secure expandable spherical structure 5 to
installation tool 100 until after the expandable
spherical structure has been advanced out of the
distal end of the installation tool and returned to
its enlarged configuration. This arrangement can
15 provide the clinician with increased control as
expandable spherical structure 5 is deployed within
the blood vessel.

As noted above, expandable spherical structure 5
of Figs. 27 and 44-46 is well suited for use with
20 bifurcation aneurysms, where the neck of the aneurysm
is typically axially-aligned with the direction of
approach (see, for example, Figs. 14-18 and 19-23).
Where the spherical cage structure is intended to be
used with lateral aneurysms, it may be desirable to
25 use the spherical cage configuration shown in Fig. 38,
where closed face 15 is disposed to one side of the
axis of approach.

- 40 -

If desired, installation tool 100 can be provided with an expansion balloon for expanding the expandable spherical structure from its reduced configuration to its enlarged configuration. More particularly, and
5 looking now at Figs. 47-49, installation tool 100 may be provided with sleeve 105 and pusher 115 as discussed above. In addition, installation tool 100 may be provided with an expansion balloon 140. Expansion balloon 140 is supported on an inflation rod
10 145 which is movably disposed within pusher 115. Expansion balloon 140 is (in its deflated condition) disposed internal to open frame 10 of expandable spherical structure 5. As a result of this construction, installation tool 100 may receive
15 expandable spherical structure 5 while the expandable spherical structure is in its reduced configuration, carry the expandable spherical structure to the desired therapy site, position the expandable spherical structure at the desired location, and then
20 expand expansion balloon 140 so as to open the expandable spherical structure to its enlarged configuration. Expansion balloon 140 may then be deflated and withdrawn from the interior of expandable spherical structure 5. It will be appreciated that
25 providing installation tool 100 with an expansion balloon may be advantageous where expandable spherical structure 5 does not self-erect within the body lumen.

- 41 -

Expandable Spherical Structure Having A
Flow-Restricting Face Formed With A High Strut Density

In Figs. 1-50, flow-restricting face 15 of
expandable spherical structure 5 is depicted as a
5 closed face, in the sense that flow-restricting face
15 comprises a substantially complete surface or
barrier which is capable of closing off (and/or very
significantly reducing flow to) an aneurysm or other
opening in the side wall of a blood vessel or other
10 body lumen, and/or for reinforcing a weakness in the
side wall of the blood vessel or other body lumen.
However, it should be appreciated that for many
applications, flow-restricting face 15 need not
comprise a substantially complete surface or barrier,
15 i.e., flow-restricting face 15 may be formed with a
face having a sufficiently high strut density to form
an effectively closed face or to otherwise achieve a
desired purpose. Thus, for example, in Figs. 50-54,
there is shown an expandable spherical structure 5
20 comprising an open frame 10 having a flow-restricting
face 15 formed with a high strut density such that
blood flow to the aneurysm will be restricted and the
aneurysm will thrombose. In this circumstance,
flow-restricting face 15 may be considered to be
25 effectively closed. Furthermore, where
flow-restricting face 15 is being used to reinforce a
weakness in a side wall (as opposed to being used to
restrict flow to an opening in a side wall), closed

- 42 -

face 15 may have a somewhat lower strut density, since it does not need to significantly restrict the flow of a fluid.

5 Figs. 55-63 show other expandable spherical structures 5 wherein flow-restricting face 15 is formed with a sufficiently high strut density to achieve a desired purpose. In this respect it will be appreciated that, as used herein, the term strut is intended to mean substantially any element spaced from an adjacent element or in contact with an adjacent
10 element. Thus, where flow-restricting face 15 is formed by a face having a high strut density, the struts may be in the form of a screen, a mesh, a lattice, a series of parallel or concentric interlaced or otherwise patterned struts, etc.
15

It should also be appreciated that it is possible to form the entire expandable spherical structure 5 out of a single superelastic wire, e.g., a shape memory alloy constructed so as to form stress-induced
20 martensite at body temperatures. By way of example but not limitation, an appropriately blended and treated Nitinol wire may be used. In this form of the invention, the expandable spherical structure 5 can be (i) deformed into a collapsed configuration wherein a
25 single path of the wire is constrained within a restraining cannula, and (ii) thereafter reformed in situ by simply pushing the wire out of the distal end of the restraining cannula, whereupon expandable

- 43 -

spherical structure 5 reforms in the blood vessel or other body lumen. This form of the invention is particularly well suited to constructions where flow-restricting face 15 is formed with a single, patterned strut arranged to have a high strut density, e.g., with a strut density sufficiently high to restrict flow to the mouth of an aneurysm, and/or a strut density sufficiently high to reinforce the side wall of a blood vessel or other body lumen, and/or a strut density sufficiently high to achieve some other desired purpose. See, for example, Figs. 59-63, which show flow-restricting face 15 formed out of a single, patterned strut, where the strut pattern may comprise one or more of a variety of configurations, e.g., with parallel paths, concentric paths, switchback paths, serpentine paths, etc.

Utilizing The Expandable Spherical Structure In
Conjunction With Thrombosis-Inducing Coils

As noted above, conventional minimally-invasive techniques for treating brain aneurysms generally involve depositing thrombosis-inducing coils within the dome of the aneurysm. If desired, the expandable spherical structure 5 of the present invention may be used in conjunction with thrombosis-inducing coils, i.e., the thrombosis-inducing coils may be deposited within the dome of an aneurysm after positioning the expandable spherical structure against the mouth of

- 44 -

the aneurysm so as to restrict flow into the aneurysm, i.e., by introducing the thrombosis-inducing coils through the face having a high strut density and into the dome of the aneurysm. Alternatively, the
5 thrombosis-inducing coils may be deposited within the dome of the aneurysm before positioning the expandable spherical structure against the mouth of the aneurysm so as to restrict flow into the aneurysm. Significantly, it is believed that this approach will
10 both facilitate thrombosis formation and also prevent coil migration out of the aneurysm.

Deploying The Expandable Spherical Structure
Within An Aneurysm

15 It should also be appreciated that expandable spherical structure 5 may be deployed within the body of an aneurysm so that its flow-restricting face 15 confronts the lumen, rather than being within the lumen so that its flow-restricting face confronts the
20 body of the aneurysm. See, for example, Figs. 64-66, which show the expandable spherical structure 5 of Figs. 4-8 deployed within the body of the aneurysm. See also, for example, Figs. 67-71, which show the expandable spherical structure 5 of Figs. 9-13 being
25 disposed within the body of the aneurysm.

Again, the expandable spherical structure 5 may be positioned within the interior of a lateral

- 45 -

aneurysm (Figs. 64-66 and 67-71) or it may be disposed within a bifurcated aneurysm (Figs. 72-76 and 77-81).

Expandable Spherical Structure With Stabilizing Legs -
5 "Comet-Shaped Structure"

It is also possible to provide expandable spherical structure 5 with stabilizing legs. Such a construction may be adapted for use with both lateral aneurysms and with bifurcation aneurysms.

10 More particularly, and looking now at Figs. 82 and 83, there is shown an expandable spherical structure 5 which comprises an open frame 10 with a flow-restricting face 15. Extending out of open frame 10 are one or more stabilizing legs 30. Stabilizing
15 legs 30 are formed so that, when flow-restricting face 15 is positioned against the side wall of a blood vessel or other body lumen, stabilizing legs 30 extend endoluminally through the blood vessel or other body lumen. Thus it will be appreciated that the
20 expandable spherical structure 5 shown in Figs. 82 and 83 is generally intended to be used with a lateral aneurysm, since the center axis 35 of stabilizing legs 30 is set at a right angle to the center axis 40 of flow-restricting face 15 (see Fig. 83).

25 Preferably, and as seen in Figs. 82 and 83, stabilizing legs 30 together form a somewhat cone-shaped structure, so that the overall shape of open frame 10 (with flow-restricting face 15) and

- 46 -

stabilizing legs 30 is a generally comet-shaped structure.

As seen in Fig. 84, this comet-shaped structure may be compressed within a containment sheath 200, with stabilizing legs 30 leading and with open frame 10 (with flow-restricting face 15) trailing, and with a push catheter 205 and tension wire 210 engaging open frame 10 of expandable spherical structure 5. At the aneurysm site, push catheter 205 ejects the comet-shaped structure, "legs first", so that closed face 15 restricts access to the mouth of the aneurysm while stabilizing legs 30 help maintain the position of open frame 10 (and flow-restricting face 15) within the blood vessel. This deployment procedure is preferably conducted over a guidewire 215.

If the comet-shaped structure subsequently needs to be repositioned or removed from a deployment site, tension wire 210 may be used to pull the comet-shaped structure retrograde, e.g., within the blood vessel or all the way back into containment sheath 200. To this end, and looking now at Figs. 85-87, open frame 10 of expandable spherical structure 5 may comprise a proximal end ring 220, and tension wire 210 may comprise an expandable head 225 adapted to extend through proximal end ring 220 and then expand, whereupon the comet-shaped structure may be moved retrograde. Alternatively, open frame 10 of

- 47 -

expandable spherical structure 5 may comprise an apex
230 of converging wires which can be gripped by a
J-hook 235 formed on the distal end of tension wire
210 (Fig. 88) or by C-fingers 240 formed on the distal
5 end of tension wire 210 (Fig. 89).

If desired, and looking now at Figs. 85-87, the
distal ends of stabilizing legs 30 may be turned into
eyelets 245, so as to minimize trauma (during both
placement and repositioning) to the side wall of the
10 body lumen (e.g., blood vessel) in which they are
disposed.

It will be appreciated that, where
flow-restricting face 15 covers only a portion of the
circumference of open frame 10, it can be important
15 for the clinician to ensure the rotational disposition
of the comet-shaped structure so that flow-restricting
face 15 is properly aligned with the mouth of the
lateral aneurysm. For this reason, and looking now at
Fig. 90, push catheter 205 may include a plurality of
20 slits 250 on its distal end which receive the
constituent wires of open frame 10, whereby to permit
the clinician to adjust the rotational disposition of
the comet-shaped structure (and hence the rotational
disposition of flow-restricting face 15 of open frame
25 10). Alternatively, and looking now at Fig. 91, push
catheter 205 may be formed with an obround shape (or
any other appropriate non-circular shape) so as to
permit the clinician to specify the rotational

- 48 -

disposition of the comet-shaped structure (and hence the rotational disposition of flow-restricting face 15 of open frame 10).

Looking now at Figs. 92 and 93, flow-restricting face 15 of open frame 10 can be formed by wrapping a membrane 255 over the wire skeleton making up open frame 10 and securing it in position. Thus, Figs. 94 and 95 show membrane 255 covering only a portion of the circumference of frame 10, and Figs. 96 and 97 show membrane 255 covering the complete circumference of frame 10.

In the foregoing description, the expandable spherical structure 5 of Figs. 82 and 83 is discussed in the context of a "legs-first" deployment into the blood vessel or other body lumen. However, it should also be appreciated that the expandable spherical structure 5 of Figs. 82 and 83 may be deployed "head-first" into the blood vessel or other body lumen (i.e., with stabilizing legs 30 trailing open frame 10).

Looking next at Fig. 98, it is also possible to provide a comet-shaped structure which can be used with a bifurcation aneurysm. More particularly, in this form of the invention, expandable spherical structure 5 is formed so that center axis 40 of flow-restricting face 15 is aligned with center axis 35 of stabilizing legs 30. It will be appreciated that where the comet-shaped structure is to be used

- 49 -

with to treat a bifurcation aneurysm, it is generally desirable that the "head" of the comet (which comprises flow-restricting face 15) be ejected out of containment sheath 200 first, with stabilizing legs 30 trailing, whereby to easily place flow-restricting face 15 against the mouth of the aneurysm.

Expandable Spherical Structure Formed
Out Of A "Closed Loop" Of Filament

10 In the preceding description, expandable spherical structure 5 is described as comprising an open frame 10 having a flow-restricting face 15 carried thereon. More particularly, in some embodiments of the invention, flow-restricting face 15
15 comprises a substantially complete surface or barrier. See, for example, Figs. 4-49. However, in other embodiments of the invention, flow-restricting face 15 need not comprise a substantially complete surface or barrier, i.e., flow-restricting face 15 may be formed
20 with a face having a sufficiently high strut density to form an effectively closed face or to otherwise achieve a desired purpose. Thus, for example, in Figs. 50-58, there is shown an expandable spherical structure 5 comprising an open frame 10 having a
25 flow-restricting face 15 formed with a high strut density such that blood flow to the aneurysm will be restricted and the aneurysm will thrombose. In this circumstance, flow-restricting face 15 may be

- 50 -

considered to be effectively closed, in the sense that flow-restricting face 15 is sufficiently closed to decrease flow velocity in the aneurysm and result in thrombosis within the aneurysm. Furthermore, where
5 flow-restricting face 15 is being used to reinforce a weakness in a side wall (as opposed to being used to close off an opening in a side wall or to otherwise restrict flow through that opening), flow-restricting face 15 may have a somewhat lower strut density. In
10 any case, however, flow-restricting face 15 will still have a significantly higher strut density than that of open frame 10.

In the preceding description, it was noted that it is possible to form the entire expandable spherical
15 structure 5 out of a single superelastic wire, e.g., a shape-memory alloy constructed so as to form stress-induced martensite at body temperatures. It was also noted that, in this form of the invention, the expandable spherical structure 5 can be (i)
20 deformed into a collapsed configuration wherein a single path of the wire is constrained within a constraining cannula, and (ii) thereafter reformed in situ by simply pushing the wire out of the distal end of the restraining cannula, whereupon expandable
25 spherical structure 5 reforms in the blood vessel or other body lumen. It was further noted that this form of the invention is particularly well suited to constructions wherein closed face 15 is formed with a

- 51 -

single, patterned strut arranged to have a high strut density, e.g., with a strut density sufficiently high to restrict the flow of blood through the mouth of an aneurysm (i.e., to cause thrombosis of the aneurysm),
5 and/or a strut density sufficiently high to reinforce the side wall of a blood vessel or other body lumen, and/or a strut density sufficiently high to achieve some other desired purpose. Again, however, flow-restricting face 15 will still have a
10 significantly higher strut density than that of open frame 10. See, for example, Figs. 59-63, which show flow-restricting face 15 formed out of a single, patterned strut, where the strut pattern may comprise one or more of a variety of configurations, e.g., with
15 parallel paths, concentric paths, switchback patterns, serpentine paths, etc.

In accordance with the present invention, there is now disclosed a further construction wherein expandable spherical structure 5 is formed out of a
20 closed loop of filament such as highly flexible wire (e.g., Nitinol) which has been worked (e.g., on a mandrel) so that its numerous turns approximate the shape of a sphere or ellipsoid when the loop is in its relaxed condition. One face of the sphere (i.e.,
25 flow-restricting face 15) has a higher turn density than the remainder of the sphere (i.e., open frame 10) so that the high density face can restrict blood flow while the remainder of the sphere easily passes blood

- 52 -

flow. The closed loop of filament may be transformed from its spherical shape into another shape by applying physical forces (e.g., tension) to the closed loop of filament. Thus, the closed loop of filament
5 may be transformed from its three-dimensional substantially spherical configuration into a substantially two-dimensional "elongated loop" configuration (e.g., by applying two opposing forces to the interior of the loop) in order that the closed
10 loop of filament may be advanced endoluminally to the site of an aneurysm. Once at the site of the aneurysm, the tension on the elongated loop may be released so that the closed loop of filament returns to its spherical shape, whereby to lodge in the blood
15 vessel with the high density face (i.e., flow-restricting face 15) diverting the flow of blood away from the aneurysm (i.e., to cause thrombosis within the aneurysm) while the remainder of the sphere (i.e.,
20 open frame 10) easily passes blood flowing through the parent vessel. If the sphere subsequently needs to be re-positioned within the blood vessel, the tension is re-applied to the sphere so as to transform it part or
25 all the way back to its elongated loop configuration, the position of the device is adjusted, and then the foregoing process repeated so as to set the sphere at a new position within the blood vessel. Furthermore, if the sphere needs to be removed from the blood vessel, the tension is re-applied to the sphere so as

- 53 -

to transform it back to its elongated loop configuration, and then the loop is removed from the patient. Significantly, this construction has the advantages of (i) ease of positioning, (ii) reliably
5 maintaining its deployed position within the vessel, (iii) ease of re-positioning within the body, and (iv) where necessary, removal from the body.

By way of example but not limitation, Fig. 63
10 shows a expandable spherical structure 5 which is formed out of a closed loop of highly flexible wire. As can be seen in Fig. 63, expandable spherical structure 5 approximates the shape of a sphere or ellipsoid when the loop is in its relaxed condition.
15 Fig. 63 shows expandable spherical structure 5 being used to restrict blood flow to a lateral aneurysm. Figs. 99 and 100 show expandable spherical structure 5 being used to restrict blood flow to a bifurcation aneurysm.

20 Fig. 101 and 102 shows an inserter 300 which can be used to reconfigure such a "closed loop" expandable spherical structure 5 from its relaxed spherical (or elliptical) configuration into an elongated loop configuration. To this end, inserter 300 preferably
25 comprises an inner catheter 305 which includes a bifurcated distal end 310 which can seat a segment of the closed loop. Inserter 300 preferably also

- 54 -

comprises an outer catheter 315 which includes a mount 320 which can seat another segment of the closed loop.

In use, and as shown in Figs. 103-107, inserter 300 is set so that its outer catheter 315 is adjacent to bifurcated distal end 310, and then a segment of the closed loop expandable spherical structure 5 is seated in bifurcated distal end 310 and another segment of the closed loop expandable spherical structure is seated in mount 320 of outer catheter 315. Then outer catheter 315 is moved proximally so that the closed loop expandable spherical structure 5 is reconfigured from its relaxed spherical (or elliptical) configuration into an elongated loop configuration, e.g., in the manner of a tensioned elastic band. With the closed loop expandable spherical structure 5 held in this elongated condition on inserter 300, a transport sheath 325 is (optionally) be placed over the assembly. Inserter 300 (with its passenger closed loop expandable spherical structure 5 and with its overlying transport sheath 325) is moved through the patient's anatomy until spherical structure 5 is located at the surgical site. Then transport sheath 325 is removed and outer catheter 315 is moved distally on inner catheter 305. As outer catheter 315 is moved distally on inner catheter 305, tension on expandable spherical structure 5 is released so that expandable spherical structure 5 can re-assume its spherical or elliptical

- 56 -

the term "spherical" is intended to mean a true spherical shape, and/or a substantially spherical shape, and/or a near spherical shape (including but not limited to an ellipsoid shape or a substantially ellipsoid shape or a near ellipsoid shape), and/or an effectively spherical shape, and/or a generally spherical shape, and/or a polyhedron which approximates a sphere, and/or a shape which approximates a sphere, and/or a structure comprising a substantial portion of any of the foregoing, and/or a structure comprising a combination of any of the foregoing, etc.

Thus, for example, expandable spherical structure may include a first section that constitutes a portion of a sphere and a second section which roughly approximates the remaining portion of a sphere.

Method For Manufacturing The Novel Device

From A Single Elastic Filament

In the foregoing disclosure, there is disclosed a novel device for, among other things, positioning in a blood vessel (or vessels) adjacent to the mouth of an aneurysm and for causing thrombosis of the aneurysm by restricting blood flow to the aneurysm while maintaining substantially normal blood flow through the blood vessel (or vessels) which receive(s) the device, wherein the device comprises a single elastic filament configurable between: (i) a longitudinally-

- 57 -

expanded, substantially linear configuration, whereby
to facilitate movement of the device along the
vascular system of the patient to the site of the
aneurysm; and (ii) a longitudinally-contracted,
5 substantially three-dimensional configuration for
lodging within the central lumen of the blood vessel
(or vessels) adjacent to the mouth of the aneurysm,
the longitudinally-contracted, substantially three-
dimensional configuration providing (a) a flow-
10 restricting face for positioning at the mouth of the
aneurysm, the flow-restricting face comprising a
plurality of lengths of the single elastic filament
disposed in close proximity to one another so as to
significantly restrict blood flow to the aneurysm and
15 thereby cause thrombosis of the aneurysm, and (b) a
substantially open frame for holding the flow-
restricting face adjacent to the mouth of the
aneurysm, the substantially open frame being
configured so as to maintain substantially normal
20 blood flow through the central lumen of the blood
vessel (or vessels) which receive(s) the device.

In one preferred form of the present invention,
the novel device is formed out of a single elastic
filament having distinct first and second ends, and
25 the longitudinally-expanded, substantially linear
configuration is formed by disposing the first and
second ends oppositely away from one another. In
another preferred form of the present invention, the

- 58 -

device is formed out of a single elastic filament having its first and second ends unified with one another (e.g., by welding, by banding, etc.) so as to effectively form a continuous, closed loop of elastic filament, and the longitudinally-expanded, substantially linear configuration is formed by disposing the continuous, closed loop of elastic filament so that it essentially consists of two parallel lengths of the single elastic filament.

And in one preferred form of the present invention, the longitudinally-contracted, substantially three-dimensional configuration is substantially spherical, or substantially ellipsoid, or some other three-dimensional shape appropriate for holding the flow-restricting face of the device against the mouth of the aneurysm while maintaining substantially normal blood flow through the central lumen of the blood vessel (or vessels) which receive(s) the device.

And in one preferred form of the present invention, the single elastic filament comprises a shape memory material, e.g., Nitinol, with the elastic filament transforming between its longitudinally-expanded, substantially linear configuration and its longitudinally-contracted, substantially three-dimensional configuration by temperature transition or by superelasticity.

- 59 -

And in one preferred form of the present invention, the shape memory material may comprise an appropriate nickel titanium alloy (e.g., Nitinol), an appropriate copper-based alloy (e.g., Cu-Zn-Al, 5 Cu-Al-Ni, Cu-Al-Mn, Cu-Al-Be, etc.), and an appropriate iron-based alloy (e.g., Fe-Mn-Si, Fe-Cr-Ni-Mn-Si-Co, Fe-Ni-Mn, Fe-Ni-C, Fe-Pt, Fe-Pd, etc.), etc. Additionally, the shape memory material may comprise a shape memory polymer.

10 In order for a shape memory material to be capable of automatically transforming between a "first shape" and a "second shape" by temperature transition or by superelasticity, it is necessary to first process the shape memory material in a particular 15 manner. More particularly, the shape memory material is initially formed with the "first shape", then it is mechanically transformed to the desired "second shape" and then, while mechanically held in the desired "second shape" (e.g., by a fixture), the shape memory 20 material is heat treated, i.e., it is brought to an elevated temperature for a controlled length of time and then rapidly quenched so as to return the shape memory material to ambient temperature. This processing causes the shape memory material to retain 25 its aforementioned "second shape", even after the device is released from the fixture. Thereafter, the shape memory material may be transformed from its "second shape" to its "first shape" (e.g., by

- 60 -

temperature transition or by mechanical deformation)
and then, when desired, automatically returned to its
"second shape" (e.g., by a different temperature
transition or by releasing the mechanical
5 deformation).

Thus it will be seen that, in connection with the
present invention, when the novel device is to be
formed out of a shape memory material, with the
"second shape" being the aforementioned
10 longitudinally-contracted, substantially three-
dimensional configuration and the "first shape" being
the aforementioned longitudinally-expanded,
substantially linear configuration, the device must be
held in its "second shape" on a fixture while the
15 shape memory material is appropriately heat treated
(e.g., heated and then rapidly quenched) so that the
device will thereafter retain its "second shape" when
it is released from the fixture.

In one preferred form of the present invention,
20 the elastic filament comprises shape memory material
wire (e.g., Nitinol wire), and the novel device is
formed by first winding the elastic filament around a
plurality of surface features (e.g., posts) disposed
on (or in) a three-dimensional body (i.e., "the
25 fixture"), and then appropriately heat treating the
elastic filament while it is retained on the fixture
so that the elastic filament will retain the desired
"second shape" (i.e., the aforementioned

- 61 -

longitudinally-contracted, substantially three-dimensional configuration) when the device is released from the fixture. See, for example, Fig. 108, which shows a novel device 400 comprising a single elastic filament 405, wherein the elastic filament 405 is wound around a plurality of posts 410 which are mounted on a three-dimensional (e.g., spherical) body 415 (i.e., "the fixture") for appropriate heat treatment. It will be appreciated that this approach may be used regardless of whether the single elastic filament has distinct first and second ends or has its first and second ends unified with one another (e.g., by welding, by banding, etc.) so as to effectively form a continuous, closed loop.

The foregoing manufacturing approach, which may sometimes be referred to herein as the "winding" approach, is highly advantageous since it allows the elastic filament to be formed out of shape memory material wire (e.g., Nitinol wire), which is well known in the art. As a result, it is possible to take advantage of the substantial body of general knowledge which already exists with respect fabricating, handling and heat treating shape memory material wire (e.g., Nitinol wire).

However, as noted above, this "winding" approach requires that the elastic filament be wound around surface features (e.g., posts) disposed on (or in) a three-dimensional body (i.e., "the fixture").

- 62 -

In another preferred form of the present invention, there is provided an alternative manufacturing approach, which may sometimes be referred to herein as the "flat-to-3D" approach.

5 Generally described, with this "flat-to-3D" approach, and looking now at Figs. 109-111, a flat sheet 420 of shape memory material (e.g., Nitinol) is patterned so as to create at least one, and preferably a plurality of, single filament, two-dimensional interim
10 structures 425 (Figs. 109 and 110). These single filament, two-dimensional interim structures 425 are thereafter released (i.e., separated) from the flat sheet 420 (e.g., by severing an attachment tab 430 connecting the single filament, two-dimensional
15 interim structure 425 to the flat sheet 420 of shape memory material), and then mounted onto an appropriate three-dimensional body (i.e., "the fixture") for heat treating (i.e., heating and rapidly quenching), so that the single filament, two dimensional interim
20 structure 425 will thereafter assume the desired "second shape" (i.e., the aforementioned longitudinally-contracted, substantially three-dimensional configuration) 435 (Fig. 111) when the device is thereafter released from the fixture,
25 whereby to provide the desired shape for the device.

More particularly, the aforementioned longitudinally-contracted, substantially three-dimensional configuration 435 of the device (Fig. 111)

- 63 -

is projected into a corresponding two-dimensional configuration 440 (Fig. 112) for the device. This two-dimensional projection 440 of the device (Fig. 112) corresponds to the single filament, two-dimensional interim structure 425 referred to above. This two-dimensional projection 440 of the device (Fig. 112) is then used to fabricate the single filament, two-dimensional interim structure 425 from a flat sheet 420 of shape memory material.

In one preferred form of the invention, and looking now at Fig. 113, a plurality of these single filament, two-dimensional interim structures 425 are produced from one flat sheet 420 of shape memory material. This may be effected using a number of different fabrication techniques, including chemical etching, laser cutting, etc. Chemical etching is currently generally preferred, and may yield the single filament, two-dimensional interim structures 425 shown in Figs. 114, 116 and 118, with each individual single filament, two-dimensional interim structure 425 being attached to the flat sheet 420 of shape memory material by at least one attachment tab 430. Preferably the single filament, two-dimensional interim structure 425 carried by the flat sheet 420 of shape memory material is then electro-polished, which is a "reverse plating" process that electrochemically removes additional material. This occurs preferentially at sharp corners, where the electrical

- 64 -

fields are the strongest, thereby advantageously rounding off sharp corners. See, for example, Figs. 115, 117 and 119, which show the etched structures of Figs. 114, 116 and 118, respectively, after electro-
5 polishing.

Thereafter, the single filament, two-dimensional interim structure 425 is dismounted from the flat sheet 420 of shape memory material (e.g., by severing the one or more attachment tabs 430 holding the single
10 filament, two-dimensional interim structure 425 to the flat sheet 420 of shape memory material), and then the freed single filament, two-dimensional interim structure 425 is mounted on an appropriate three-dimensional fixture so that the single filament, two-
15 dimensional interim structure 425 assumes the desired "second shape", i.e., the aforementioned longitudinally-contracted, substantially three-dimensional configuration.

See, for example, Figs. 120-125, which show a
20 two-part fixture 450 comprising a male half 455 and a female half 460. Male half 455 comprises a three-dimensional (e.g., spherical) body 465 having a plurality of posts 470 mounted thereon. Female half 460 comprises a three-dimensional (e.g., spherical)
25 cavity 475 which is the substantial inverse of at least a portion of three-dimensional body 465. The single filament, two-dimensional interim structure 425 is set on the three-dimensional body 465 using posts

- 65 -

470 to stabilize the single filament, two-dimensional interim structure, and then the two halves 455, 460 are brought together so as to force the single filament, two-dimensional interim structure 425 to
5 assume the desired "second" shape (i.e., the aforementioned longitudinally-contracted, substantially three-dimensional configuration).

With the single filament, two-dimensional interim structure 425 restrained in the desired "second shape"
10 (i.e., the aforementioned longitudinally-contracted, substantially three-dimensional configuration), the device is heat treated (i.e., it is appropriately heated and then rapidly quenched to ambient temperature) so as to "train" the device to assume the
15 desired "second shape" (i.e., the longitudinally-contracted, substantially three-dimensional configuration). The device may thereafter be dismounted from the three-dimensional fixture, whereby
20 to provide the structure 435 shown in Fig. 111, and thereafter used in the manner previously discussed.

In connection with the foregoing, the following additional points should be appreciated.

Device Design.

25 In certain circumstances, it may be desirable to form certain portions of the novel device with a stiffer characteristic than other portions of the device, which may require a more flexible characteristic. By way of example but not limitation,

- 66 -

by forming certain portions of the device with a stiffer characteristic, the ability of the device to return to its longitudinally-contracted, substantially three-dimensional configuration 435 (Fig. 111) may be enhanced. This can be extremely useful where the device is made with a relatively thin elastic filament in order to fabricate a relatively small device, since a relatively thin elastic filament may not generate adequate return forces to restore the device to its longitudinally-contracted, substantially three-dimensional configuration 435 (Fig. 111) when the device is disposed in a blood vessel (or vessels).

One way of providing regions of greater or lesser stiffness is by forming the elastic filament with regions of thicker or thinner dimensions. This is relatively easy to do with the "flat-to-3D" approach of the present invention, where the single filament, two-dimensional interim structure 425 is being formed out of a large flat sheet 420 of shape memory material. In this case, the regions of greater stiffness are formed thicker (e.g., wider) and the regions of lesser stiffness are formed thinner (e.g., narrower).

By way of example but not limitation, where etching is used to fabricate the single filament, two-dimensional interim structure 425 from a flat sheet 420 of shape memory material, the process is essentially a subtractive process where material is

- 67 -

etched away. As a result, different thicknesses
(e.g., widths) may be provided for the elastic
filament by etching away more or less material from
flat sheet 420. See, for example, Fig. 110, where
5 portions 480 of single filament, two-dimensional
interim structure 425 have a greater thickness (e.g.,
width) than portions 485 of single filament, two-
dimensional interim structure 425. This construction
is retained in the longitudinally-contracted,
10 substantially three-dimensional configuration 435
(Fig. 111) which is produced from the single filament,
two-dimensional interim structure 425 after
appropriate heat treatment on a fixture (e.g., the
two-part fixture 450 shown in Figs. 120-125).

15 Another way of forming regions of greater or
lesser stiffness is by forming the elastic filament
with regions of differing cross-section. By way of
example but not limitation, where the device has a
round cross-section, the device will tend to bend
20 equally well in all directions when the bend occurs at
that cross-section, but where the device has a
rectangular cross-section, the device will tend to
bend preferentially in certain directions when the
bend occurs at that cross-section. Accordingly, it is
25 possible to form regions of greater or lesser
stiffness by intentionally varying the cross-section
of the device along its length, whereby to provide the
device with the mechanical properties desired for

- 68 -

various segments of the device. Again, this is relatively easy to do with the "flat-to-3D" approach of the present invention, where the single filament, two-dimensional interim structure 425 is being formed out of a large flat sheet 420 of shape memory material via a subtractive process, since the subtractive process can be used to provide various cross-sections at different points along the device.

Furthermore, the material (e.g., metallurgical) properties of the flat sheet 420 of shape memory material are not necessarily the same in all directions. By way of example but not limitation, the shape memory material may be stronger in one direction than in another direction, e.g., the shape memory material may be stronger in the direction in which it is rolled during the manufacturing process than in the opposing direction. By taking such factors into account when forming the single filament, two-dimensional interim structure 425 from the flat sheet 420 of shape memory material, it is possible to take advantage of varying material properties, e.g., so as to construct devices which can be better stretched or compressed in selected directions.

Etching.

Etching may be conducted from one side of flat sheet 420 or from both sides of flat sheet 420, either concurrently or serially. Where etching is effected from both sides of flat sheet 420, the resulting

- 69 -

cross-sectional shape of the elastic filament may somewhat resemble a hexagon.

As a general rule, the etching process requires the provision of a space between the "solid" portions
5 (i.e., the filament runs) of the device, where this space is approximately equal to the thickness of the flat sheet 420.

In one preferred form of the invention, flat sheet 420 is approximately 0.004 inch thick. In
10 another form of the invention, flat sheet 420 is approximately 0.0053 inch thick.

Electro-polishing.

As noted above, electro-polishing is a "reverse plating" process which electrochemically removes
15 material. It preferentially takes material away from sharp corners, where the electrical fields are the strongest. Rounding sharp corners is believed to be beneficial for the present invention, since it provides a gentle radius where the device touches
20 tissue, and it reduces stress concentrations in the elastic filament. In addition, the rounding of corners will tend to bring the cross-section of the elastic filament to a near-circular shape, which will tend to increase ease of bending in any direction.

25 Electro-polishing removes material thickness as well. As a simple rule of thumb, electro-polishing creates about a 2x corner radius for a 1x decrease in material thickness. As a result, a 0.0005 inch

- 70 -

thickness decrease results in a 0.001 inch radius on an outside corner.

Figs. 126, 128 and 130 are views showing electro-polishing to 0.00415 inch thick, and Figs. 127, 129
5 and 131 are views showing electro-polishing to 0.0039 inch thick.

Electro-polishing can also change the surface properties of the shape memory material. By way of example but not limitation, flat sheet 420 typically
10 has machining marks and other marks from the Nitinol sheet fabrication process. These marks may be minimized or diminished in the electro-polishing process.

Electro-polishing can also change the surface
15 finish of the device. Generally, the electro-polishing smooths the surface and makes it more corrosion resistant.

Tailoring The Cross-Section Of The Device.

It should be appreciated that the cross-section
20 of the device can affect the mechanical properties of the device when the device is subjected to various forces. By way of example but not limitation, where the device has a round cross-section, the device will tend to bend equally well in all directions when the
25 bend occurs at that cross-section. By way of further example but not limitation, where the device has a rectangular cross-section, the device will tend to bend preferentially in certain directions when the

- 71 -

bend occurs at that cross-section. Accordingly, in one form of the present invention, the device has a cross-section which is intentionally varied along its length in accordance with the mechanical properties desired for various segments of the device.

It will be appreciated that a desired cross-section can be achieved by appropriately selecting and implementing a specific manufacturing process, e.g., where etching is used to form the device, various etching parameters (including masking) can be adjusted so as to form a desired cross-section, and/or where electro-polishing is used to form the device, various electro-polishing parameters (including masking) can be adjusted so as to form a desired cross-section, etc.

Forming The Final Three-Dimensional Structure From The Two-Dimensional Interim Structure.

As noted above, the present invention comprises transforming the two-dimensional interim structure 425 (Fig. 110) into the final three-dimensional structure 435 (Fig. 111). As this transformation occurs, the spacing between the filament lengths (i.e., runs) of the two-dimensional structure 425 is reduced in the three-dimensional structure 420. This is because the filament lengths move closer together as the device transforms from a two-dimensional structure to a three-dimensional structure (e.g., as the filament lengths move from a planar arrangement to a spherical

- 72 -

arrangement). As result, the design must provide
adequate space between the filament lengths in the
two-dimensional structure so as to permit appropriate
spacing of the filament lengths in the three-
5 dimensional structure.

Modifications

It will be appreciated that still further
embodiments of the present invention will be apparent
10 to those skilled in the art in view of the present
disclosure. It is to be understood that the present
invention is by no means limited to the particular
constructions herein disclosed and/or shown in the
drawings, but also comprises any modifications or
15 equivalents within the scope of the invention.

- 73 -

What Is Claimed Is:

1. A method for making a device for causing thrombosis of an aneurysm, wherein said device
5 comprises a single elastic filament configurable between (i) an elongated, substantially linear configuration, and (ii) a longitudinally-contracted, substantially three-dimensional configuration, said method comprising:

10 providing a sheet of shape memory material;
producing a single filament, two-dimensional interim structure from said sheet of shape memory material;

15 mounting said single filament, two-dimensional interim structure to a fixture so that said single filament, two-dimensional interim structure is transformed into said longitudinally-contracted, substantially three-dimensional configuration; and

20 heat treating said single filament, two-dimensional interim structure while it is mounted to said fixture so as to produce said device in its longitudinally-contracted, substantially three-dimensional configuration.

25 2. A method according to claim 1 wherein said single filament, two-dimensional interim structure is produced from said sheet of shape memory material by etching.

- 74 -

3. A method according to claim 1 wherein said
single filament, two-dimensional interim structure is
produced from said sheet of shape memory material by
5 laser cutting.

4. A method according to claim 1 further
comprising the step of electro-polishing said single
filament, two-dimensional interim structure before it
10 is mounted to said fixture.

5. A method according to claim 4 wherein said
step of electro-polishing said single filament, two-
dimensional interim structure is performed while said
15 single filament, two-dimensional interim structure is
still attached to said sheet of shape memory material.

6. A method according to claim 1 wherein said
fixture comprises a three-dimensional body.
20

7. A method according to claim 6 wherein said
three-dimensional body comprises surface features for
releasably retaining said single filament, two-
dimensional interim structure on said three-
25 dimensional body.

- 75 -

8. A method according to claim 7 wherein said surface features comprise posts mounted to said three-dimensional body.

5 9. A method according to claim 1 wherein said fixture comprises a two part fixture comprising a male half and a female half.

10 10. A method according to claim 9 wherein said male half of said fixture comprises surface features for releasably retaining said single filament, two-dimensional interim structure on said male half of said fixture.

15 11. A method according to claim 9 wherein said surface features comprise posts mounted to said male half of said fixture.

20 12. A method according to claim 1 wherein said step of heat treating comprises heating followed by quenching.

25 13. A method according to claim 1 wherein said single filament, two-dimensional interim structure comprises a continuous closed loop.

- 76 -

14. A method according to claim 1 wherein said single filament, two-dimensional interim structure comprises two distinct ends.

5 15. A method according to claim 14 comprising the additional step of unifying the two distinct ends so as to form a continuous closed loop.

10 16. A method according to claim 15 wherein the two distinct ends are unified by welding.

17. A method according to claim 15 wherein the two distinct ends are unified by banding.

15 18. A method according to claim 1 wherein a plurality of single filament, two-dimensional interim structures are produced from said sheet of shape memory material.

20 19. A method according to claim 1 wherein said single filament, two-dimensional interim structure is temporarily held to said sheet of shape memory material by an attachment tab.

25 20. A method according to claim 19 wherein said single filament, two-dimensional interim structure is released from said sheet of shape memory material by severing said attachment tab.

- 77 -

21. A method according to claim 1 wherein said single filament, two-dimensional interim structure has a width which varies along its length.

5

22. A method according to claim 1 wherein said single filament, two-dimensional interim structure has a thickness which varies along its length.

10

23. A method according to claim 1 wherein said single filament, two-dimensional interim structure has a cross-section which varies along its length.

15

24. A method according to claim 1 wherein said single filament, two-dimensional interim structure comprises a cross-section comprising flat edges.

20

25. A method according to claim 1 wherein said single filament, two-dimensional interim structure comprises a cross-section comprising flat edges and rounded edges.

25

26. A method according to claim 1 wherein said single filament, two-dimensional interim structure comprises a cross-section which is circular.

- 78 -

27. A method according to claim 1 wherein said single filament, two-dimensional interim structure comprises a cross-section which is ovoid.

5 28. A method according to claim 1 wherein said sheet of shape memory material has different material properties in different dimensions, and further wherein said device is fabricated so as to take advantage of the varying material properties of said
10 sheet of shape memory material.

29. A method according to claim 1 wherein the shape memory material is selected from the group consisting of: a nickel titanium alloy, a copper-based
15 alloy, an iron-based alloy, and a shape memory polymer.

30. A method according to claim 29 wherein the nickel titanium alloy comprises nitinol.
20

31. A device for positioning in a blood vessel adjacent to an aneurysm for causing thrombosis of the aneurysm while maintaining substantially normal flow through the blood vessel, said device comprising:
25

a single elastic filament configurable between:
(i) an elongated, substantially linear configuration, whereby to facilitate movement along a blood vessel; and

- 79 -

(ii) a longitudinally-contracted, substantially three-dimensional configuration for lodging within the blood vessel, said longitudinally-contracted, substantially three-dimensional configuration providing (a) a face for positioning adjacent the aneurysm, said face comprising a plurality of lengths of said elastic filament in close proximity to one another so as to restrict blood flow to the aneurysm and thereby cause thrombosis of the aneurysm, and (b) a substantially open frame for holding said face adjacent the aneurysm, said substantially open frame configured so as to maintain substantially normal flow through the blood vessel;

wherein said single elastic filament has a width which varies along its length.

32. A device according to claim 31 wherein said single elastic filament comprises two distinct ends.

33. A device according to claim 31 wherein said single elastic filament comprises a continuous closed loop.

34. A device according to claim 33 wherein the single elastic filament comprises two distinct ends which are unified so as to form a continuous closed loop.

- 80 -

35. A device according to claim 34 wherein the two distinct ends are unified by welding.

5 36. A device according to claim 34 wherein the two distinct ends are unified by banding.

10 37. A method for making a device for causing thrombosis of an aneurysm, wherein said device comprises a single elastic filament configurable between (i) an elongated, substantially linear configuration, and (ii) a longitudinally-contracted, substantially three-dimensional configuration, said method comprising:

15 providing a filament of shape memory material; mounting said filament of shape memory material to a fixture so that said filament is transformed into said longitudinally-contracted, substantially three-dimensional configuration; and

20 heat treating said filament so as to produce said device in its longitudinally-contracted, substantially three-dimensional configuration.

25 38. A method according to claim 37 wherein said fixture comprises a three-dimensional body having surface features for releasably retaining said filament of shape memory material on said three-dimensional body, and further wherein mounting said filament of shape memory material to said fixture

- 81 -

comprises winding said filament of shape memory material around said surface features.

5 39. A method according to claim 38 wherein said surface features comprise posts mounted to said three-dimensional body.

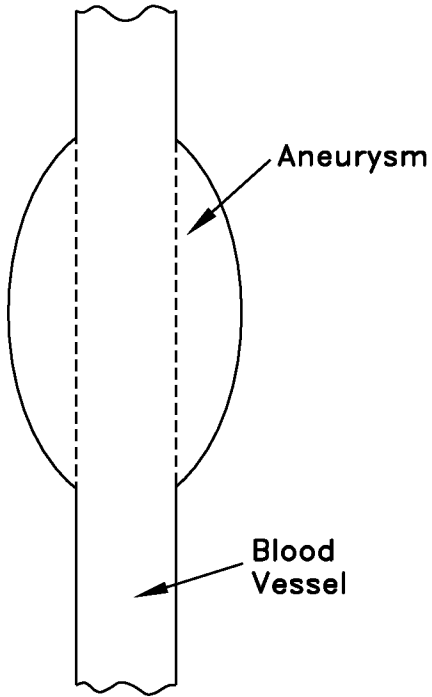

Fusiform Aneurysm

FIG. 1

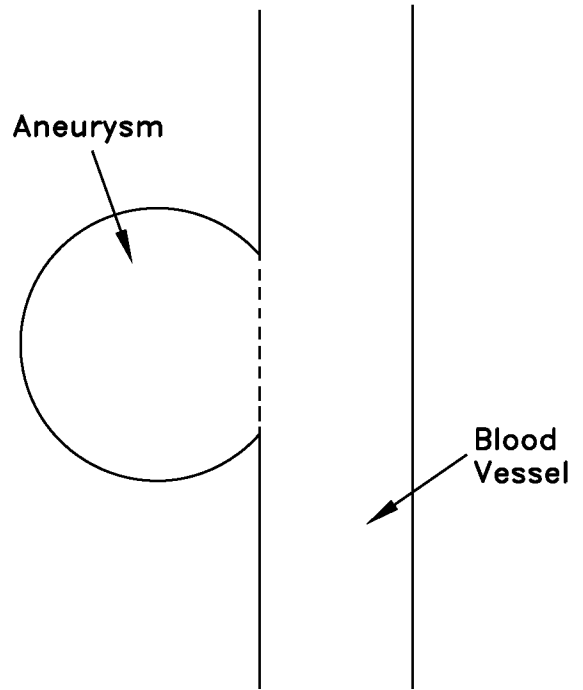

Lateral Aneurysm

FIG. 2

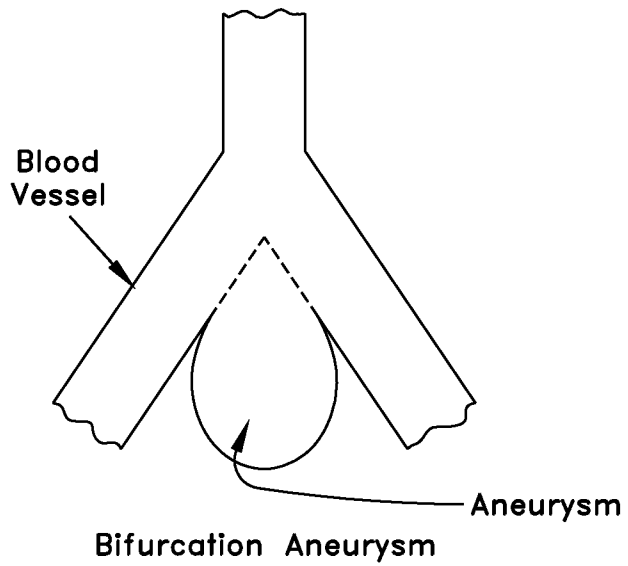

Bifurcation Aneurysm

FIG. 3

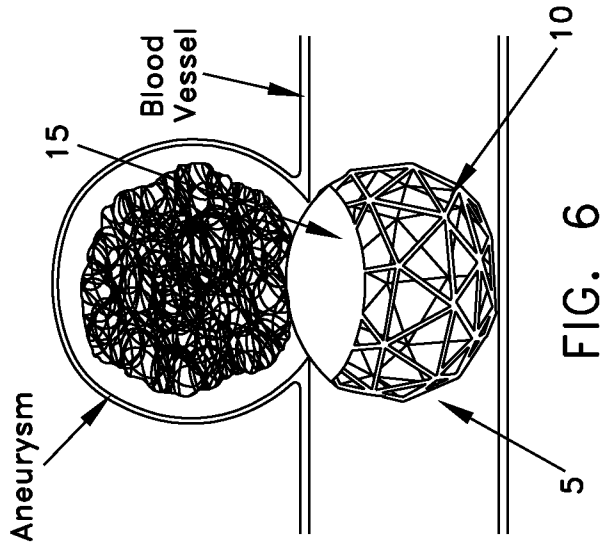

FIG. 6

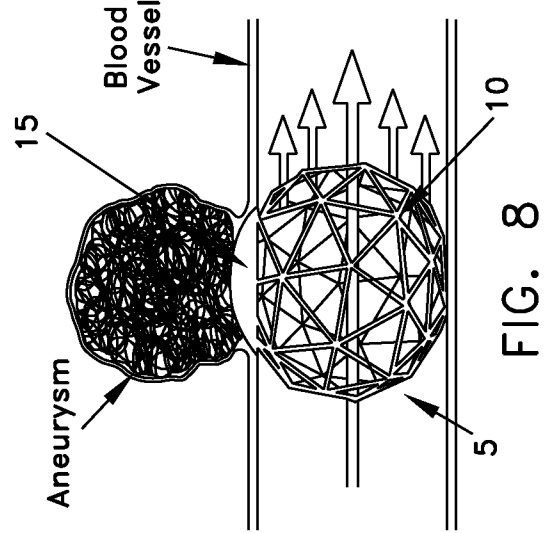

FIG. 8

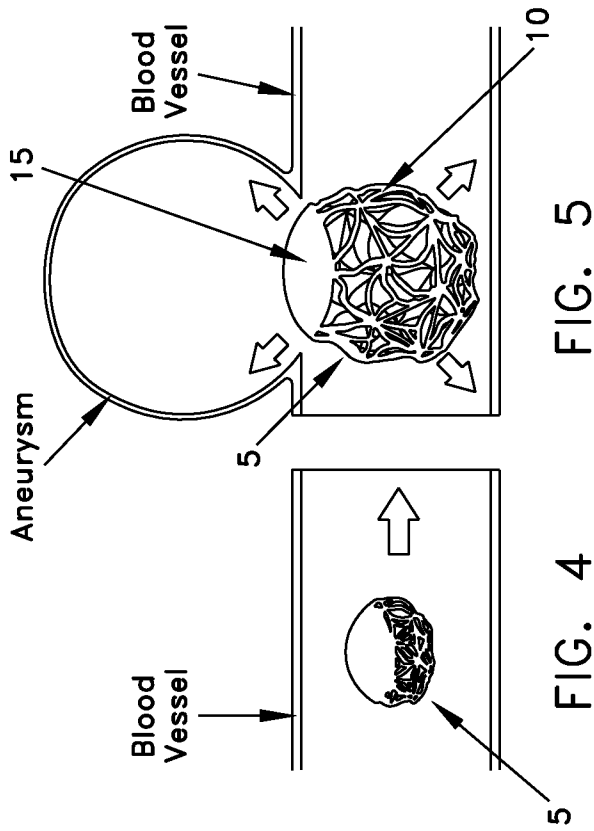

FIG. 5

FIG. 4

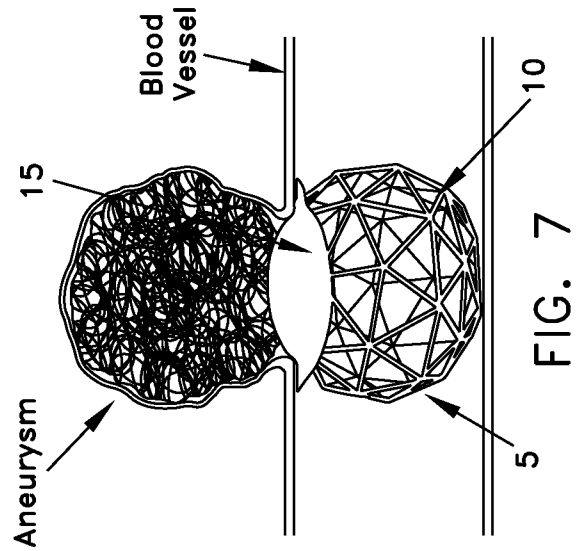

FIG. 7

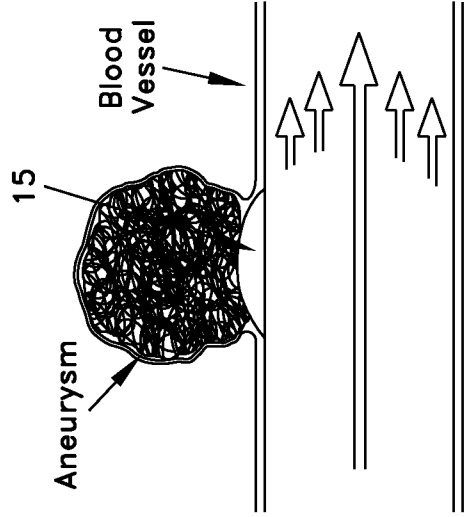
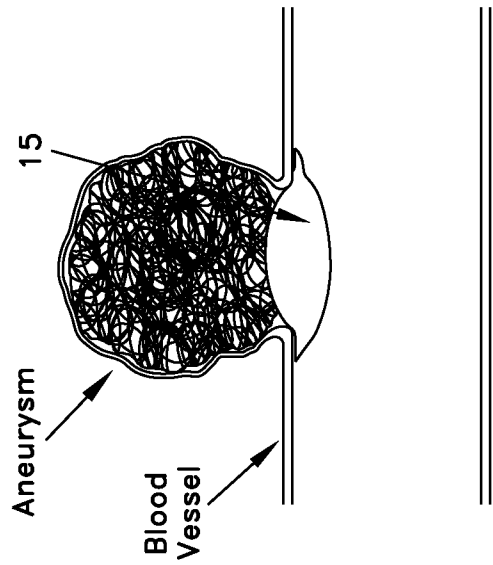
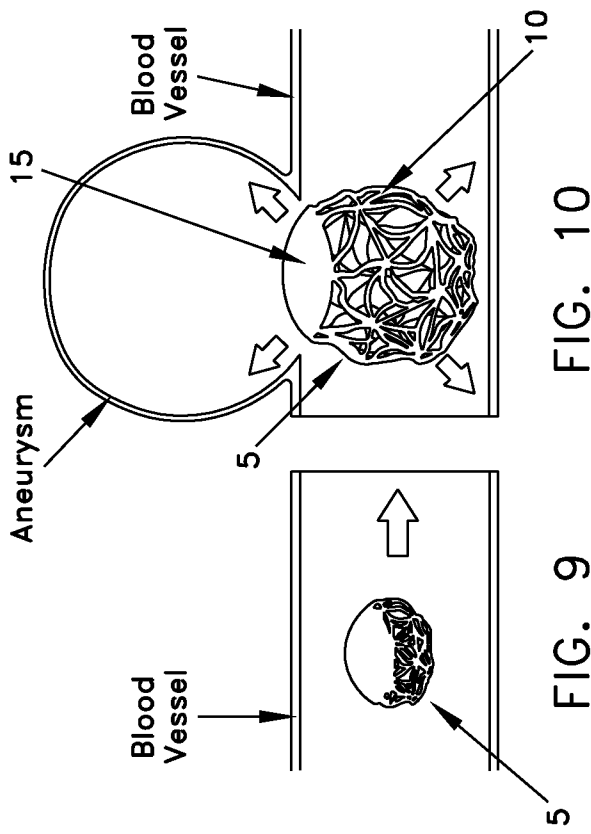
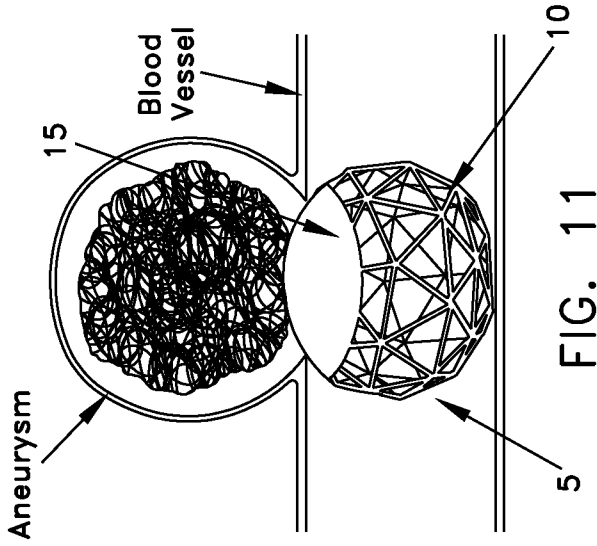

FIG. 13

FIG. 12

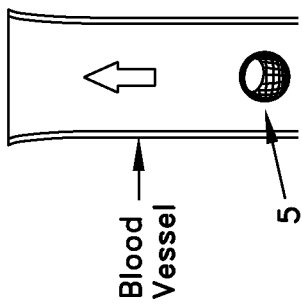

FIG. 14

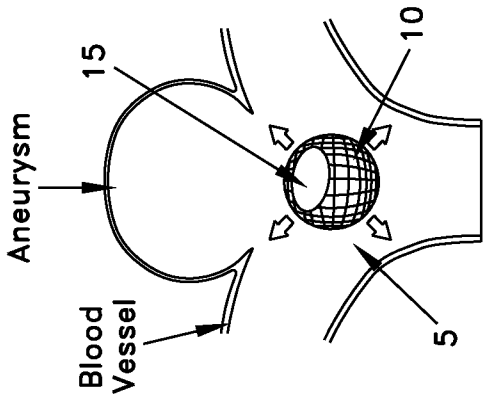

FIG. 15

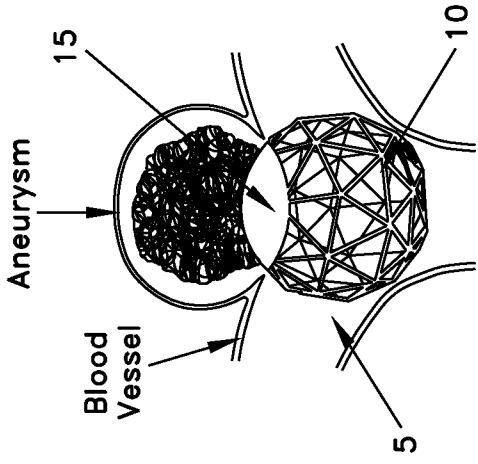

FIG. 16

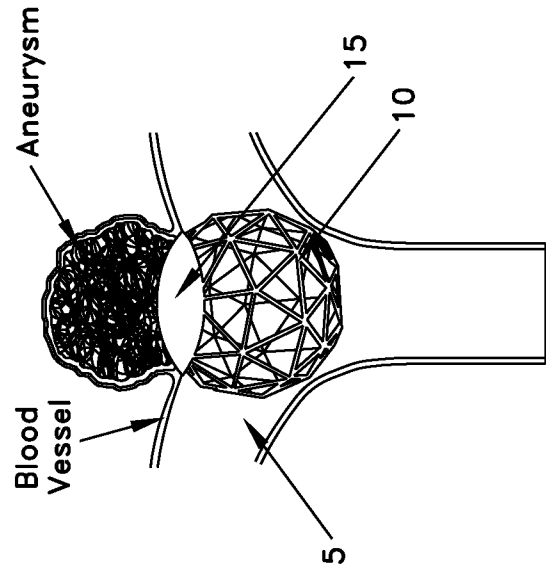

FIG. 17

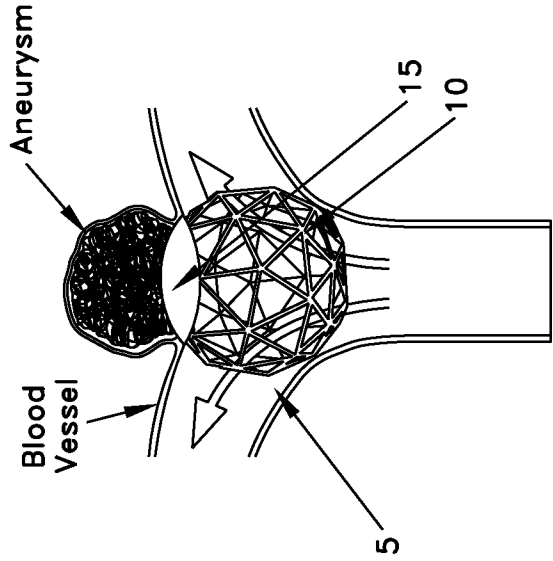

FIG. 18

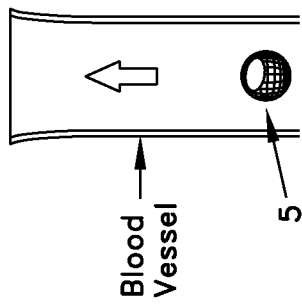

FIG. 19

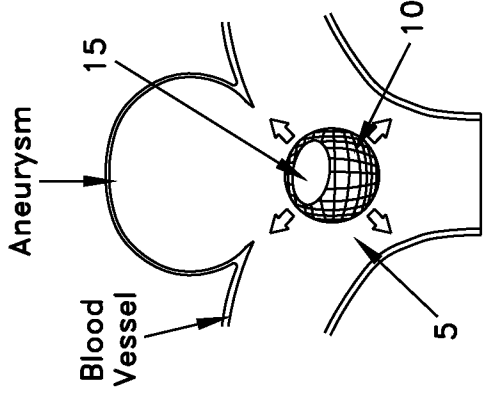

FIG. 20

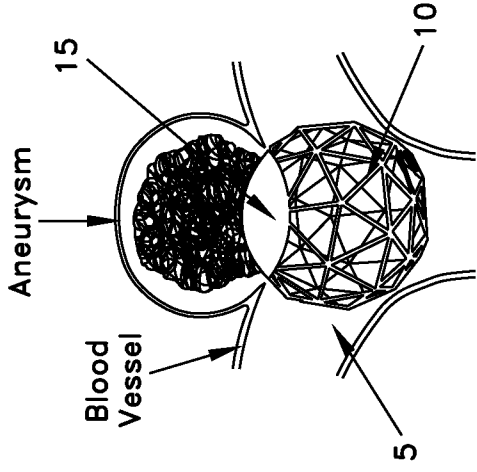

FIG. 21

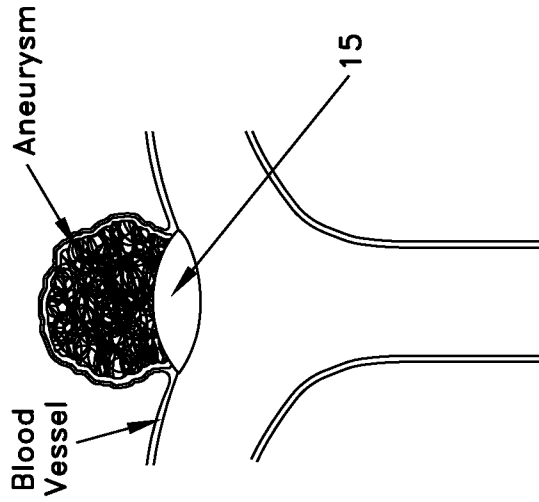

FIG. 22

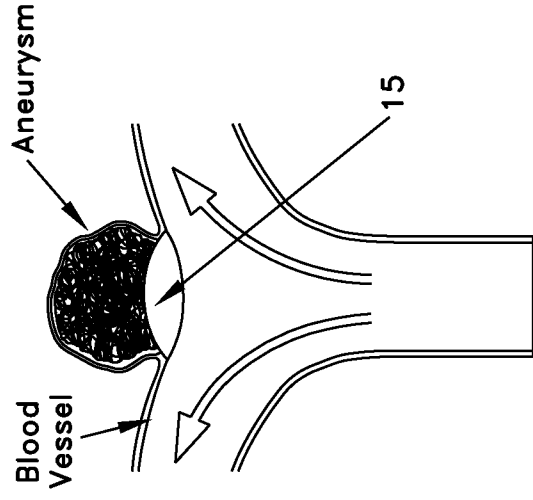

FIG. 23

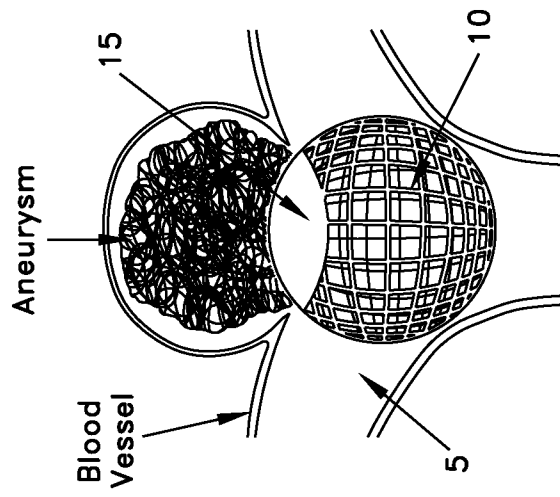

FIG. 24

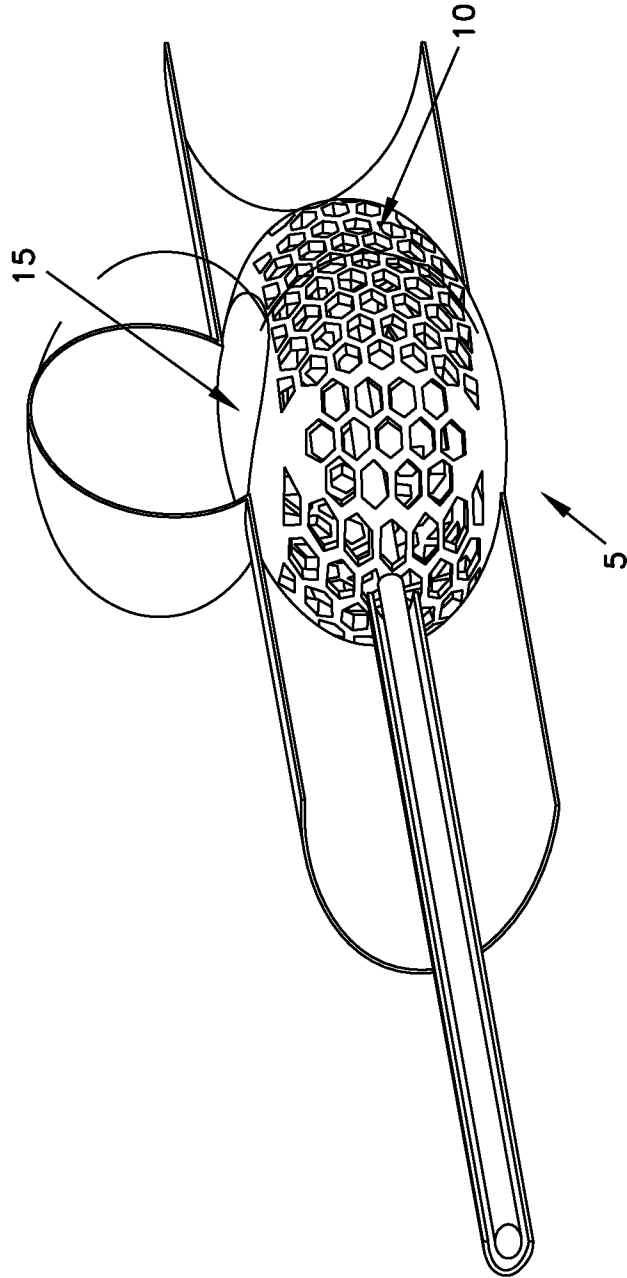

FIG. 25

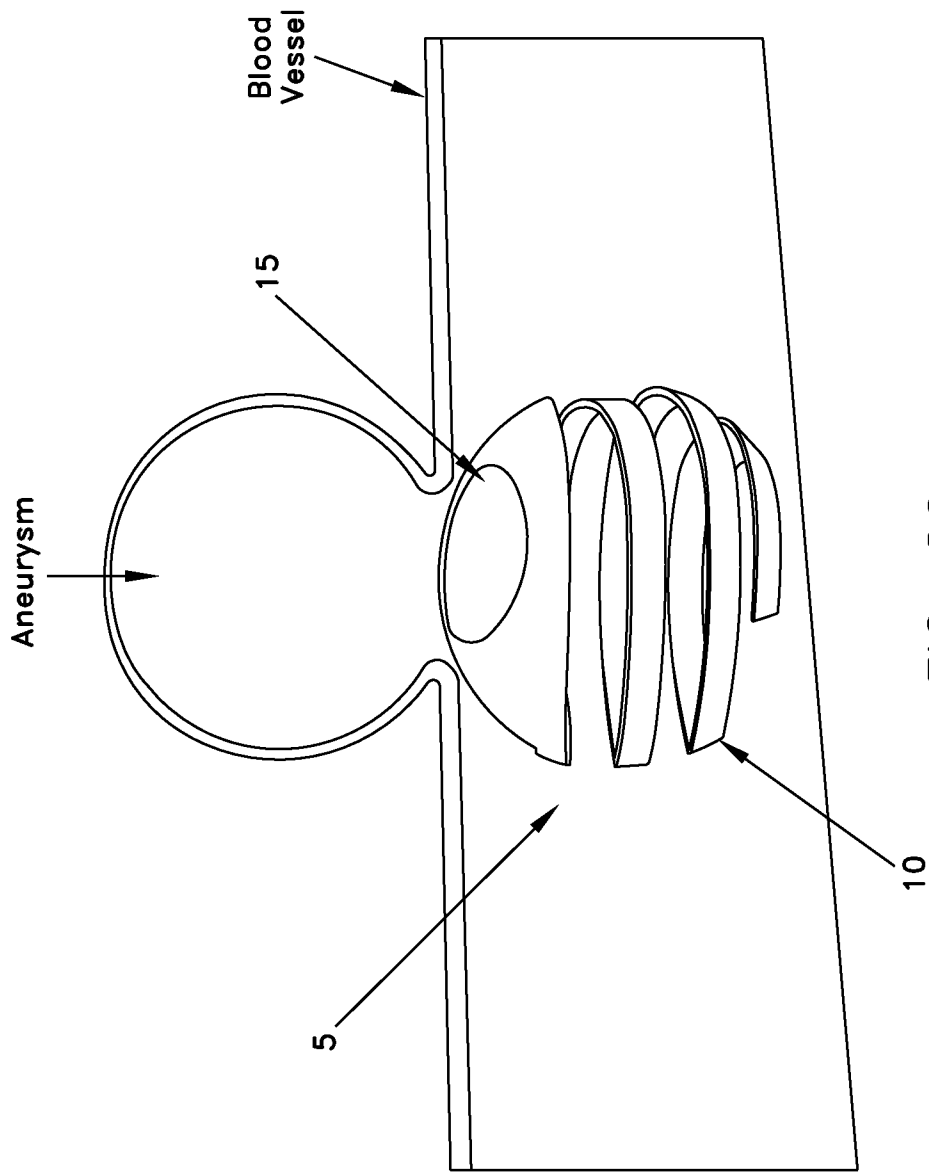

FIG. 26

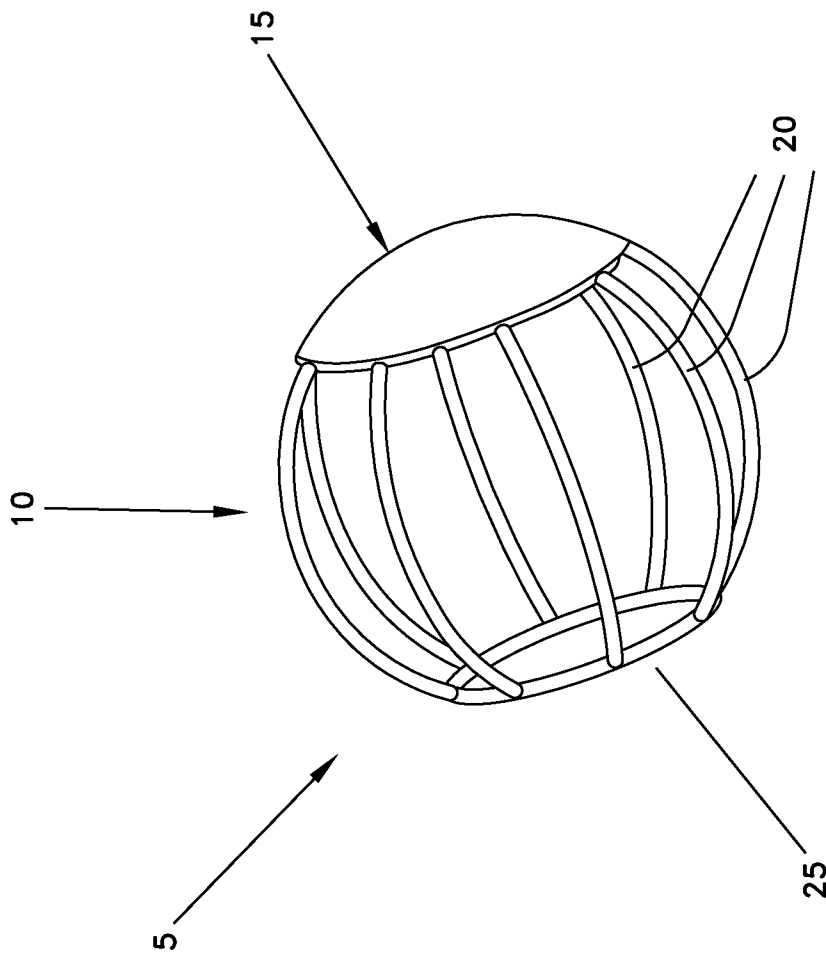

FIG. 27

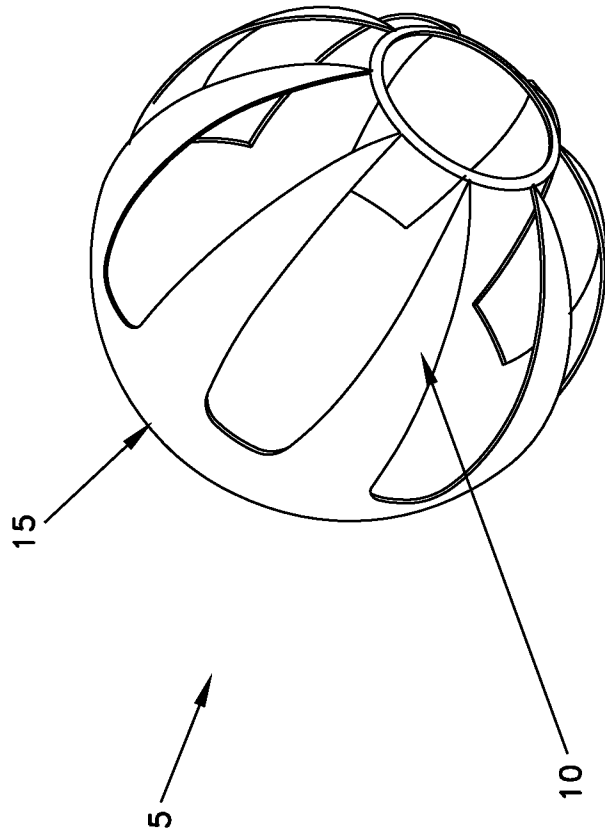

FIG. 28

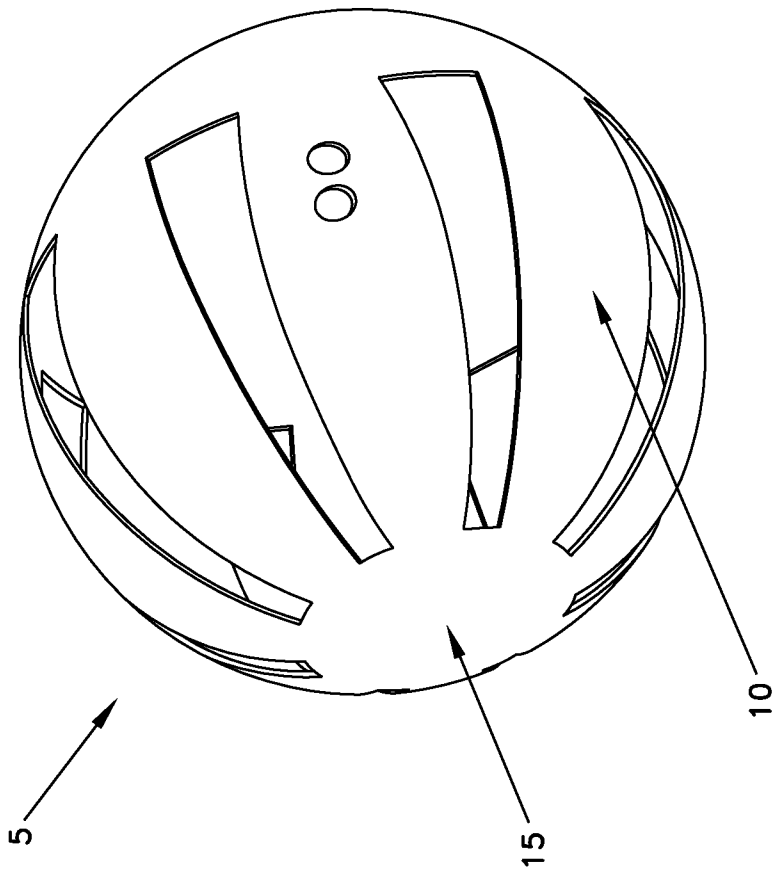

FIG. 29

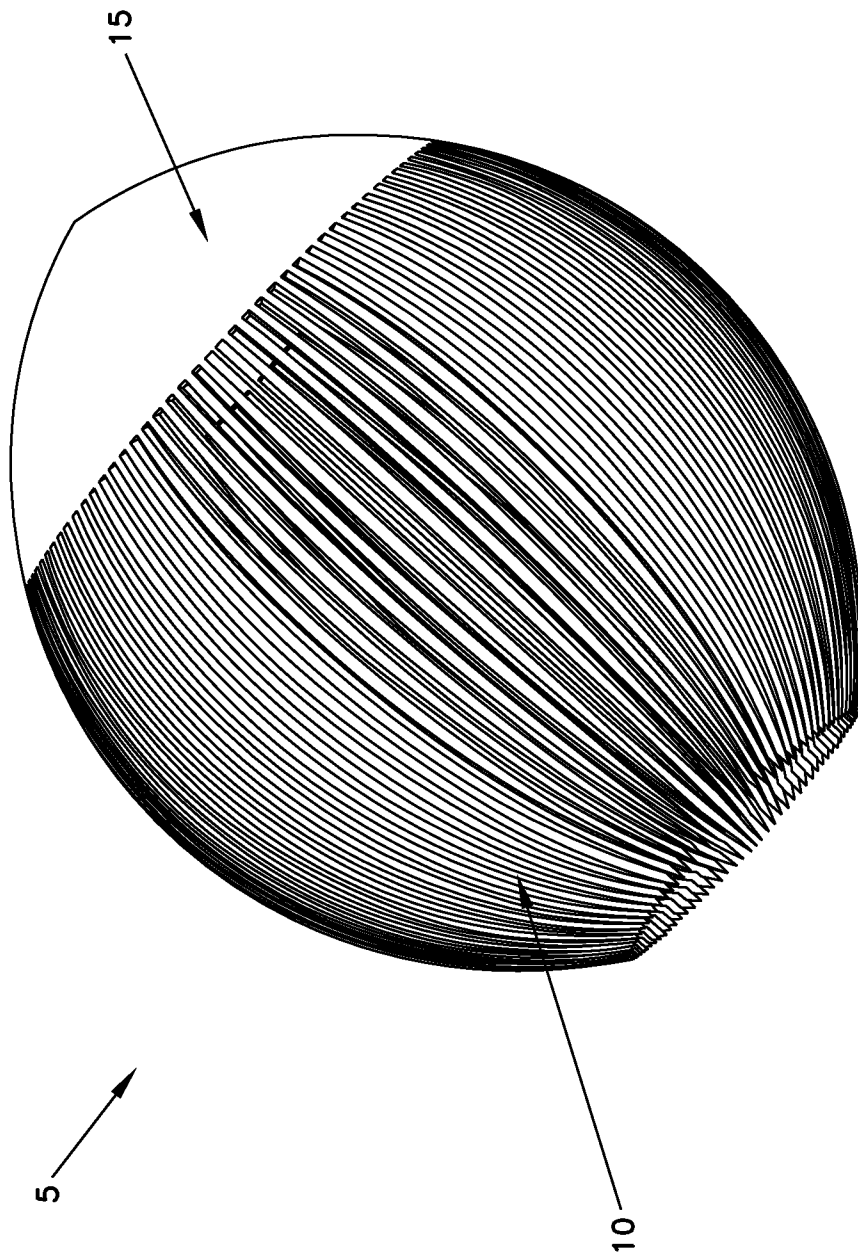

FIG. 30

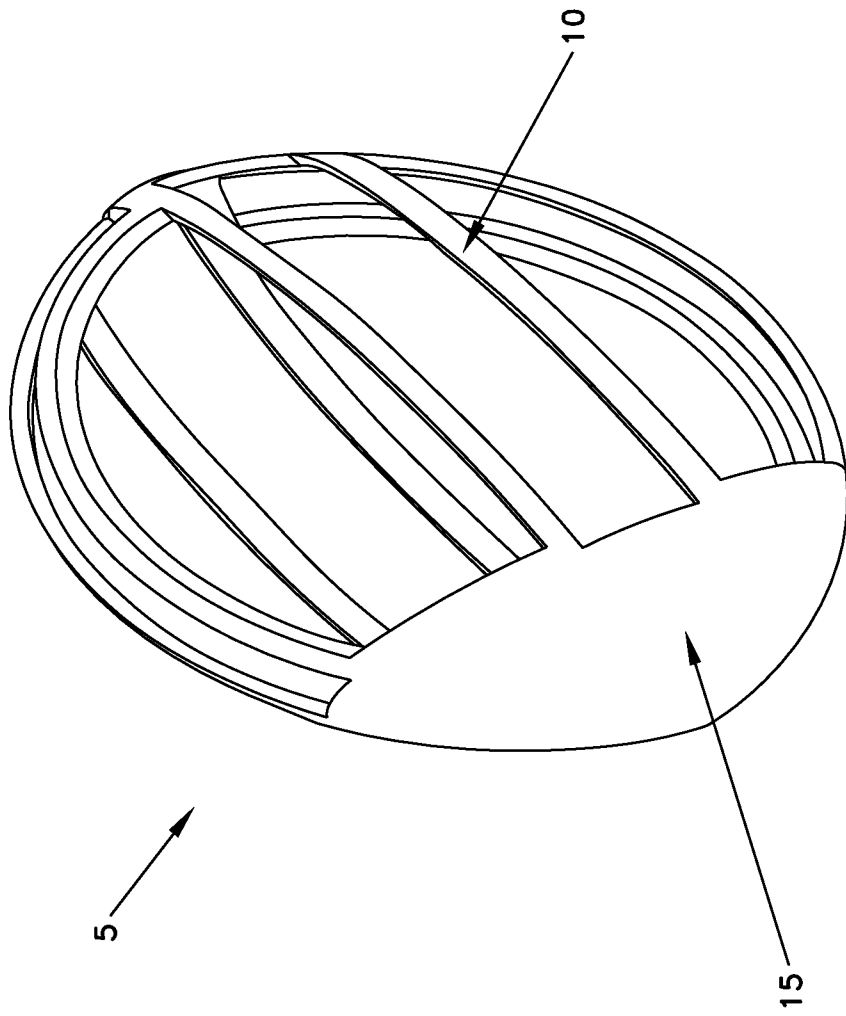

FIG. 31

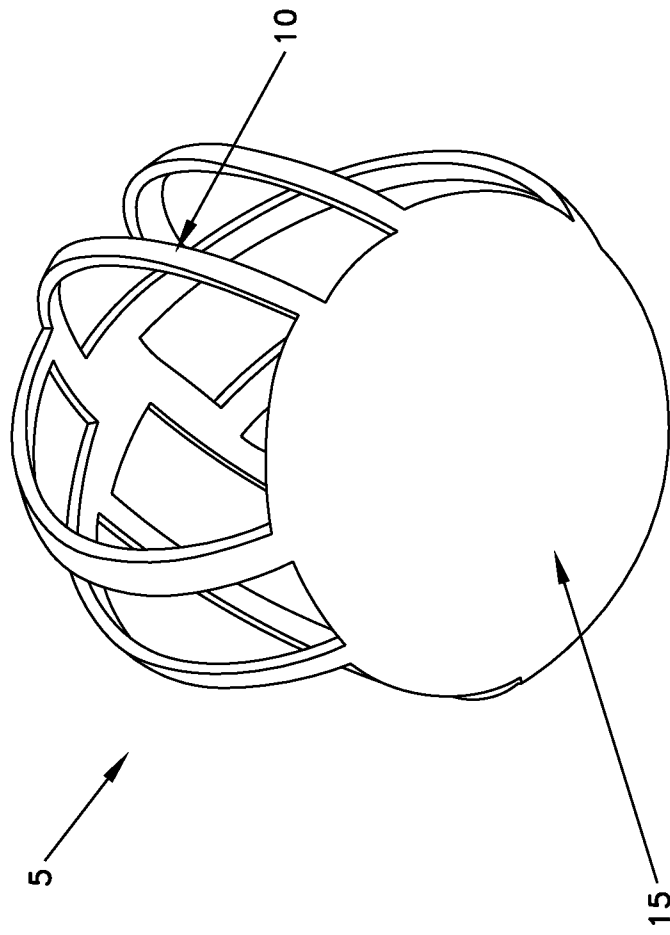

FIG. 32

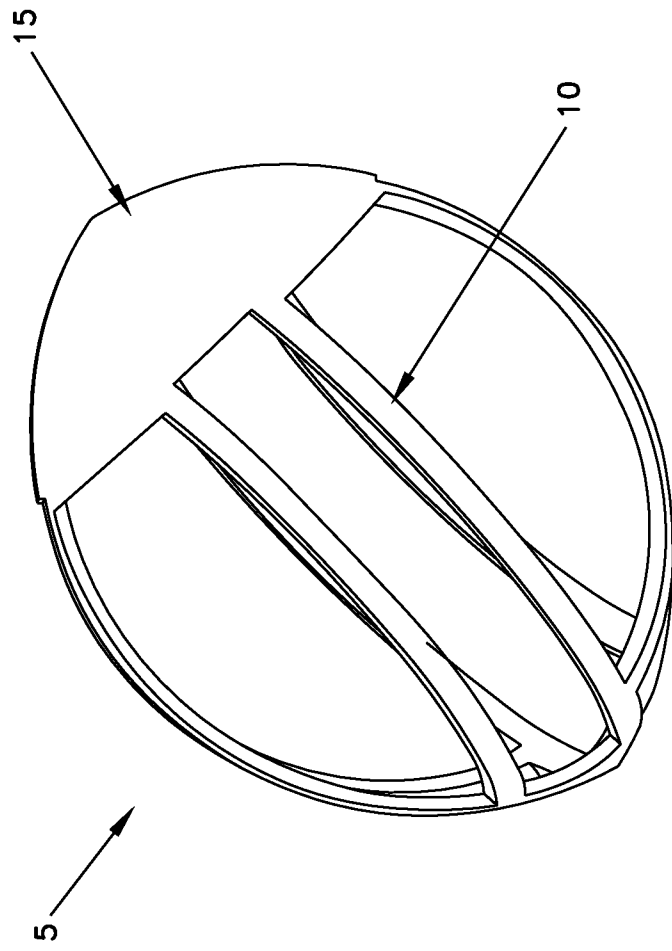

FIG. 33

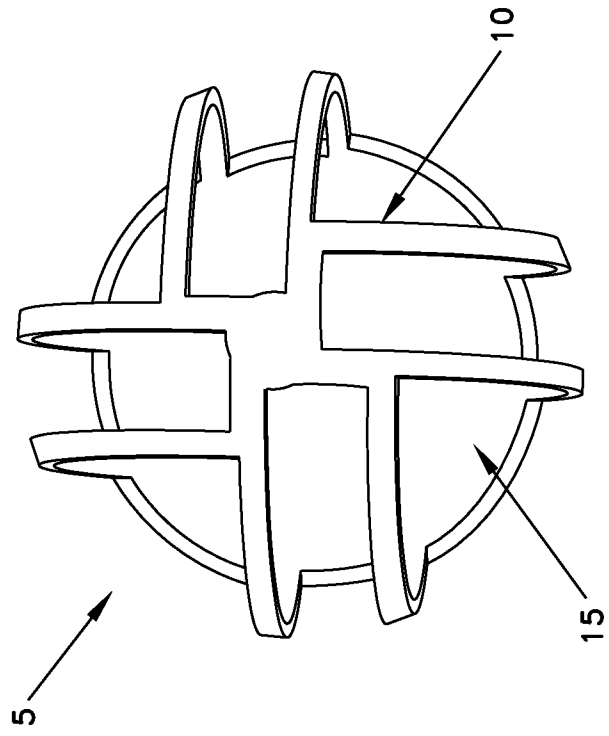

FIG. 34

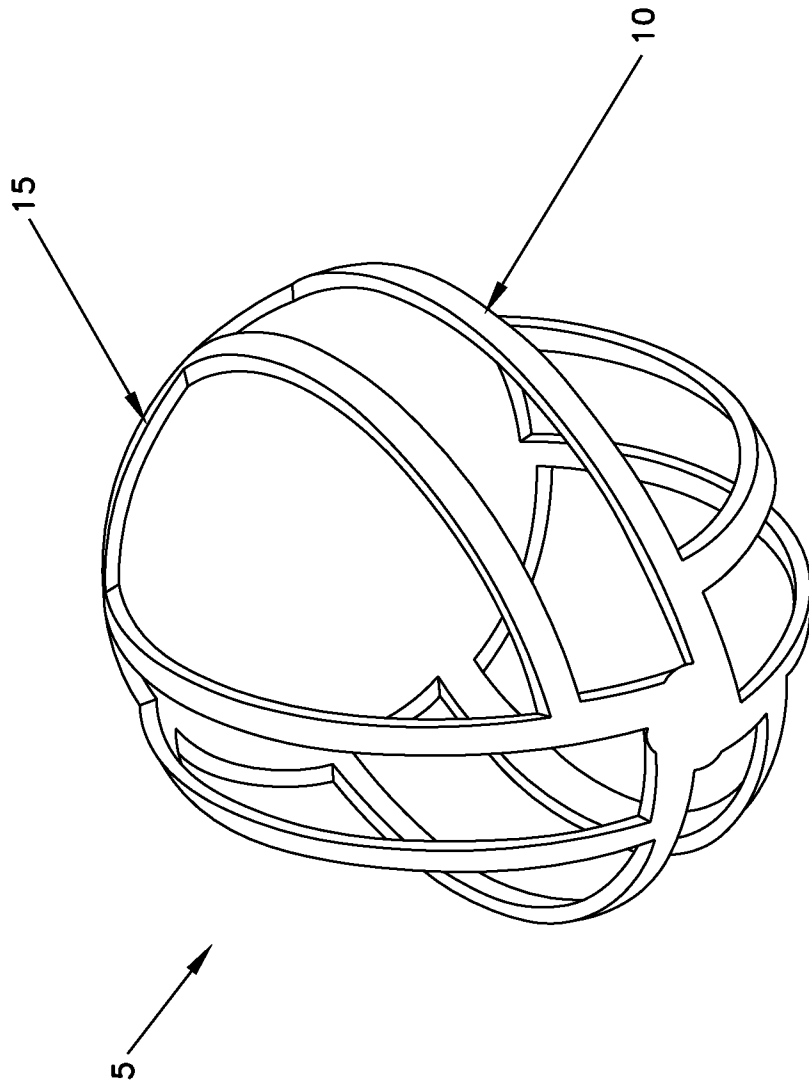

FIG. 35

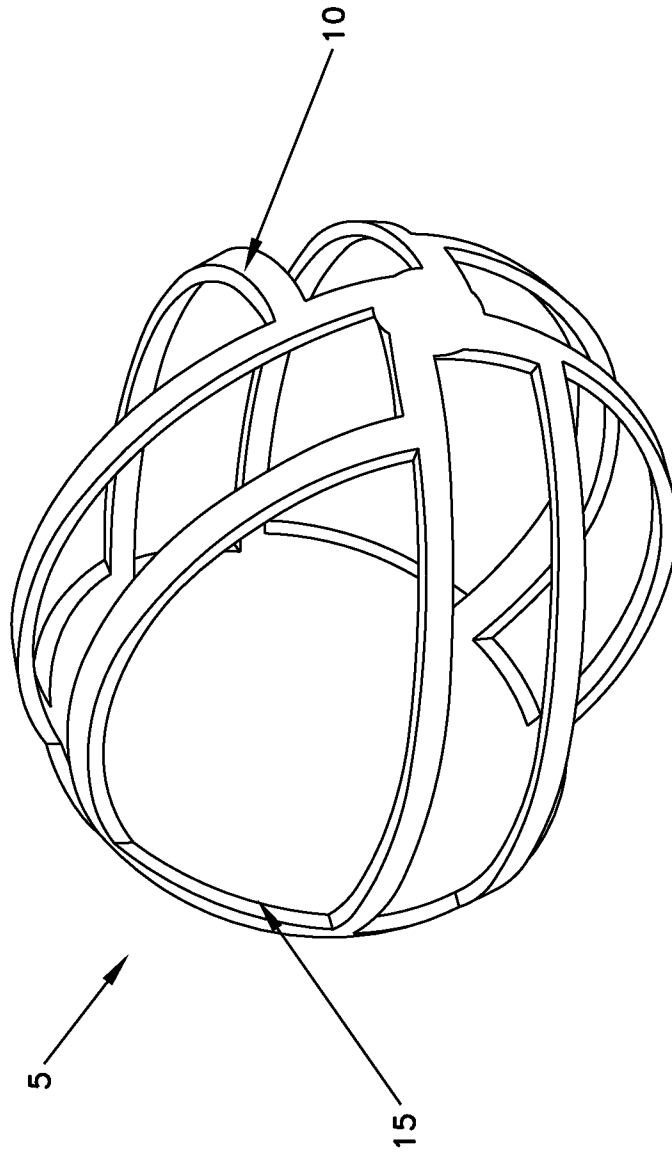

FIG. 36

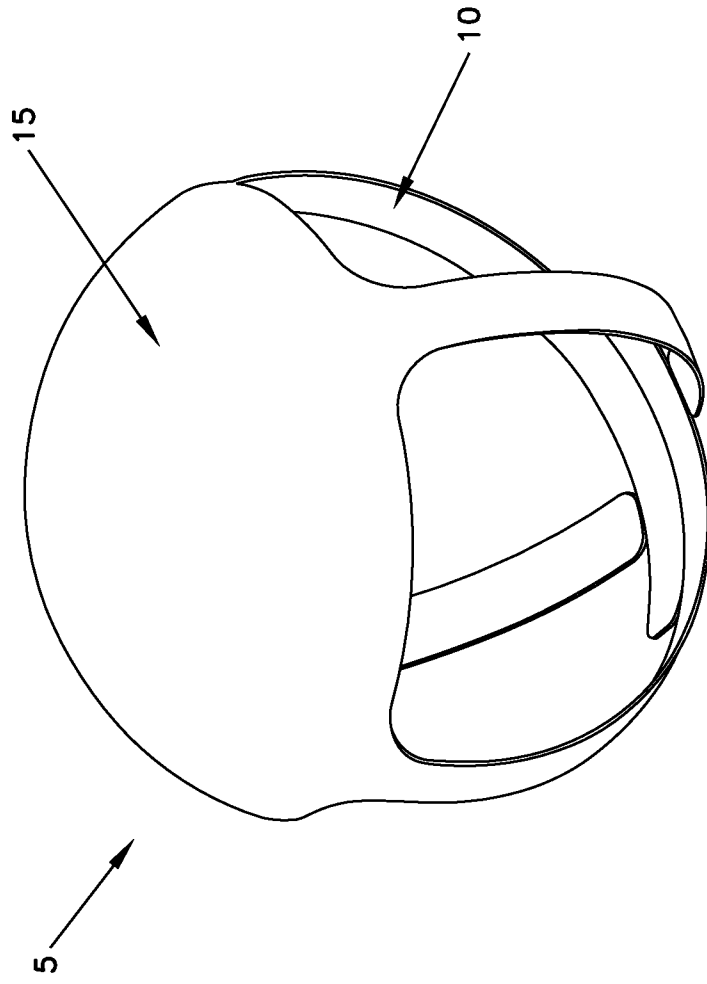

FIG. 37

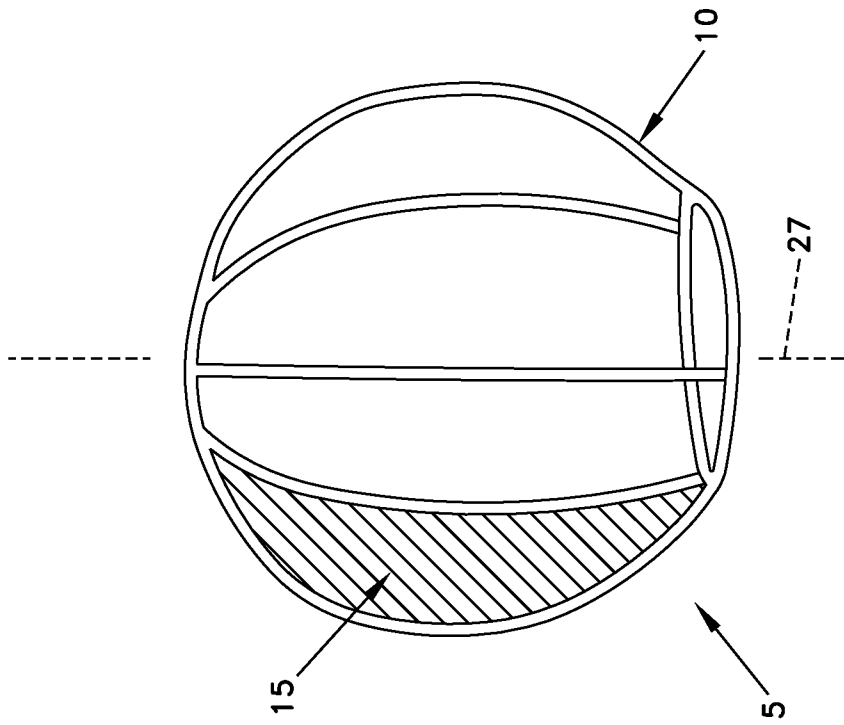

FIG. 38

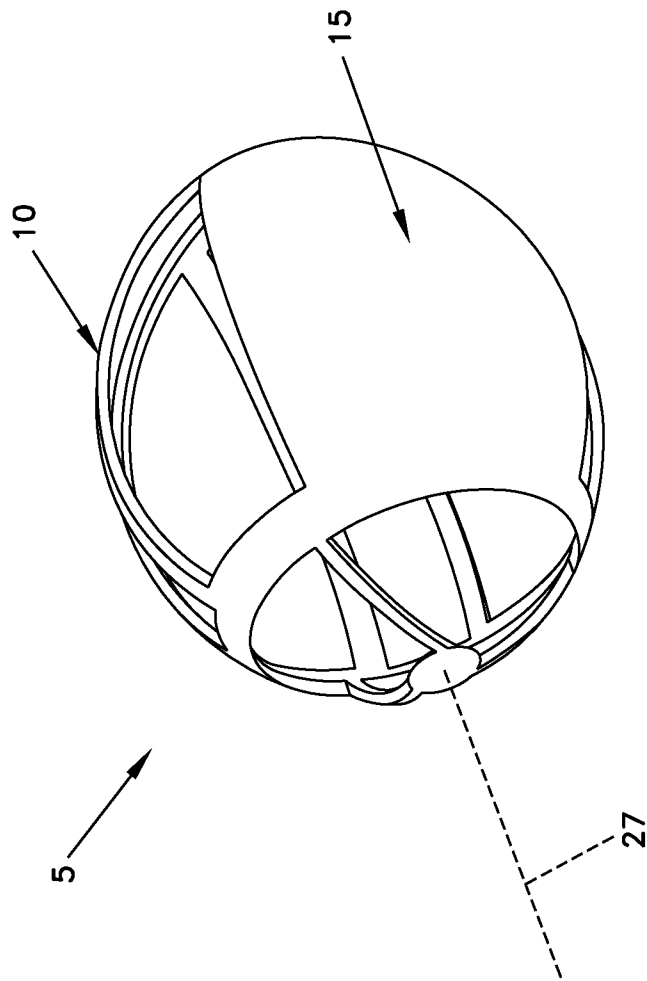

FIG. 39

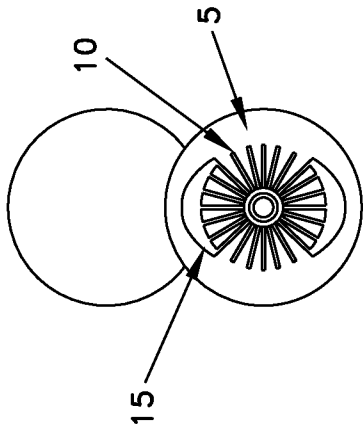

FIG. 41

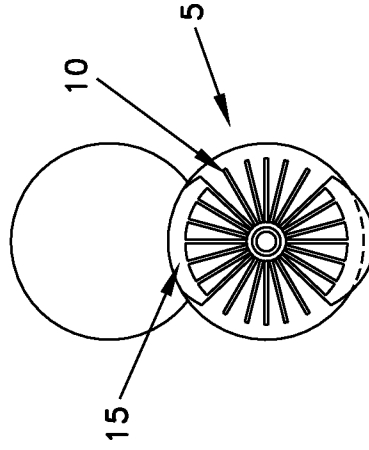

FIG. 43

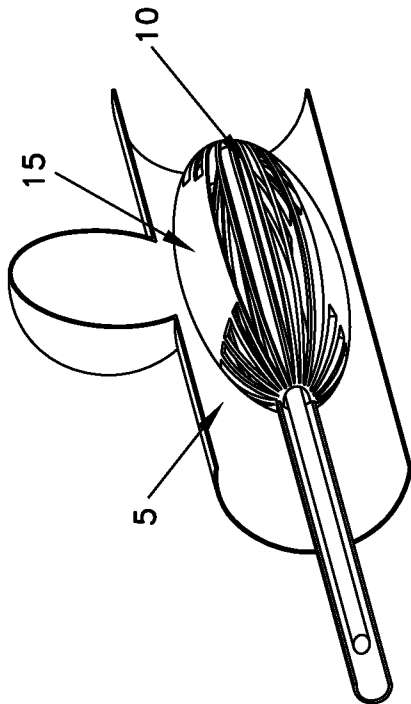

FIG. 40

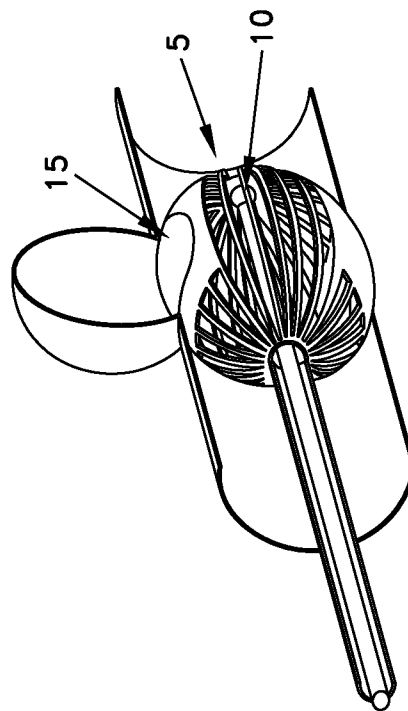

FIG. 42

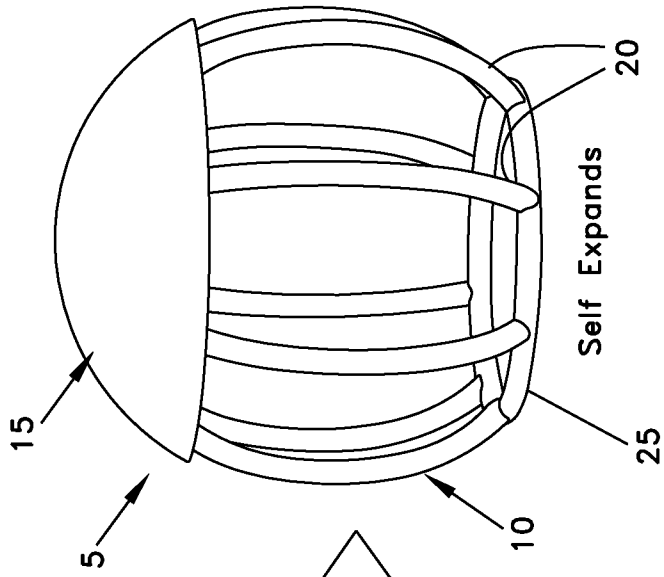

FIG. 45

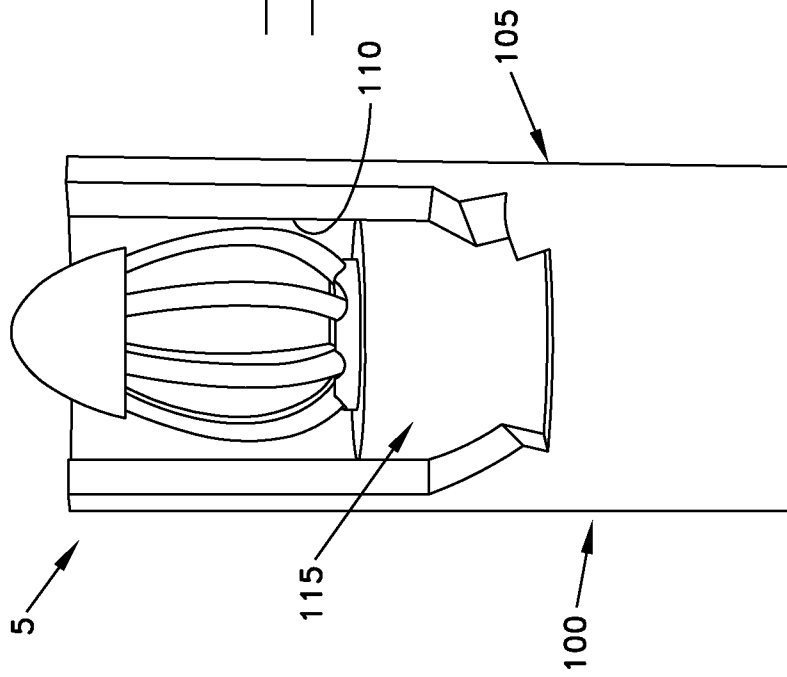

FIG. 44

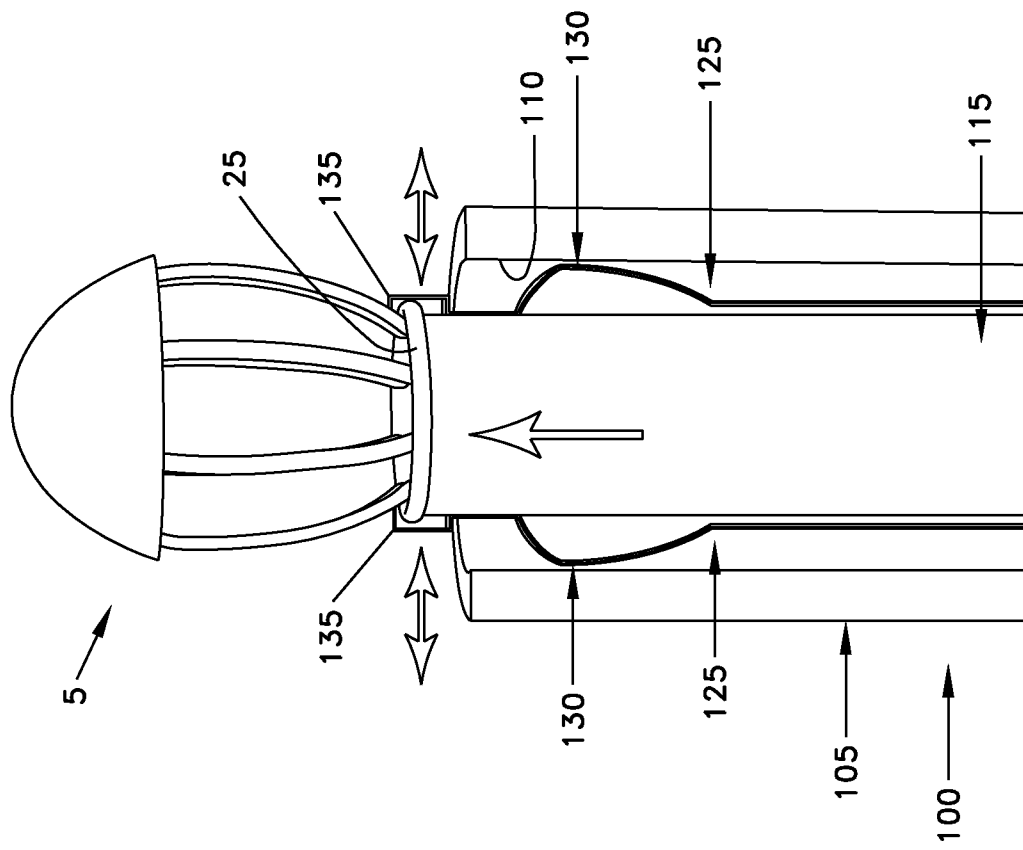

FIG. 46

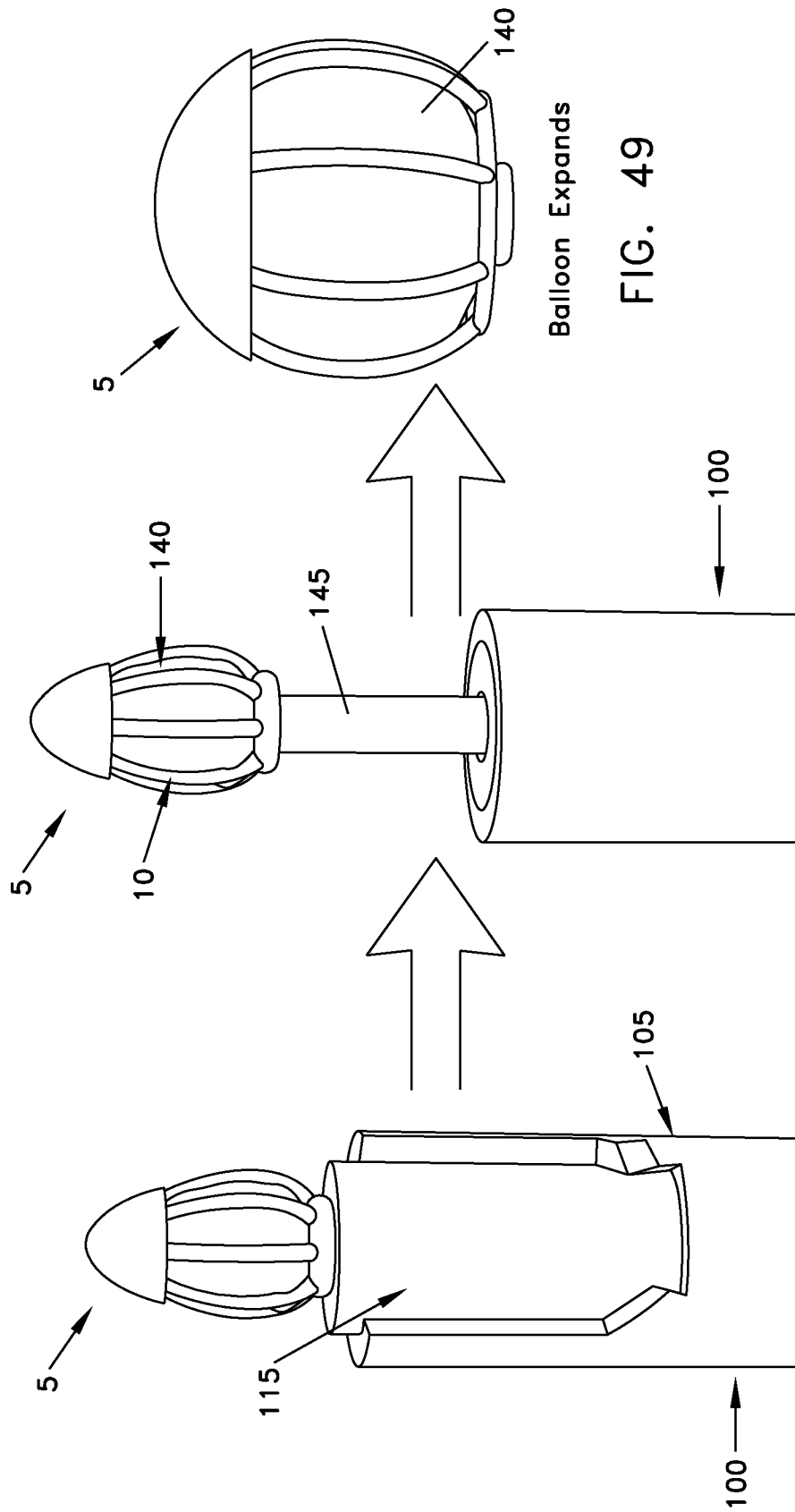

FIG. 48

FIG. 47

FIG. 49

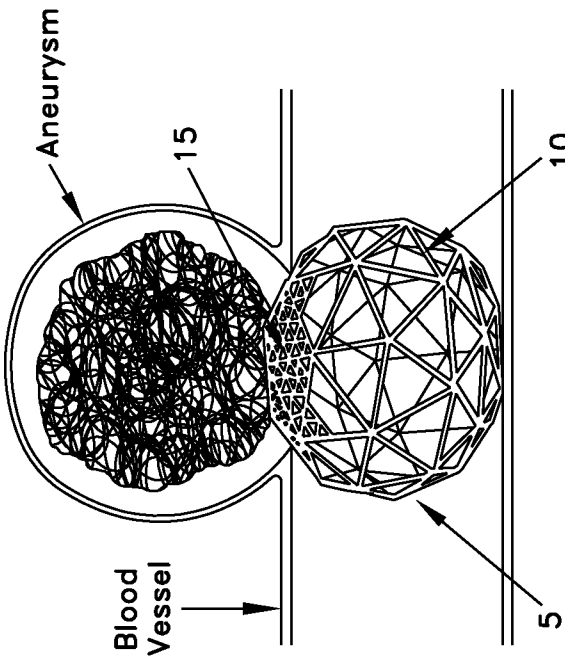

FIG. 50

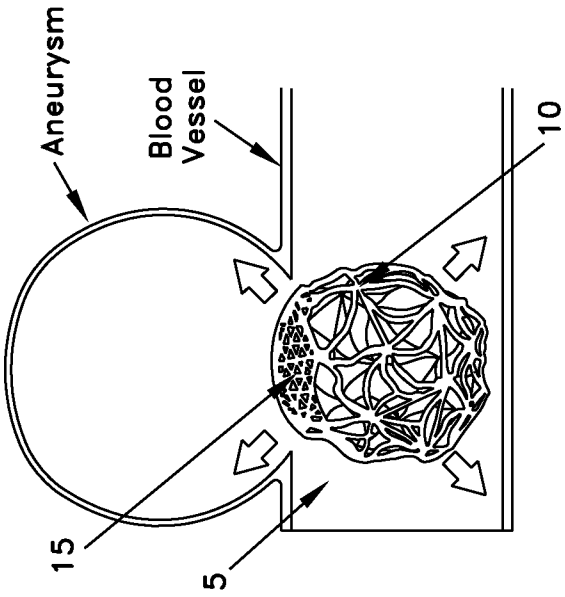

FIG. 51

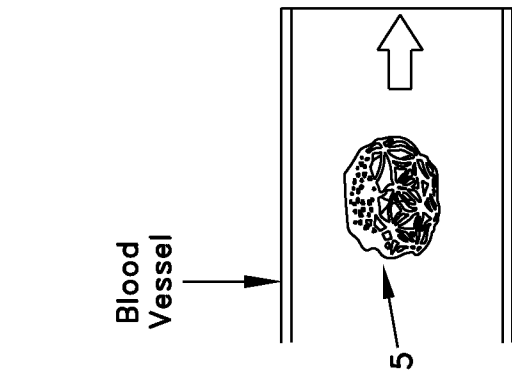

FIG. 52

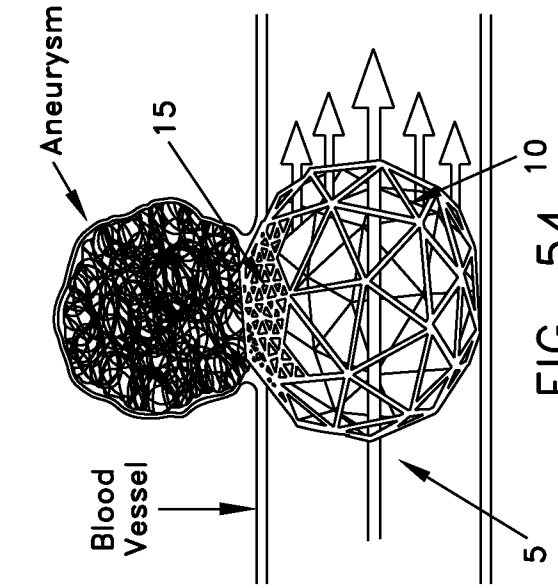

FIG. 53

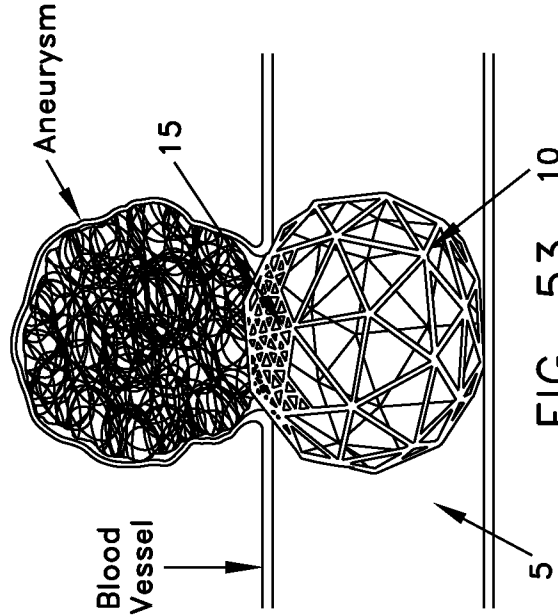

FIG. 54

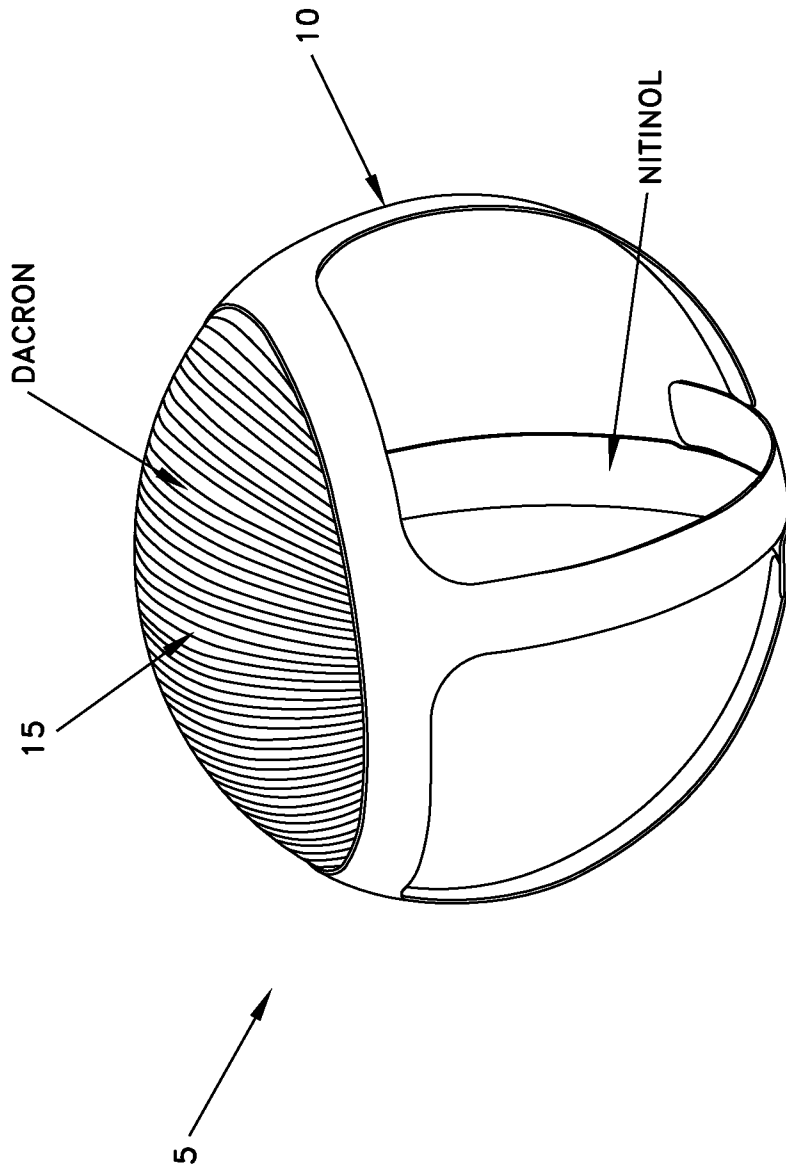

FIG. 55

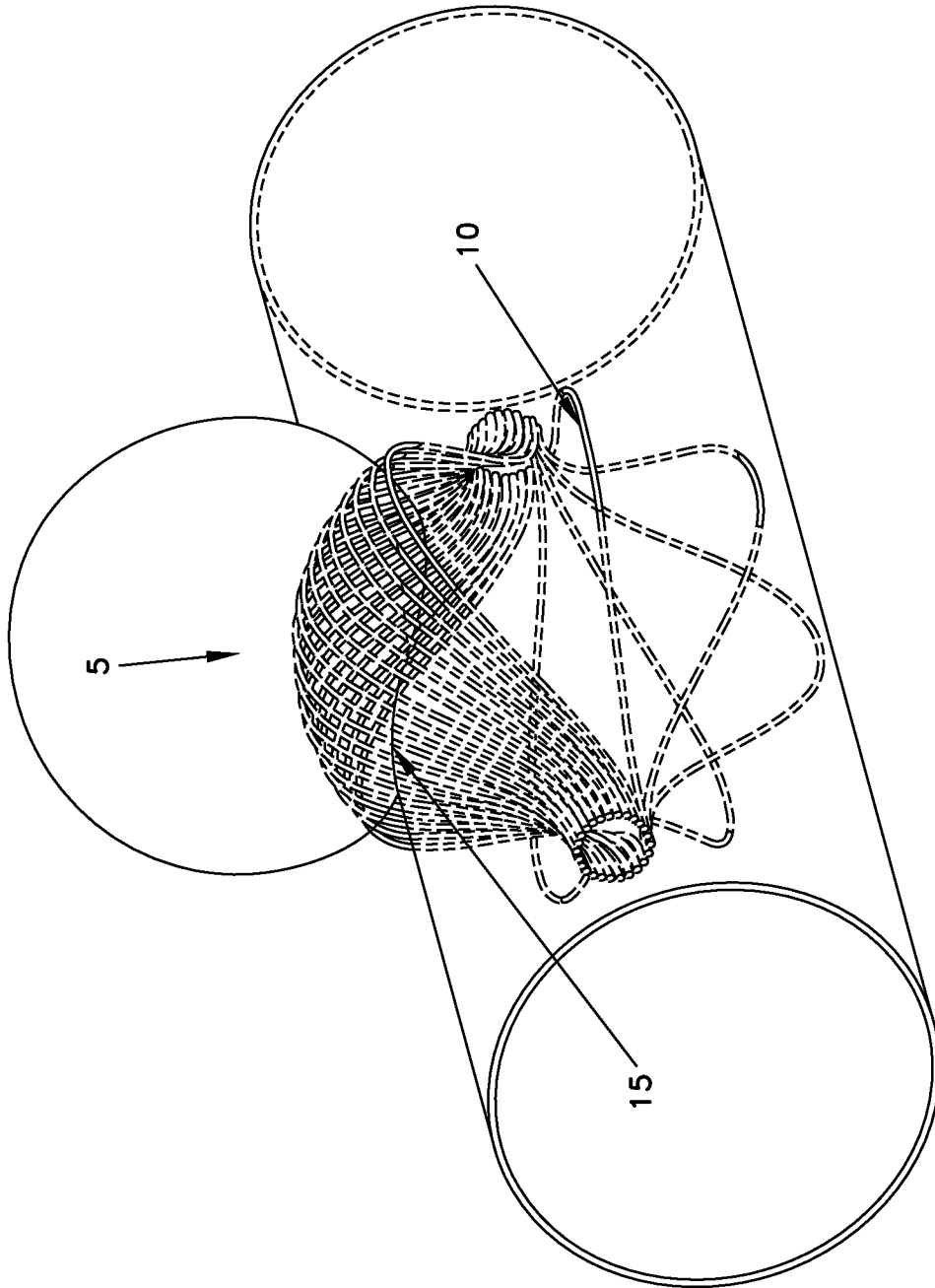

FIG. 56

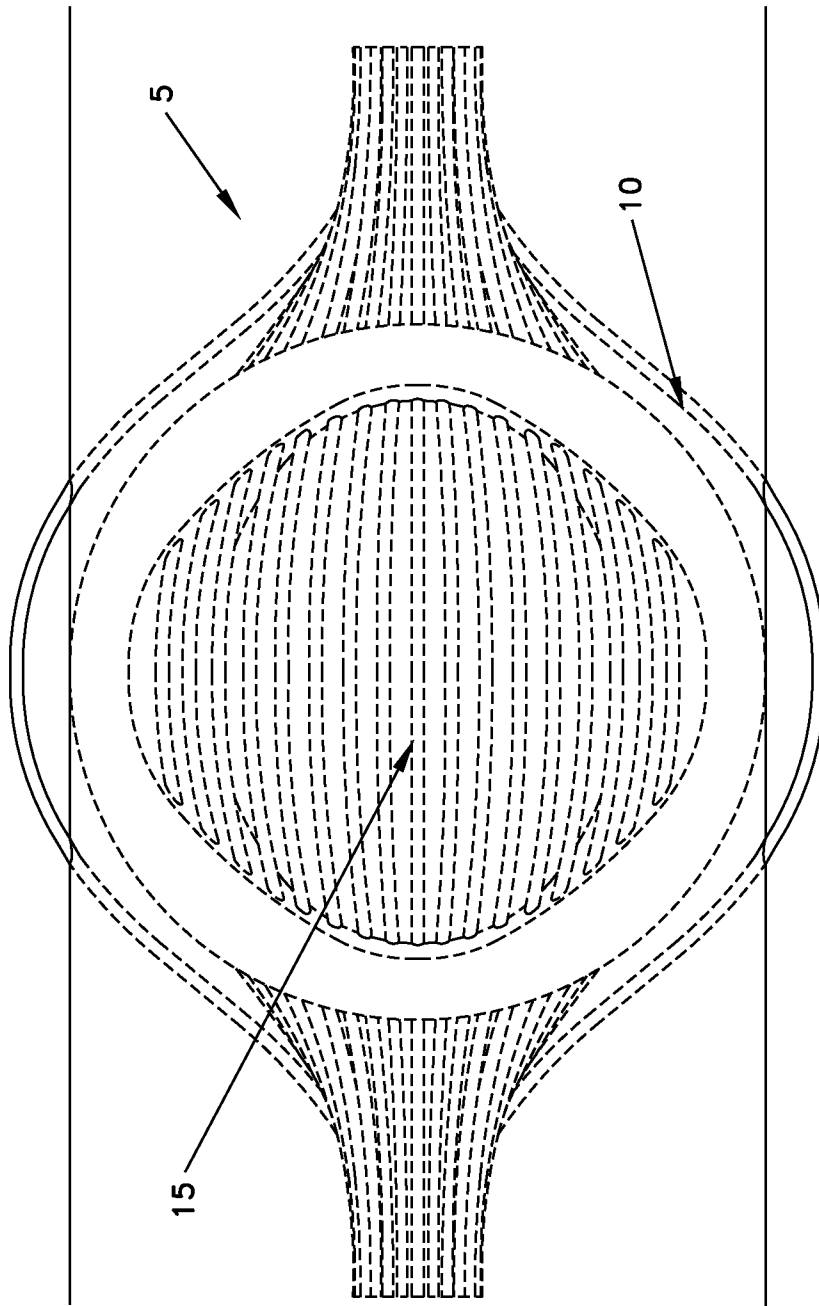

FIG. 57

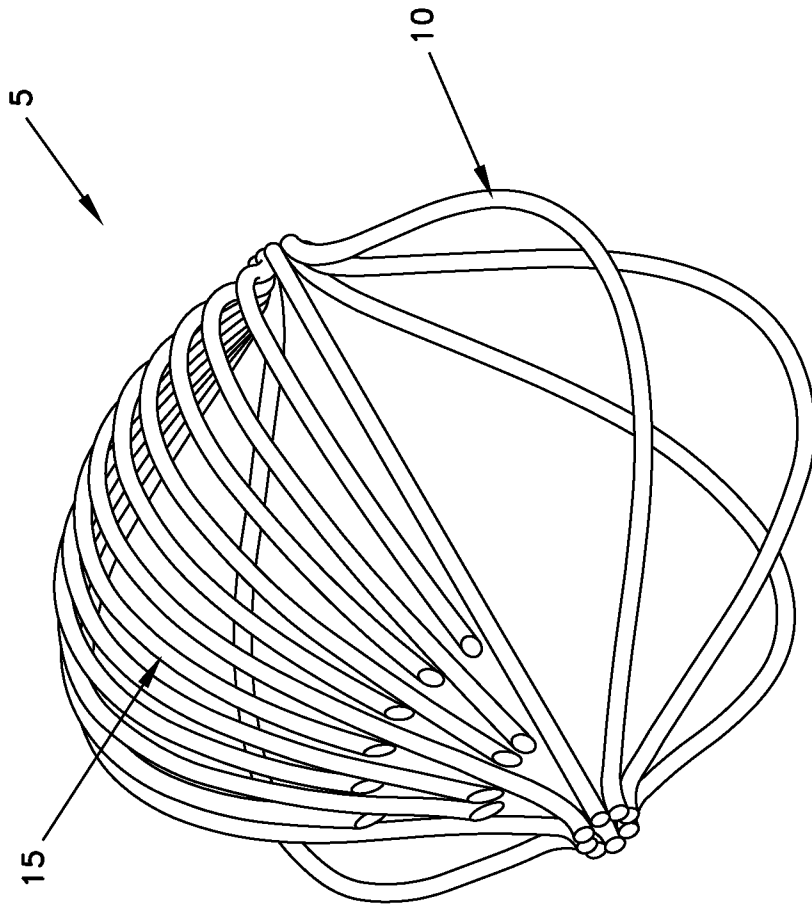

FIG. 58

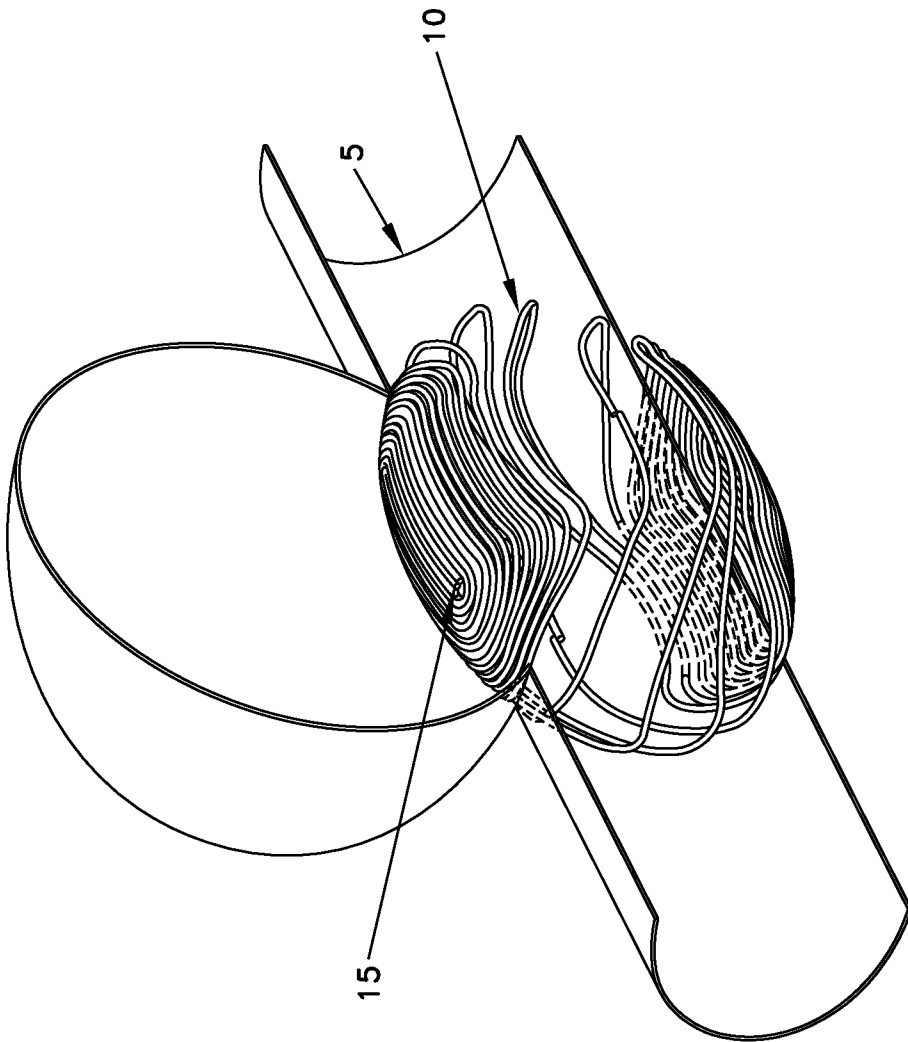

FIG. 59

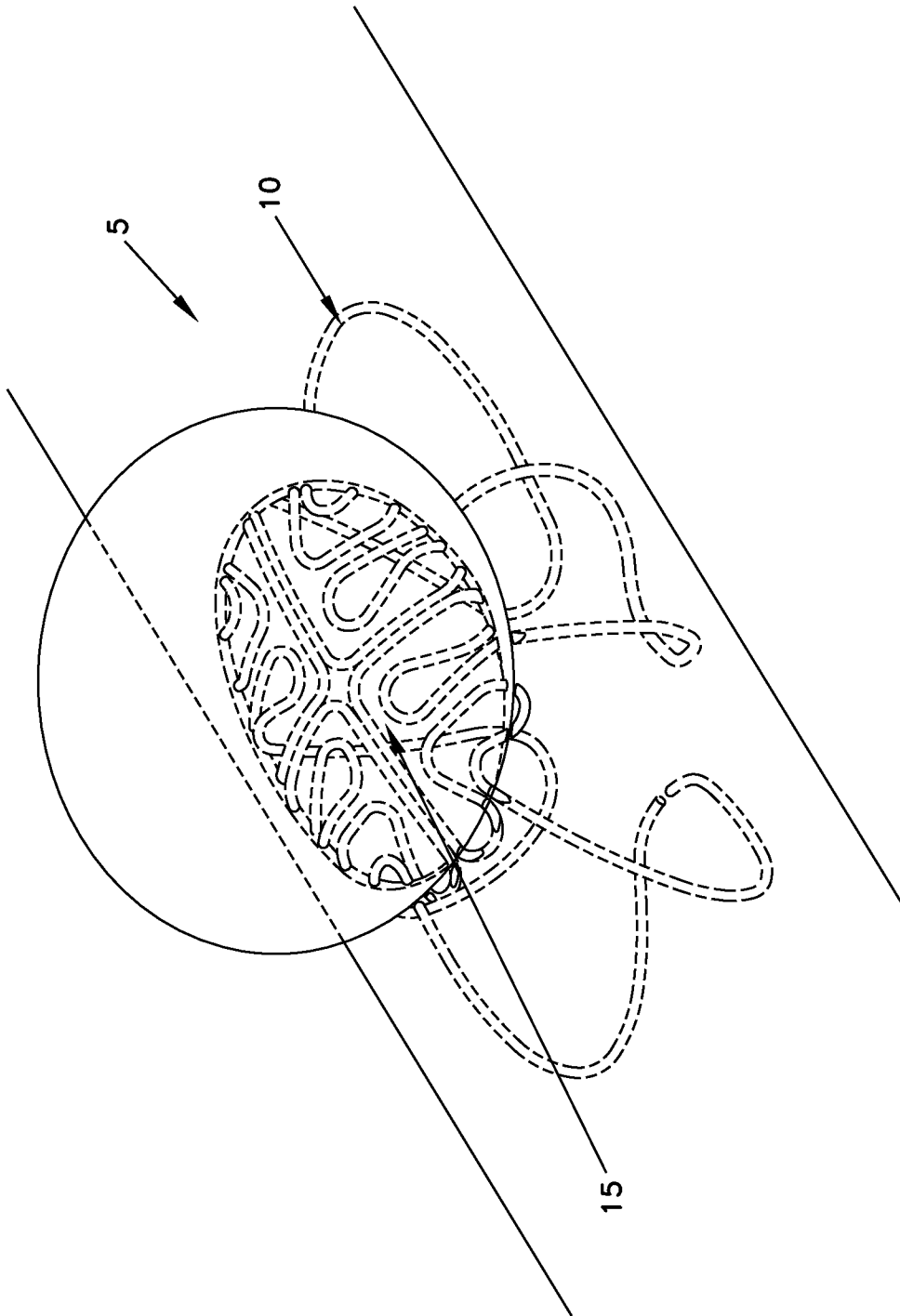

FIG. 60

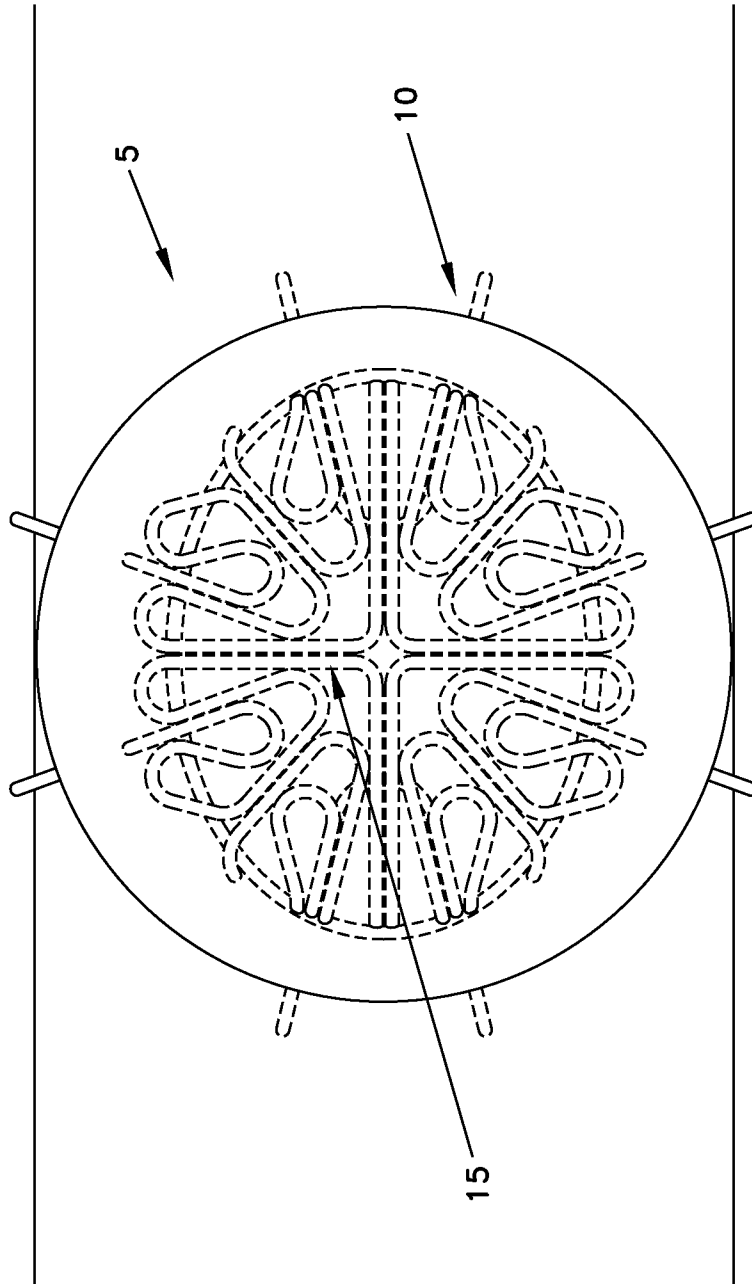

FIG. 61

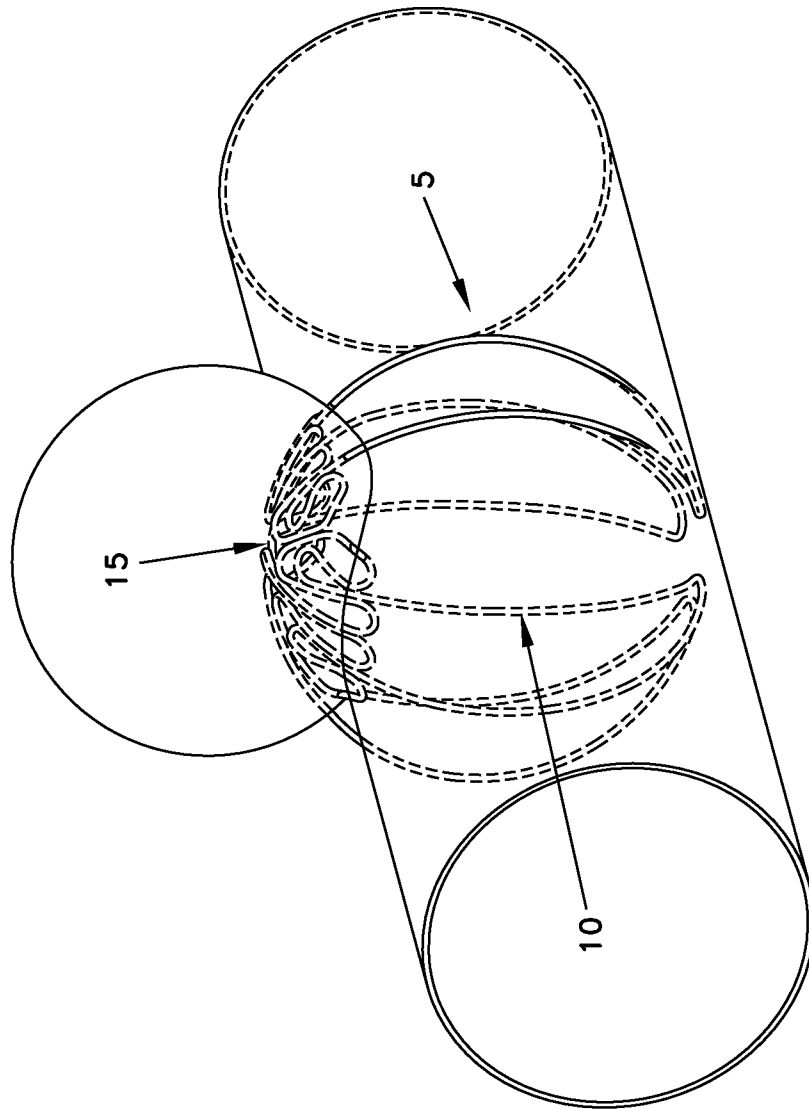

FIG. 62

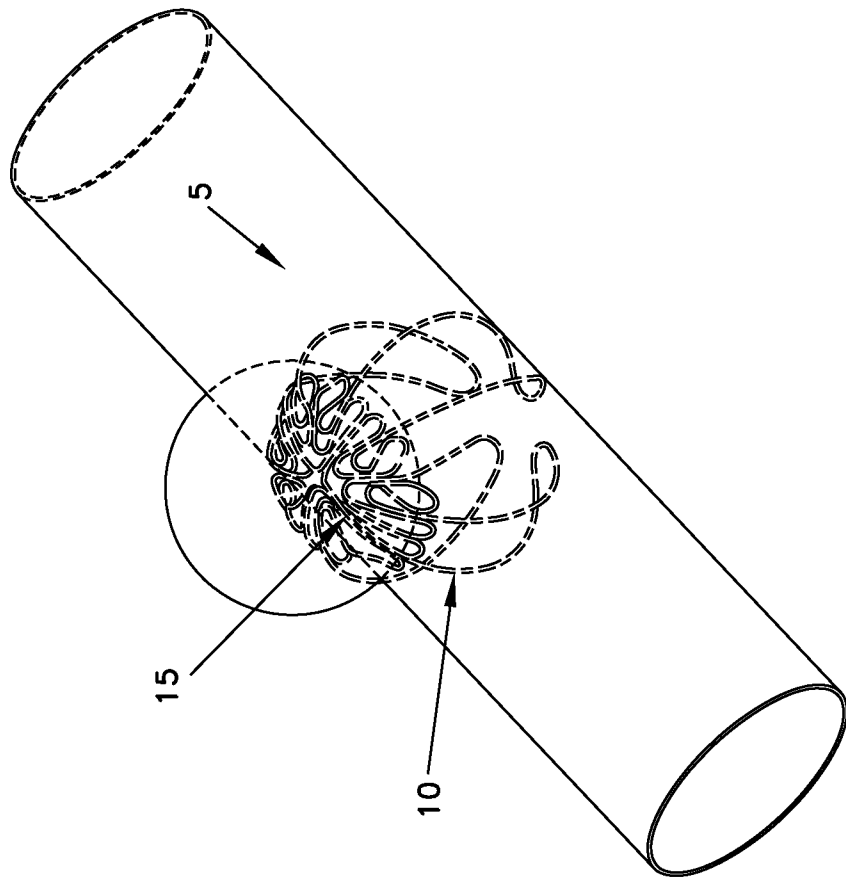

FIG. 63

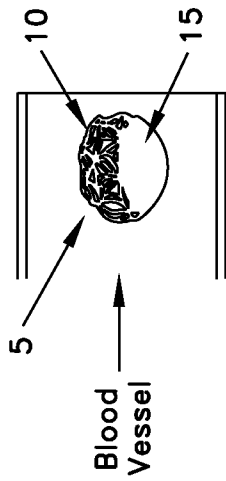

FIG. 64

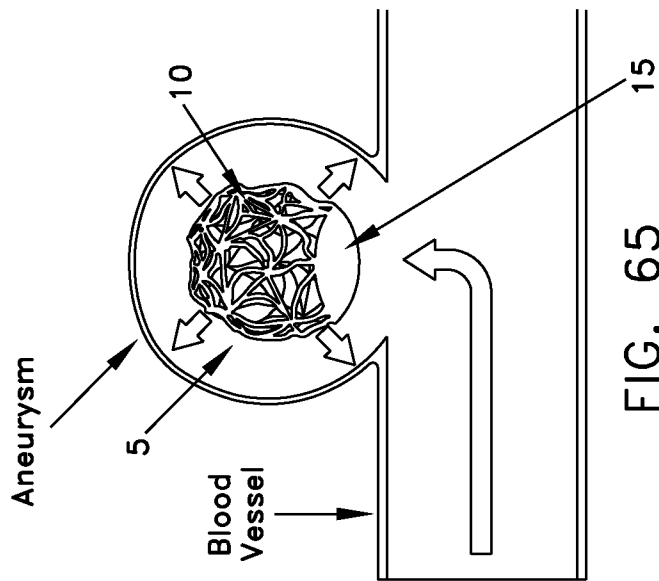

FIG. 65

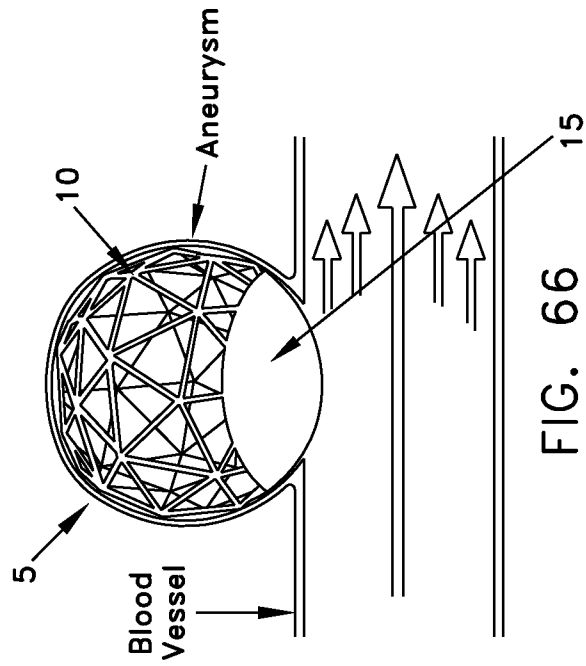

FIG. 66

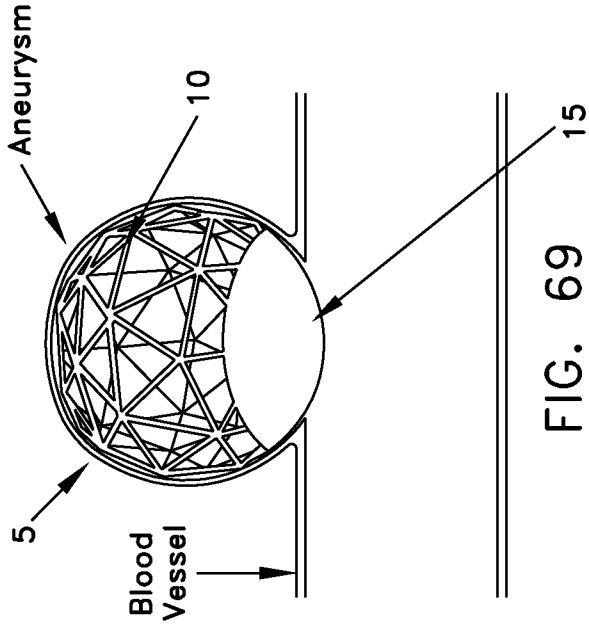

FIG. 67

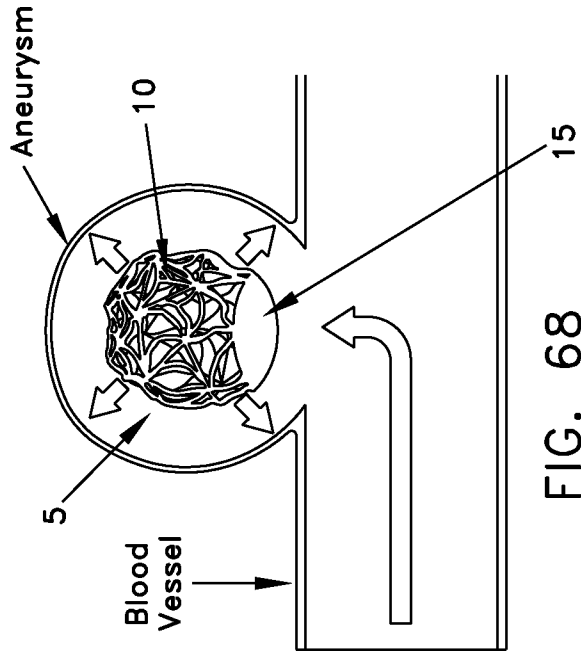

FIG. 68

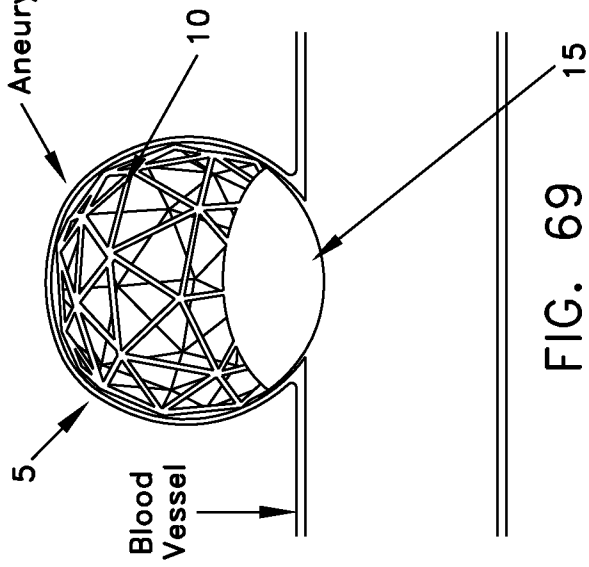

FIG. 69

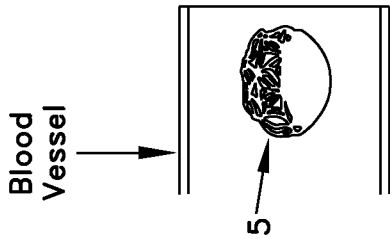

FIG. 70

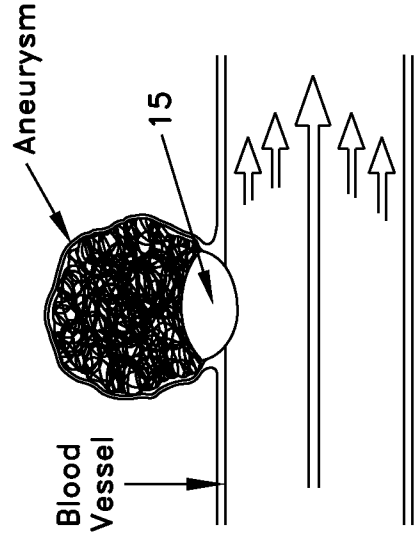

FIG. 71

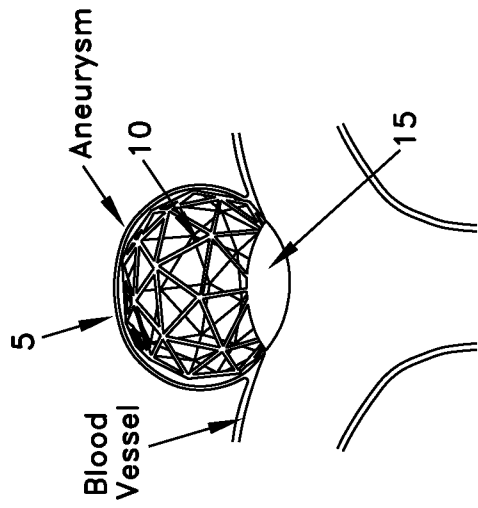

FIG. 72

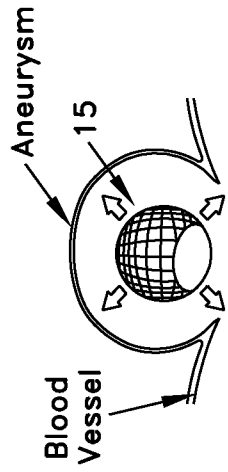

FIG. 73

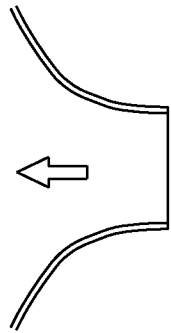

FIG. 74

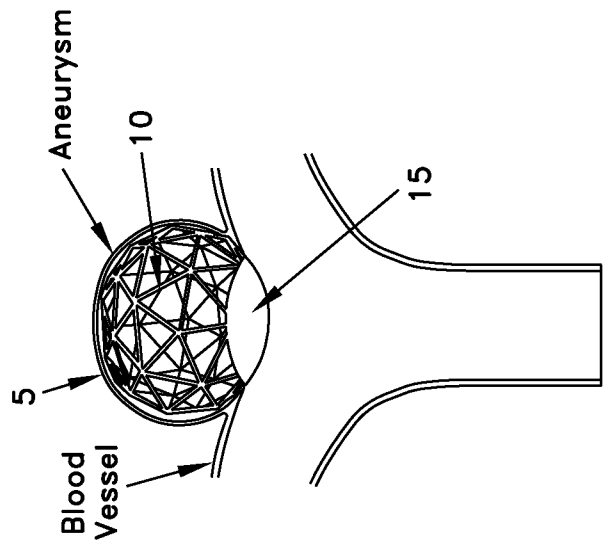

FIG. 75

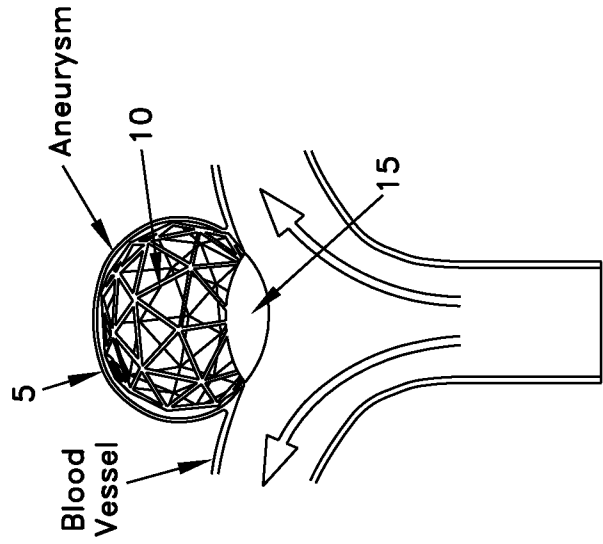

FIG. 76

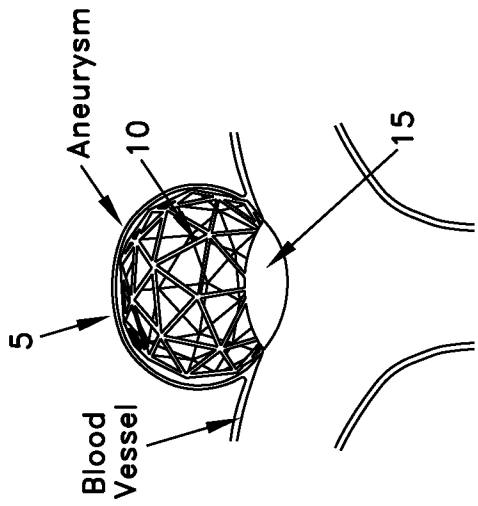

FIG. 77

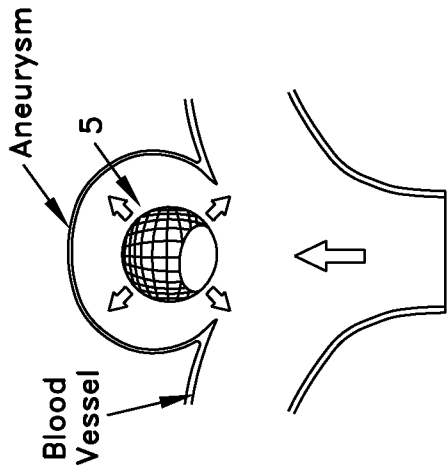

FIG. 78



FIG. 79

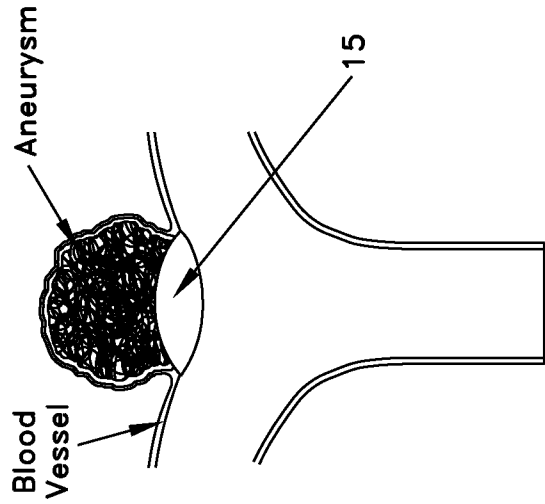

FIG. 80

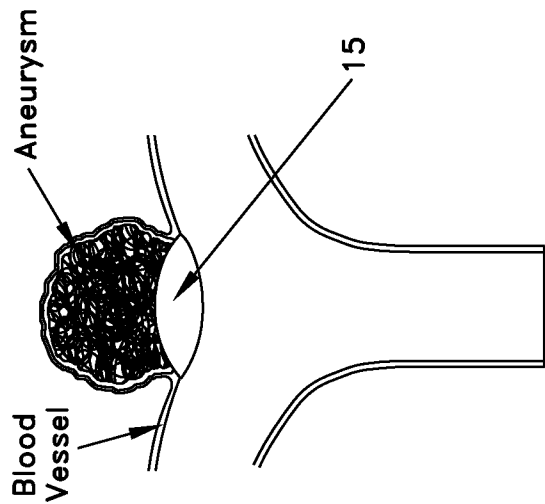

FIG. 81

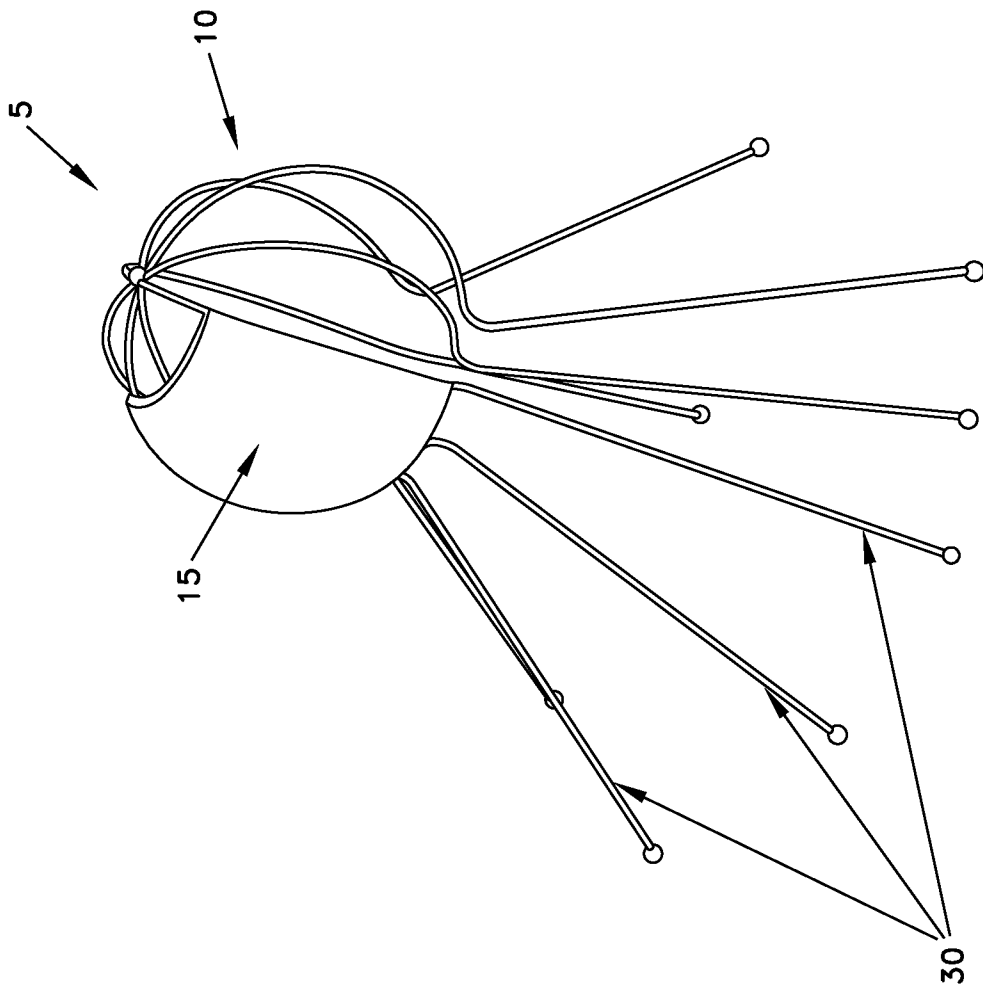

FIG. 82

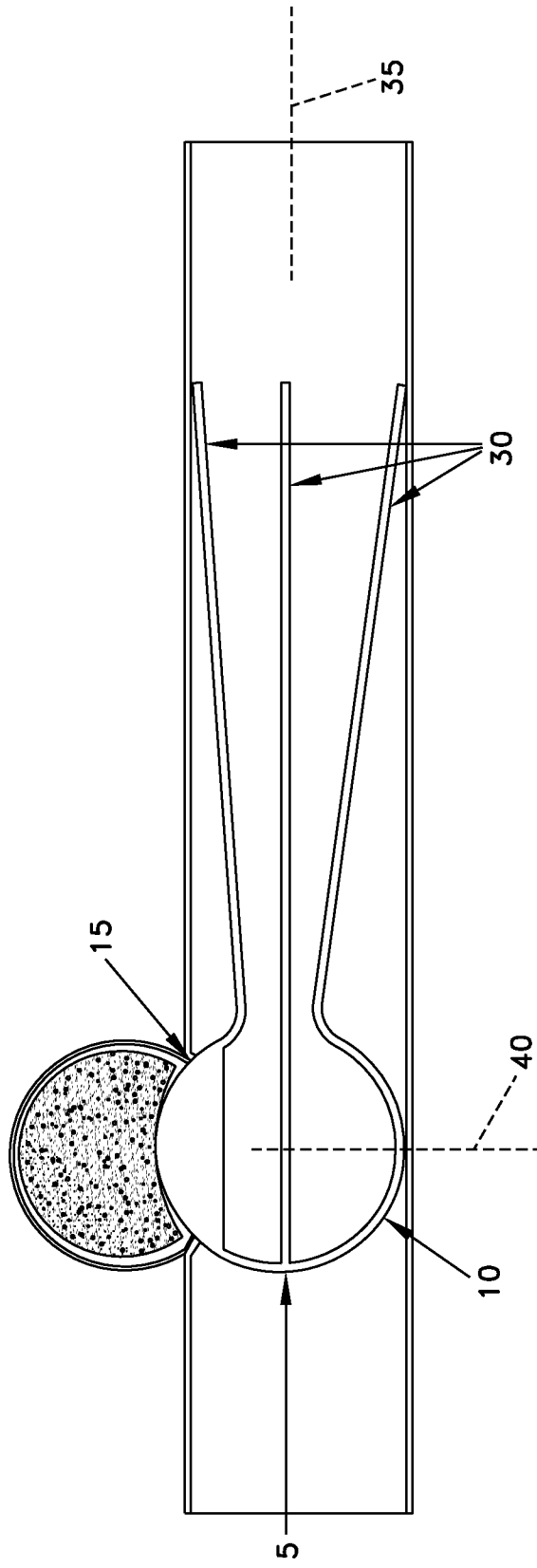

FIG. 83

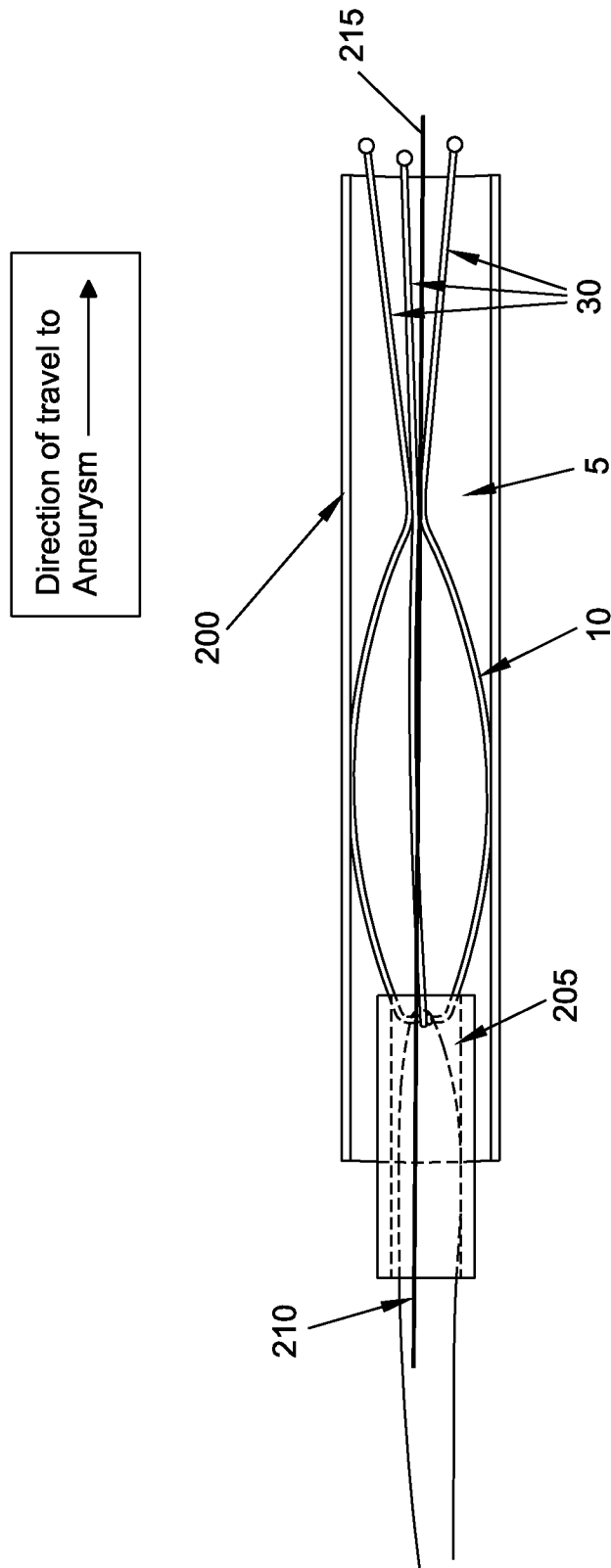

FIG. 84

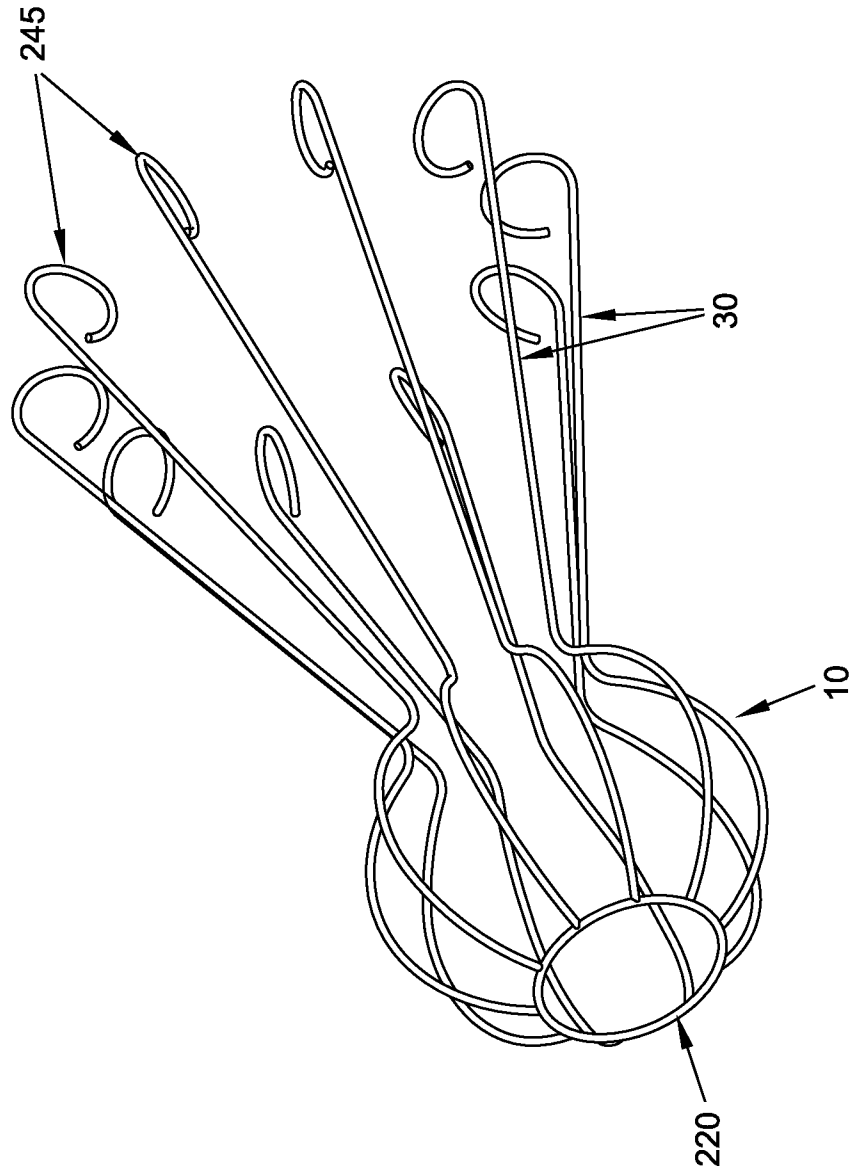

FIG. 85

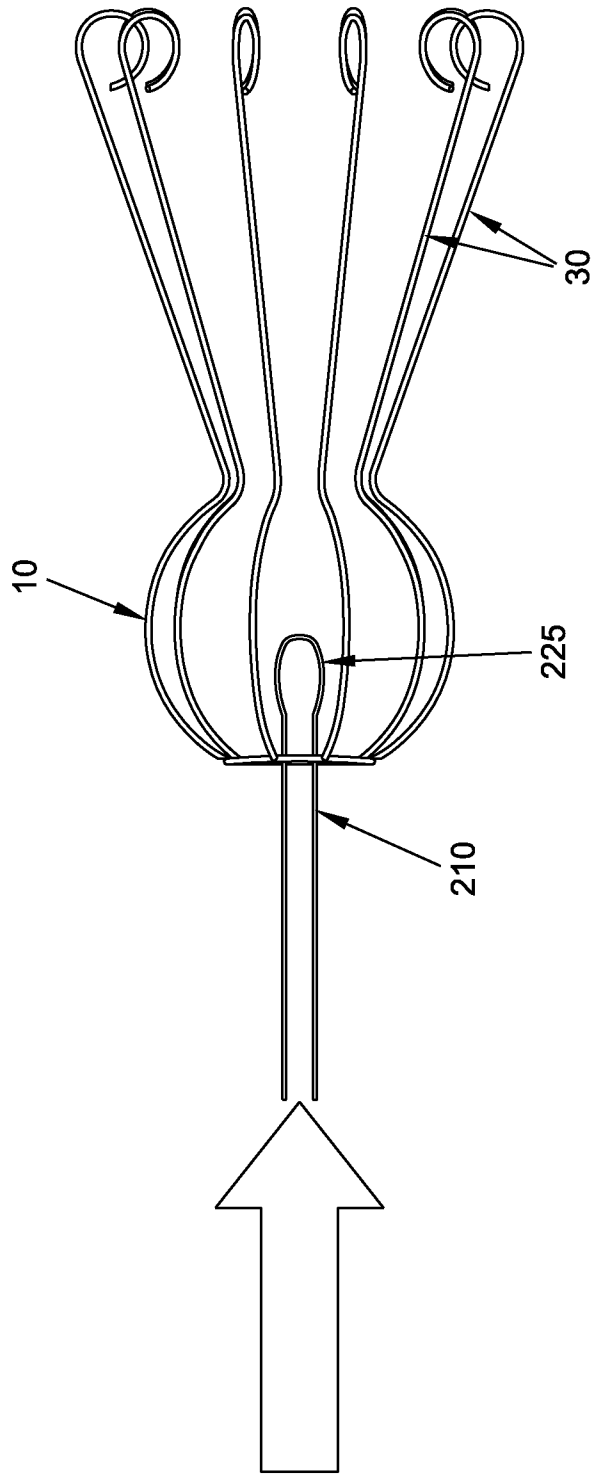

FIG. 86

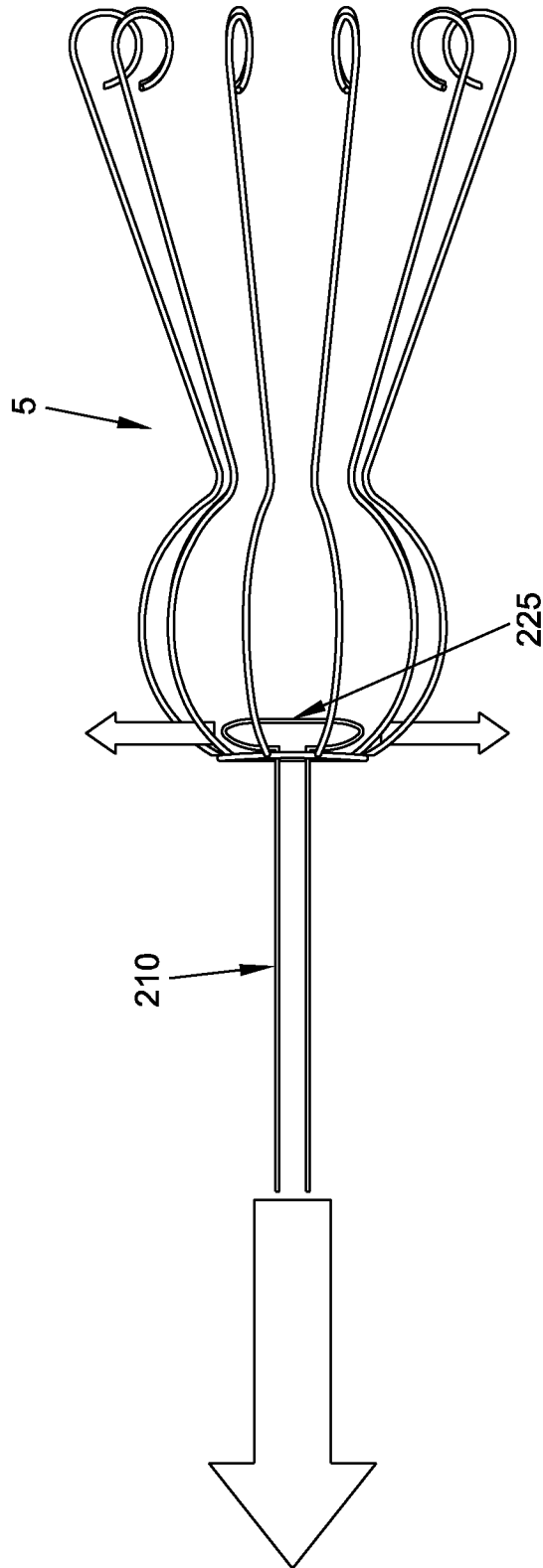

FIG. 87

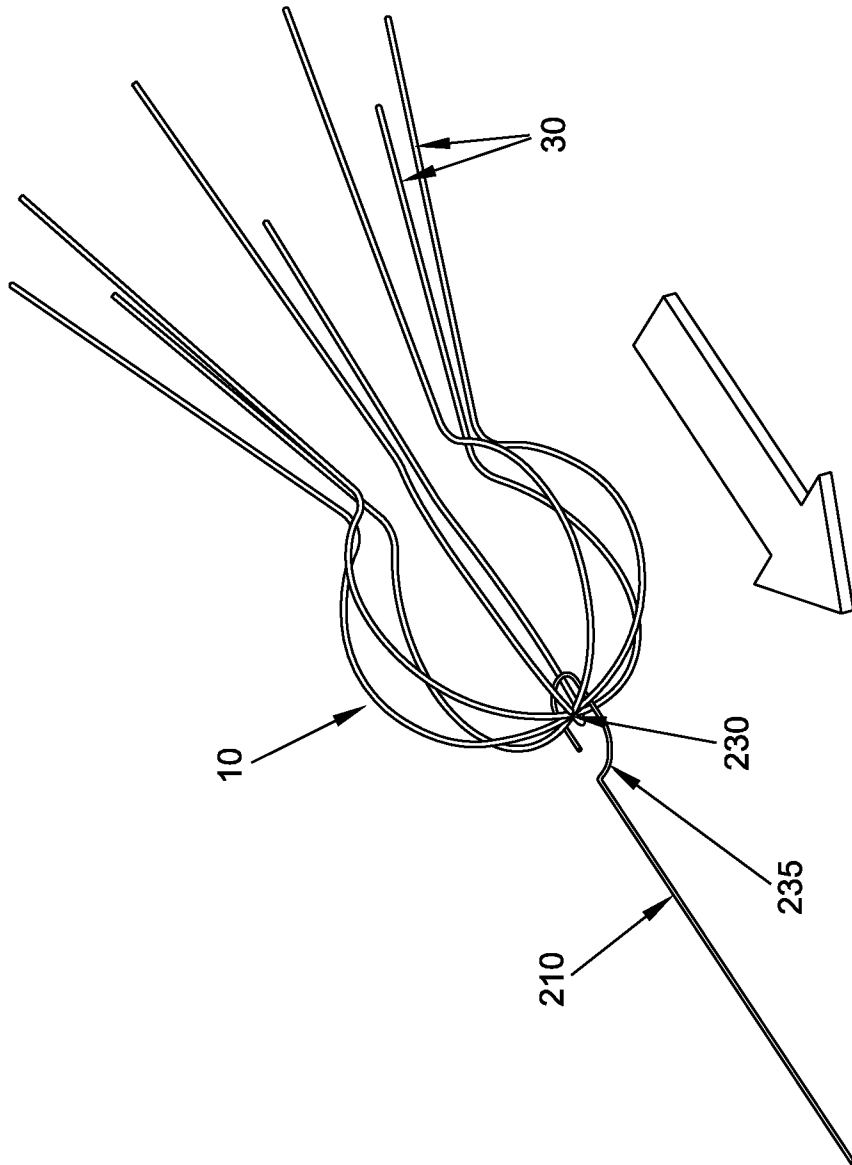

FIG. 88

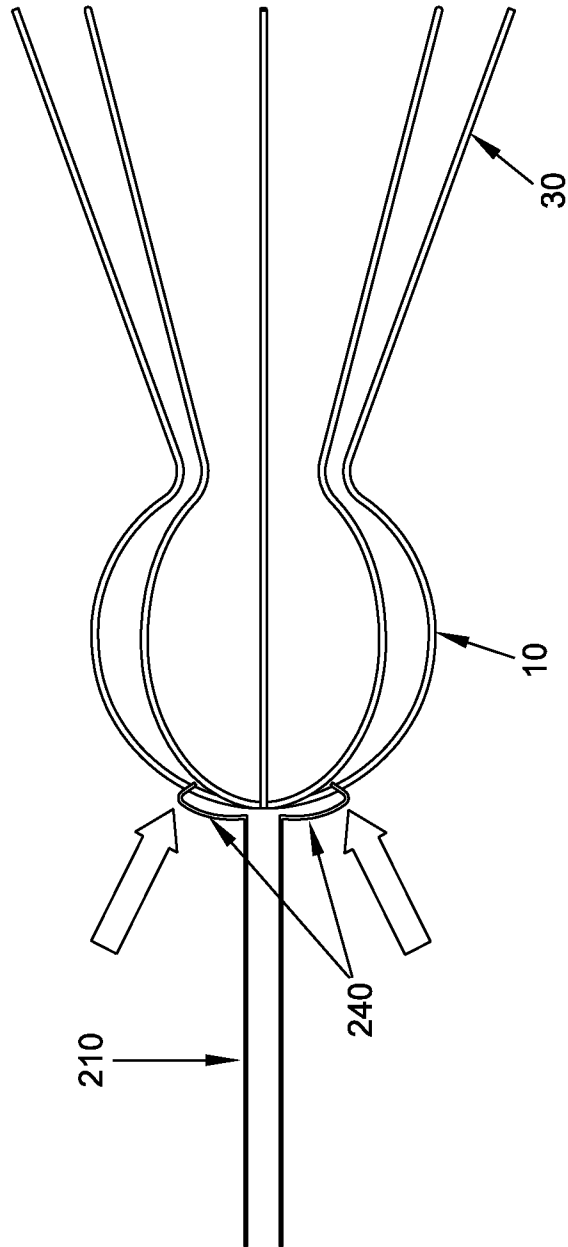

FIG. 89

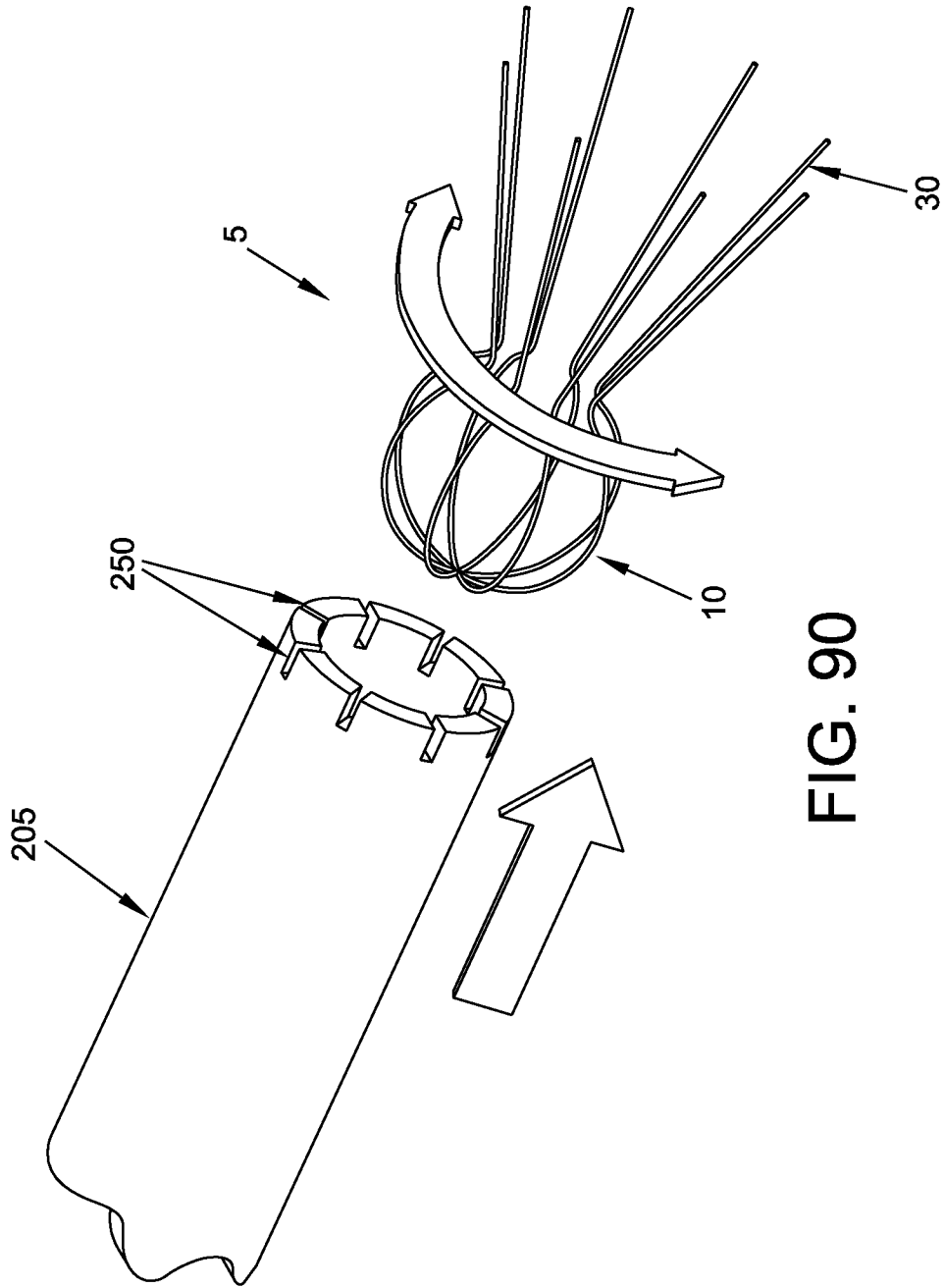

FIG. 90

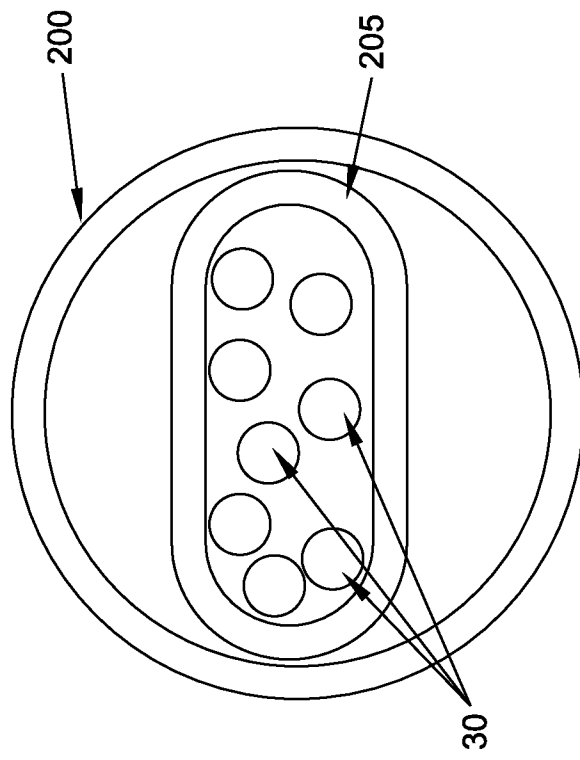

FIG. 91

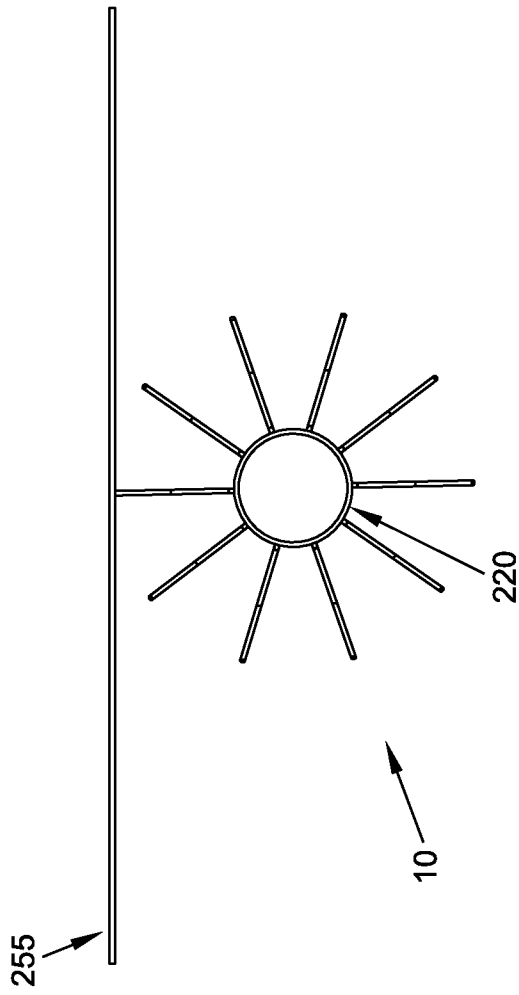

FIG. 92

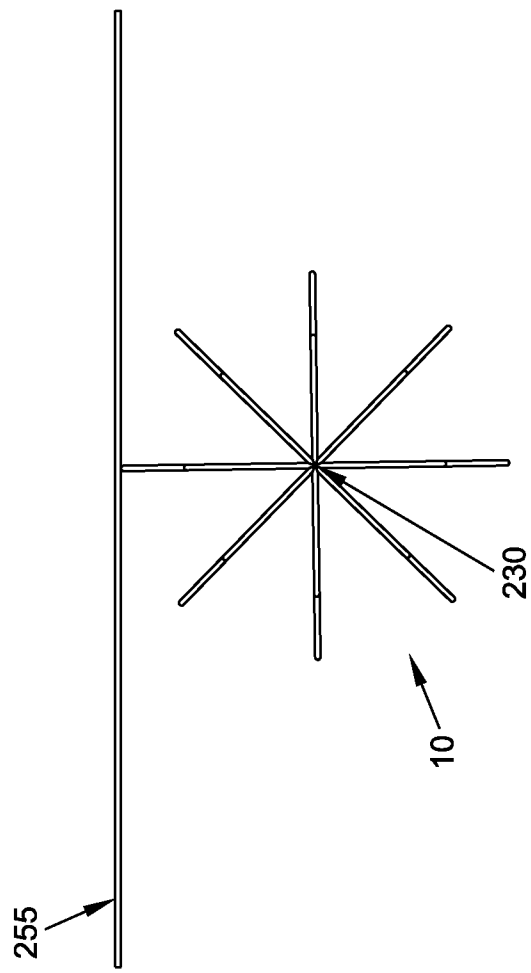

FIG. 93

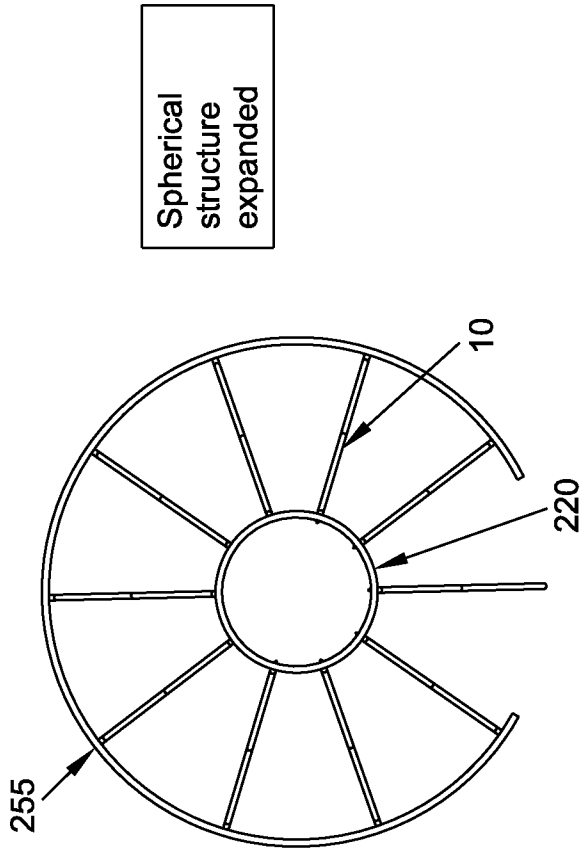

FIG. 94

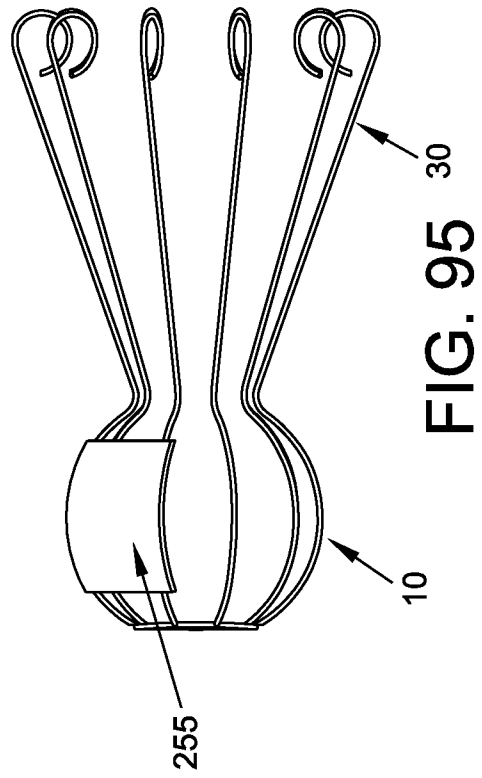

FIG. 95

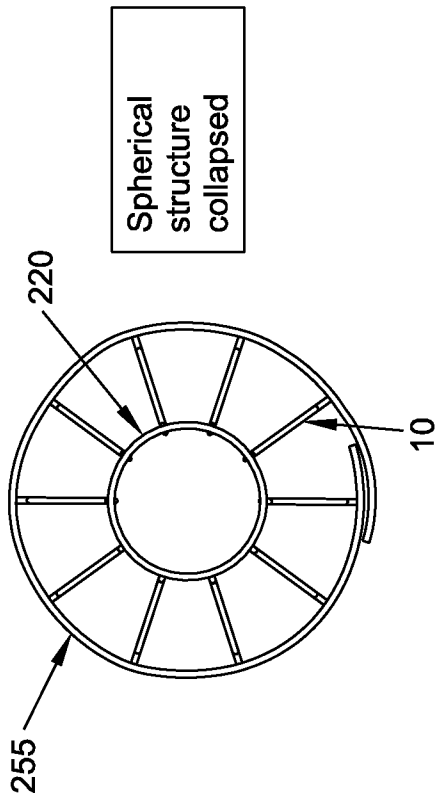

FIG. 96

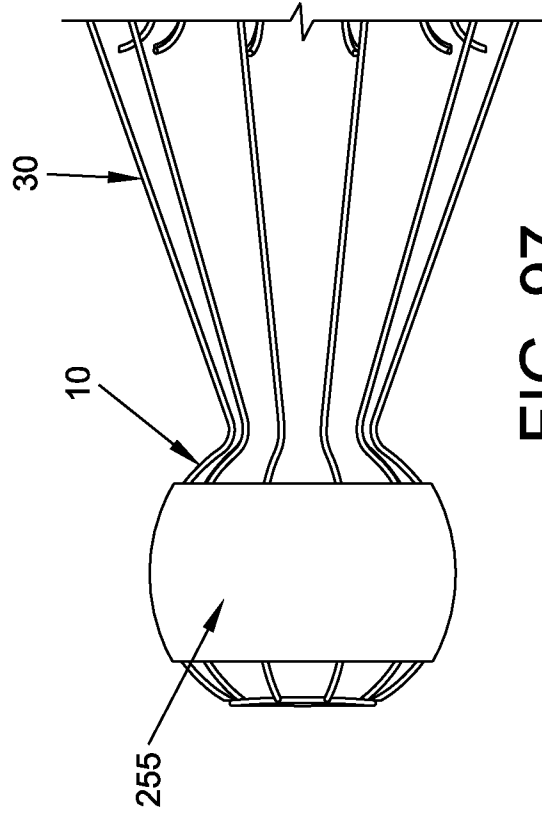

FIG. 97

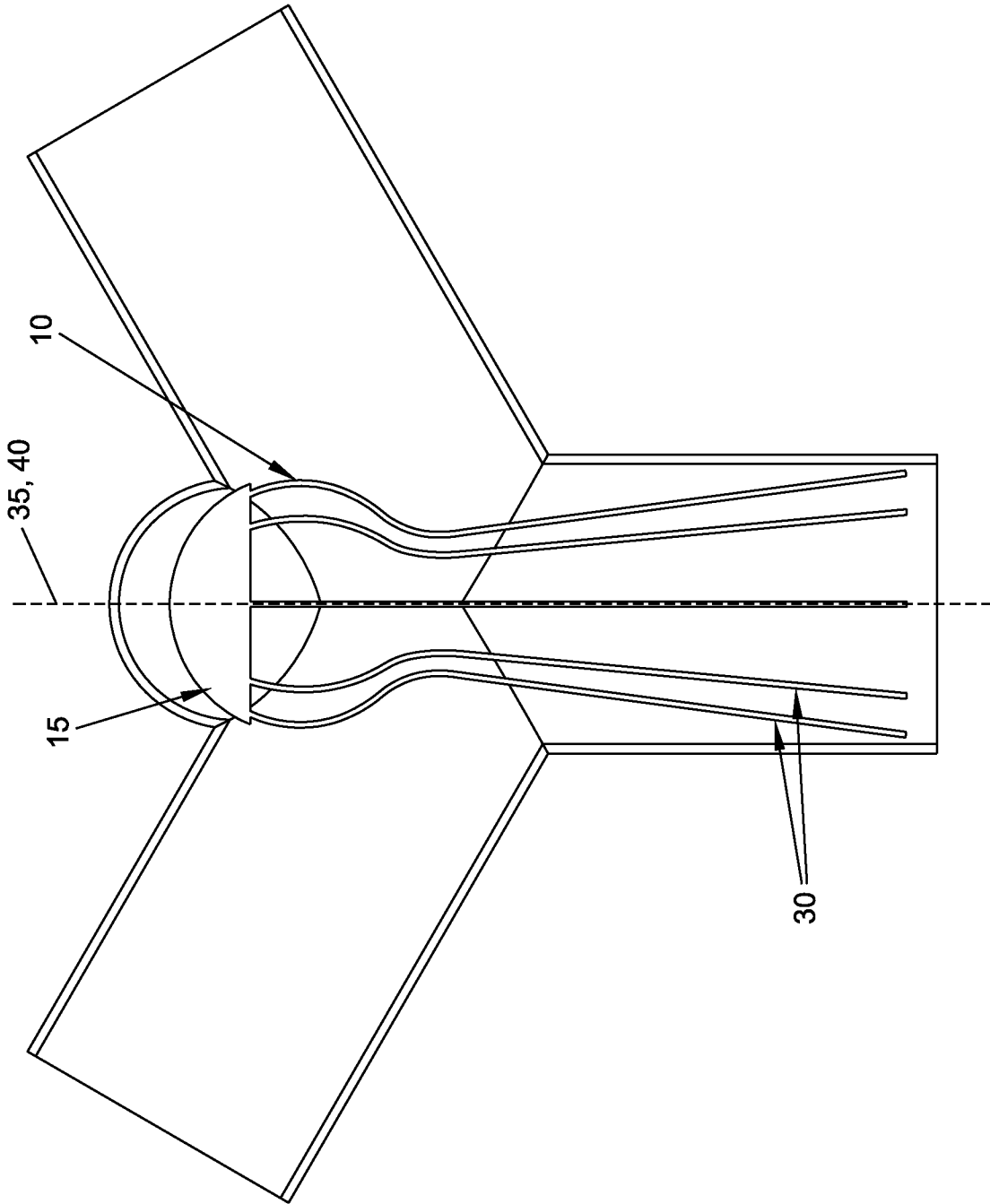

FIG. 98

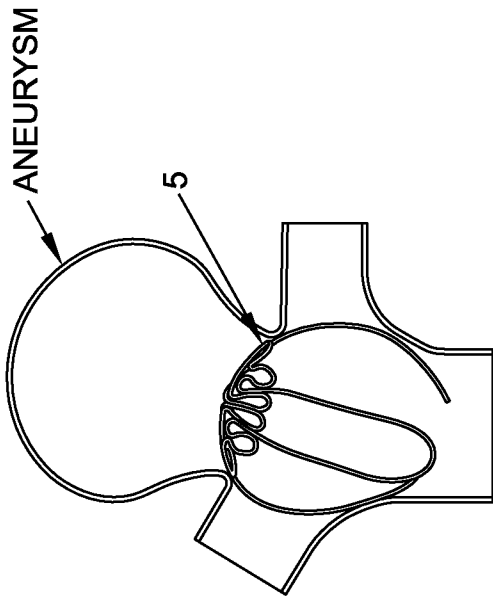

FIG. 99

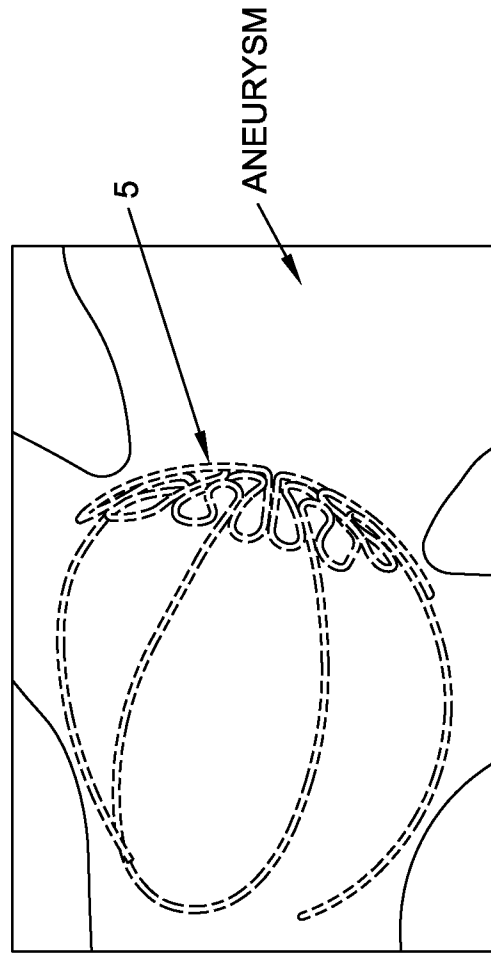
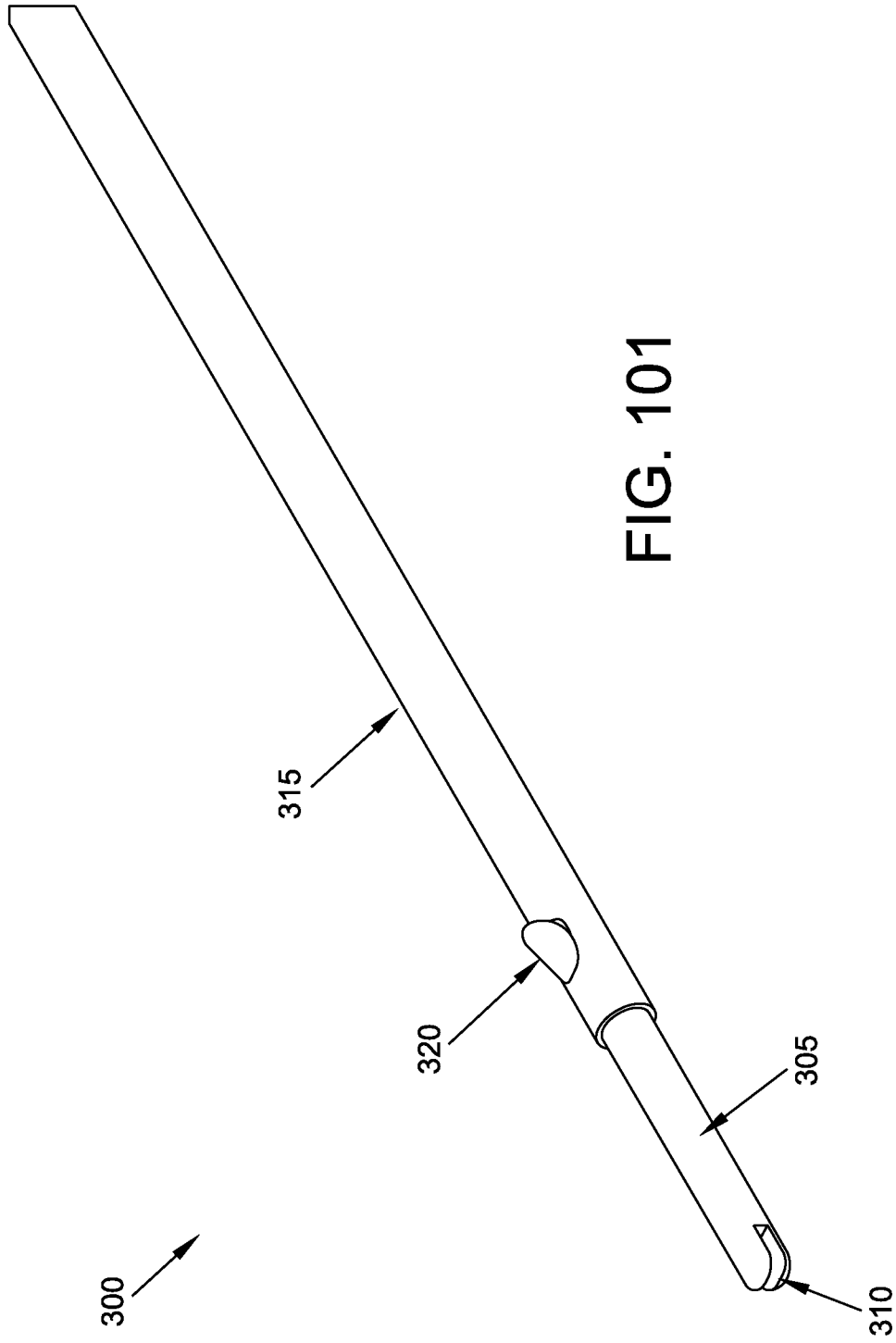

FIG. 100



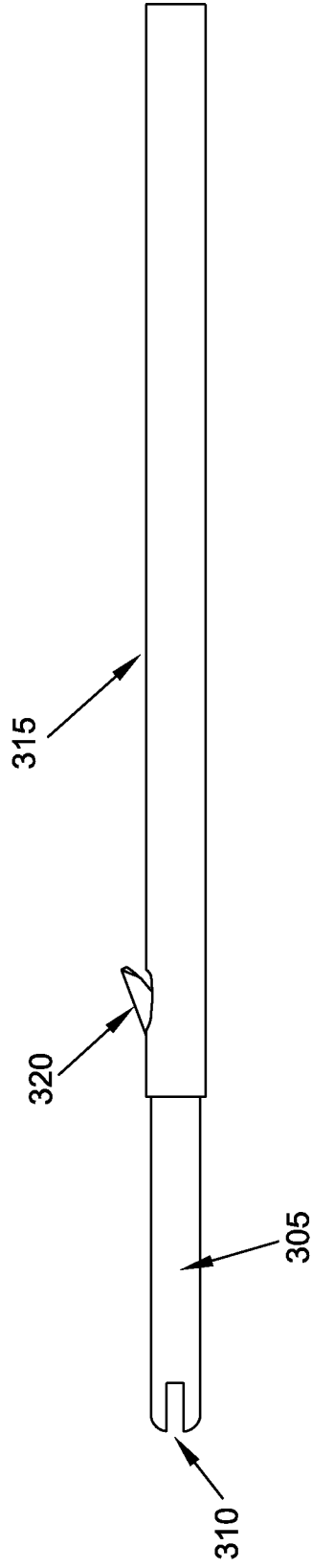
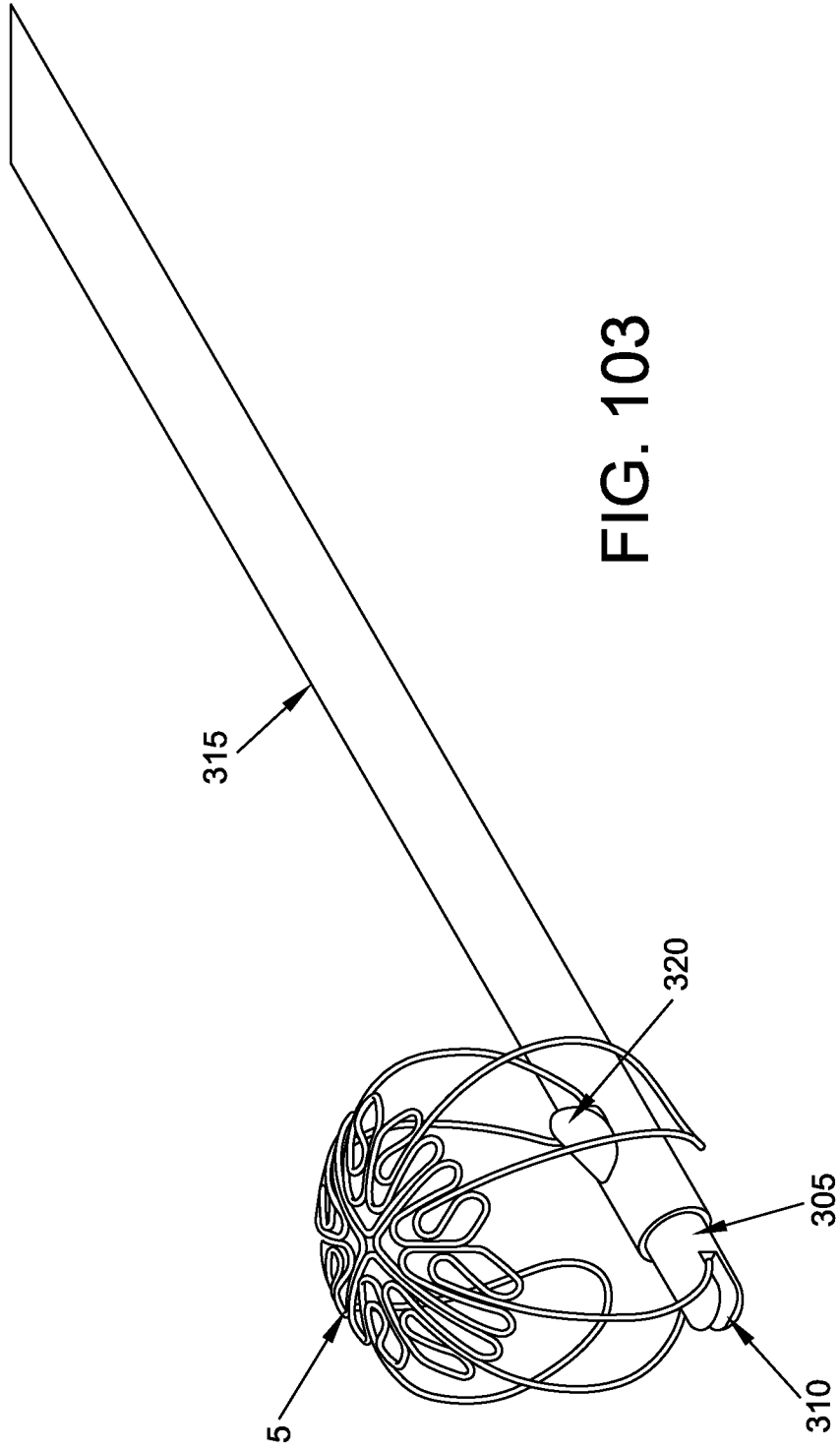
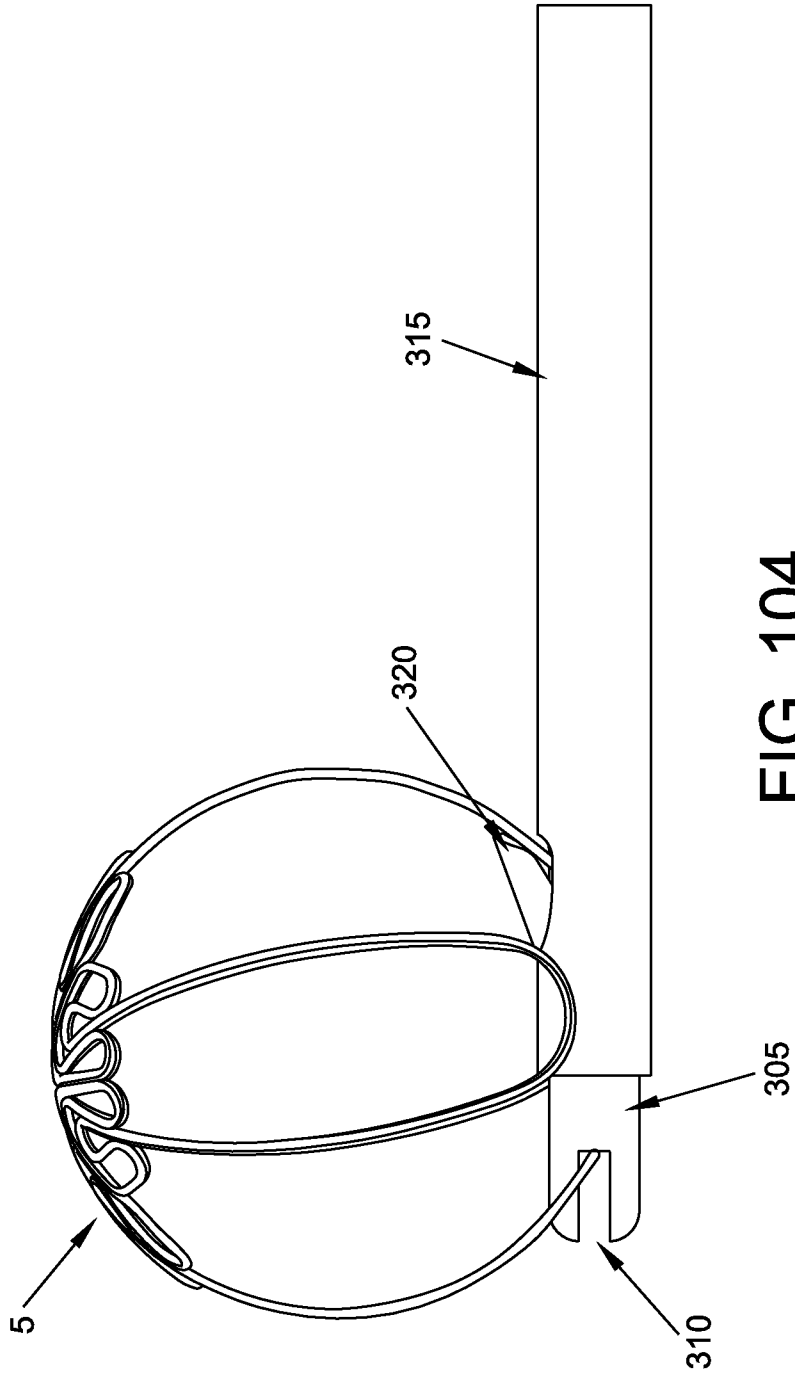

FIG. 102





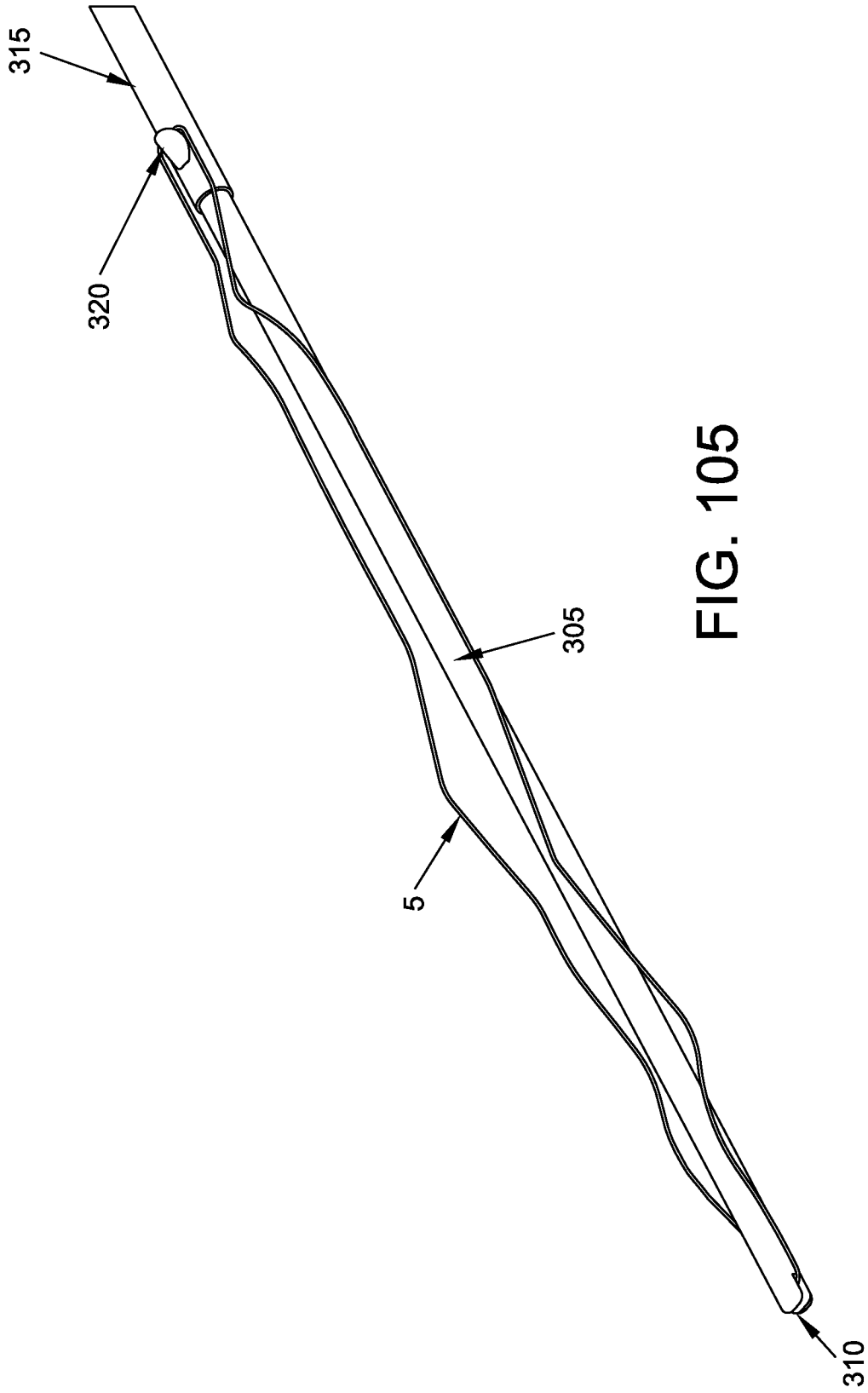

FIG. 105

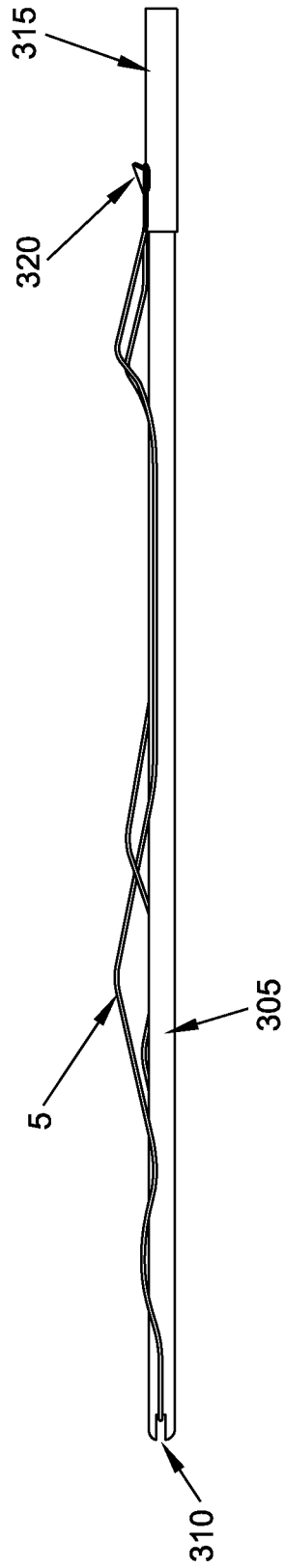

FIG. 106

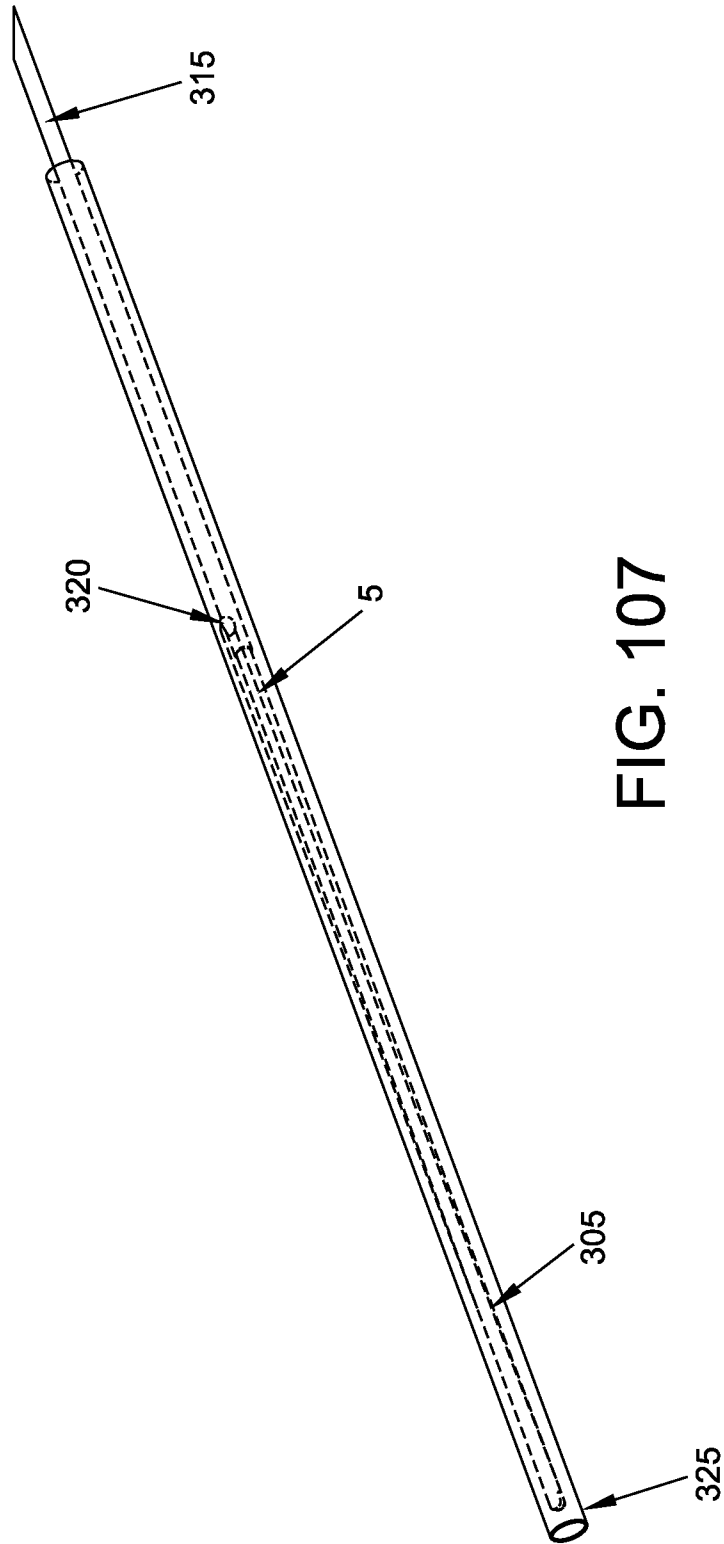

FIG. 107

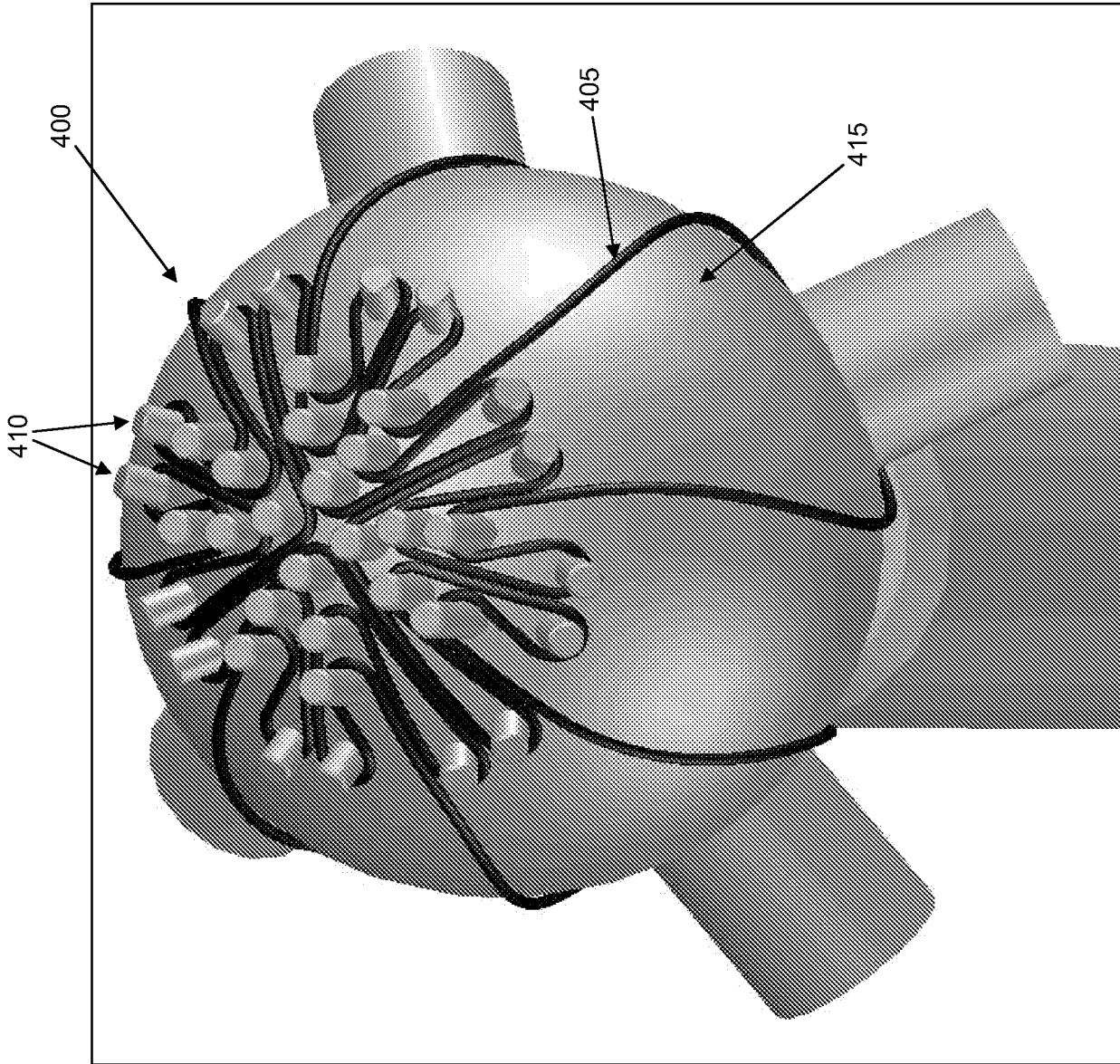

FIG. 108

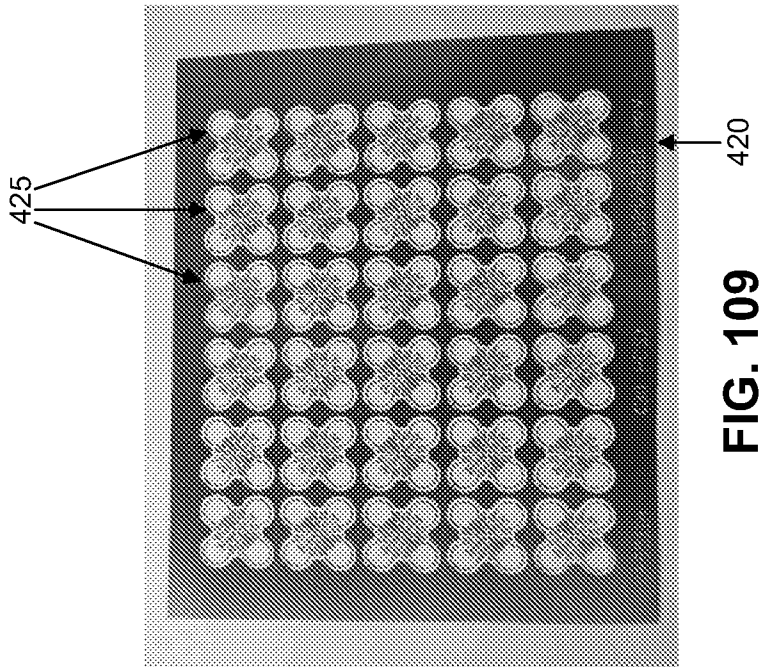

FIG. 109

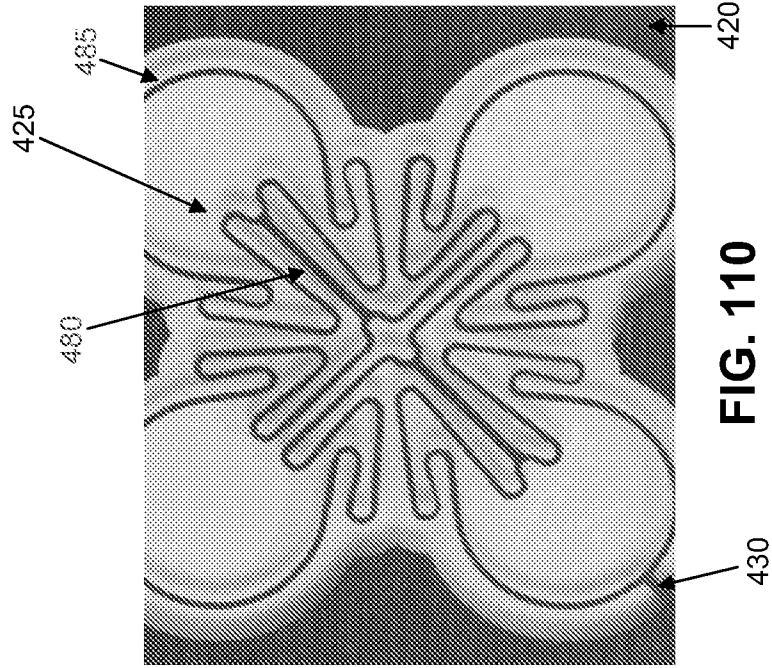

FIG. 110

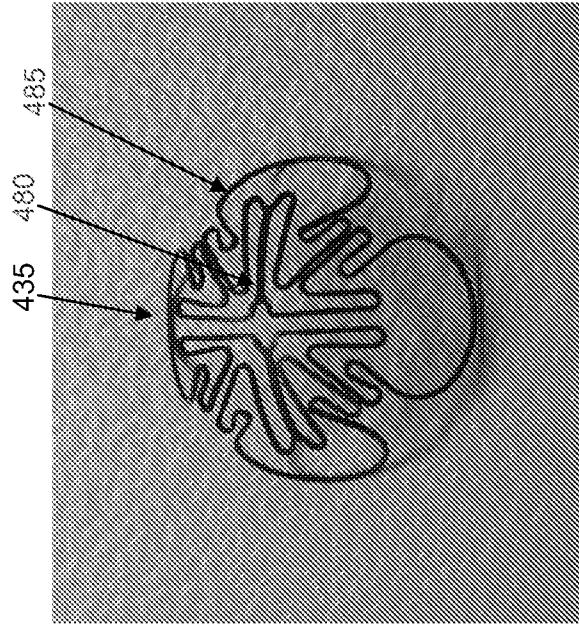

FIG. 111

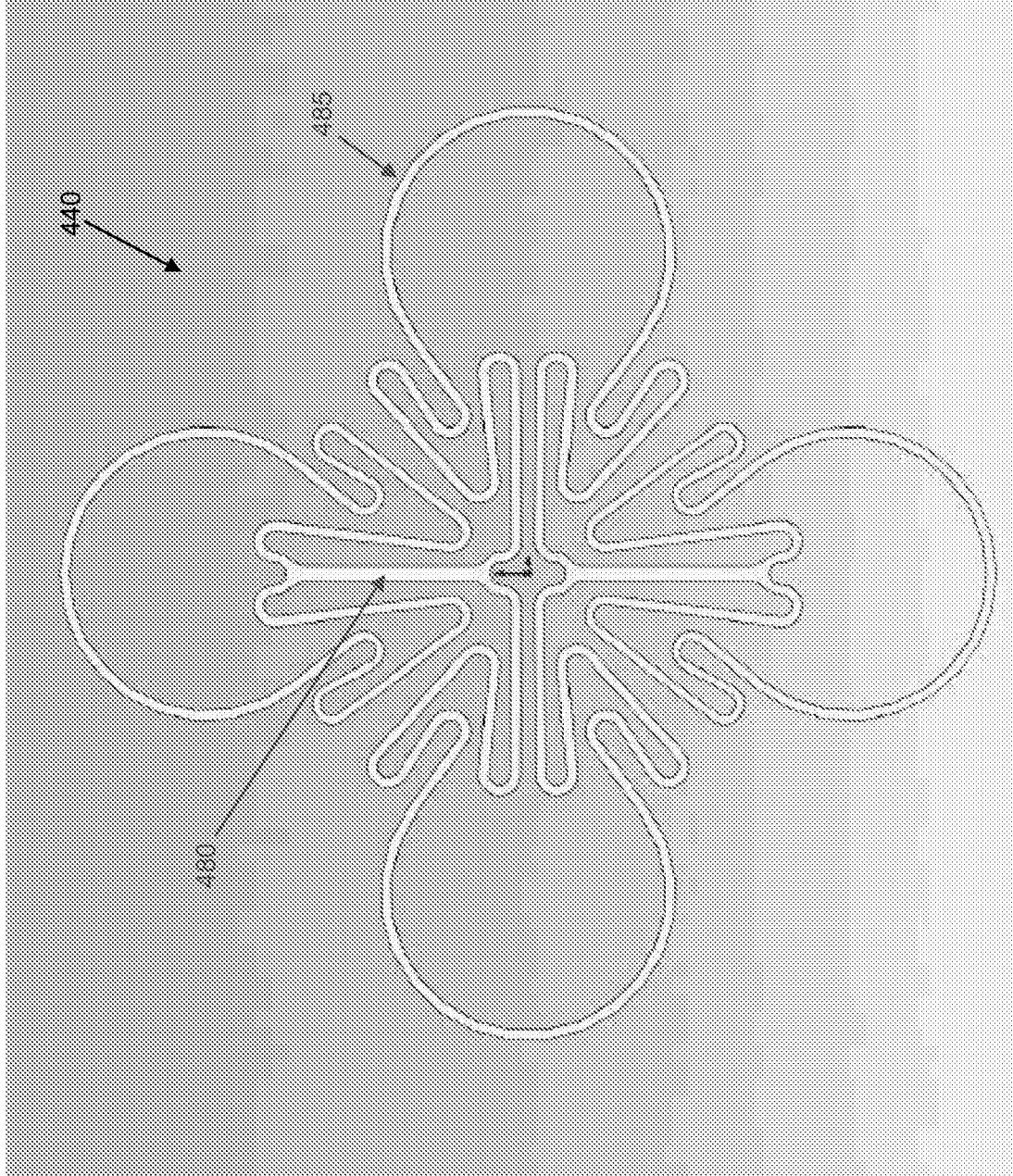

FIG. 112

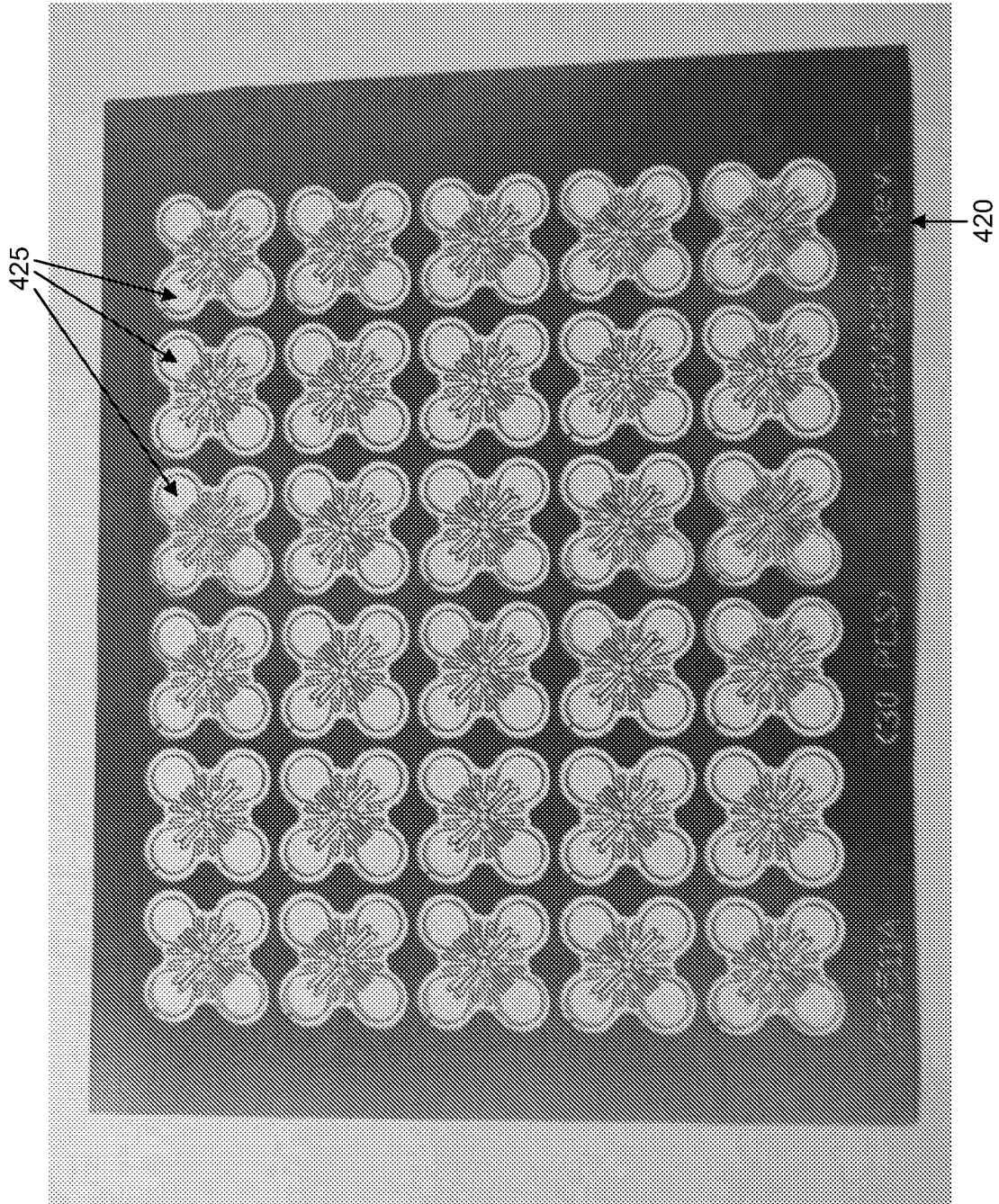

FIG. 113

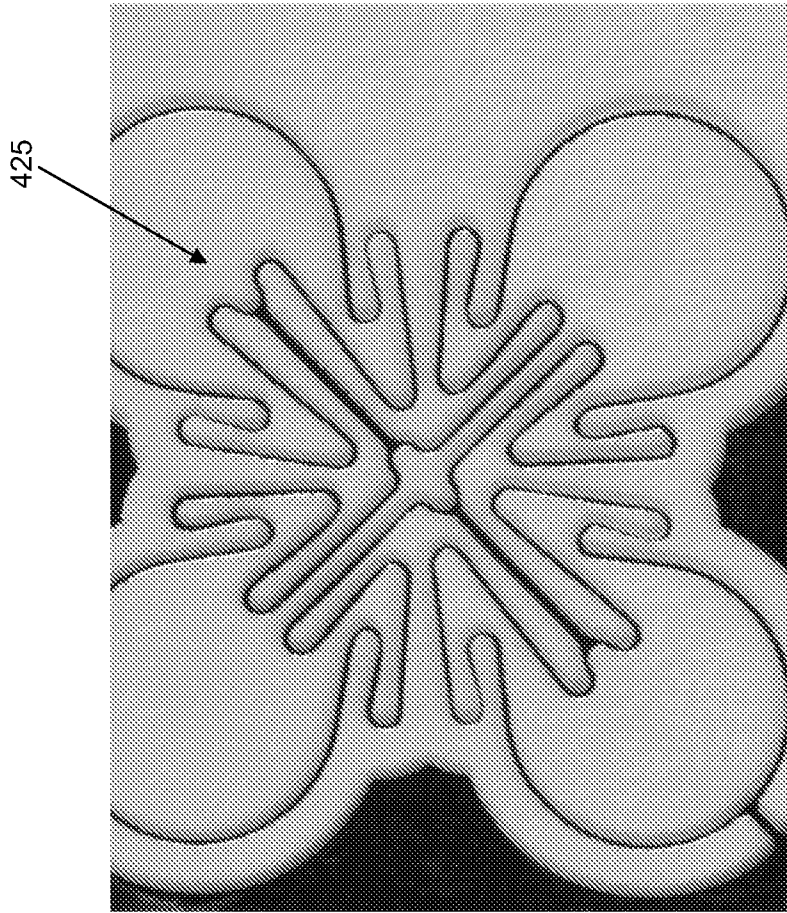

FIG. 115

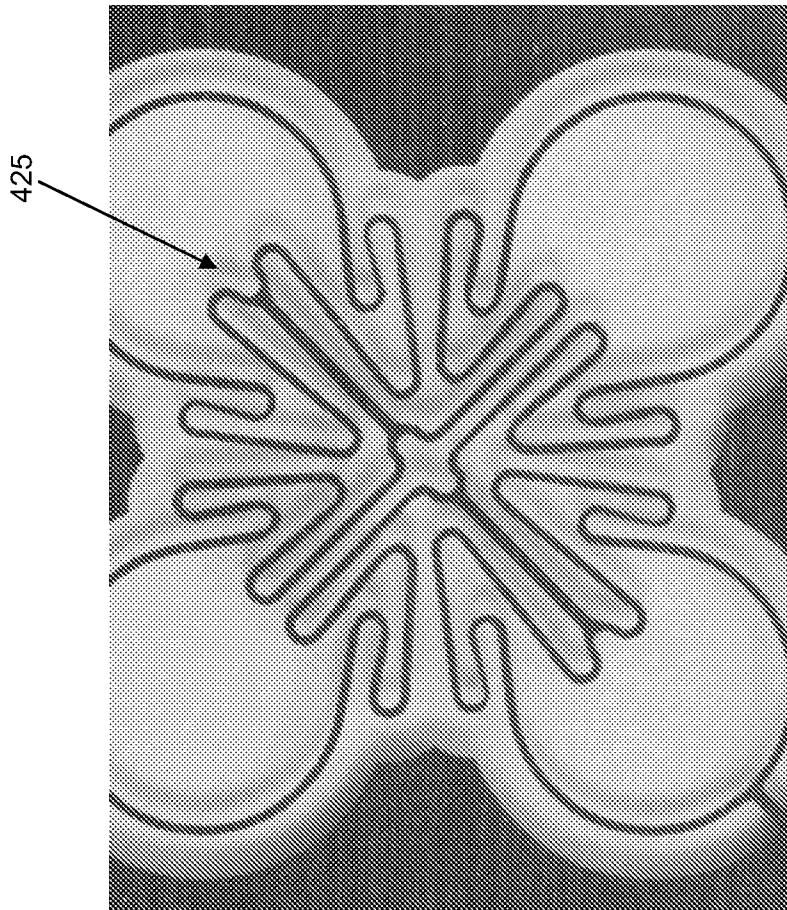

FIG. 114

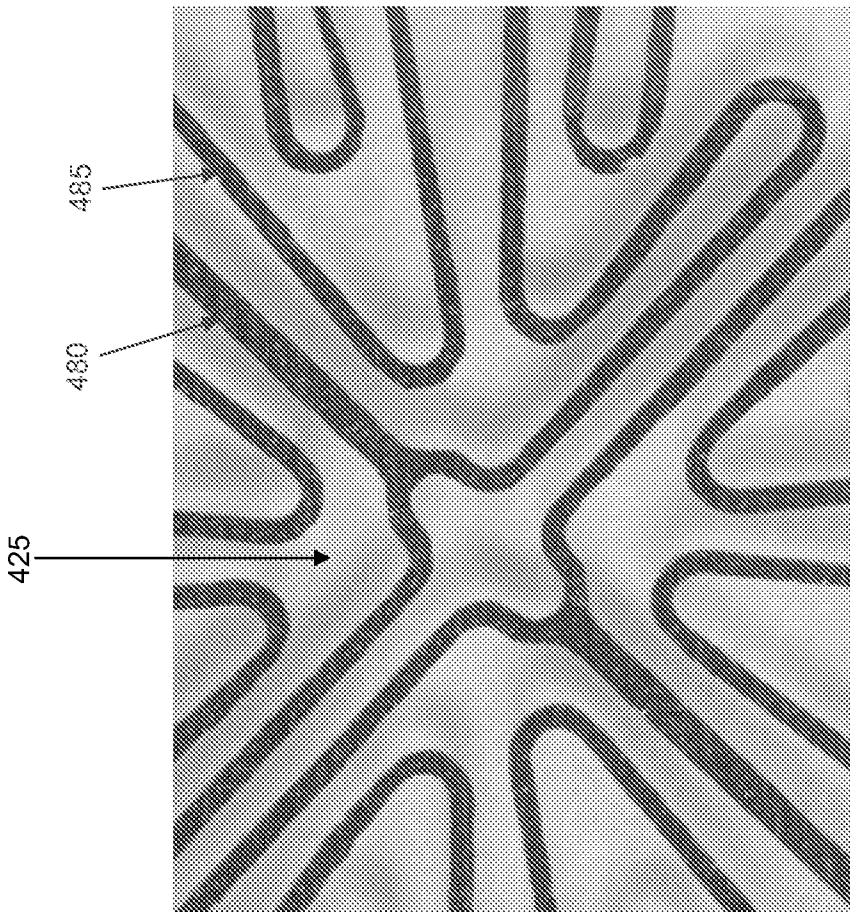

FIG. 116

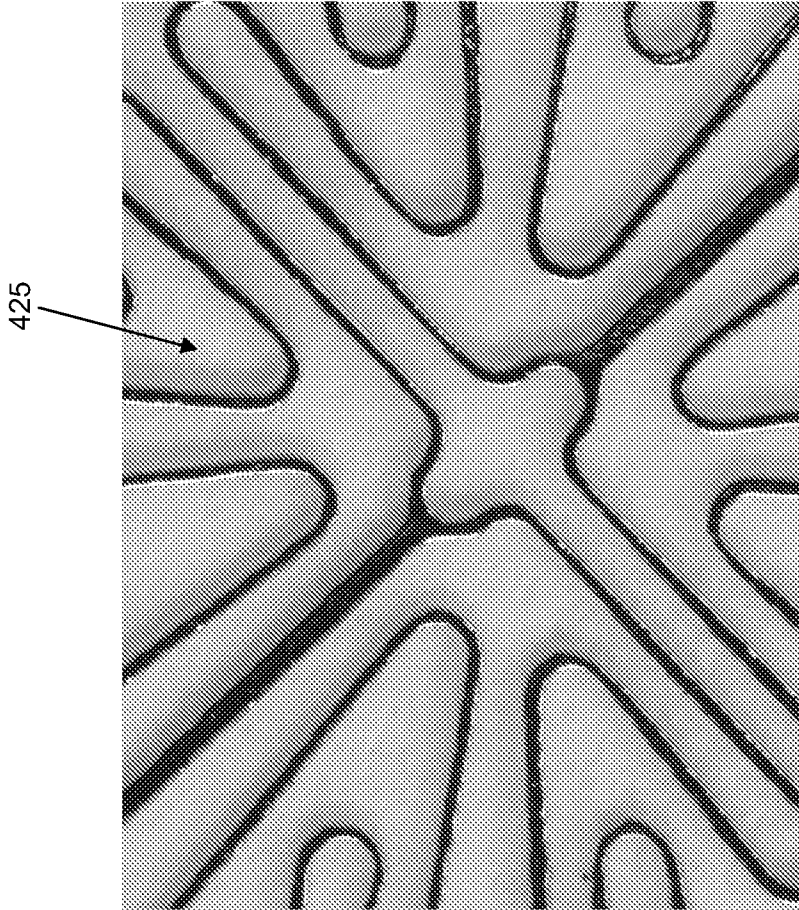

FIG. 117

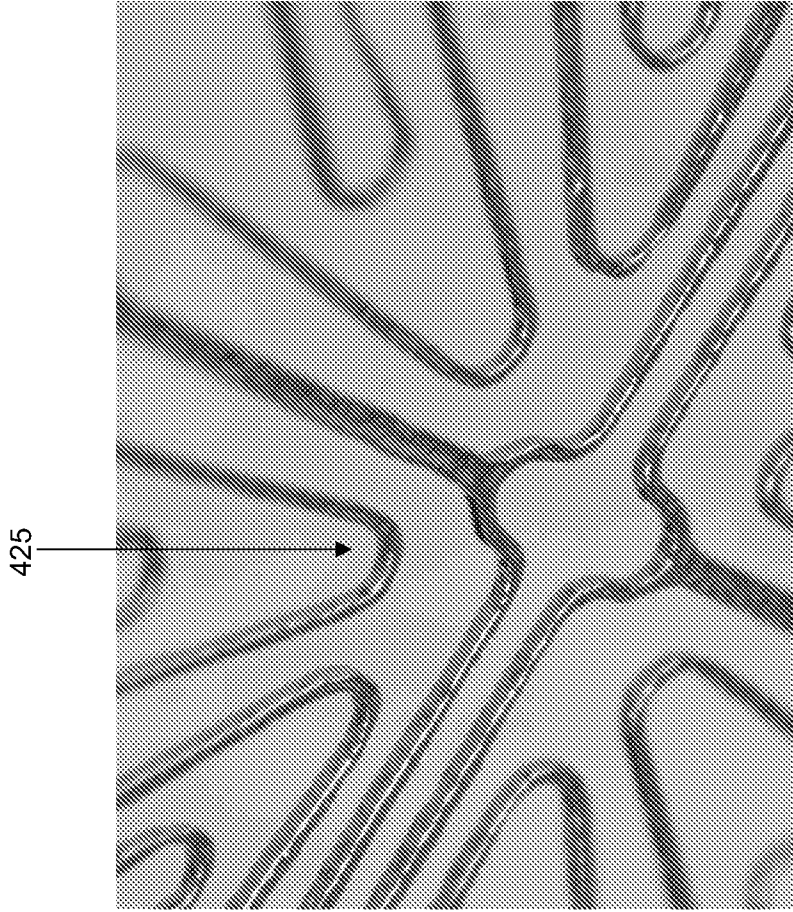

FIG. 119

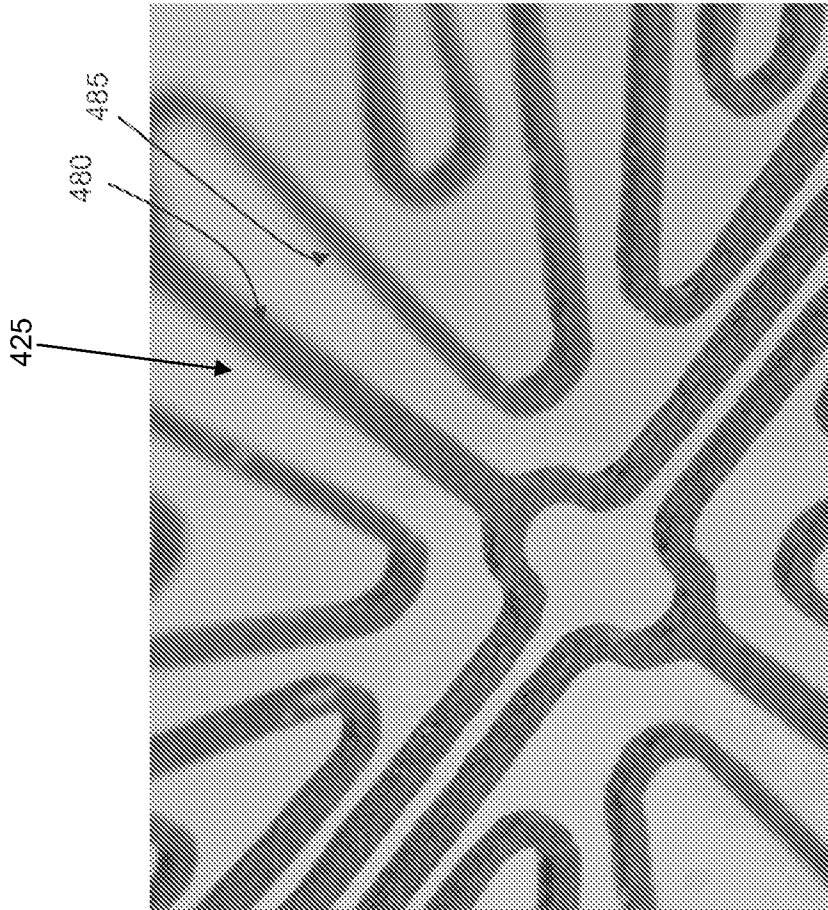

FIG. 118

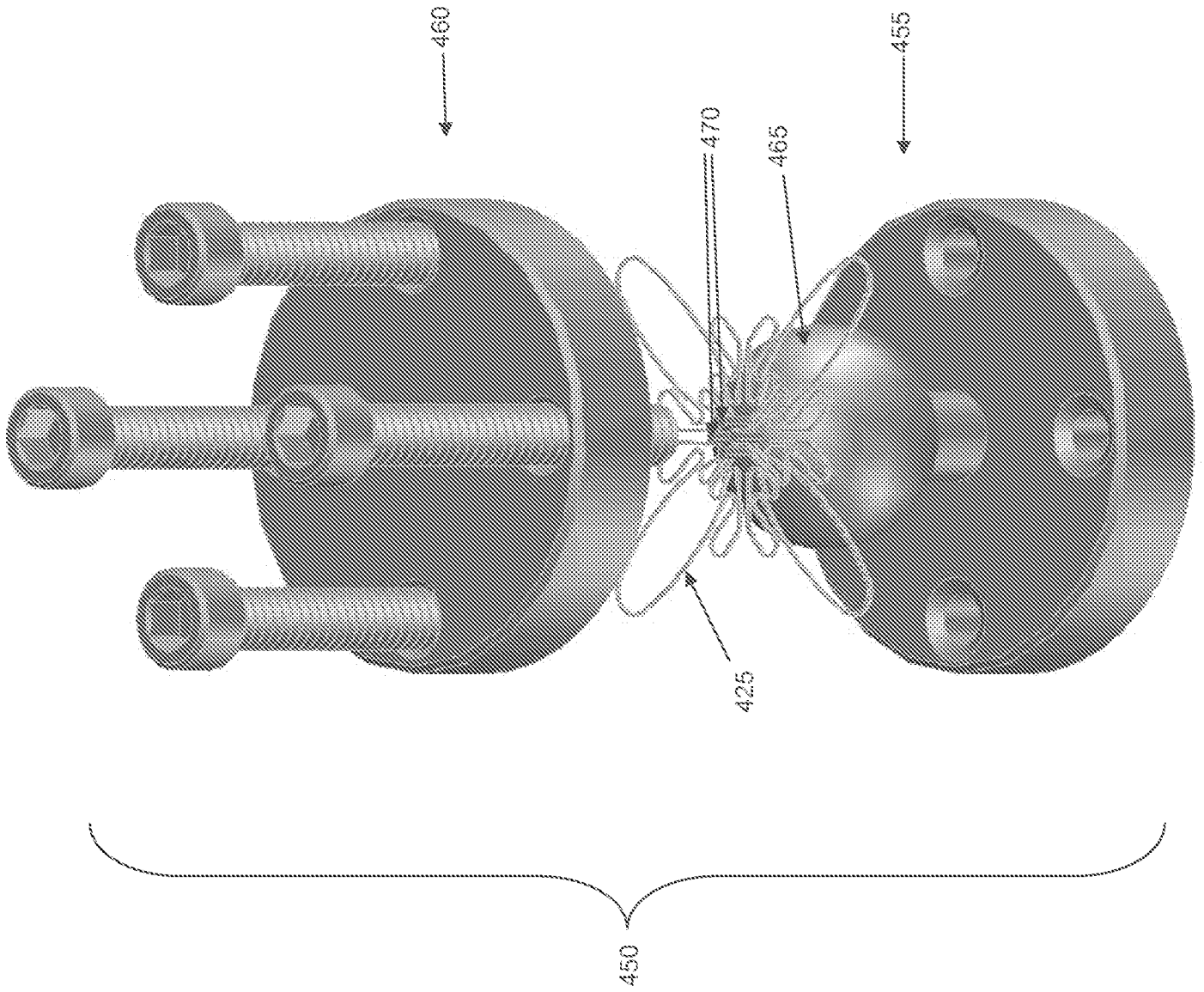

FIG. 120

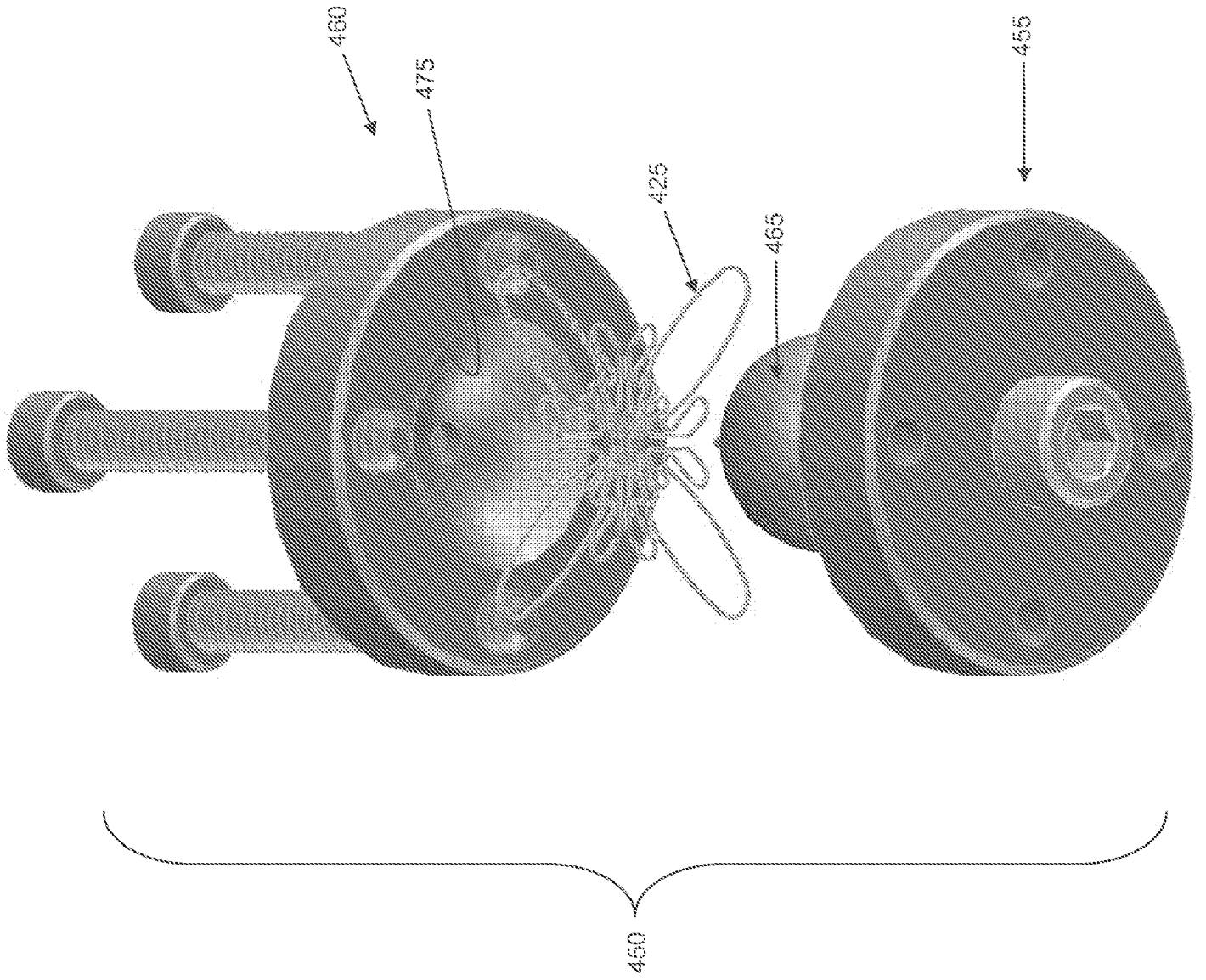

FIG. 121

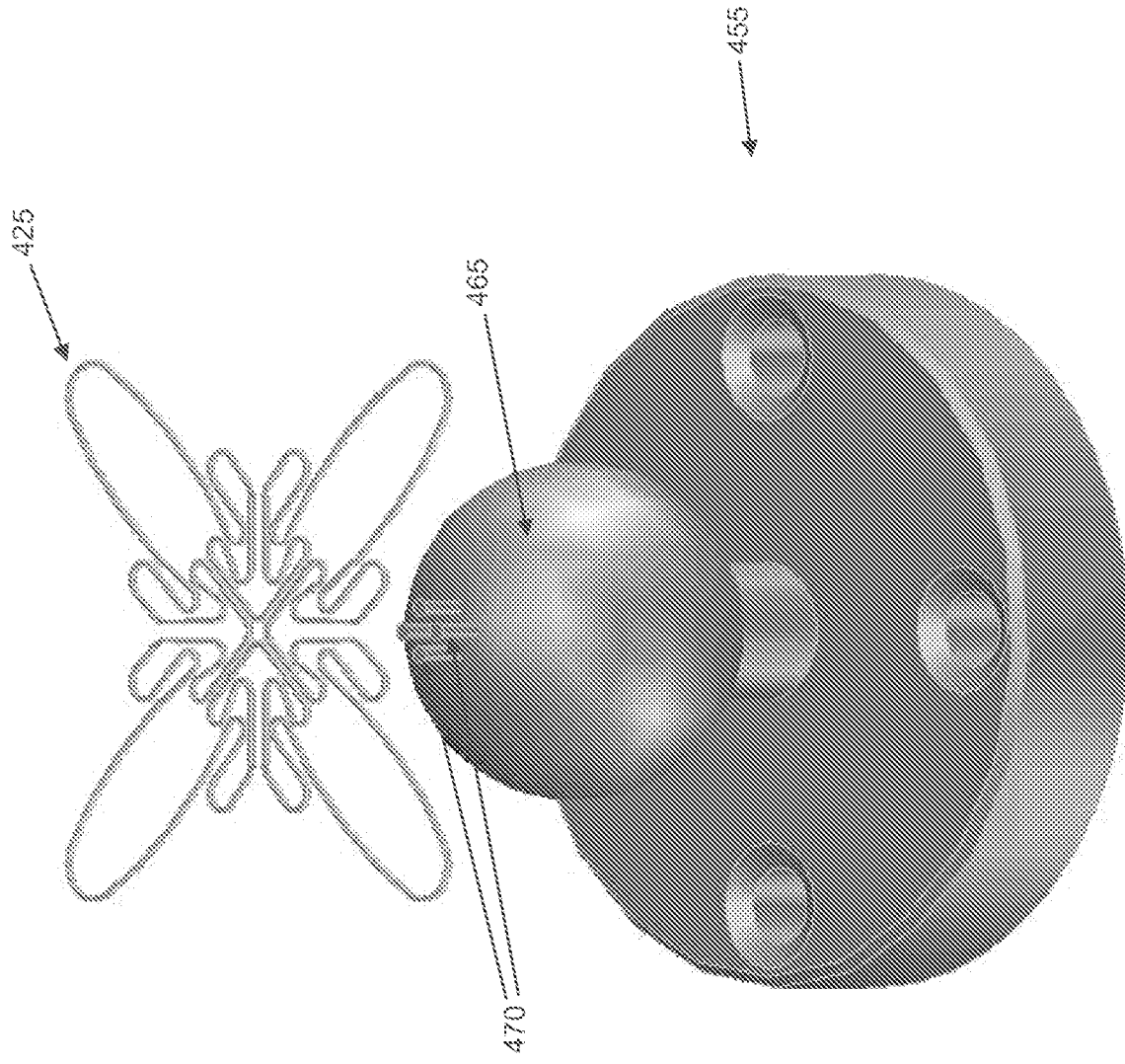

FIG. 122

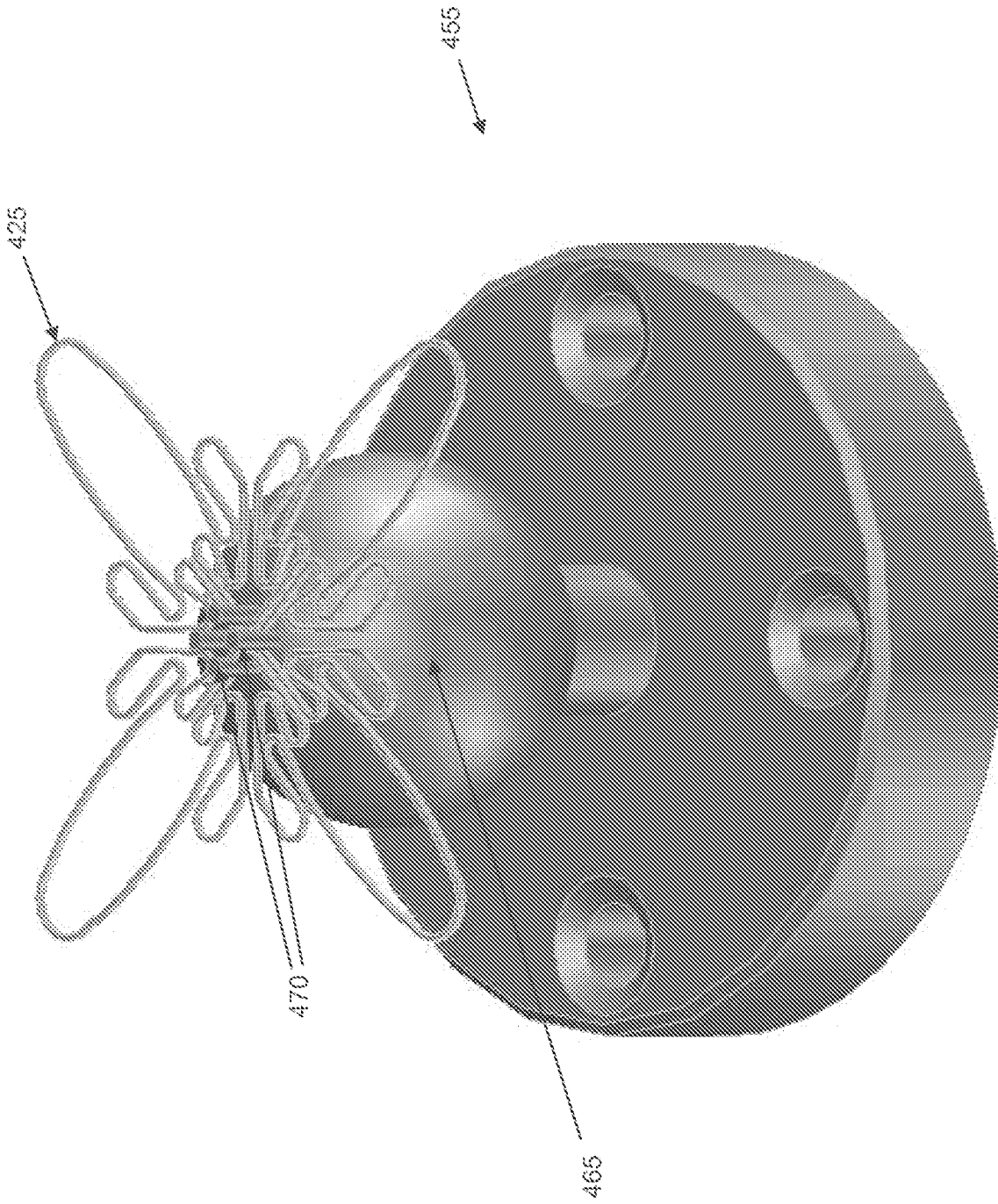

FIG. 123

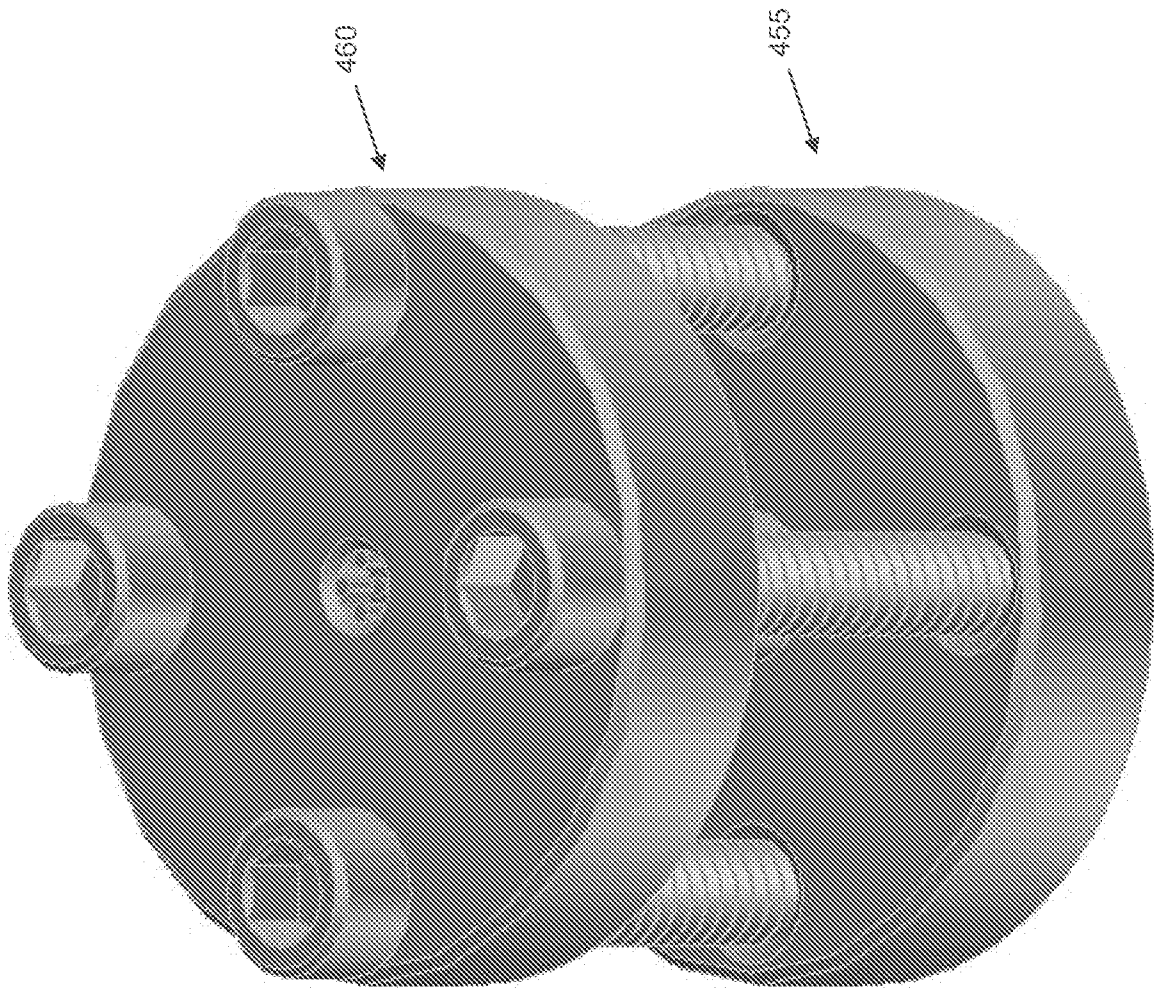

FIG. 124

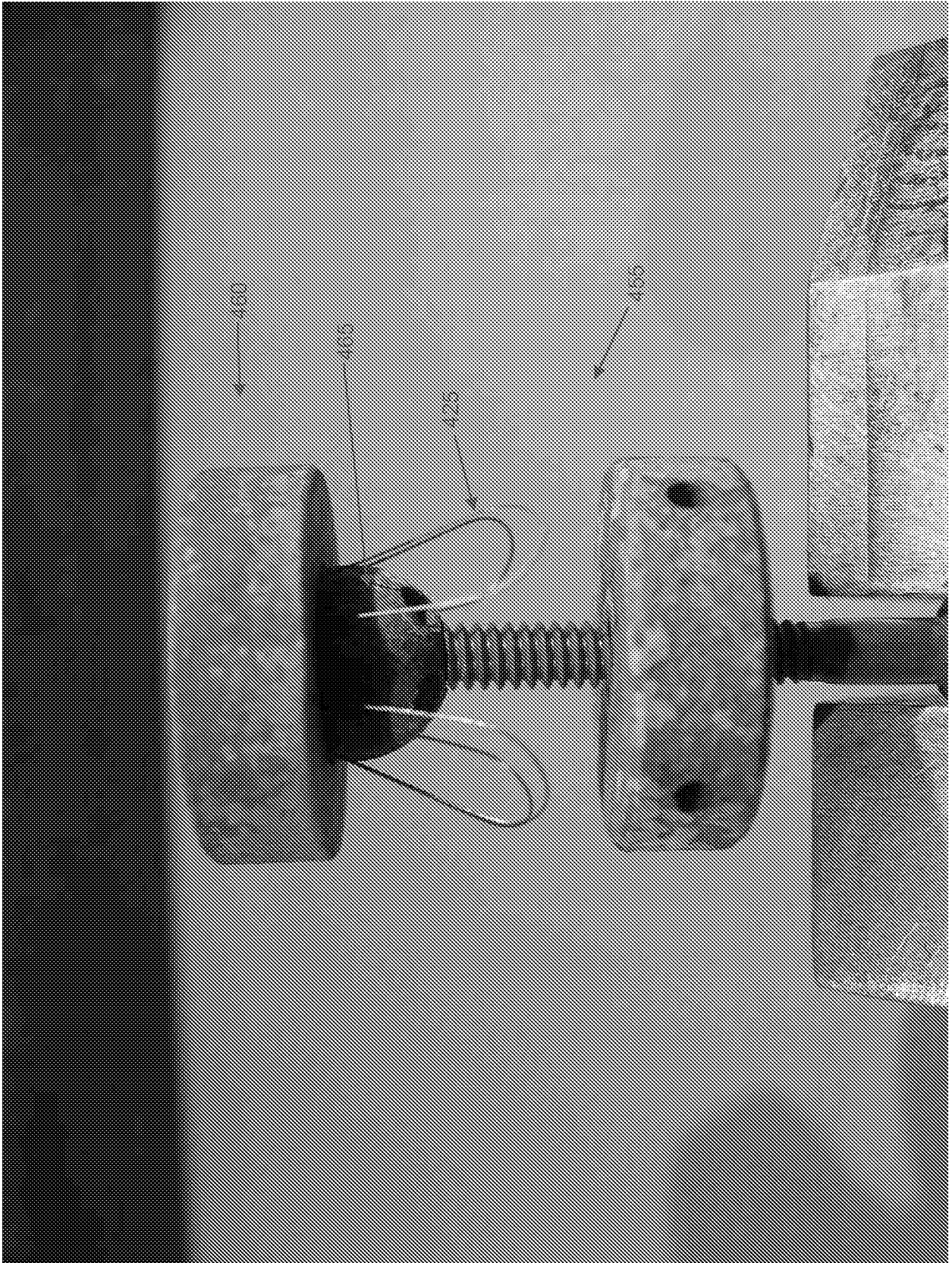

FIG. 125

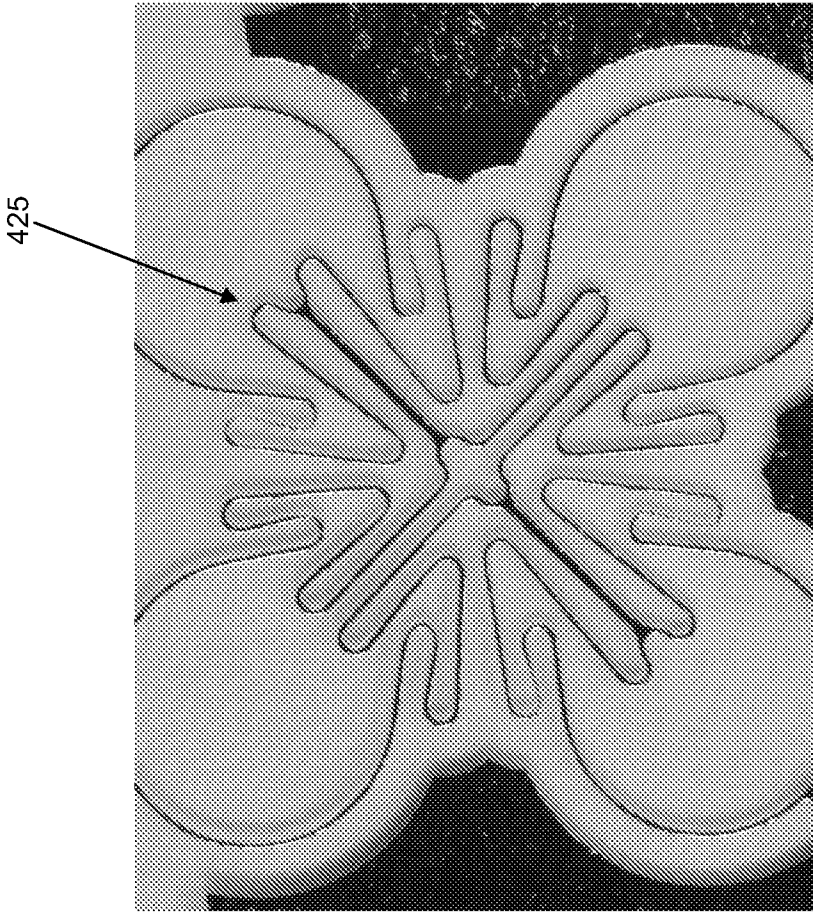

FIG. 127

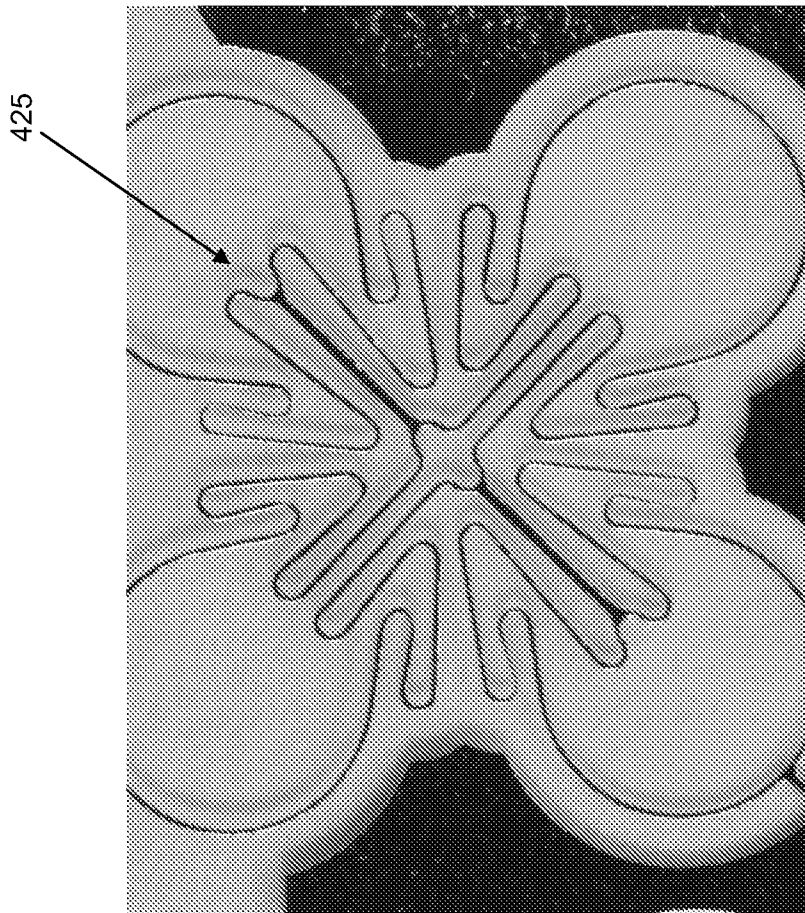

FIG. 126

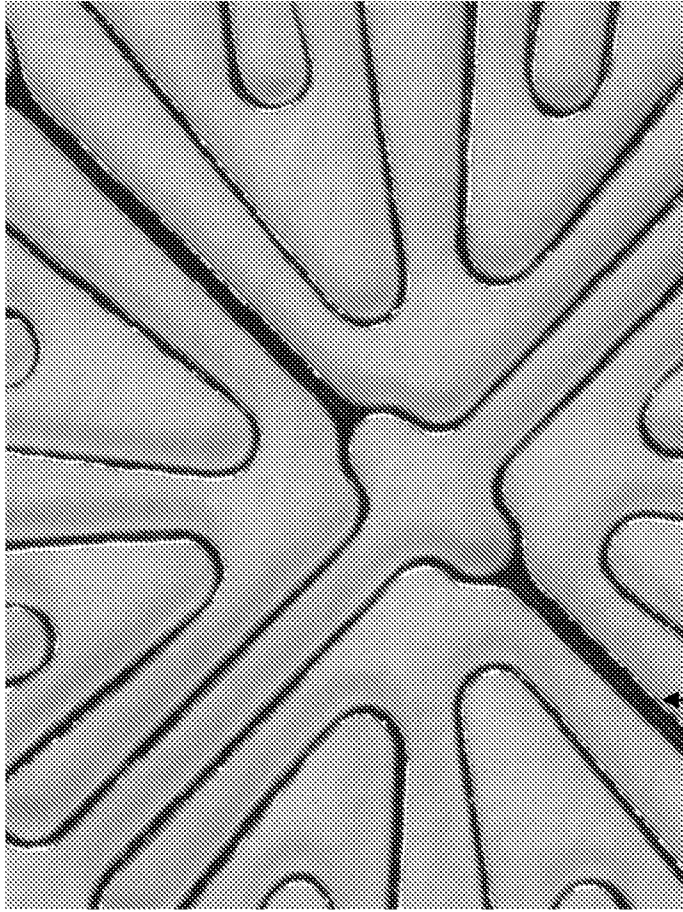

FIG. 129

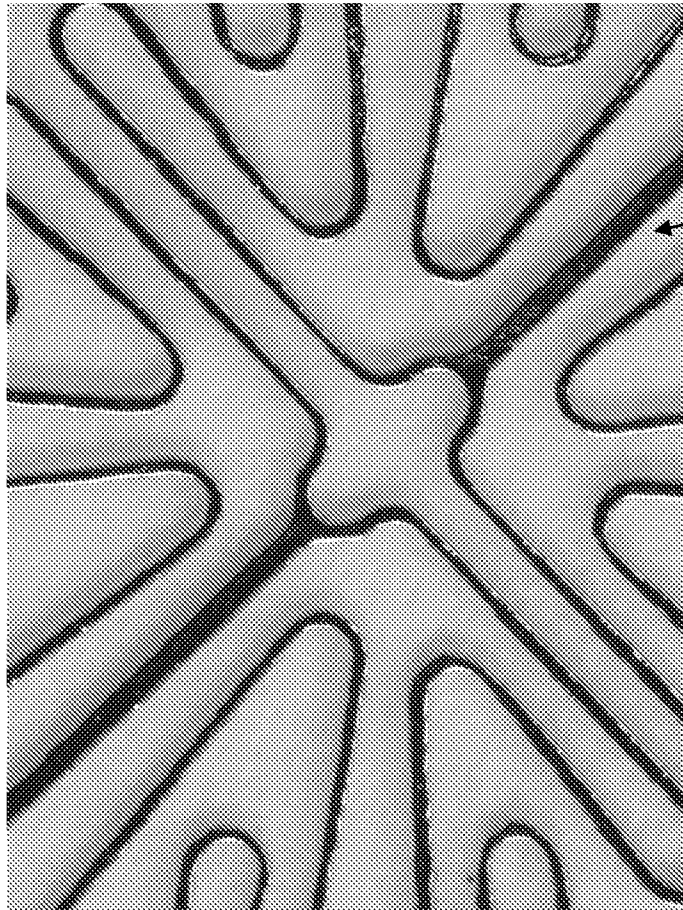

FIG. 128

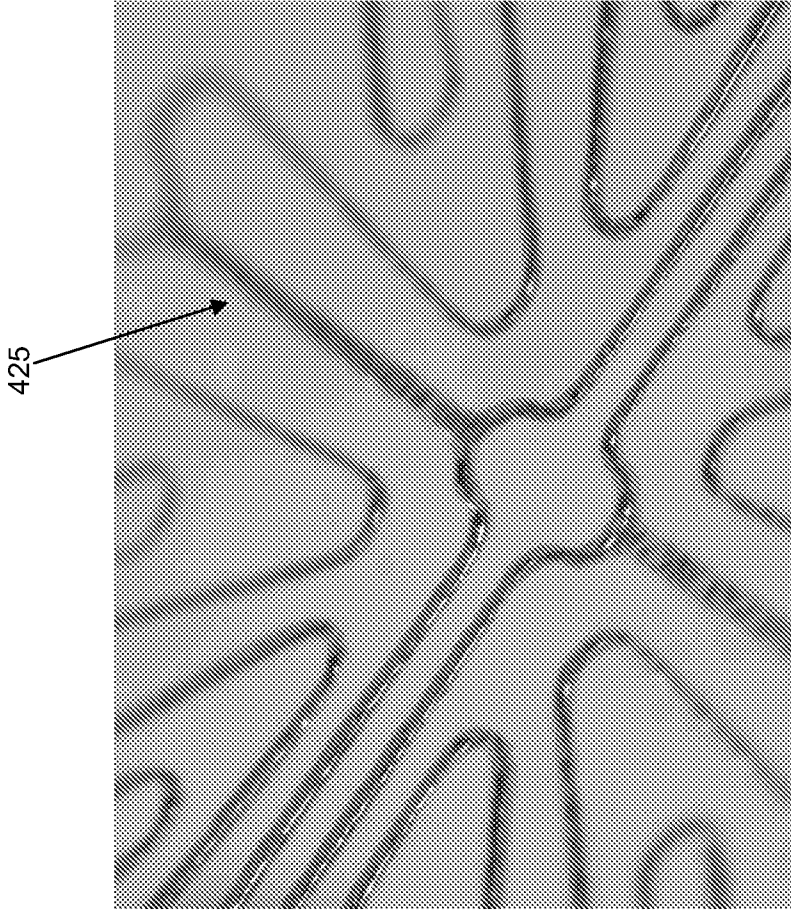

FIG. 131

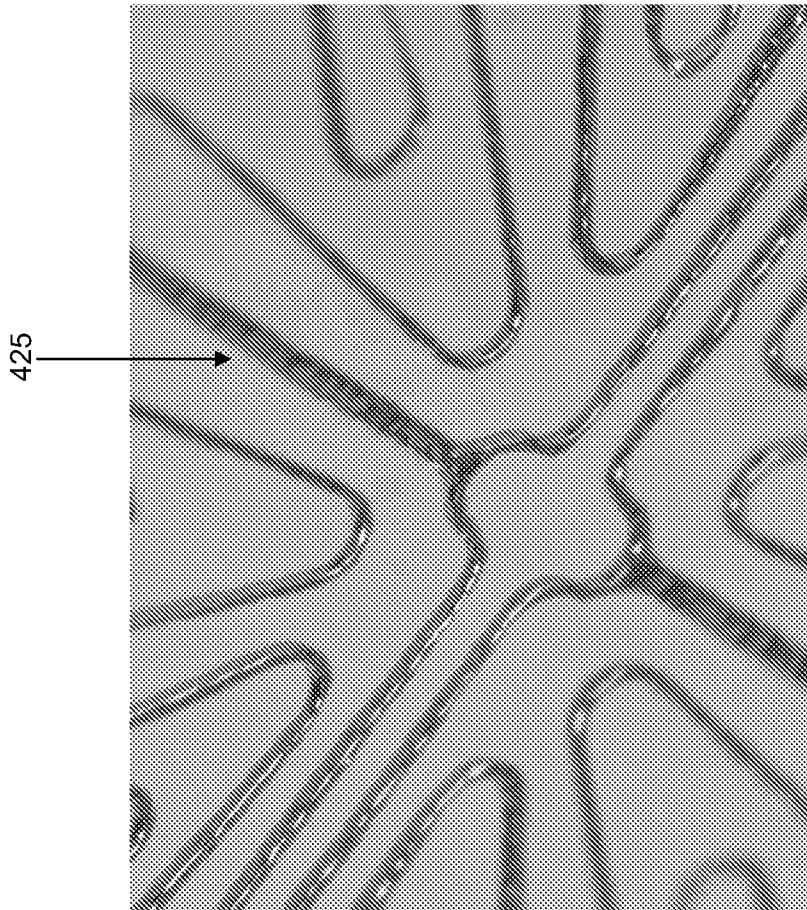

FIG. 130