

W. H. STICKEL.
Carriage-Top Prop.

No. 67,371.

Patented July 30, 1867

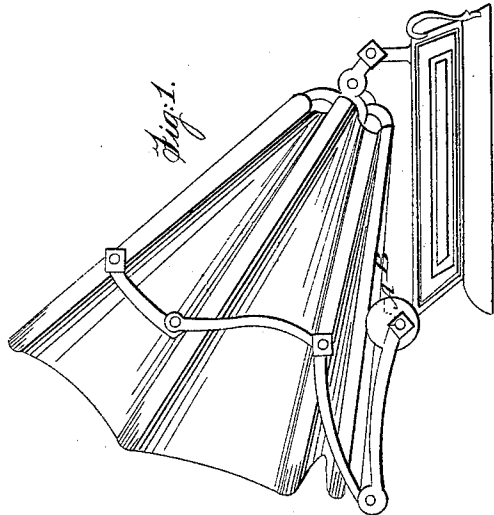
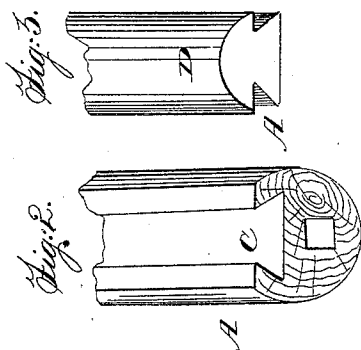

Witnesses
Thea Busche
W. Sprengel

Inventor
W. H. Stickel
Per *[Signature]*
Attorney

United States Patent Office.

W. H. STICKEL, OF KNIGHTSTOWN, INDIANA.

Letters Patent No. 67,371, dated July 30, 1867.

IMPROVEMENT IN PROP-BLOCK FOR CARRIAGE TOPS.

The Schedule referred to in these Letters Patent and making part of the same.

TO ALL WHOM IT MAY CONCERN:

Be it known that I, W. H. STICKEL, of Knightstown, Henry county, Indiana, have invented a new and improved "Prop-Block for Buggies and other Carriages;" and I do hereby declare that the following is a full, clear, and exact description thereof, which will enable others skilled in the art to make and use the same, reference being had to the accompanying drawings, forming part of this specification.

Figure 1 represents a side view of a buggy top having my improved prop-blocks, and Figures 2 and 3 detail views, showing construction of prop-blocks.

The present invention consists in having the bearing surfaces of the prop-blocks to the tops of buggies and other carriages, when thrown back, of India rubber, whereby injury to the top from friction is not only prevented, but the jar of the same when thrown back prevented, and a much easier riding of the buggy top when resting on its prop-block secured.

A, in the drawings, represents the prop-blocks to a buggy top, and on which the bars B of the top rest when it is thrown back into the position shown in fig. 1. These blocks are constructed with a dove-tail groove, C, shown in fig. 2, to receive a corresponding dove-tail shaped strip, D, shown in fig. 3, which strip forms the bearing surface of the prop-blocks, and is to be made of elastic India rubber, so as to prevent any jar to the top when thrown back upon its prop-blocks; also to secure a more easy riding of the top when in such position, as well as to greatly prevent wear, etc.

Having thus described my invention, what I claim as new, and desire to secure by Letters Patent, is—

The prop-block A, when provided with the dove-tailed groove *e*, adapted to receive the corresponding dove-tailed elastic removable strip D, operating as described for the purpose specified.

The above specification of my invention signed by me this day of

, 1867.

W. H. STICKEL.

Witnesses:

JOHN VANPELT,
R. D. BARRY.