

1 574 811

- (21) Application No. 5213/76
- (22) Filed 10 Feb. 1976
- (23) Complete Specification Filed 24 Jan. 1977
- (44) Complete Specification Published 10 Sep. 1980
- (51) INT. CL.³ D01H 5/88
- (52) Index at Acceptance
D1D 801 HA

(19)



(54) TWO-BAND TEXTILE FIBRE DRAFTING APPARATUS

5 (71) I, JOHN MICHAEL NOGUERA, a British subject, of 1, Greville House, Kinnerton Street, London, S.W.1., do hereby declare the invention for which we pray that a patent may be granted to us, and the method by which it is to be performed, to be particularly described in and by the following statement:-

10 This invention relates to two-band textile fibre drafting apparatus of the type having superposed endless bands respectively supported by separate upper and lower front tensors and rear driving rollers and guided laterally by side walls of an upper cradle carrying the upper tensor and side walls of a separate lower cradle which provides support for the lower tensor.

15 Apparatus of this known type has already been proposed in which the maximum permitted delivery opening between tensors is determined by hooking the forward end of the upper cradle, the rear end of which bears against the upper roller, under downwardly directed lateral abutments on an interchangeable and/or adjustable platform-like lower tensor. The platform-like lower tensor is, in turn, arranged to rest at its forward edge on upwardly directed abutments on the lower cradle and has the rear edge trapped by undercut slots in the lower cradle side walls. By making such undercut slots rather deeper than necessary for operating purposes, the platform-like tensor can slide rearwardly therein, when the upper cradle is uncoupled therefrom, so as to relieve the lower band tension. This tension in the lower band is then automatically reapplied when the upper cradle is recoupled in the operative position.

20 The foregoing known arrangement has proved highly effective for its intended purpose, but it has the limitation of requiring considerable accuracy of band size for optimum performance. If, in practice, the bands are slightly undersize or oversize, the

degree of tension therein tends correspondingly to increase or decrease with adverse affect on the drafting conditions.

According to the present invention there is provided a two-band textile fibre drafting apparatus having superposed endless bands respectively supported by separate upper and lower front tensors and rear driving rollers and guided laterally by side walls of an upper cradle carrying the upper tensor and side walls of a separate lower cradle which provides support for the lower tensor. the upper cradle being arranged, at the rear end, to bear against the upper roller and, at the front end, to hook under downwardly directed lateral abutments on the lower tensor which is of platform-like form, and the lower tensor being operatively positioned by the lower cradle only at the forward lower tensor edge which edge is supported by upwardly directed lower cradle abutments, the downwardly directed lower tensor abutments being set back from the supported lower tensor edge to an extent such that the action of the upper cradle thereon tends to lift the rear lower tensor end, to an extent depending on the band size, i.e. on the overall length of the band, to maintain the bands in a yieldingly tensioned condition. Apparatus as just defined has the facility for delivery adjustment of known apparatus, and provides gentle and yielding tensioning action on the bands.

For a better understanding of the invention and to show how the same may be carried into effect reference will now be made, by way of example, to the accompanying drawings, in which the three Figures are three similar side views of three different forms of drafting apparatus.

Figure 1 shows apparatus of the known type having three consecutive roller lines, the rear roller line being composed of upper and lower holding rollers 1, the intermediate roller line being composed of upper and

45

50
55
60
65
70
75
80
85
90

lower band-driving rollers 2A, 2B, while the front roller line is composed of upper and lower drawing rollers 3. Carried by the respective band-driving rollers 2A, 2B are two co-operating superposed endless bands 4, 5 having adjoining runs 4A, 5A between which textile fibres are guided, and controlled during their passage from the holding rollers 1 to the drawing rollers 3. At their forward ends, the bands 4, 5 are supported by separate upper and lower tensors 6, 7 which will later be referred to in more detail.

For the purpose of guiding the bands 4, 5 laterally, there are provided separate upper and lower cradles 8, 9 having approximately equally spaced lateral guide walls 8A, 9A so that the cradles will be substantially in edge-to-edge relationship when operatively positioned. The side walls 9A of the lower cradle 9 are provided with downwardly directed registering slots 10 for engaging around necks at opposite ends of the bottom band-driving roller 2B and rearwardly of these slots, are joined by a transverse tie bar 11. Towards the rear end, the upper edges of the lower cradle side walls 9A are also upwardly extended to bear, at 12, behind necks on the upper driving roller 2A in generally known manner. In front of these upward extensions the upper edges of the lower cradle side walls 9A are shaped so as approximately to follow the contours of the lower edges of the upper cradle side walls 8A. Towards their forward ends the lower cradle side walls 9A are formed with upwardly open recesses 13 which conform with downwardly extending side wall portions 8A' at the forward end of the upper cradle 8. The lower cradle side wall recesses 13, which are in register, are provided each with a shallow depression 13A at the rear end and terminate, at their forward ends, in upstanding fingers 13B providing upwardly directed abutments.

The lower tensor 7 is in the form of a broad platform-like bar member having a convex upper surface from front to rear and arranged to extend across the inside of the lower band 5 to support the operative band run 5A. This lower band 5 returns around the front or leading edge of the lower tensor 7 to form the lower part of a delivery opening 14 at the outlet end of the co-operating band runs 4A, 5A. The operative lower band run 5A is more or less deflected, depending upon the radius of curvature of the lower tensor platform 7, into a shallow arcuate path in passing over the lower tensor 7. To locate the lower tensor 7 in relation to the lower cradle 9, when the lower band 5 is in a non-tensioned inoperative condition, lateral lugs 7A which project from the rear ends of the lower tensor side edges are arranged to enter the shallow

depressions 13A, in the lower cradle side wall recesses 13, and engage with the side walls 9A. At the same time lateral flaps 7B provided at the forward ends of the lower tensor side edges rest on the upwardly directed abutments provided by the tops of the upstanding fingers 13B. These flaps 7B are also rearwardly and downwardly extended to provide downwardly directed lateral abutments 7B' on the lower tensor 7 which are set back from the supported forward lower edge of the tensor 7 and serve to inter-engage the forward ends of the upper cradle side walls 8A as will be later explained.

The upper tensor 6 is in the form of a cross-piece which is fixed between the upper cradle side walls 8A so as to join these walls rigidly together. The forward edge of this tensor 6 is rounded and the front end of the upper band 4 returns therearound to form the upper part of the delivery opening 14 between the co-operating band runs 4A, 5A. The cross-piece forming the upper tensor 6 is arched or angled away from the operative run 4A of the upper band 4, so that the only contact between the upper band 4 and the upper tensor 6 is at the upper tensor forward edge.

The rear end edges of the upper cradle side walls 8A have arcuate recesses 15 formed therein for bearing against the upper roller necks at positions opposed to the upward extensions on the lower cradle side walls 9A which bear behind the upper roller necks at 12. The front edges of the upper cradle side walls are also recessed to form forwardly projecting hooks 8B at the lower recess ends which can be engaged beneath the downwardly directed lateral abutments 7B' on the lower tensor flaps 7B for the purpose of holding down the upper cradle 8 in the operative position. When thus engaged, the lower tensor 7 is also urged forwardly within its band run 5A, thus tensioning the band.

Figure 2 shows a first embodiment of the invention in its working position. The distance by which the downwardly directed abutments 7B' on the lower tensor 7 which engage the hooks 8B on the upper cradle 8 are set back from the supported forward edge of the lower tensor 7 is chosen so as to provide a suitable leverage whereby the action of the upper cradle 8 on the lower tensor 7 is to lift the rear edge of the lower tensor 7 upwards as far as the band size will permit. The lower tensor 7 can readily be designed so that the position of the laterally disposed downwardly directed abutments 7B' gives exactly the degree of band tension which is considered best for satisfactory operation. Thus small variations in band size can be readily accommodated in an extremely yielding manner and whilst main-

70

75

80

85

90

95

100

105

110

115

120

125

130

taining a substantially constant tension.

It is, of course, also possible for the lower tensor 7 to be interchanged to enable tensors of different curvatures or shapes and different abutment settings to be employed, this being illustrated by the alternative configurations illustrated in the Figures. In the form of Figure 2, for example, the downwardly directed abutments on the lower tensor are set back from the front tensor edge by an amount approximately equal to one third of the tensor width from front to rear edge. The extent of set-back will, however, depend on individual drafting conditions and may be varied to provide greater or less leverage as desired. In *Figure 3* a second embodiment of the Invention is shown which is intended for drafting longer fibres and has correspondingly longer bands and correspondingly modified tensors. In this form the downwardly directed abutments on the lower tensor are disposed close to the centre of the tensor between the front and rear edges.

WHAT I CLAIM IS:-

1. A two-band textile fibre drafting apparatus having superposed endless bands respectively supported by upper and lower front tensors and rear driving rollers and guided laterally by side walls of an upper cradle carrying the upper tensor and side walls of a separate lower cradle which provides support for the lower tensor, the upper cradle being arranged, at the rear end, to bear against the upper roller and, at the front end, to hook under downwardly directed lateral abutments on the lower tensor which is of platform-like form, and the lower tensor being operatively positioned by the lower cradle only at the forward lower tensor edge which edge is supported by upwardly directed lower cradle abutments, the downwardly directed lower tensor abutments being set back from the supported lower tensor edge to an extent such that the action of the upper cradle thereon tends to lift the rear lower tensor end, to an extent depending on band size, to maintain the bands in a yielding tensioned condition.

2. Apparatus as claimed in claim 1, wherein further downwardly directed lower tensor abutments are provided laterally displaced from the first-mentioned lower tensor abutments and projecting further downwardly whereby, by sliding the lower tensor transversely in the lower cradle and engaging the upper cradle abutments with a selected pair of alternative pairs of lower tensor abutments the tensor spacing can be selected.

3. Apparatus as claimed in claim 1 or 2, wherein the lower tensor is interchangeable with alternative lower tensors of different curvatures or shapes.

4. Apparatus as claimed in claim 1, 2 or 3, wherein the lower tensor is provided with rear lateral lugs arranged to engage the lower cradle side walls, in the non-tensioned inoperative condition of the bands, to locate the lower tensor in relation to the lower cradle.

5. Apparatus as claimed in claim 1, 2, 3 or 4, wherein the upper tensor is in the form of a cross-piece fixed between the upper cradle side walls so as to join these walls rigidly together.

6. A two-band textile fibre drafting apparatus substantially as hereinbefore described with reference to Figure 2 or Figure 3 of the accompanying drawings.

JOHN M. NOGUERA,
Applicant.

Printed for Her Majesty's Stationery Office,
by Croydon Printing Company Limited, Croydon, Surrey, 1980.
Published by The Patent Office, 25 Southampton Buildings,
London, WC2A 1AY, from which copies may be obtained.

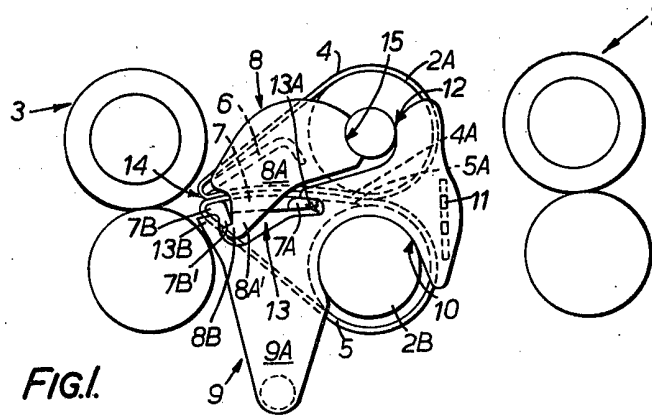

FIG. 1.

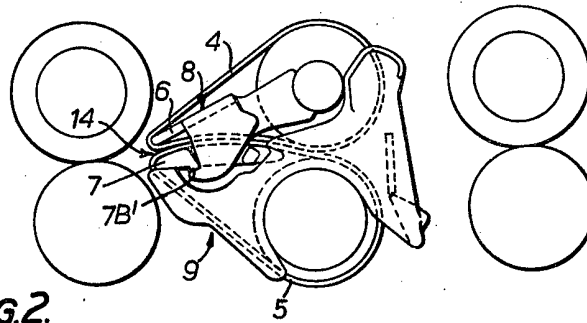

FIG. 2.

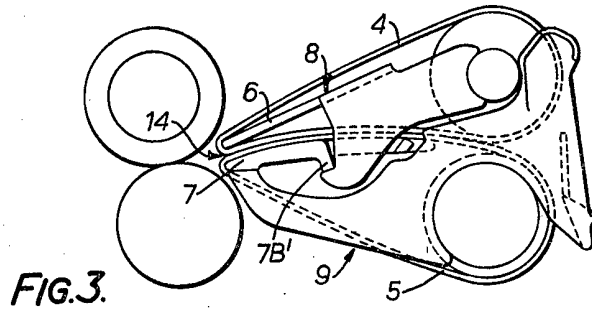

FIG. 3.