

(19) AUSTRALIAN PATENT OFFICE

(54) Title
Mast construction for a lift truck

(51)⁶ International Patent Classification(s)
B66F 009/08

(21) Application No: **2004203582** (22) Application Date: **2004.08.05**

(30) Priority Data

(31) Number	(32) Date	(33) Country
10/634,377	2003.08.05	US 7

(43) Publication Date : **2005.02.24**

(43) Publication Journal Date : **2005.02.24**

(71) Applicant(s)
The Raymond Corporation

(72) Inventor(s)
Lewis, Robert; West, John A

(74) Agent/Attorney
PIZZEYS, ANZ Centre Level 14 324 Queen Street, Brisbane, QLD, 4000

MAST CONSTRUCTION FOR A LIFT TRUCK

ABSTRACT OF THE DISCLOSURE

A mast includes a base section (126), an outer telescopic section (128) and an inner telescopic section (130) which are raised and lowered by a pair of main lift cylinders (172, 174). A fork carriage (124) is slidably mounted to the inner telescopic section (130) and is raised and lowered thereon by a pair of free lift cylinders (160, 162). The mast elements are arranged to form two mast columns which produce minimum obstruction to the truck operator's field of view when looking forward through the mast.

Fig. 4B

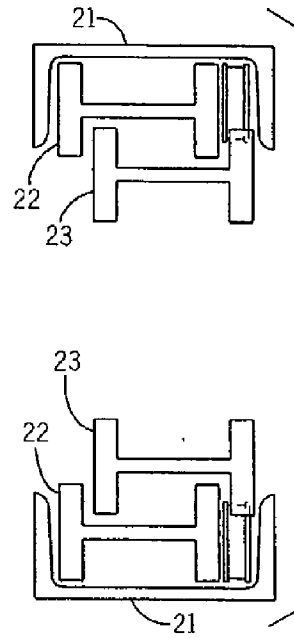
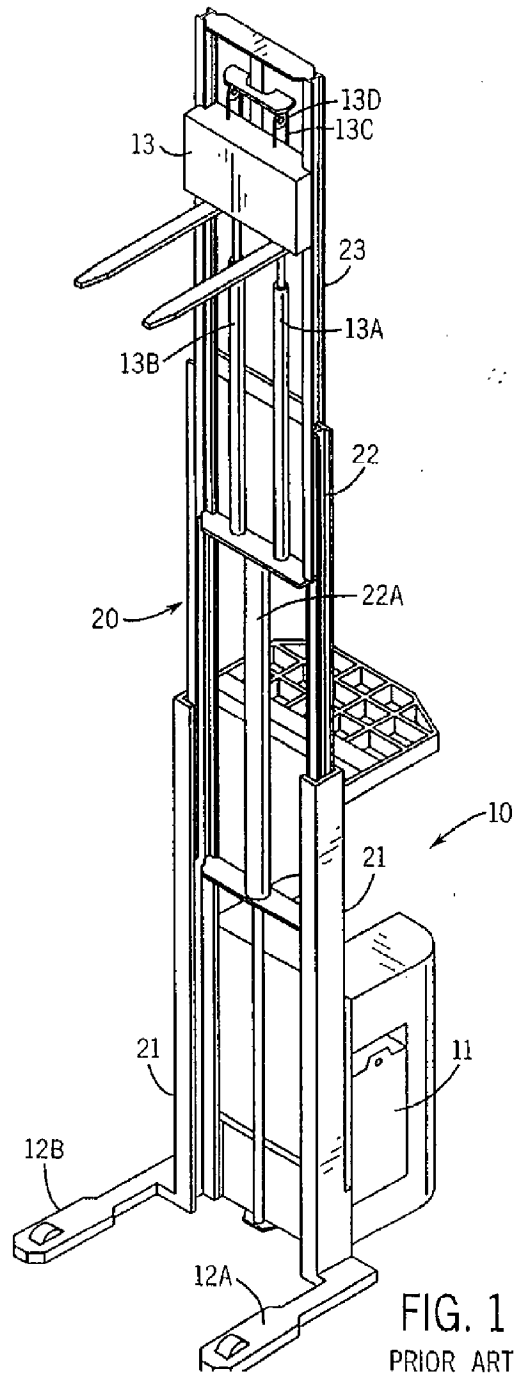

FIG. 2
PRIOR ART

MAST CONSTRUCTION FOR A LIFT TRUCK

DEFINITIONS

[0001] In the specification the term "comprising" shall be understood to have a broad meaning similar to the term "including" and will be understood to imply the inclusion of a stated integer or step or group of integers or steps but not the exclusion of any other integer or step or group of integers or steps. This definition also applies to variations on the term "comprising" such as "comprise" and "comprises".

BACKGROUND OF THE INVENTION

[0002] The field of the invention is industrial lift trucks, and particularly the telescopic masts for such trucks.

[0003] A lift truck typically is a battery powered vehicle having an operator compartment with controls that enable the operator to drive the truck and to hoist materials and carry them quickly throughout a factory or warehouse. An upright telescopic mast is attached to the forward end of the truck and a carriage, or forks, supporting materials can be hoisted by extending the telescopic mast upward.

[0004] An exemplary lift truck is shown in Figs. 1 and 2. It includes an operator compartment 10, a battery 11 and outriggers, or baselegs, 12A and B. A three section, telescopic mast 20 attaches to the front of the truck and includes a base section 21 and two telescopic sections 22 and 23. As shown best in Fig. 2, the lower telescopic section 22 (referred to in the art as the "outer" telescopic section) is nested within the base section 21 and the higher telescopic section 23 (referred to in the art as the "inner" telescopic section) is nested inward of the outer telescopic section 22.

[0005] A fork carriage 13 is slidable mounted to the inner telescopic section 23 and it is moved up and down thereon by carriage free lift cylinders 13A and B via chains 13C which pass over pulleys 13D. The outer telescopic section 22 is moved relative to the base section 21 by a main lift cylinder 22A located midway between the left and right mast sections. Lift chains (not shown in Figs. 1 and 2) fastened to the base section 21, extending over pulleys at the top of the outer telescopic section 22, and fastened to the bottom end of the inner telescopic section 23 provide a simultaneous and coordinated movement of the inner telescopic section 23 relative to the outer telescopic section 22.

Operation of the main lift cylinder 22A using controls in the operator compartment 10 may thus extend or contract the two telescopic sections 22 and 23. Operation of the carriage free lift cylinders 13A and B from the operator compartment 10 also controls the precise height of the fork carriage 13.

[0006] These mast elements plus the associated hydraulic hoses provide obstructions which limit the operator's field of view when looking forward towards the forks from the operator compartment 10. This is particularly true when the mast is lowered and all the cylinders 22A, 13A and 13B are disposed directly in front of the operator.

[0007] Many efforts have been made to improve the operators field of view when looking forward through the mast. These include shortening the main lift cylinders as disclosed in U.S. Pat. Nos. 4,191,276 and 4,261,438 so that it does not obstruct view when the mast is lowered, shifting the location of the main lift cylinder to one side as disclosed in U.S. Pat. No. 4,355,703; shifting the location of the single main lift cylinder to one side and shifting a single carriage free lift cylinder to the other side as disclosed in U.S. Pat. No. 4,506,764; and shifting the location of the two carriage free lift cylinders to locations nearer the mast uprights to increase visibility as described in U.S. Pat. Nos. 4,369,861; 4,365,693; 4,030,568 and 4,441,585. Yet another approach disclosed in U.S. Pat. No. 4,585,093 is to locate the two carriage free lift cylinders substantially behind the mast uprights and provide two main lift cylinders which are also behind the respective mast uprights. This is carried one step further in U.S. Pat. No. 6,505,710 in which the two main lift cylinders are formed into the base section of the mast.

[0008] A significant constraint on the design of a lift truck mast structure is its fore to aft dimension. The length of a lift truck is a very important characteristic of a lift truck, since turning radius is directly related to length. The productivity of a truck and operator is directly related to the turning radius of the truck since in the tight confines of factories and warehouses a smaller turning radius translates to less back-and-forth jockeying of the truck. The elimination of one or more inches in the length of a truck therefore has significant economic significance.

SUMMARY OF THE INVENTION

[0009] The present invention is a telescopic mast for a lift truck in which the mast elements and associated lift elements are arranged to maximize the operator's field of view

when looking forward from the operator compartment. More specifically, the mast includes: a base section having a pair of spaced upright baseleg members attached to the lift truck; an outer telescopic section having a pair of spaced upright midleg members slidably attached to the pair of baseleg members and disposed laterally inward therefrom; an inner telescopic section having a pair of spaced upright top leg members slidably attached to the pair of midleg members and disposed laterally inward therefrom; a pair of lift chain pulleys one mounted to the upper end of each midleg member and disposed forward of the top leg members; a pair of lift chains, one disposed over each of the lift chain pulleys and having one end connected to the baseleg member and a second end connected to the top leg member; and a pair of main lift cylinders connected between the base section and the outer telescopic section and being disposed behind the two mast columns formed by the mast sections, the main lift cylinders being operable to extend the mast upward by sliding the outer telescopic section with respect to the base section.

[0010] A general object of the invention is to maximize the operator's field of view when looking forward through the mast from an operator's compartment. By nesting the midleg members in the baseleg members and mounting the lift chain pulleys forward of the top leg members, the two obstructing profiles of the mast columns are minimized when viewed from the operator compartment.

[0011] Another aspect of the invention is the arrangement of the main lift cylinders and a pair of free lift cylinders. The free lift cylinders are mounted to the top leg members and positioned substantially behind the mast columns and laterally inward from the main lift cylinders. Operation of the free lift cylinders raises and lowers a carriage slidably mounted to the inner telescopic section. The lateral location of the free lift cylinders is asymmetric with respect to the truck center line to provide clearance for a hose pulley which the left cylinder supports without reducing operator visibility.

BRIEF DESCRIPTION OF THE DRAWINGS

[0012] Fig. 1 is a perspective view of a typical prior art lift truck;

[0013] Fig. 2 is a cross-sectional view through the mast of the prior art lift truck in Fig. 1;

[0014] Fig. 3 is a side elevation view of a lift truck which employs the present invention;

[0015] Figs. 4A and 4B are perspective views of the mast structure of the lift truck of Fig. 3;

[0016] Figs. 5A, 5B and 5C are perspective views of the respective base section, outer telescopic section and inner telescopic section of the mast structure of Fig. 4;

[0017] Fig. 6 is a partial top plan view of the lift truck of Fig. 3 showing the arrangement of mast elements according to a preferred embodiment of the invention;

[0018] Fig. 7 is a top view of the lift truck of Fig. 3 with sight lines indicating the operator's field of view through the mast structure;

[0019] Fig. 8 is a perspective view of the inner telescopic section with attached free lift cylinders, and

[0020] Fig. 9 is a partial perspective view of the inner telescopic section with slidably mounted fork carriage.

DETAILED DESCRIPTION OF THE PREFERRED EMBODIMENT

[0021] Referring particularly to Fig. 3, a lift truck which employs a preferred embodiment of the invention includes a power unit 110 having an operator's compartment 112 located to the rear and a battery compartment 114 located at the forward end. The battery supplies power to a traction motor drive (not shown) which rotates a steerable drive wheel 116 to propel and steer the lift truck. A pair of laterally spaced base legs 118 connect to, and extend forward from the power unit 110, and each base leg includes wheels 120 which support the truck.

[0022] A mast 122 connects to the front end of the power unit 110 and extends vertically upward therefrom. The mast 122 supports a fork carriage 124 which can be elevated to different heights as will be described in detail below. The mast 122 is comprised of three telescopic sections which are shown best in Figs. 4A and 4B. These include a base section 126, an outer telescopic section 128, and an inner telescopic section 130. Rollers mounted to the sections 126, 128 and 130 enable those sections to slide with respect to each other to allow the mast to be raised and lowered. These mast elements form two spaced mast columns which block the operator's view when looking forward from the operator compartment. It is an objective of this design to reduce the profile of these mast columns and the associated mast elements to maximize the operator's forward field of view.

[0023] As shown best in Fig. 4A, the base section 126 is comprised of a pair of spaced, upright baselegs 132 and 134 connected together at their bottom ends by a base crosstie 136 and at their upper ends by a pair of crossties 138 and 140. The crossties 138 and 140 include a set of louvers which provide the desired structural rigidity and which are oriented at an angle which minimizes obstruction of the operator's view. The crosstie 140 also serves to support a protective guard 142 (see Fig. 3) above the operator. The base crosstie 136 attaches to the front of the power unit 110 and serves as a means for fastening the mast structure to the power unit 110.

[0024] Referring particularly to Fig. 5B, the outer telescopic 128 is comprised of a pair of spaced, upright midlegs 144 and 146 connected at their lower ends by a lower crosstie 148. An upper crosstie 150 extends rearward from the upper ends of the midlegs 144 and 146 and then laterally across the space between the midlegs 144 and 146 to maintain their parallel alignment. The rearward extending portions of the crosstie 150 also provides a connection point for a pair of main lift cylinders to be described in more detail below.

[0025] Referring particularly to Figs. 5C and 8, the inner telescopic section 130 is comprised of a pair of spaced, upright top legs 152 and 154 connected at their lower ends by a lower crosstie 156 and connected at their upper ends by an upper crosstie 158. Upper crosstie 158 extends rearward and presents a horizontal platform having openings therein which enable the upper ends of a pair of free lift cylinders 160 and 162 to extend. The lower ends of free lift cylinders 160 and 162 mount to ears 164 and 166 that extend rearward from the top legs 154 and 152 adjacent the lower crosstie 156. The upper cylinder ends connect to a rear flange 202 of the top legs 152 and 154 near their top ends. As will be described in detail below, the free lift cylinders 160 and 162 are hydraulically operated in response to commands from the operator to extend and retract rods 168 and 170 to raise and lower the fork carriage 124 that is slidably mounted to the top legs 152 and 154.

[0026] Referring particularly to figs. 8 and 9, free lift chain pulleys 171 and 173 are mounted to the top ends of the respective free lift cylinder rods 168 and 170. Free lift chains 175 and 177 extend over the respective pulleys 171 and 173 and one end of each chain is anchored to the rear side of respective free lift cylinders 160 and 162. The other end of each free lift chain drapes down the front side of their respective cylinders 160 and

162 and attaches to the back of the fork carriage 124. When the rods 168 and 170 of the free lift cylinders 160 and 162 are extended, the pulleys 171 and 173 move upward and the forward ends of the chains 175 and 177 are raised a corresponding amount to slide the fork carriage 124 upward on the inner telescopic section 130.

[0027] As shown in Fig. 9, the fork carriage 124 requires hydraulic hoses 179 to operate an extend and retract mechanism mounted therein. These hoses 179 extend over a hose pulley 181 which is mounted above the chain pulley 171 on the left free lift cylinder 160. One end of each hose 179 is anchored on the rear side of the free lift cylinders 160 and the other end connects to the hydraulic circuit in the fork carriage 124.

[0028] As shown best in Figs. 4A and 4B, the telescopic mast structure is raised and lowered by a pair of main lift cylinders 172 and 174. The lower ends of the cylinders 172 and 174 are fastened to the base section 126 adjacent each end of base cross-tie 136. Rods 176 and 178 extend upward from respective main lift cylinders 172 and 174 and fasten to the upper cross-tie 150 on outer telescopic section 128. When the lift cylinders 172 and 174 are hydraulically operated in response to commands from the operator, the outer telescopic section 128 is lifted and lowered with respect to the base section 126 to extend and retract the mast.

[0029] As shown best in Fig. 5B, the telescopic motion of the outer telescopic section 128 in response to operation of the main lift cylinders 172 and 174 also operates the inner telescopic section 130 through a pair of lift chains 180 and 182. The lift chains 180 and 182 are supported by pulleys 184 and 186 mounted at the upper ends of respective midlegs 144 and 146 with their axes of rotation oriented in the fore and aft direction. An outboard end 188 of each lift chain 180 and 182 is connected to the inner telescopic section 130, and an inboard end 190 of each lift chain 180 and 182 is connected to the base section 126. When the outer telescopic section 128 is telescoped upward by the main lift cylinders 172 and 174, the pulleys 184 and 186 are lifted upward therewith, and the outboard ends 188 of the lift chains 180 and 182 also lift, or telescope upward to lift the inner telescopic section 130. Thus, the inner and outer telescopic sections 130 and 128 slide in unison when the main lift cylinders 172 and 174 are operated to extend or retract the mast.

[0030] Referring particularly to Fig. 6, the shape and location of the above mast assembly elements are designed to maximize the operator's field of view when looking forward through the mast. Looking at the left mast column, the C-shaped baseleg 134

formed by a web and forward and rear flanges substantially encloses the J-shaped midleg 146 which nests therein. The J-shaped midleg 146 has a web with a forward flange formed along the leading edge of the web and a much smaller rear flange formed along, and extending in one direction only from, the trailing edges of the web. The I-shaped top leg 154 formed by a web and forward and rear flanges is immediately inboard the baseleg 134 with their respective rear flanges 200 and 202 substantially aligned. The lift chain pulley 186 is mounted in the web 204 of the midleg 146 and it is disposed forward of the top leg 154. The resulting assembly of mast elements is compact in the lateral direction without lengthening the truck in the fore/aft direction. The right side of the mast is a mirror image of the left side, although other elements now to be described are not necessarily symmetrically arranged. In addition to the compact arrangement of elements, the left and right mast columns provide protection for the lift chains 180 and 182.

[0031] Referring still to Fig. 6, other elements of the mast are also arranged to maximize the operator's field of view. The main lift cylinders 172 and 174 are positioned directly behind the respective baselegs 134 and 132. By using two main lift cylinders 172 and 174 rather than one, their diameters may be reduced such that they do not significantly increase truck length when moved behind the mast. The right side free lift cylinder 162 is positioned directly behind the top leg 152 so as not to increase the lateral dimension of the right mast column. On the other hand, the left side free lift cylinder 160 is positioned behind and inboard the rear flange 202 of the top leg 154. This arrangement allows the free lift cylinder 160 to be moved forward approximately .25 inches so that the much larger hose pulley 181 that supports the hoses 179 can be moved forward into the viewing "shadow" of the left mast column.

[0032] Another asymmetry between the left mast column and right mast column is a set of hose pulleys 205 disposed behind the left mast column, between the main lift cylinder 172 and the free lift cylinder 160. As shown in Fig. 5B, these pulleys 205 are mounted to a support bracket 207 that extends downward from the upper crossie 150 on outer telescopic section 128. The hoses which these pulleys 205 support hang down at eye level regardless of mast height and their location in the viewing shadow of the left mast column is a significant contribution to the operator's increased field of view. As will be explained below, this asymmetric arrangement of the left and right mast columns provides

a maximum field of view for an operator who is positioned to the right of the central fore and aft axis 208 of the lift truck.

[0033] Referring particularly to Fig. 7, an operator positioned in the operator's compartment can assume a number of different positions which provide different fields of view when looking forward through the mast. When the operator takes a centered forward stance his field of view emanates from point 206 which is located near the fore and aft central axis 208 of the lift truck. Two regions 210 and 212 are blocked from view by the left and right mast columns when the operator is in this position.

[0034] The operator can also take a right forward, or side stance position, in which his field of view emanates from a point 214 far to the right of the central axis 208. Two regions 216 and 218 are blocked from view by the left and right mast columns when the operator is in this position. It should be apparent that by shifting between these two operator positions the forward field of view extends to all but two, small triangular areas 220 and 222. Most importantly, the forks 224 are in complete view as are the ends of both baselegs 118.

THE CLAIMS DEFINING THE INVENTION ARE AS FOLLOWS:

1. A mast for a lift truck which comprises:

a base section of having a pair of spaced, upright baseleg members attached to the lift truck;

an outer telescopic section having a pair of spaced, upright midleg members slidably attached to the pair of baseleg members and disposed laterally inward therefrom;

an inner telescopic section having a pair of spaced, upright top leg members slidably attached to the pair of midleg members and disposed laterally inward therefrom;

a pair of lift chain pulleys, one mounted to the upper end of each midleg member and each being disposed forward of the top leg members of the inner telescopic section;

a pair of lift chains, one disposed over each of the lift chain pulleys and having one end connected to the baseleg member and a second end connected to the top leg member; and

a pair of main lift cylinders connected between the base section and the outer telescopic section and being operable to extend the mast upward by sliding the outer telescopic section with respect to the base section.

2. The mast as recited in claim 1 in which each main lift cylinder is disposed to the rear of one of said respective baseleg members.

3. The mast as recited in claim 1 which includes:

a carriage slidably mounted to the inner telescopic section; and

a pair of free lift cylinders mounted to the inner telescopic section and being operable to slide the carriage up and down the inner telescopic section, said free lift cylinders being disposed to the rear of the inner telescopic section.

4. The mast as recited in claim 3 in which one of said free lift cylinders is connected to one of said top leg members and substantially laterally aligned therewith, and the other free lift cylinder is connected to the other top leg member and laterally aligned inboard said other top leg member.

5. The mast as recited in claim 4 in which the free lift cylinders each include a rod having a chain pulley mounted to its end, and a pair of free lift chains extend over the respective chain pulleys and connect to the carriage.

6. The mast as recited in claim 5 in which a hose pulley is mounted to the end of the rod associated with said other free lift cylinder, and hoses extend over the hose pulley and connect to the carriage.

7. The mast as recited in claim 4 in which a hose pulley is mounted to the upper end of the outer telescopic section, the hose pulley being aligned laterally between one of said main lift cylinders and the other of said free lift cylinders and being disposed to the rear of the midleg member of said outer telescopic section.

8. The mast as recited in claim 1 in which the baseleg members each have a c-shaped cross section formed by a web and forward and rear flanges; the midleg members each have a J-shaped cross section which is disposed laterally inboard the baseleg member web and between the baseleg member flanges; and the top leg members each have an I-shaped cross section formed by a web and forward and rear flanges, the top leg members each being disposed laterally inboard from both the baseleg members and the midleg member with their rear flanges substantially aligned with the rear flanges of the baseleg members.

9. The mast as recited in claim 8 in which each lift chain pulley extends through the web portion of the midleg member to which it mounts.

10. The mast as recited in claim 1 in which each midleg member has a web portion and a forward flange; the top leg member has a web and a forward flange; and the lift chain pulleys are rotatably mounted in openings in the web portion of each respective midleg member with their axes of rotation in the fore and aft direction, and wherein the lift chain pulleys are positioned between the forward flanges of the midleg member and the top leg member.

11. A mast column for a lift truck which comprises:

a baseleg member having a c-shaped cross section formed by a web portion and forward and rear flange portions;

a midleg member slidably mounted to the baseleg member and having a J-shaped cross section with a web portion and a forward flange portion, the midleg member being disposed substantially between the forward and rear baseleg member flanges; and

a top leg member slidably mounted to the midleg member and having an I-shaped cross section formed by a web and forward and rear flange portions, the top leg member being disposed alongside and inward from the midleg member with its rear flange substantially aligned in the fore and aft direction with the rear flange of the baseleg member.

12. The mast column as recited in claim 11 in which a lift chain pulley is rotatably mounted to the midleg member and positioned forward of the forward flange on the top leg member.

13. The mast column as recited in claim 12 in which the lift chain pulley extends through an opening in the midleg member web portion with its axis of rotation oriented in the fore and aft direction, and the lift chain pulley is disposed between the forward flanges of the midleg member and the top leg member.

14. A mast for a lift truck substantially as herein described in any one of the embodiments in the detailed description of the invention with reference to the drawings.

15. A mast column for a lift truck substantially as herein described in any one of the embodiments in the detailed description of the invention with reference to the drawings.

DATED THIS FIFTH DAY OF AUGUST 2004

The Raymond Corporation

By

PIZZEYS PATENT AND TRADE MARK ATTORNEYS

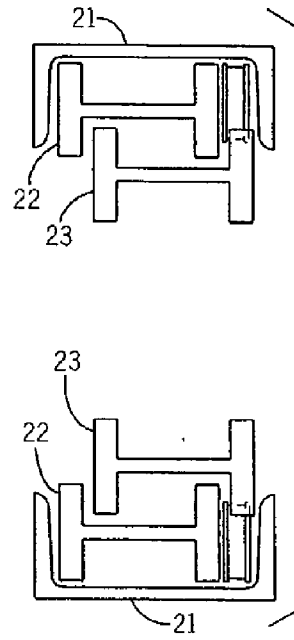
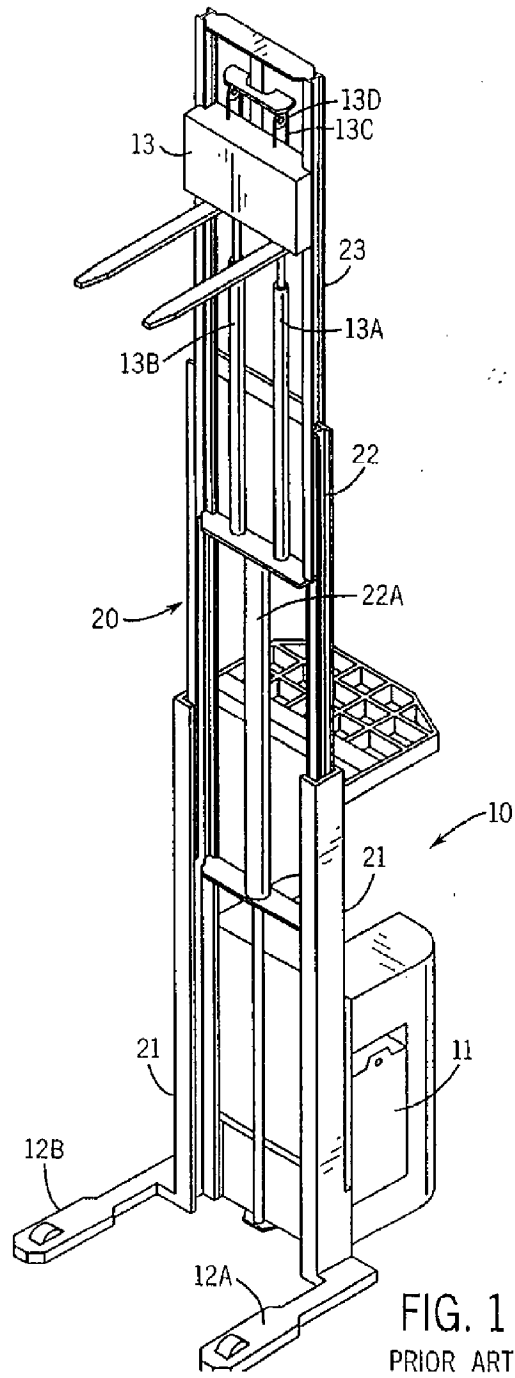

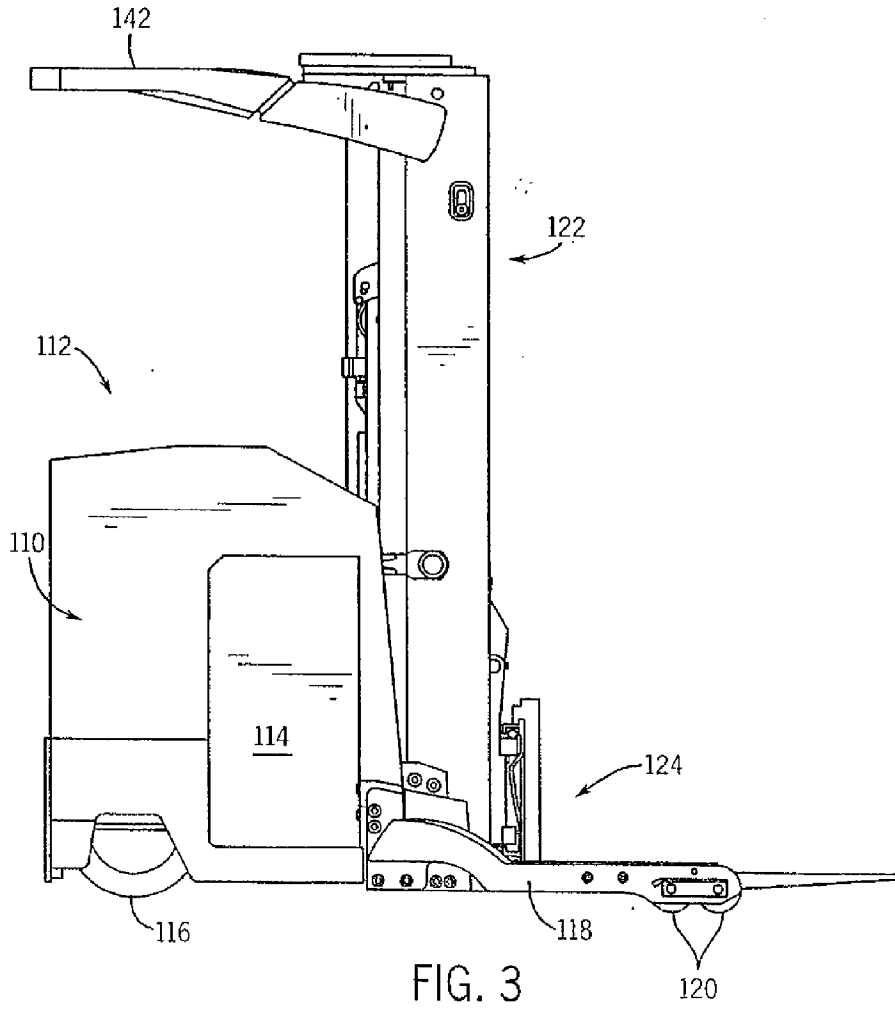

FIG. 3

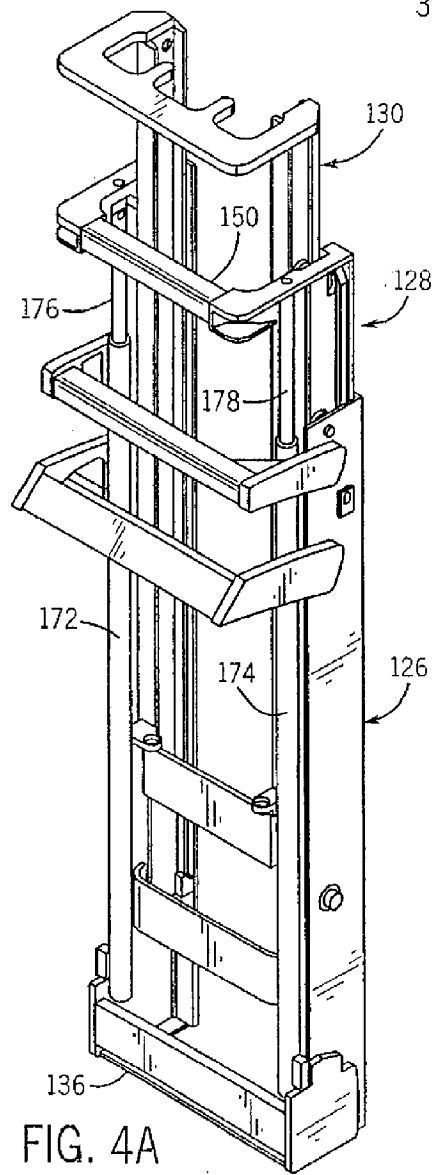

FIG. 4A

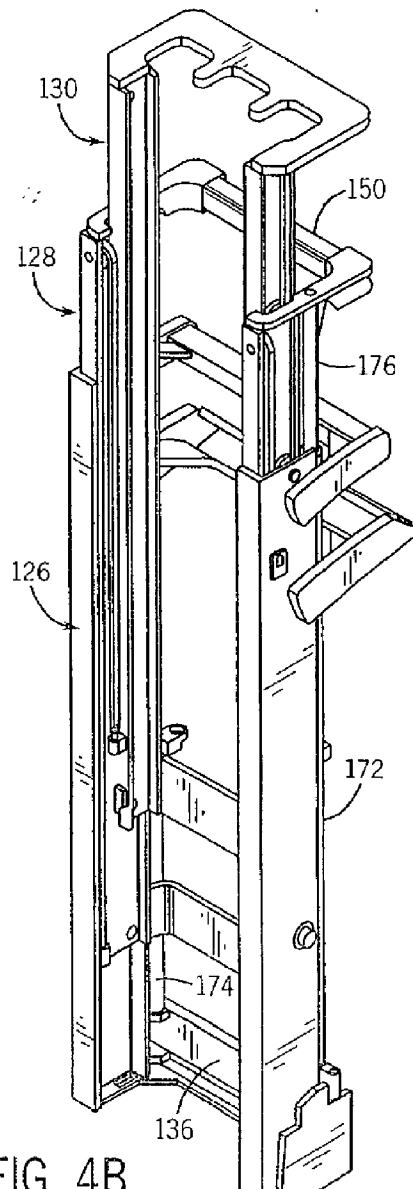
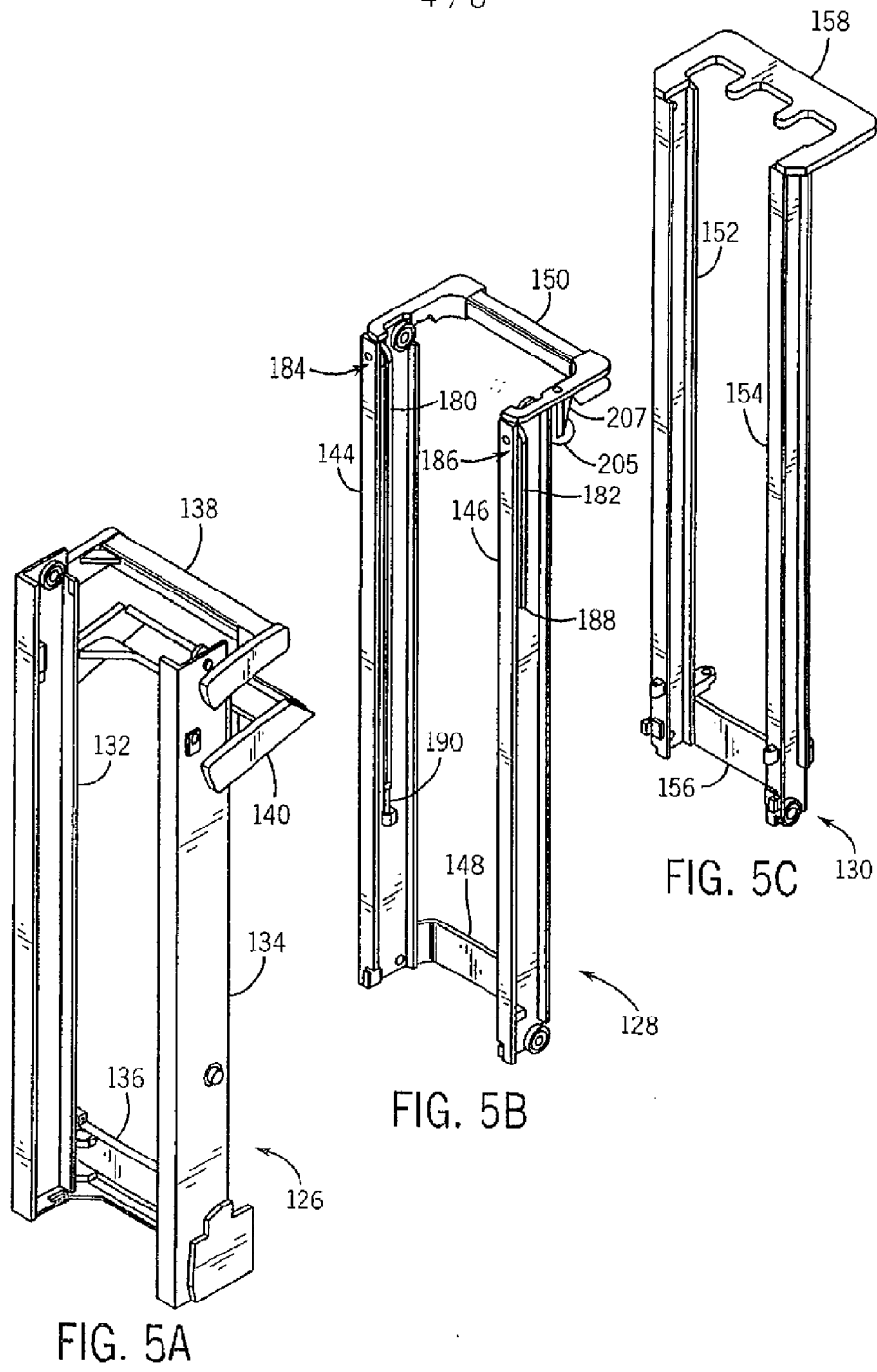

FIG. 4B



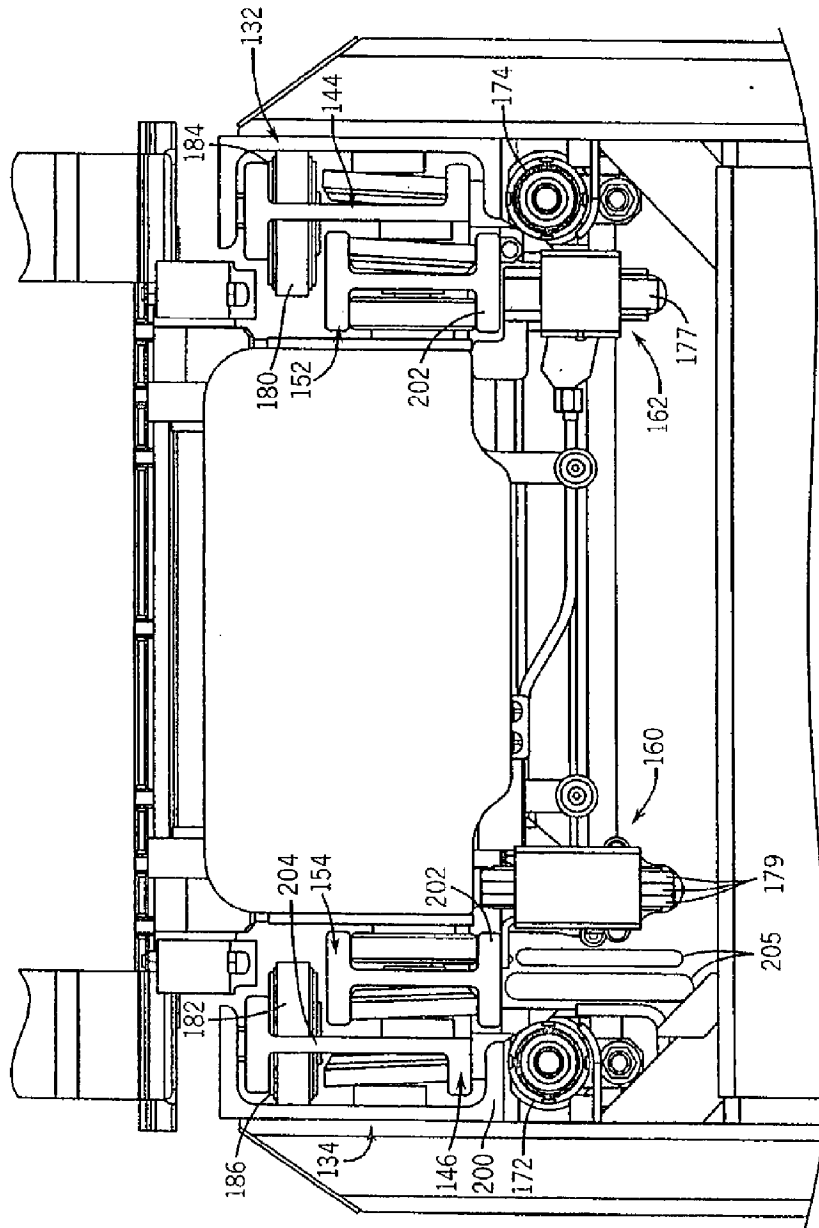

FIG. 6

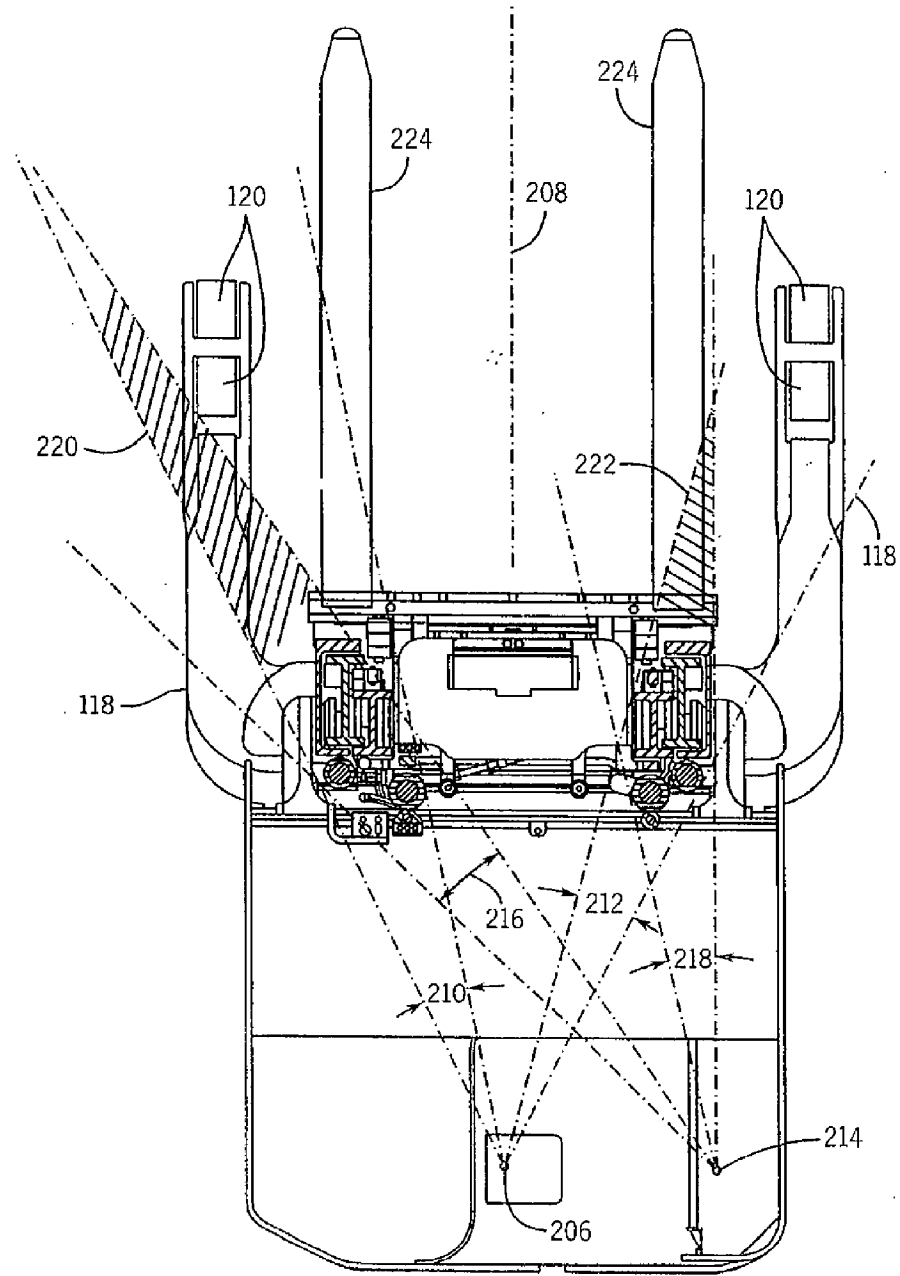

FIG 7

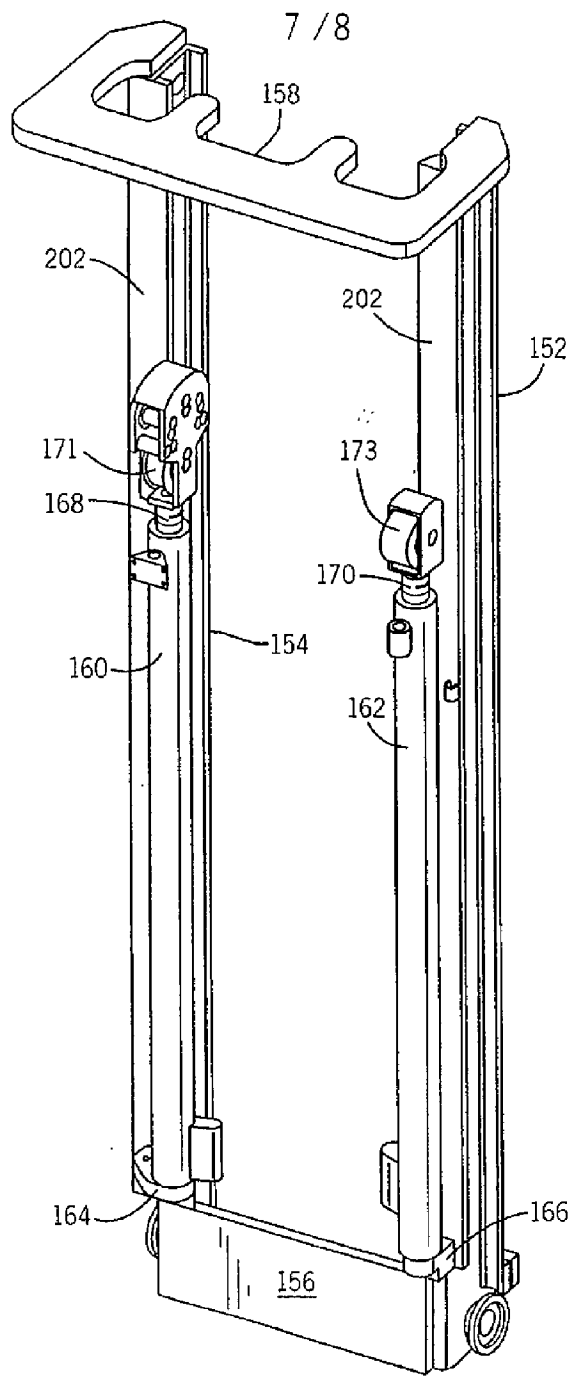

FIG 8

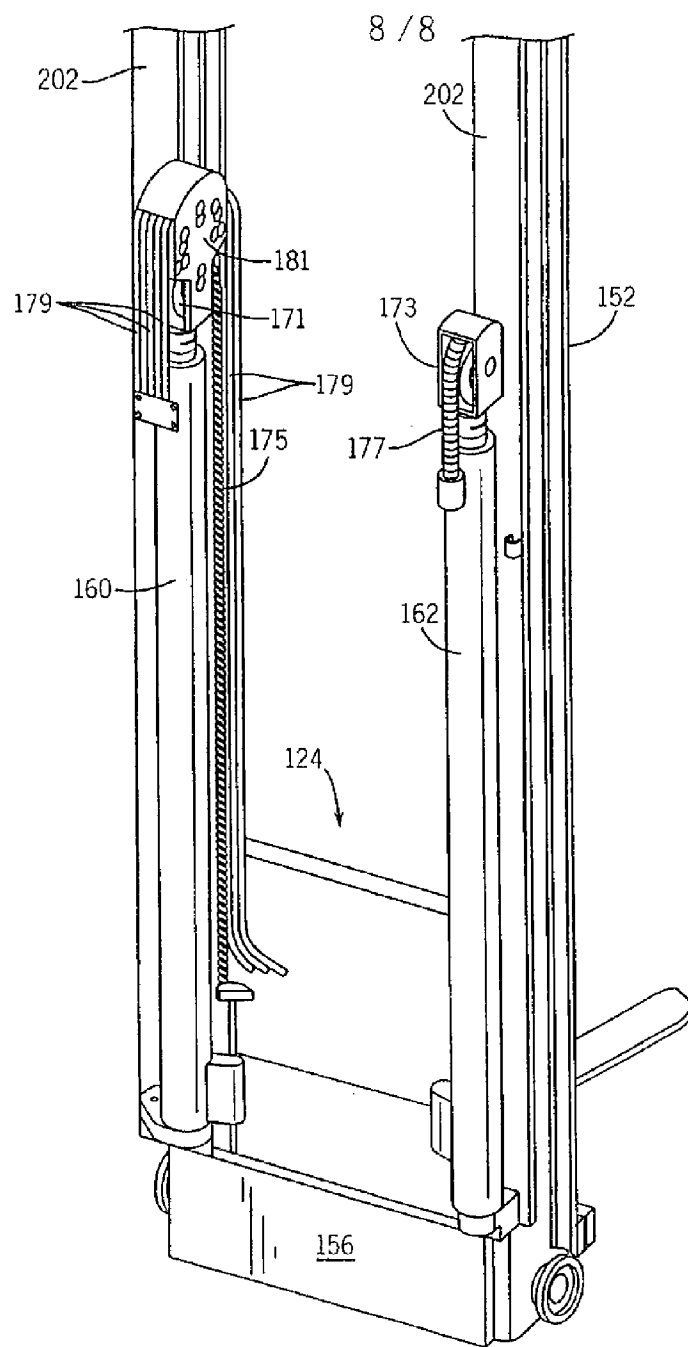

FIG 9