

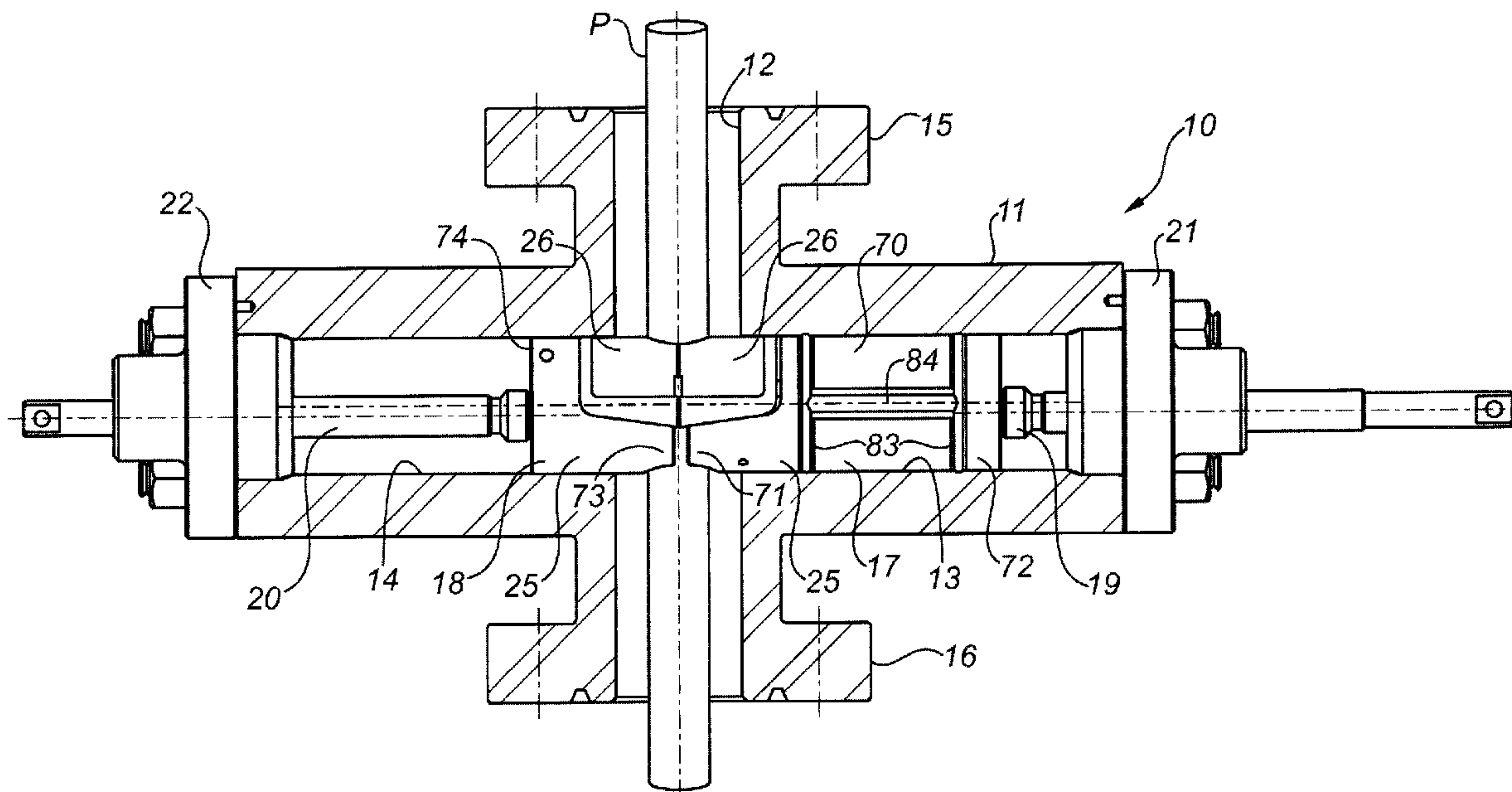

(22) Date de dépôt/Filing Date: 2007/01/26  
(41) Mise à la disp. pub./Open to Public Insp.: 2007/07/27  
(45) Date de délivrance/Issue Date: 2013/11/12  
(30) Priorité/Priority: 2006/01/27 (US60/762,638)

(51) Cl.Int./Int.Cl. *E21B 33/06* (2006.01)  
(72) Inventeur/Inventor:  
LAM, TONY M., CA  
(73) Propriétaire/Owner:  
STREAM-FLO INDUSTRIES LTD., CA  
(74) Agent: MCKAY-CAREY & COMPANY

(54) Titre : BLOC OBTURATEUR DE TETE DE PUITS COMPORTANT UNE MACHOIRE ALLONGEE POUR OBTURER UN PUITS DE FORAGE CENTRAL  
(54) Title: WELLHEAD BLOWOUT PREVENTER WITH EXTENDED RAM FOR SEALING CENTRAL BORE



(57) **Abrégé/Abstract:**

A blowout preventer (BOP) is provided in which one of the BOP rams is formed with an extended central bore sealing section to seal across the central bore in a central bore closing position when the polish rod is not present. The ram bores of the BOP are sized to accommodate this extended central bore sealing section in any of the open, sealing or central bore closing positions. The front ends of the BOP rams may be adapted to carry elastomeric or thermoplastic seals to seal against the polish rod or against each other. The central bore seals for the extended central bore sealing section may be formed with elastomeric or thermoplastic seals. In the case of thermoplastic seals, the rams and ram bores are adapted to ensure that the thermoplastic seals are compressed outwardly, to seal the ram bores, or are lifted upwardly, to seal the central bore.

**ABSTRACT**

1

2           A blowout preventer (BOP) is provided in which one of the BOP rams is formed  
3 with an extended central bore sealing section to seal across the central bore in a central  
4 bore closing position when the polish rod is not present. The ram bores of the BOP are  
5 sized to accommodate this extended central bore sealing section in any of the open,  
6 sealing or central bore closing positions. The front ends of the BOP rams may be  
7 adapted to carry elastomeric or thermoplastic seals to seal against the polish rod or  
8 against each other. The central bore seals for the extended central bore sealing  
9 section may be formed with elastomeric or thermoplastic seals. In the case of  
10 thermoplastic seals, the rams and ram bores are adapted to ensure that the  
11 thermoplastic seals are compressed outwardly, to seal the ram bores, or are lifted  
12 upwardly, to seal the central bore.

1                   **WELLHEAD BLOWOUT PREVENTER WITH EXTENDED RAM**  
2                   **FOR SEALING CENTRAL BORE**

3                   **FIELD OF INVENTION**

4                   The invention relates to a wellhead blowout preventer (BOP), and more  
5 particularly to a production BOP capable of sealing against a polish rod when in place,  
6 and against the central bore when the polish rod is not present.

7  
8                   **BACKGROUND OF INVENTION**

9                   The rams of a BOP may operate in different ways in closing off a well, or multiple  
10 BOPs may be used in a wellhead stack to provide different functions. In a production  
11 well, polish rod rams seal around a polish rod extending through the wellhead. Blind  
12 rams seal against each other across the central bore when no polish rod is in place.

13                  A typical prior art BOP for a production wellhead is disclosed in U.S. Pat. No.  
14 5,765,813 to Lam et al., issued Jun. 16, 1998, owned by Stream-Flo Industries Ltd., the  
15 assignee of this patent application. This type of BOP is commonly used in connection  
16 with pumping wells. With such wells, a sucker rod string is reciprocated or rotated to  
17 drive a downhole pump, which lifts the produced fluid to surface through a tubing string.  
18 The BOP is equipped with polish rod rams which can be advanced horizontally to seal  
19 around the vertical polish rod of the rod string, to prevent the upward escape of fluid.  
20 Alternatively, if the rod string is out of the well, the inner or front ends of the rams can  
21 be pressed together to cause closure of the wellhead assembly fluid passageway.  
22 Alternatively, the front ends of the rams can be configured as blind rams such that they  
23 seal against each other across the central bore when the polish rod is not in place.

24                  More particularly, the prior art BOP includes a cross-shaped housing forming a  
25 central vertical bore and a pair of coaxial, horizontal ram bores intersecting the central  
26 bore from each side. The BOP is commonly positioned in the wellhead assembly

1 between the tubing head and flow tee. In such an embodiment, the BOP central bore  
2 forms part of the wellhead assembly fluid passageway. Within the BOP, a pair of rams  
3 is positioned in the horizontal ram bores. Means, such as screw jacks or actuators  
4 (mechanical, electrical, pneumatic or hydraulic), are provided at the outer ends of the  
5 ram bores, for advancing or retracting the rams into or out of the central bore, in order  
6 to close or open the central well bore.

7 Each ram comprises a generally cylindrical body, although other shaped ram  
8 bodies are known (ex. oval or square in cross section). The ram body generally  
9 comprises a steel core, preferably having an outer full bore diameter portion and a  
10 reduced diameter inner portion. The ram core inner portion is covered with and bonded  
11 to a layer of an elastomeric material, typically a nitrile rubber.

12 The ram bores, typically cylindrical, extend into the central bore and the bore  
13 surfaces combine at their intersection to form sealing areas. When the rams move into  
14 the central bore, the rubber surfaces of their inner portions seal against the sealing  
15 surfaces.

16 The rubber-coated inner or front face of each ram is formed to provide a  
17 semi-circular, vertically directed groove. Thus, when the polish rod of the rod string is  
18 present in the central bore, the ram ends encircle and press against it, to form a seal of  
19 the central bore. When the polish rod is not in the central bore, the ram ends compress  
20 together to form a solid block. In both cases, the circumferential seals of the ram side  
21 surfaces, with the sealing areas and the end face seals, combine to close the central  
22 bore and contain pressurized fluids.

23 One major problem associated with production BOP's is that the pressure acting  
24 from below on the closed rams may extrude the side rubber upwardly so that the  
25 circumferential seal with the sealing areas is lost. Another problem is that the end  
26 rubber bonded to the vertical end faces of the ram cores may tear loose from the core

1 when high pressure is exerted from below. In severe conditions, such as injecting  
2 chemicals to close off a well, the rubber degrades quickly, causing the seals to fail.

3 As described in U.S. Patent No. 5,765,813, the side surface of each ram core  
4 inner portion is formed to provide ribs extending outwardly therefrom and extending  
5 longitudinally thereof. The ribs are located so as to underlie those portions of the  
6 elastomer layer which seal against the sealing areas. The elastomer layer is thinned  
7 where it passes over the ribs, to preserve the cylindrical shape of the ram's inner  
8 portion. The ribs function to reinforce the elastomer layer against upward extrusion.  
9 Comparative pressure tests have shown that a ribbed ram is able to contain several  
10 times the pressure that a non-ribbed ram could contain, before the seal was lost.

11 In accordance with a preferred feature of U.S. Patent No. 5,765,813, the vertical  
12 end face of the core inner portion is indented, for example with a plurality of spaced  
13 apart transverse grooves or dimples or a single cavity, so that the base of the elastomer  
14 layer projects into these indentations. As a result, increased face surface area is  
15 provided to bond with the elastomer. In addition, the elastomer external of the  
16 indentations must shear from the elastomer in the indentations, before failure occurs  
17 and the elastomer separates from the steel. In this way, the resistance to failure of the  
18 elastomer/steel bond at the ram end faces is improved. The device of U.S. Patent No.  
19 5,765,813 improves the ability of the BOP ram to seal against the high pressure from  
20 below without losing the side seal, and better prevent against the rubber being torn  
21 loose from the ram.

22 Canadian Patent Application No. 2,260,655, published Aug. 2, 2000, and owned  
23 by Stream-Flo Industries Ltd., describes a ram type BOP for high temperature  
24 applications. The BOP incorporates a generally L-shaped seal element formed of a  
25 graphite or asbestos seal material, which is sandwiched between a bottom L-shaped  
26 steel retainer plate and a semi-cylindrically shaped steel top retainer plate. This design  
27 of BOP ram is well suited for brittle seal materials such as graphite and asbestos, which

1 are used when steaming of the well may occur.

2 The BOP devices of the above patents do not adequately address all  
3 applications involving harsh chemical conditions. Rubber-type seal materials  
4 (elastomeric seals) are subject to being degraded by the harsh conditions of some  
5 wellheads, for example where chemicals are injected. For instance, in wells in which  
6 heavy wax deposits accumulate in the annulus, outlet lines, and anywhere that the  
7 production fluid flows, a chemical inhibitor is introduced into the production fluid as a  
8 means to break down the deposits. While the inhibitor is effective in clearing the lines,  
9 it has the major disadvantage of acting as a dissolving agent on the O-ring seals,  
10 rubber ram inserts and any elastomeric materials found inside the wells, causing these  
11 seals to fail prematurely.

12 Thermoplastic materials having superior chemical resistance are available, but  
13 have different compressibility and elastic properties than elastomeric sealing materials  
14 such as nitrile rubbers. Thus, the prior art BOP devices are not generally amenable to  
15 simple substitution of thermoplastics for the rubber sealing components.

16 In U.S. Patent No. 7,137,610, issued November 22, 2006, naming inventor Tony  
17 M. Lam, and owned by Stream-Flo Industries Inc., there is described a production BOP,  
18 and BOP rams, which incorporate thermoplastic seals at the front of the rams to seal  
19 against the polish rod.

20 There is a need for a production BOP which can reliably seal against a polish  
21 rod, but which can also seal the central bore when the polish rod is not in place. This  
22 could also eliminate the need for multiple valves and BOPs in a wellhead stack.

## 23 **SUMMARY OF INVENTION**

24 The invention provides, in one broad aspect, a production blowout preventer,

1 comprising:

2 a housing forming a central bore, which extends vertically through the housing,  
3 and a first and a second horizontal ram bore extending radially outwardly in opposite  
4 directions through the housing and intersecting the central bore, with sealing surfaces  
5 being formed across the wall surfaces at the intersection of the ram and central bores;

6 a first ram positioned in the first ram bore for sliding movement therealong;

7 a second ram positioned in the second ram bore for sliding movement

8 therealong;

9 the first and second rams each including a ram body having front and rear ends,  
10 each of the ram bodies being slidable along the ram bores so as to project into the  
11 central bore where their front ends are adapted to seal against a polish rod of a rod  
12 string extending therethrough, and each of the ram bodies optionally carrying one or  
13 more seals for sealing against the ram bore in which it is positioned;

14 the first ram body including an extended central bore sealing section between its  
15 front and rear ends, said central bore sealing section carrying one or more central bore  
16 seals for sealing across the central bore when the extended central bore sealing section  
17 is positioned across the central bore in a central bore closing position;

18 the first ram bore being of sufficient length to accommodate the first ram body in  
19 a fully extended or fully retracted position;

20 the second ram bore being of sufficient length to accommodate the second ram  
21 body in a fully extended or fully retracted position, and to also accommodate the front  
22 end of the first ram when in the central bore closing position; and

23 means connected to the rear of each ram body for advancing and withdrawing  
24 the first and second rams between open, sealing and central bore closing positions.

25 The front ends of each of the first and second rams is adapted to seal against  
26 the polish rod, or in the case of a blind ram, against each other, as is well known in the  
27 art, including, for example, any of the front end BOP ram seals shown in the patents  
28 mentioned herein, and as shown hereinbelow. Thermoplastic or elastomeric seals may  
29 be used at the front ends of the first and second rams to seal against the polish rod, or

1 against each other.

2 The central bore seals of the first ram may take multiple designs and may be  
3 made of thermoplastic or elastomeric type materials.

4 The invention extends to wellhead assemblies including the BOP of this  
5 invention alone, or together in an integral composite assembly with one or more other  
6 components which might include, in any sequence, adaptors, control valves, additional  
7 BOP rams, check valves, flow tee, and polish rod clamp. The wellhead assembly of  
8 this invention includes top and bottom connectors for connecting to wellhead  
9 components located above and below. Such connectors may be of any type, as is  
10 known in the industry, including for example studded connectors, flange connections,  
11 welded connections, clamp and threaded connections. Importantly, the BOP of this  
12 invention, incorporating the extended first ram with central bore sealing capability, may  
13 allow one or more of the extra BOP or shut-off valves in the wellhead or the composite  
14 wellhead assembly, to be omitted.

15 The rams and ram bores may be of any shape or configuration as is known for in  
16 the BOP art. While the figures show the rams and ram bores as being cylindrical in  
17 cross-section, they may be alternatively shaped, such as oval or rectangular in cross  
18 section. As used herein, the term "cylindrical" is understood to include rams and ram  
19 bores which are generally circular or oval in cross section.

20 It should be understood that the terms "inner", "outer", "front", "rear", "back",  
21 "upper", "lower", "top" and "bottom", as used herein and in the claims with reference to  
22 the wellhead components and the BOP ram or its parts, refer to the component or ram  
23 as it is designed to be positioned in one of the horizontal bores, for movement forwardly  
24 into the central bore or rearwardly in the horizontal ram bores. By "inner" or "front", as  
25 used herein, is meant the portion or end of the ram or its parts at the central bore. By  
26 "rear" or "back" is meant the portion or end of the ram or its parts opposite the front. By

1 “outer” is meant the outer circumferential portion of the ram or its parts. An “outwardly”  
2 motion is meant to refer to an outward movement (including a rearward and upward  
3 motion) of the thermoplastic sealing surface against the horizontal cylindrical bore, so  
4 as to seal against the horizontal bore. The term “central” in reference to the “central  
5 bore” is not meant to exclude a generally vertical bore which may be somewhat off-  
6 centre in the wellhead assembly in which it is included.

7 “Elastomeric” materials include rubber type seal materials such as nitrile rubber  
8 seals. “Thermoplastic” materials include polytetrafluoroethylene (PTFE), ex. Teflon®,  
9 but preferably modified with fillers such as carbongraphite or glass, which strengthen  
10 the polymers. For environments which expose seals to chemicals, the strengthened  
11 thermoplastic polymers are most preferred.

12

13 As used herein and in the claims, a reference to “a connection,” “connected” or  
14 “connect(s)” is a reference to a sealed pressure-containing connection unless the  
15 context otherwise requires.

16 As used herein and in the claims, “comprising” is synonymous with “including,”  
17 “containing,” or “characterized by,” and is inclusive or open-ended and does not  
18 exclude additional, unrecited elements.

19 The use of the indefinite article “a” in the claims before an element means that  
20 one or more of the elements is specified, but does not specifically exclude others of the  
21 elements being present, unless the contrary clearly requires that there be one and only  
22 one of the elements.

23

### **BRIEF DESCRIPTION OF THE DRAWINGS**

24 Figure 1 is a side sectional view of a production blowout preventer (BOP) of this  
25 invention with both of the first and second rams in a sealing position against the polish

1 rod, but showing the first ram (on the right) including an extended central bore sealing  
2 section.

3 Figure 2 is a side sectional view of the BOP of Figure 1, but showing the first ram  
4 (on the right) in the central bore closing position to seal the central bore.

5 Figure 3 is a side sectional view of a BOP of Figure 1, shown with both BOP  
6 rams retracted (open), and in which the rams are hydraulically actuated.

7 Figure 4 is a side perspective view of the first ram of Figure 1, showing the front  
8 end adapted for sealing with a thermoplastic seal against the polish rod in the manner  
9 disclosed in U.S. Patent 7,137,610, and having an extended central bore sealing  
10 section between its front and rear ends for sealing across the central bore when in the  
11 central bore closing position. The central bore seals include a pair of circumferential  
12 ring seals and side rib seals.

13 Figure 5 is a side view of the first ram of Figure 4, but showing in dotted outline  
14 connectors for the front thermoplastic seal component, and a T-slot for connecting to  
15 the ram screws.

16 Figures 6A and 6B provide two views, front (6A) and rear (6B) perspectives, of  
17 an alternate first ram of the present invention, in which the extended central bore  
18 sealing section includes a central bore seal which is a saddle shaped circumferential  
19 seal sized to seal the central bore when in the central bore closing position.

20 Figure 7 is a side sectional view of an alternate BOP of this invention, shown  
21 with both BOP rams retracted (open), and in which the first and second rams are  
22 hydraulically actuated. The front ends of the rams carry elastomeric seals adapted to  
23 seal against the polish rod in a manner similar to that shown in U.S. Pat. No. 5,765,813.  
24 The seals to the central bore are as shown in Figure 4.

1           Figure 8 is a side perspective view of the first ram of Figure 7.

2           Figure 9 is a side perspective view of a first ram which differs from that in Figure  
3 8 in that only two circumferential ring seals are provided.

4           Figure 10 is a side sectional view of an alternate BOP of this invention, shown  
5 with both BOP rams retracted (open), wherein the first and second rams are adapted at  
6 their front ends to seal against the polish rod with an molded elastomeric material or a  
7 block of thermoplastic material such as urethane or Teflon®.

8           Figure 11 is a side perspective view of the first ram of Figure 10.

9           Figure 12 is a side view, partially in section, of a wellhead assembly of this  
10 invention having as components of an integral composite pumping tree, from the  
11 bottom to the top, a master gate valve, a central bore closing BOP of this invention as  
12 shown in Figure 1, a BOP as disclosed in U.S. Patent 7,137,610, and the profile for a  
13 flow tee (sequence of components may vary).

14           Figure 13 is a side sectional view of an alternate BOP of this invention, shown in  
15 the central bore closing position without the polish rod, and in which the rams differ  
16 from those shown in Figure 1 in that the saddle shaped central bore seal in the  
17 extended central bore sealing section is a thermoplastic seal.

18           Figure 14 is an end view of the first ram of Figure 13, taken along line 14 - 14,  
19 partially in section to show one of the feet and one of the stepped channels used to lift  
20 the thermoplastic saddle seal into a sealing position in the central bore.

21           Figure 15 is a side sectional view of the BOP of Figure 13, with the rams  
22 removed to show extra lines along the ram bores to illustrate the progressive steps in  
23 the channels along the ram bores.

1 Figure 16 is a side view of the first ram of Figure 13, showing the spaced feet.

2 Figure 17 is a side sectional view of an alternate embodiment of the invention  
3 wherein the first ram includes spring biased parts as lifting means at the extended  
4 central bore sealing section to upwardly seal against the central bore.

5 Figure 18 is a side sectional view of a further alternate embodiment of the  
6 invention wherein the first ram is adapted to provide thermoplastic seals at both its front  
7 end and in the central bore sealing section by extending the front body component and  
8 the seal component to the rear end of the first ram, such that, when in central bore  
9 sealing position, the front end of the seal component contacts the second ram causing  
10 the seal component to be pressed against the seal support surface of the body  
11 component such that the thermoplastic sealing surface is compressed outwardly to seal  
12 against the central bore and to seal the central bore.

### 13 DESCRIPTION OF PREFERRED EMBODIMENTS

14 Multiple preferred embodiments of the production blowout preventer (BOP) of  
15 the present invention, or a composite wellhead assembly containing the BOP, are  
16 shown in the Figures, with like parts being labeled with the same reference numerals.

17 Having reference to Figure 1, a production blowout preventer (BOP) is shown  
18 generally at 10, to include a cross-shaped steel housing 11 forming a central bore 12,  
19 extending vertically through the housing 11, and a pair of co-axial horizontal first and  
20 second ram bores 13, 14. The ram bores 13, 14 are slightly larger in diameter than the  
21 central bore 12, as is common in BOP devices. Top and bottom flange connections 15,  
22 16 to wellhead components located above and below the BOP 10 are shown, although  
23 alternate connections such as threaded, welded, studded, or clamp connections might  
24 be used. The horizontal ram bores 13, 14 intersect with the central bore 12. The polish  
25 rod P is shown in place in the central bore 12.

1           Generally cylindrical first and second rams 17, 18 of the BOP 10 are shown in  
2 the Figures to be (when assembled, if in multiple parts) generally cylindrically shaped in  
3 order to seal in the ram bores 13, 14. The rams 17, 18 are locked onto the ends of ram  
4 screws 19, 20, which extend through end plugs 21, 22 at the outer ends of the ram  
5 bores 13, 14. The ram screws 19, 20 can be turned to advance or retract the rams 17,  
6 18 into or out of the central bore 12 with mechanical screw jacks (not shown), or as  
7 shown in Figures 3 and 7, the ram screws 19, 20 can be advanced and retracted with  
8 hydraulic actuators 23, 24. It should be understood that the rams 17, 18 may be  
9 alternately actuated, for instance by pneumatic or electrical actuators. Actuators may  
10 be single or double acting, as known in the art. Any of these mechanical screw jacks or  
11 alternate actuators thus illustrate means for advancing and withdrawing the first and  
12 second rams 17, 18 between their open, sealing and central bore closing positions  
13 within the patent claims.

14           It should be understood that the ram bores 13, 14 and corresponding rams 17,  
15 18 are not necessarily strictly cylindrical in shape. The rams and bores may take  
16 alternate shapes, such as oval in cross section, or even rectangular in cross section, as  
17 is known in the art, without departing from the present invention.

18           The first ram 17 (the extended ram shown on the right in the Figures) is shown to  
19 be longer or extended, relative to the needed length of the second ram 18, including an  
20 extended central bore sealing section 70 between its front and rear ends 71, 72. The  
21 second ram 18 also includes a front and rear end 73, 74. The ram bores 13, 14 are of  
22 sufficient length to accommodate the first and second rams 17, 18 in their fully retracted  
23 or fully extended positions. The rams 17, 18 are shown in Figure 1 in their extended,  
24 sealing position, with front ends 71, 73 sealed against the polish rod P. In Figure 2, the  
25 rams 17, 18 are shown in the central bore closing position, with the second ram 18 fully  
26 retracted, the first ram 17 fully extended, and the central bore sealing section 70 being  
27 positioned in a sealing mode across the central bore 12. The second ram bore 14 is  
28 thus of a length sufficient to include, not only the second ram 18, but also the front end

1 71 of the first ram 17, in this fully extended position. Figure 3 shows the rams 17, 18 in  
2 their open, fully retracted positions, wherein fluid flow is permitted in the central bore  
3 12.

4 The front ends 71, 73 of the rams 17, 18 are each adapted to provide front face  
5 seals which seal against the polish rod P. Any front end sealing configuration for these  
6 BOP rams may be provided. Three embodiments of front end sealing configurations  
7 are shown in the Figures. In the embodiments of Figures 1 - 6 and 12 - 18, the front  
8 ends 71, 73 of the rams 17, 18 are configured to carry thermoplastic seals to seal  
9 against the polish rod, as is disclosed in U.S. Patent 7,137,610. In Figures 7 - 9, the  
10 front ends 71, 73 carry elastomeric seals molded in the steel ram body, such as is  
11 disclosed in U.S. Patent 5,765,813. In Figures 10 - 11, the front ends 71, 73 carry a  
12 seal formed from a block of elastomeric or thermoplastic seal, or an elastomeric coating  
13 molded at the fronts of the steel rams 17, 18.

14 The rams 17, 18 will be described in detail with respect to the front ends 71, 73  
15 being configured for providing the thermoplastic seals to the polish rod P (Figures 1 - 6  
16 and 12 - 18). Apart from the extended central bore sealing section 70 included for the  
17 first ram 17, the rams 17, 18 are otherwise identical, so like parts are labeled with  
18 similar numbers in the Figures.

19 Each of the rams 17, 18 is shown to consist of a steel body component 25 and a  
20 seal component 26 (see Figure 4). In an assembled form, the rams 17, 18 are each  
21 generally cylindrical in shape for a tight fitting seal in the appropriate ram bore 13 or 14.  
22 The seal component 26 is shaped to fit into a cut-out 27 at the front of the body  
23 component 25. The cut-out 27 provides a seal support surface 27a to support the seal  
24 component 26 in both a vertical and horizontal direction. The cut-out portion 27 is  
25 preferably generally L-shaped, as shown herein. However, as shown in U.S. Patent  
26 7,137,610, the cut-out portion may have an alternate shape, such as a wedge shape.  
27 The rear end of the body component 25 is formed with a central T-slot 28 (see Figures

1 5, 6) to fit and lock onto the ends of each of the ram screws 19, 20. The body  
2 component 25 is generally formed from a metal such as steel. The seal component 26  
3 is formed to provide a sealing surface of thermoplastic material to seal against the  
4 horizontal ram bore. The seal component 26 is formed either entirely from, or so as to  
5 carry a sealing material such as an insert of, a thermoplastic material. The  
6 thermoplastic material is preferably a polytetrafluoroethylene (PTFE), modified with  
7 carbongraphite or glass fillers, in order to withstand the chemicals used in well  
8 production, but other sealing thermoplastic materials may be used.

9 Each of the body and seal components 25, 26 are formed with a pair of aligned  
10 horizontal pin bores 29, 30 respectively (see Figure 5), to accommodate a pair of  
11 connecting pins 31. One design of the connecting pins 31 is best seen in Figure 5 (see  
12 also U.S. Patent 7,137,610), in which milled out portions (not shown) at the inner ends  
13 of the pins 31 and circumferential grooves 31a allow for locking into place with locking  
14 pins 34 located in vertical bores 35 formed in the seal and body components.

15 Each of the body and seal components 25, 26 is preferably formed with a vertical  
16 radial groove 36 that runs along the front of the assembled ram to accommodate and  
17 seal against the polish rod P. The vertical radial groove 36 may be omitted if the front  
18 ends of the rams 17, 18 are to function as blind rams to seal against each other in the  
19 event that the polish rod is not present. As shown, in its assembled and connected  
20 form with the body component 25, the front of the seal component 26 protrudes beyond  
21 the front of the body component by a distance d (Figure 5).

22 The seal component 26 is generally semi-cylindrical in shape such that, when  
23 connected to the body component 25, the ram is full bore, conforming to the horizontal  
24 ram bores 13, 14. In the embodiment shown, the seal component 26 is shown formed  
25 with a reduced radius portion 37 at its outer circumference, forming a peripheral raised  
26 ridge sealing surface 38 along its outer peripheral (back and bottom) edges. As best  
27 explained below, when the rams 17, 18 are advanced into a closed position against the

1 polish rod P, this peripheral raised ridge sealing surface 38 encircles the central bore 12  
2 and thus functions to seal the central bore 12 when the rams 17, 18 are fully engaged  
3 against the polish rod P.

4 The L-shaped cut-out 27 of the body component 25 is preferably formed with a  
5 slightly inclined (front to rear) acutely angled surface 39. A similarly angled lower  
6 surface 39a is formed on the seal component 26, such that during sealing action, the  
7 seal component 26 rides upwardly and rearwardly on the surface 39 of the body  
8 component 25, as the rams 17, 18 are advanced to close the central bore 12. In its  
9 assembled, connected state, the seal component 26 is seated in the L-shaped cut-out  
10 27, and a gap 40 remains at the rear of the seal component between the components  
11 25, 26. As well, the seal component 26 protrudes horizontally at its front surface  
12 beyond the front end of the body component 25. The horizontal distance d by which  
13 the front surface of the seal component 26 protrudes beyond the body component 25 is  
14 greater than the horizontal width of the gap 40. These relative dimensions relate to the  
15 sealing action of the rams, as described below. Preferably the front sealing face 63 of  
16 each of the seal components 26 includes a cut-away portion 62, preferably in the  
17 central part of the sealing face 63, such that a reduced area of the sealing face 63  
18 forms a better seal to the sealing face 63 of the opposing ram.

19 The nature of the sealing action of the present invention is important to the use  
20 of thermoplastic sealing materials along the peripheral raised ridge sealing surface 38.  
21 The rams 17, 18 seal both against the polish rod P, and outwardly against the  
22 horizontal ram bores 13, 14 to effectively seal the central bore 12 of the BOP housing  
23 11 against high pressure from below. As the rams 17, 18 are initially advanced in the  
24 ram bores 13, 14, the protruding front surfaces 63 of the seal components 26 meet  
25 each other around the polish rod P, causing the seal components 26 to ride upwardly  
26 and rearwardly on the acutely angled surfaces 39 of the body components 25, until the  
27 gaps 40 between the seal and body components 25, 26 are closed, and the seal  
28 components 26 are pressed against the seal support surface 27a. Thereafter, further

1 forward advancement of the rams 17, 18 pushes the seal components 26 forward such  
2 that their protruding front surfaces 63 seal around the polish rod P. As well, the  
3 peripheral raised ridge sealing surfaces 38 of the seal components 26 are pushed  
4 outwardly (upwardly and forwardly on the body component 25) to seal against the walls  
5 of the horizontal ram bores 13, 14.

6 Alternate embodiments of the front end thermoplastic seals for the rams 17, 18  
7 are shown in U.S. Patent 7,137,610, and may be used in the present invention. All  
8 such alternatives fall within the claims of this application.

9 The rams 17, 18 as described above include the seal component 26 above the  
10 body component 25. However, it should be apparent that the rams could be rotated  
11 such that the seal component 26 is on the bottom. Further, the body and seal  
12 components 25, 26 could be modified such that both top and bottom seal components  
13 are carried on a more generally T-shaped body component to form the cylindrical rams  
14 17, 18. Furthermore, the components 25, 26 could be oval shaped rather than strictly  
15 cylindrical. Furthermore, the body component could be two piece if desired. These and  
16 other modifications will be apparent to persons skilled in the art, and are intended to fall  
17 within the scope of the present invention.

18 Alternatively, the front end ram seals to the polish rod P may be formed of  
19 elastomeric materials such as nitrile rubber seals, as is well known for BOP rams. In  
20 Figures 7 - 9, the front ends of the rams 17, 18 are shown to include an elastomeric  
21 seal 75 molded into grooves (not shown, but located below the seal 75) formed in the  
22 steel ram body 76. The front seal face portion 77 of seal 75 protrudes from the front of  
23 the ram 17, 18 to seal against the polish rod P. The seal 75 preferably includes  
24 longitudinal side rib portions 78 which extend radially outwardly from the sides of the  
25 steel ram body 76. The seal 75 also preferably includes a circumferential ring seal  
26 portion 79 at its rear end 74 (in the case of second ram 18) or adjacent the extended  
27 central bore sealing section 70 (in the case of the first ram 17). This circumferential

1 ring seal portion 79 seals the rams 17, 18 against the ram bores 13, 14. The rams 17,  
2 18 include, at their front ends 71, 73, the vertical radial groove 36 formed in both the  
3 steel ram body 76 and in the seal 75 to accommodate the polish rod P.

4 Alternatively, as shown in FIGS 10 - 11, the front end ram seals to the polish rod  
5 P may be formed such that the front of the steel ram body 76 is provided with a molded  
6 surface of an elastomeric material, or is connected to a block of stiff thermoplastic  
7 material (both are generally shown at 80), such as urethane. As above, the front ends  
8 71, 73 of the rams 17, 18 are formed with the vertical radial groove 36 to accommodate  
9 the polish rod P. As shown in Figure 11, the ram 17, 18 preferably includes a  
10 circumferential seal 82 at its rear end 74 (for second ram 18) or adjacent the extended  
11 central bore sealing section 70 (for ram 17).

12 The extended central bore sealing section 70 of the first ram 17 is shown with  
13 alternate types of seals for sealing across the central bore 12 when the ram 17 is in the  
14 central bore closing position, as described below.

15 In Figures 1 - 5 and 7 - 12, the ram 17 is shown to carry elastomeric seals in the  
16 central bore sealing section 70, configured with a pair of circumferential ring seals 83  
17 and a pair of rib seals 84. The ring seals 83 are spaced from each other along the  
18 central bore sealing section 70 such that they span the central bore 12 when in the  
19 central bore closing position, and thus seal in each of the ram bores 13, 14 against  
20 pressure from the central bore 12. The rib seals 84 extend longitudinally between the  
21 ring seals 83 and extend radially outwardly from the ram body 25. When in the central  
22 bore closing position, the rib seals 84 span and seal the central bore 12 along the  
23 sealing surfaces formed across the wall surface of the central bore 12 at the  
24 intersection with the ram bores 13, 14. It will be noted that the rams 17, as shown in  
25 Figures 8 and 9, differ from each other in that the front circumferential ring seal 79  
26 shown in Figure 8 is omitted in Figure 9, having been replaced by the circumferential  
27 ring seal 83 of the central bore sealing section 70.

1           In Figure 6, a ram 17 is shown to carry elastomeric seals in the central bore  
2 sealing section 70, configured as a saddle shaped seal 85 (i.e., extending down and  
3 along the sides of the upper cylindrical surface of the ram 17 in a saddle-like manner).  
4 The saddle seal 85 is formed in grooves (not shown) on the upper surface of the central  
5 bore sealing section 70, and is shaped and sized to span and seal against the sealing  
6 surfaces formed at the intersection of the central bore 12 and ram bores 13, 14 when in  
7 the central bore closing position.

8           In Figures 13 - 16, a ram 17 is shown to include a thermoplastic seal configured  
9 as a saddle shaped seal 86 in the central bore sealing section 70. As in Figure 6, the  
10 saddle seal 86 is formed in grooves (not shown) on the upper surface of the central  
11 bore sealing section 70, and is shaped and sized to span and seal against the sealing  
12 surfaces formed at the intersection of the central bore 12 and ram bores 13, 14 when in  
13 the central bore closing position. However, being formed of a thermoplastic material, in  
14 order to effect the seal to the central bore 12, a means for upwardly lifting the extended  
15 bore sealing section 70 as it moves into its central bore closing position, is included. To  
16 that end, front and rear spaced, downwardly projecting feet 87, 88 are formed at the  
17 lower surface of the extended central bore sealing section. It should be understood that  
18 the term "feet", as used herein and in the claims, includes alternate lifters, for example  
19 longitudinally extending stepped ridges. The front foot 87 is slightly shorter than rear  
20 foot 88. Channels 89, 90 are formed in each of the ram bores 13, 14 to accommodate  
21 the feet 87, 88. As shown, the channels 89, 90 are stepped adjacent the central bore  
22 (see steps A, B, and C in Figure 15, with the rams removed but with lines showing the  
23 progressive heights of the three steps). The stepped channels 89, 90 at the central  
24 bore 12 are located and sized to lift the central bore sealing section 70, and thus the  
25 saddle seal 86, as the feet 87 and 88 simultaneously engage and rise on steps A and B  
26 respectively. Thus, in the central bore closing position shown in Figure 13, the  
27 thermoplastic saddle seal 86 is lifted upwardly to seal the central bore 12.

28           In Figure 17, the extended central bore sealing section 70 of the steel ram body

1 component 25 is formed in two separate parts 91, 92, with the top section 91 carrying a  
2 thermoplastic saddle seal 93, much as described above. Upwardly biasing springs  
3 (shown schematically as dotted lines in Figure 17) are positioned between the parts 91,  
4 92 such that the thermoplastic saddle seal 93 is lifted upwardly to seal against the  
5 central bore 12 in the central bore closing position.

6 In Figure 18, the front seal components described above for Figures 1 - 6,  
7 including the body component 25 and the seal component 26, extend across the central  
8 bore sealing section 70 to the rear end 72 of the first ram 17. This effectively provides  
9 yet another means to upwardly lift the thermoplastic seal component when the front  
10 ends 71, 73 of the two rams 17, 18 contact each other in the central bore closing  
11 position. The seal component 26 is pressed against the seal support surface 27a of the  
12 body component 25 such that the upper surface of the seal component 26, and the  
13 raised ridge 38 (thermoplastic sealing surface) is compressed outwardly to seal against  
14 the central bore 12 and the ram bores 13, 14.

15 The invention also extends to a composite wellhead assembly including,  
16 between its top connector and bottom connector, a blowout preventer as described  
17 above, together with one or more of the following components, in any sequence,  
18 adapters, valves, gate valves, flow tee, additional blowout preventers, and polish rod  
19 clamp. To that end, attention is directed to the devices disclosed in the following U.S.  
20 Patents, all of which are commonly owned by Stream-Flo Industries Ltd.: U.S.  
21 5,743,332, issued April 28, 1998, entitled "Integral Wellhead Assembly for Pumping  
22 Wells"; U.S. 6,457,530, issued October 1, 2002, entitled "Wellhead Production Pumping  
23 Tree"; U.S. 6,176,466, issued January 23, 2001, entitled "Composite Pumping Tree  
24 with Integral Shut-Off Valve"; and U.S. 6,595,278, issued July 22, 2003, entitled  
25 "Assembly for Locking a Polished Rod in a Pumping Wellhead". Each of these patents  
26 discloses wellhead equipment used in connection with pumping oil wells, but in a  
27 composite form, meaning that one or more functional components of a conventional  
28 pumping tree are included in an integral body housing between a top and a bottom

1 connector. Such components may include a shut off valve, a blowout preventer, a flow  
2 tee and an adapter. Figure 12 shows one such composite wellhead assembly in  
3 accordance with this invention to include a integral tubular body 100, formed from a  
4 single piece of steel, and forming an axial, vertical or central fluid flow bore 102  
5 extending therethrough. Multiple side openings 103 are formed in the body 100, each  
6 communicating with the vertical bore 102, in order to house the valve, BOP and flow tee  
7 components, as set forth below. The body 100 includes a bottom connector 104 for  
8 connection with the component located therebelow (not shown, but for example the  
9 flanged top connection of a tubing head). Although shown as a studded down  
10 connection, the bottom connector can be any type of bottom connector such as a  
11 flanged connection, clamp-hub connection, rotatable flange connection, welded  
12 connection or threaded connection. The body 100 includes a valve housing section  
13 106 above the bottom connection housing a conventional gate valve assembly 108,  
14 operative to open or close the bore 102. Above the valve housing section 106 is a first  
15 BOP housing section 110, which houses the ram assembly components 112 of Figure  
16 1, as described above. The ram assembly components of any of the above described  
17 embodiments of this invention may be used in this section 110. A second BOP housing  
18 section 114 is formed in the body 100 above the first BOP housing section 110. As  
19 shown in Figure 12, ram assembly components 116 are shown carrying thermoplastic  
20 seal components as described in U.S. Patent 7,137,610. Any other BOP ram assembly  
21 components may be substituted in this section 116. Above the second BOP housing  
22 114 is a flow tee housing section 118 for connection with a conventional flow line (not  
23 shown), through which well fluid is produced. The body 100 forms a top connector 120  
24 at its upper end for connection with the wellhead component located thereabove,  
25 typically a stuffing box (not shown). Figure 12 shows the top connector 120 as studded  
26 connectors, but any other type of connector may be substituted, as known in the art.  
27 As indicated, this is only one exemplary composite wellhead assembly. The  
28 components may be provided in different sequences, and may be varied, added or  
29 omitted as is appropriate for the needs of a particular wellhead.

1 All references mentioned in this specification are indicative of the level of skill in  
2 the art of this invention. Some references provided herein are included to provide  
3 details concerning the state of the art prior to the filing of this application, other  
4 references may be cited to provide additional or alternative device elements, additional  
5 or alternative materials, additional or alternative methods of analysis or application of  
6 the invention.

7 The terms and expressions used are, unless otherwise defined herein, used as  
8 terms of description and not limitation. There is no intention, in using such terms and  
9 expressions, of excluding equivalents of the features illustrated and described, it being  
10 recognized that the scope of the invention is defined and limited only by the claims  
11 which follow. Although the description herein contains many specifics, these should not  
12 be construed as limiting the scope of the invention, but as merely providing illustrations  
13 of some of the embodiments of the invention. One of ordinary skill in the art will  
14 appreciate that elements and materials other than those specifically exemplified can be  
15 employed in the practice of the invention without resort to undue experimentation. All  
16 art-known functional equivalents, of any such elements and materials are intended to  
17 be included in this invention. The invention illustratively described herein suitably may  
18 be practiced in the absence of any element or elements, limitation or limitations which is  
19 not specifically disclosed herein.

1    **WHAT IS CLAIMED IS:**

2    1.    **A production blowout preventer, comprising:**

3           **a housing forming a central bore, which extends vertically through the housing,**  
4    **and a first and a second horizontal ram bore extending radially outwardly in opposite**  
5    **directions through the housing and intersecting the central bore, with sealing surfaces**  
6    **being formed across the wall surfaces at the intersection of the ram and central bores;**

7           **a first ram positioned in the first ram bore for sliding movement therealong;**

8           **a second ram positioned in the second ram bore for sliding movement**

9    **therealong;**

10           **the first and second rams each including a ram body having front and rear ends,**  
11    **each of the ram bodies being slidable along the ram bores so as to project into the**  
12    **central bore where their front ends are adapted to seal against a polish rod of a rod**  
13    **string extending therethrough, and each of the ram bodies optionally carrying one or**  
14    **more seals for sealing against the ram bore in which it is positioned;**

15           **the first ram body including an extended central bore sealing section between its**  
16    **front and rear ends, said central bore sealing section carrying one or more central bore**  
17    **seals for sealing across the central bore when the extended central bore sealing section**  
18    **is positioned across the central bore in a central bore closing position;**

19           **the one or more central bore seals including a saddle shaped seal of a**  
20    **thermoplastic material formed on the upper surface of the extended central bore sealing**  
21    **section and being shaped to span and seal across the central bore when in the central**  
22    **bore closing position;**

23           **the first ram carrying lifting means for upwardly lifting the extended central bore**  
24    **sealing section to cause the saddle shaped thermoplastic seal to seal across the**  
25    **central bore in the central bore closing position;**

26           **the first ram bore being of sufficient length to accommodate the first ram body in**  
27    **its fully extended or fully retracted position;**

28           **the second ram bore being of sufficient length to accommodate the second ram**  
29    **body in its fully extended or fully retracted position, and to also accommodate the front**

- 1 end of the first ram when in the central bore closing position; and  
2 means connected to the rear of each ram body for advancing and withdrawing  
3 the first and second rams between open, sealing and central bore closing positions.
- 4 2. The blowout preventer of claim 1, wherein:  
5 the first and second ram bodies are generally cylindrical; and  
6 the one or more central bore seals on the first ram includes a pair of  
7 circumferential ring seals positioned on the extended central bore sealing section, said  
8 circumferential ring seals being spaced sufficiently to span the central bore when in the  
9 central bore closing position, so as to also seal the first and second ram bores against  
10 pressure from the central bore; and  
11 the first ram includes a pair of rib seals on its outer surface extending radially  
12 outwardly therefrom and extending longitudinally between the circumferential ring seals,  
13 said rib seals being positioned to seal the central bore when in the central bore closing  
14 position.
- 15 3. The blowout preventer of claim 1, wherein the first and second ram bodies are  
16 generally cylindrical.
- 17 4. The blowout preventer of claim 2, wherein the front ends of the first and second  
18 rams are adapted to provide thermoplastic seals to the polish rod.
- 19 5. The blowout preventer of claim 3, wherein the front ends of the first and second  
20 rams are adapted to provide thermoplastic seals to the polish rod.
- 21 6. The blowout preventer of claim 2, wherein the front ends of the first and second  
22 rams are adapted to provide elastomeric seals to the polish rod.
- 23 7. The blowout preventer of claim 3, wherein the front ends of the first and second  
24 rams are adapted to provide elastomeric seals to the polish rod.

1 8. The blowout preventer of claim 2, wherein the front end of the first and second  
2 rams is adapted to seal against each other across the central bore when the polish rod  
3 is not present.

4 9. The blowout preventer of claim 3, wherein the front end of the first and second  
5 rams is adapted to seal against each other across the central bore when the polish rod  
6 is not present.

7 10. The blowout preventer of claim 5, wherein the lifting means includes front and  
8 rear spaced, downwardly projecting feet formed at a lower surface of the extended  
9 central bore sealing section, and a channel formed in each of the first and second ram  
10 bores to accommodate the feet, each of the channels being progressively stepped at  
11 the central bore to force the saddle shaped seal upwardly to seal the central bore as  
12 the feet simultaneously engage the steps in the central bore closing position.

13 11. The blowout preventer of claim 5, wherein the lifting means includes;  
14 the extended central bore sealing section being formed in separate top and  
15 bottom parts, with the top part carrying the saddle shaped thermoplastic seal; and  
16 one or more upwardly biasing springs positioned between the top and bottom  
17 parts such that the thermoplastic saddle shaped seal is lifted upwardly to seal across  
18 the central bore in the central bore closing position.

19 12. The blowout preventer of claim 5, wherein the first and second ram bodies each  
20 has a front end adapted to provide thermoplastic seals to the polish rod, and wherein  
21 each of the first and second ram bodies comprises:

22 a body component with front and rear portions and ends;

23 a seal component with front and rear portions and ends;

24 said body component having an arcuate longitudinal outer surface for  
25 conforming with the horizontal ram bore surfaces, and having a cut-out in its front  
26 portion which provides a seal support surface to support the seal component in both a

1 vertical and horizontal direction;

2 said seal component having an arcuate longitudinal outer surface for conforming  
3 with the horizontal ram bore surfaces, and an inner surface which generally conforms to  
4 the seal support surface of the body component;

5 said body component and seal component combining, in an assembled form, to  
6 form a full bore ram body, which when out of sealing engagement has the front end of  
7 the seal component protruding a horizontal distance beyond the front end of the body  
8 component;

9 connectors for connecting the seal and body components while allowing the seal  
10 component, during sealing engagement, to be pressed against the seal support surface  
11 of the body component; and

12 said seal component providing a sealing surface formed of thermoplastic  
13 material around the arcuate outer surface for sealing against the horizontal ram bore;

14 so that, as the body component is advanced forwardly into a sealing  
15 engagement causing the front end of the seal component to contact either the adjacent  
16 ram or the polish rod to seal off the central bore, the seal component is pressed against  
17 the seal support surface of the body component such that the thermoplastic sealing  
18 surface is compressed outwardly to seal against the horizontal ram bore.

19 13. The blowout preventer of claim 12, wherein the body and seal components of the  
20 first ram extend across the extended central bore sealing section to the rear end of the  
21 first ram, such that when in central bore closing position, the front end of the first ram  
22 seal component contacts the second ram causing the first ram seal component to be  
23 pressed against the seal support surface of the first ram body component such that its  
24 thermoplastic sealing surface is compressed outwardly to seal across the central bore.

25 14. The blowout preventer of claim 1, wherein the housing provides top and bottom  
26 connectors for connecting and sealing to wellhead components located above and  
27 below the housing.

1 15. A composite wellhead assembly including, between its top connector and bottom  
2 connector, the blowout preventer of claim 1, together with one or more of the following  
3 wellhead components, in any sequence: an adapter, a valve, a gate valve, a flow tee, a  
4 blowout preventer, and a polish rod clamp.

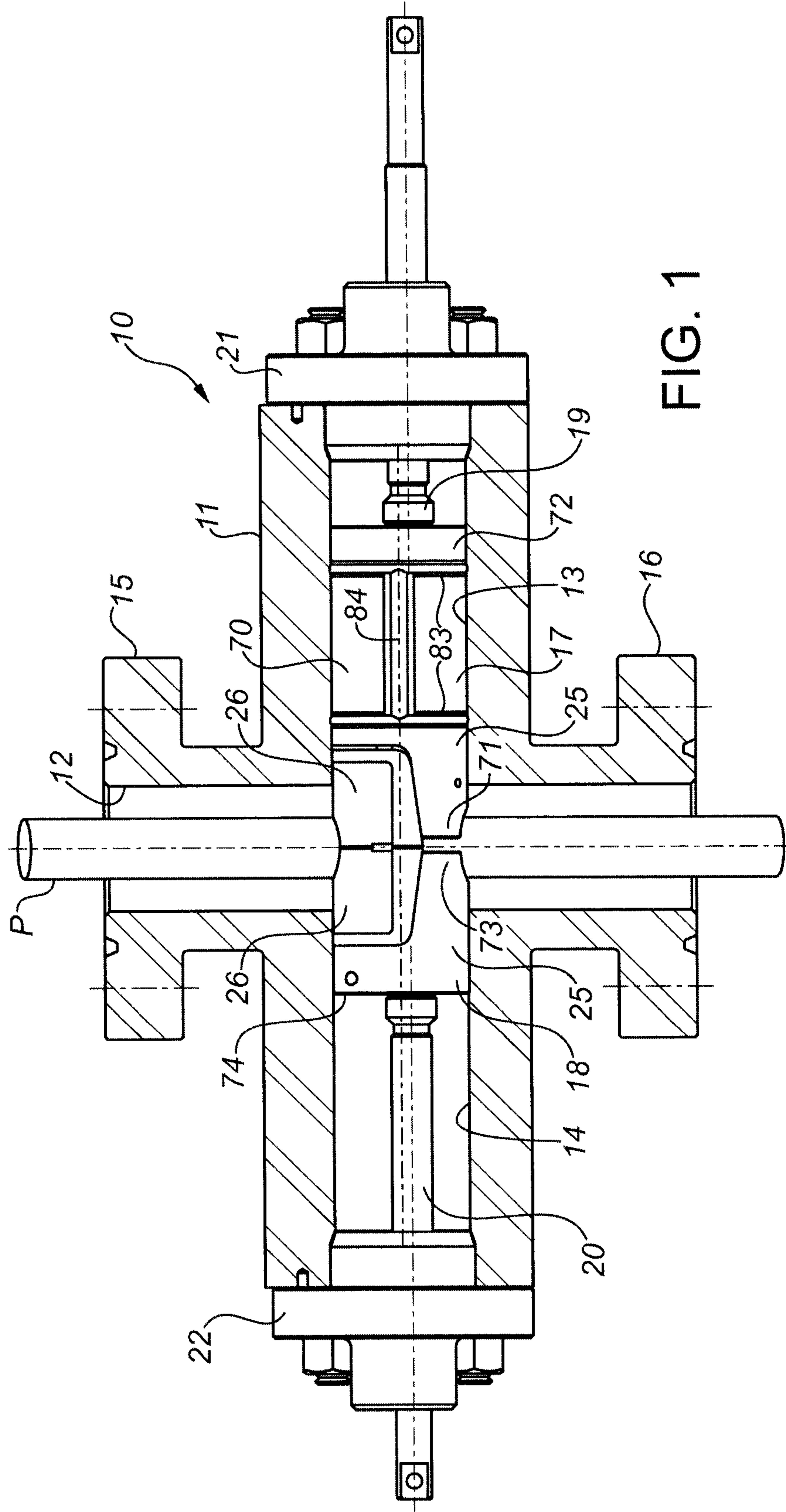



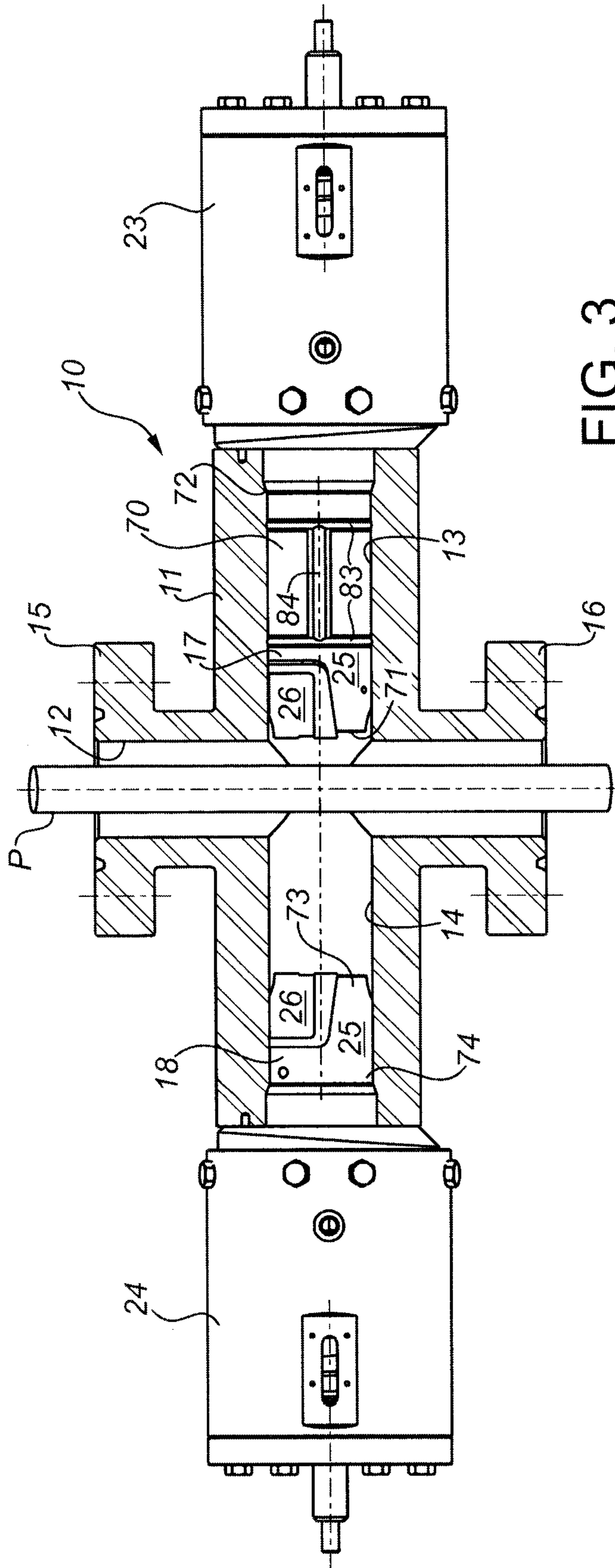

FIG. 3

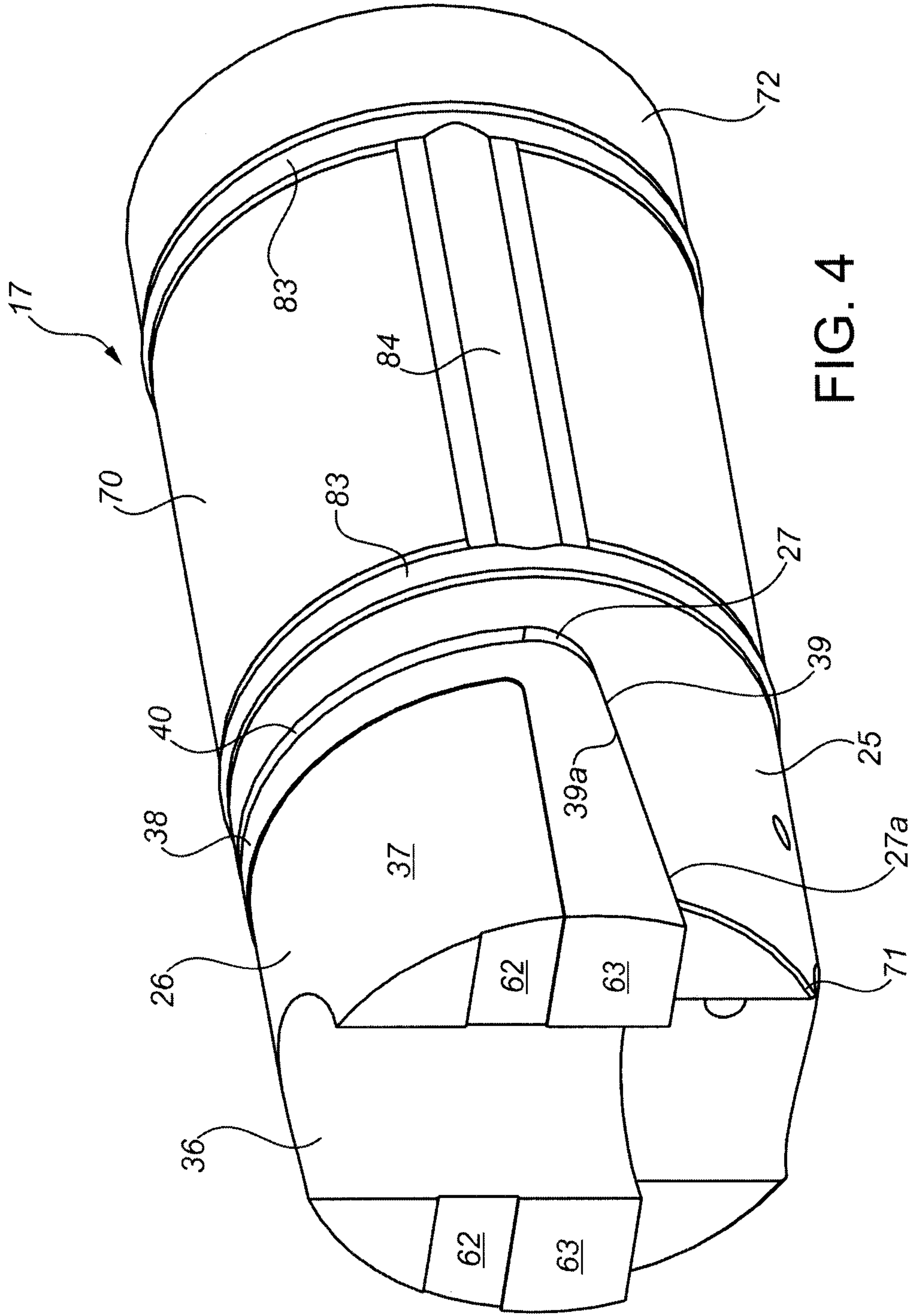

FIG. 4

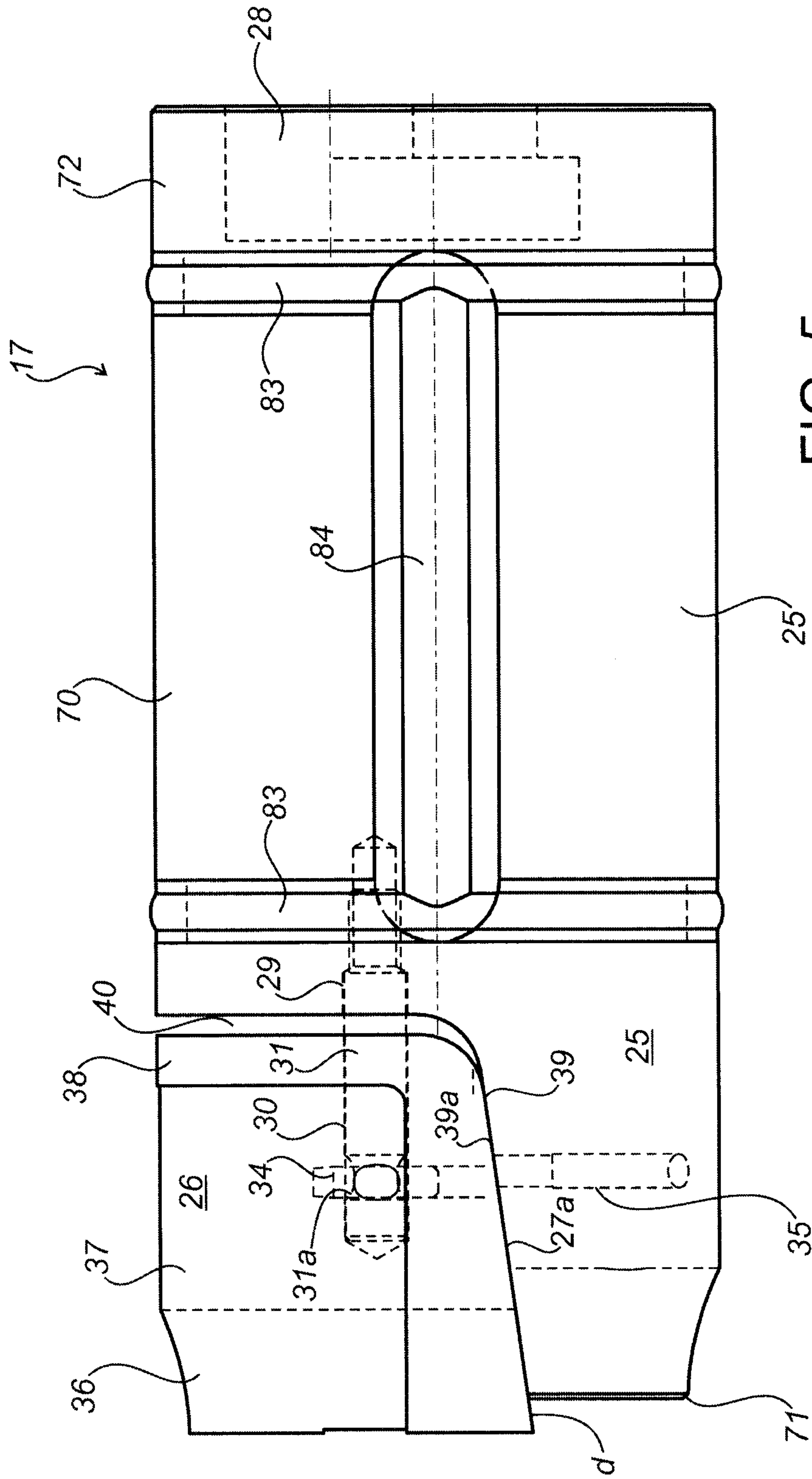

FIG. 5

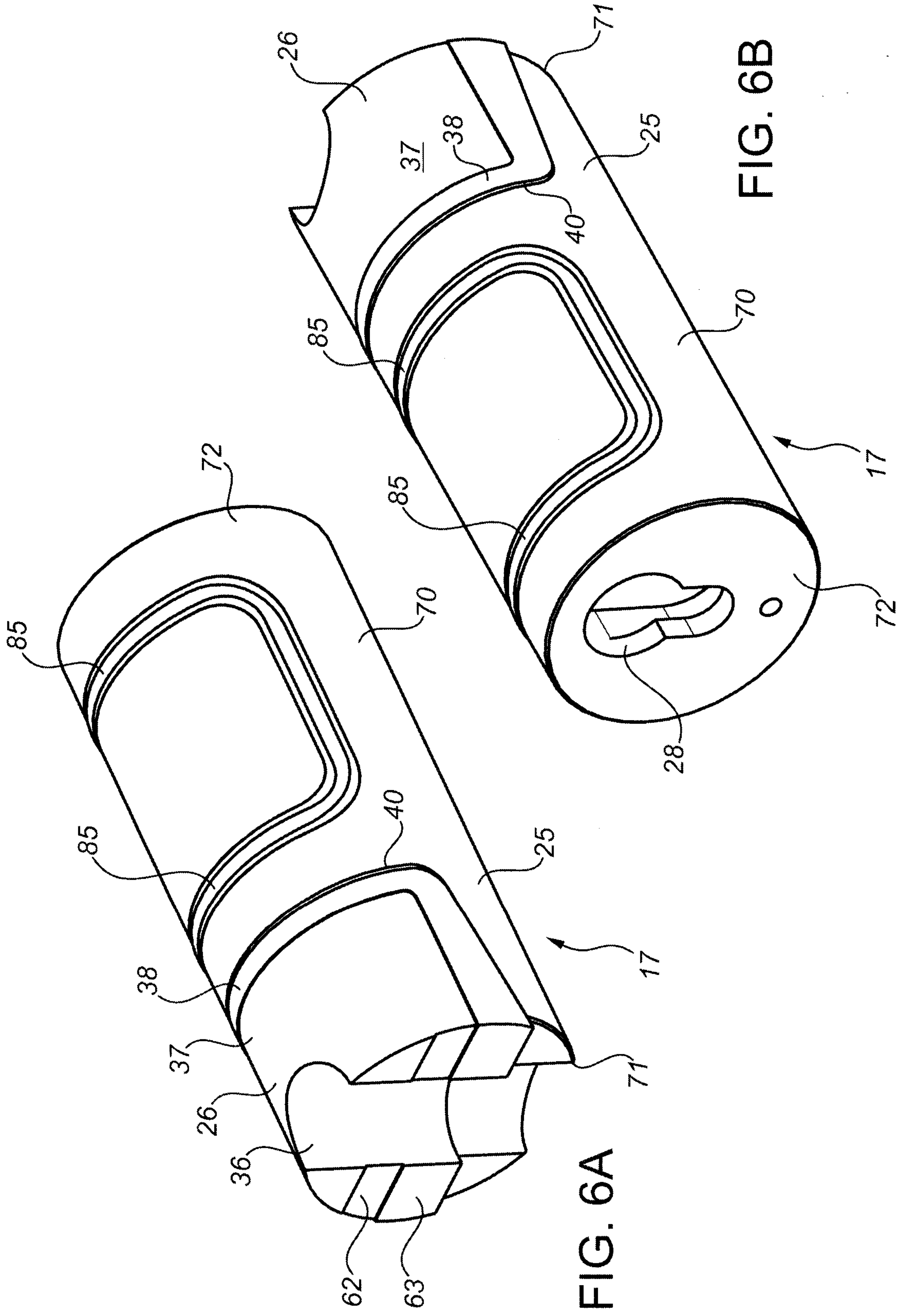

FIG. 6A

FIG. 6B

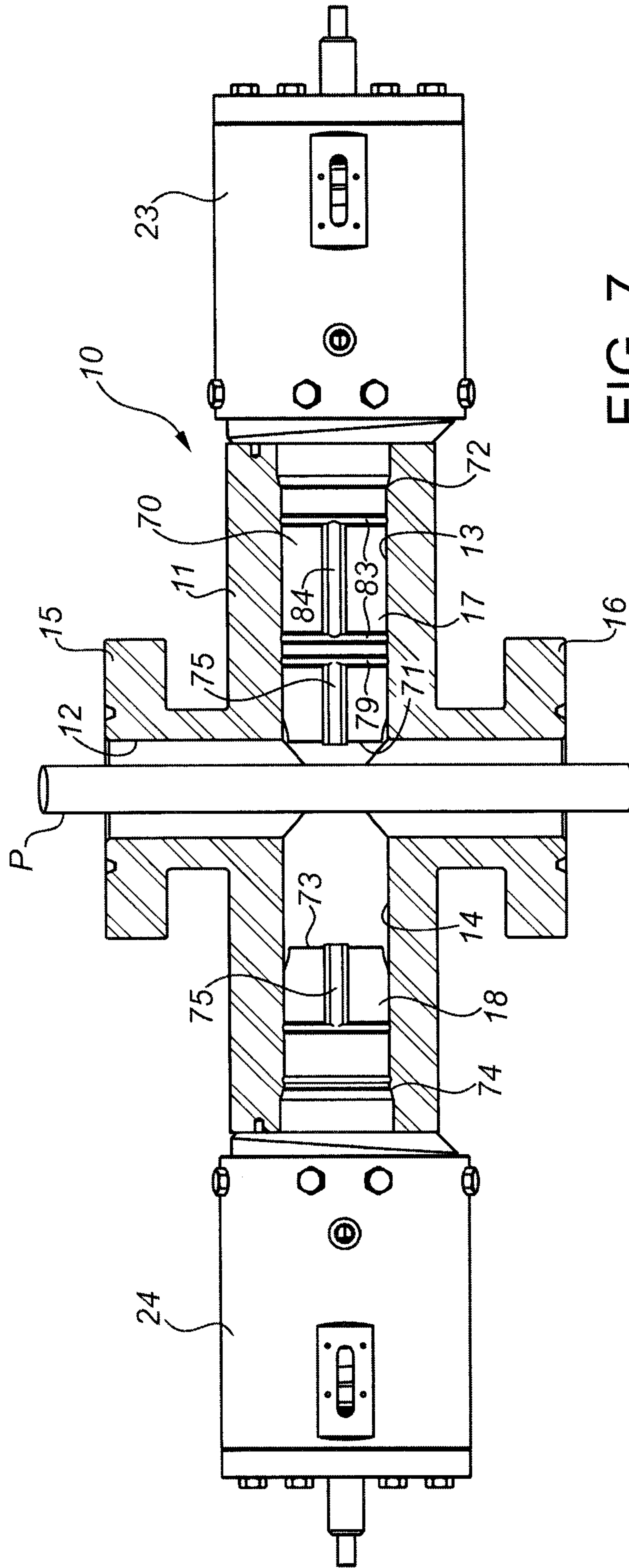
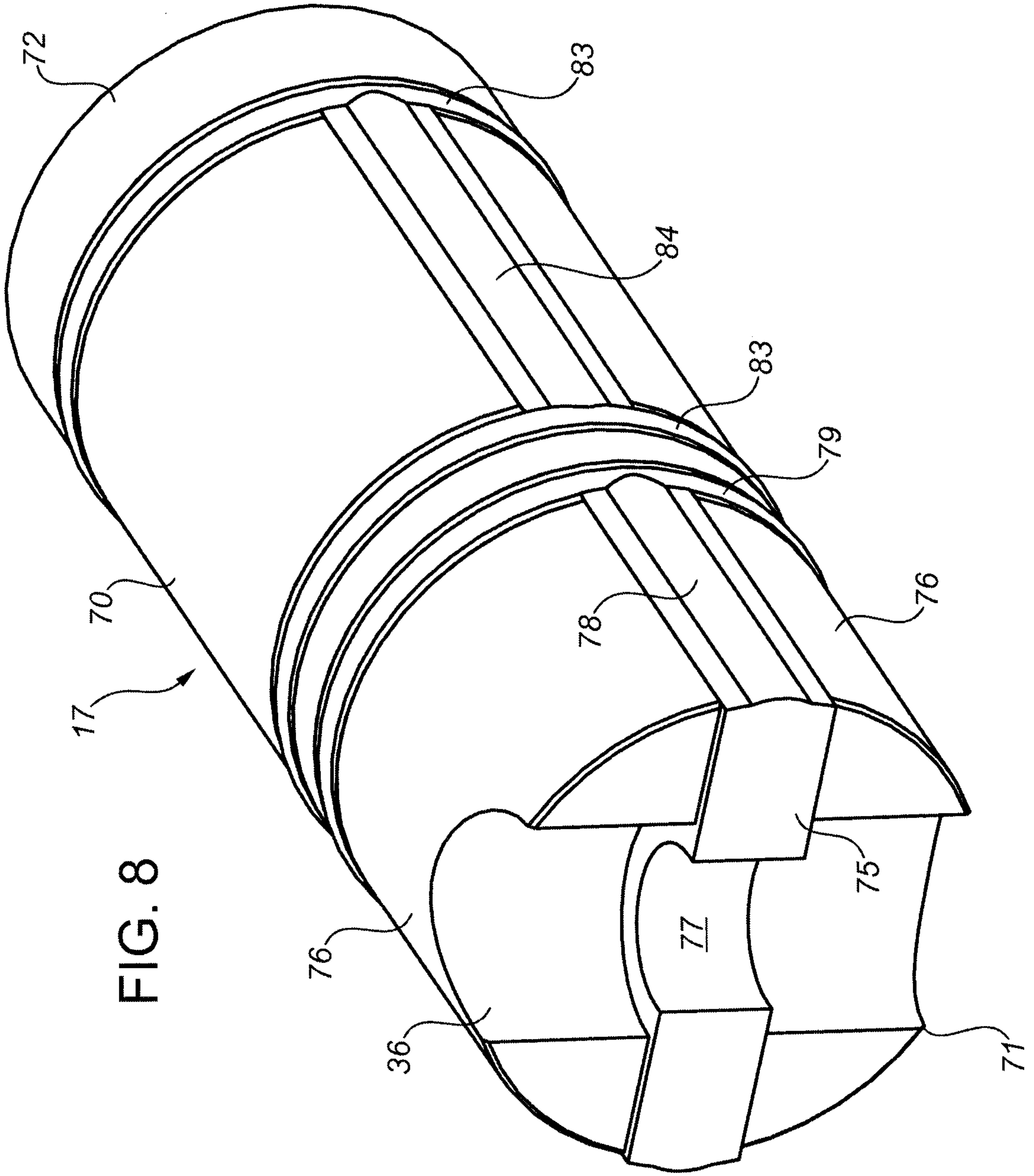

FIG. 7



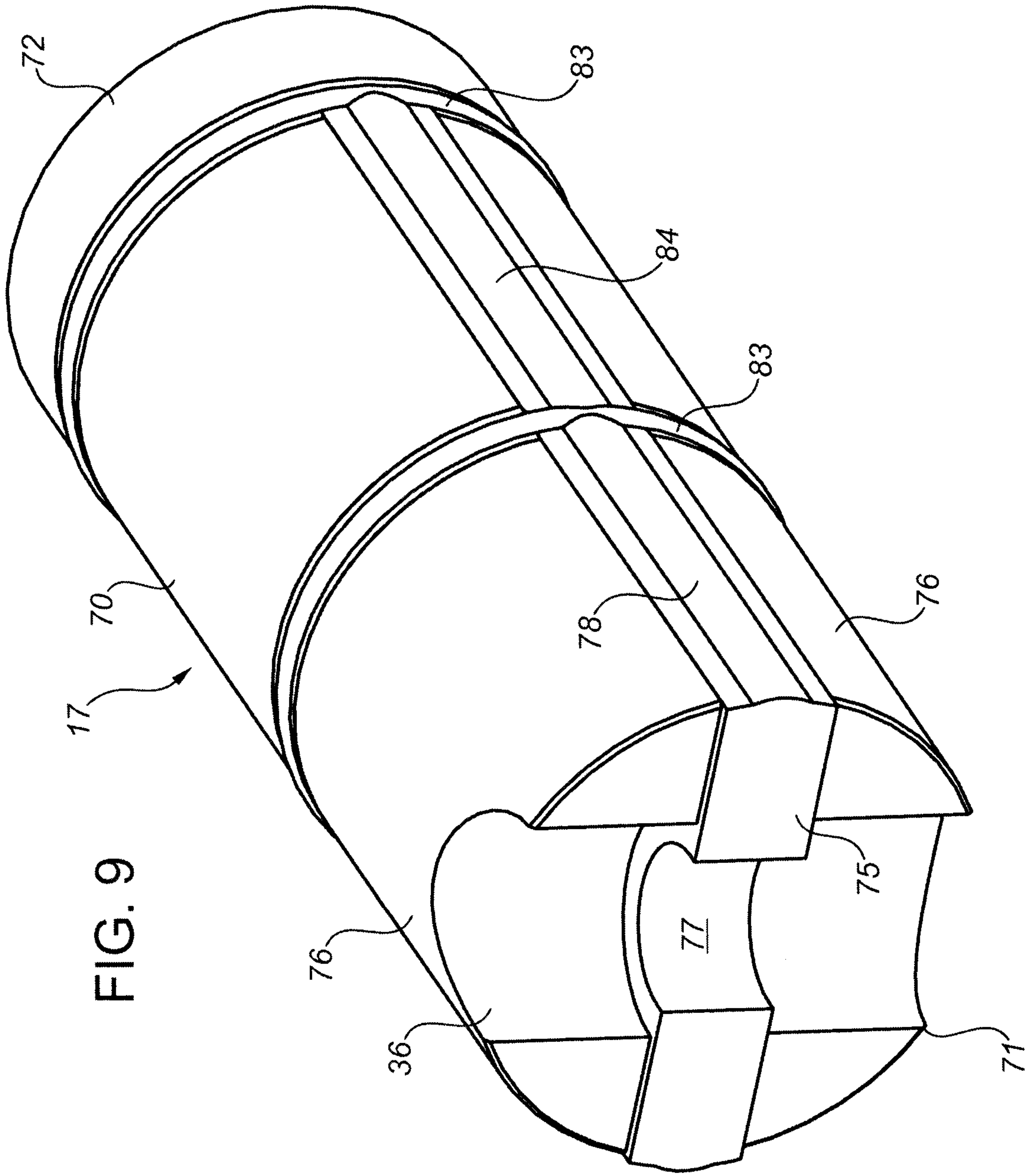

FIG. 9

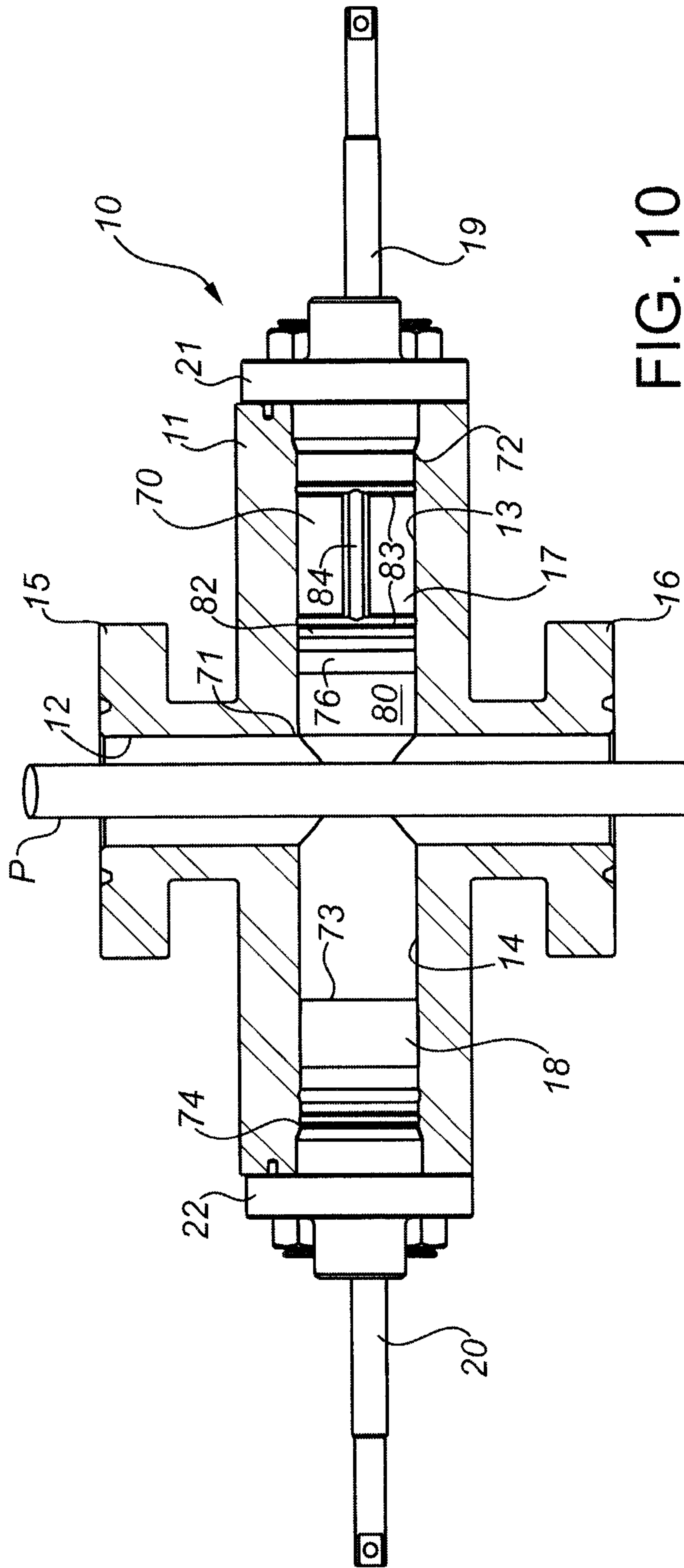



FIG. 12

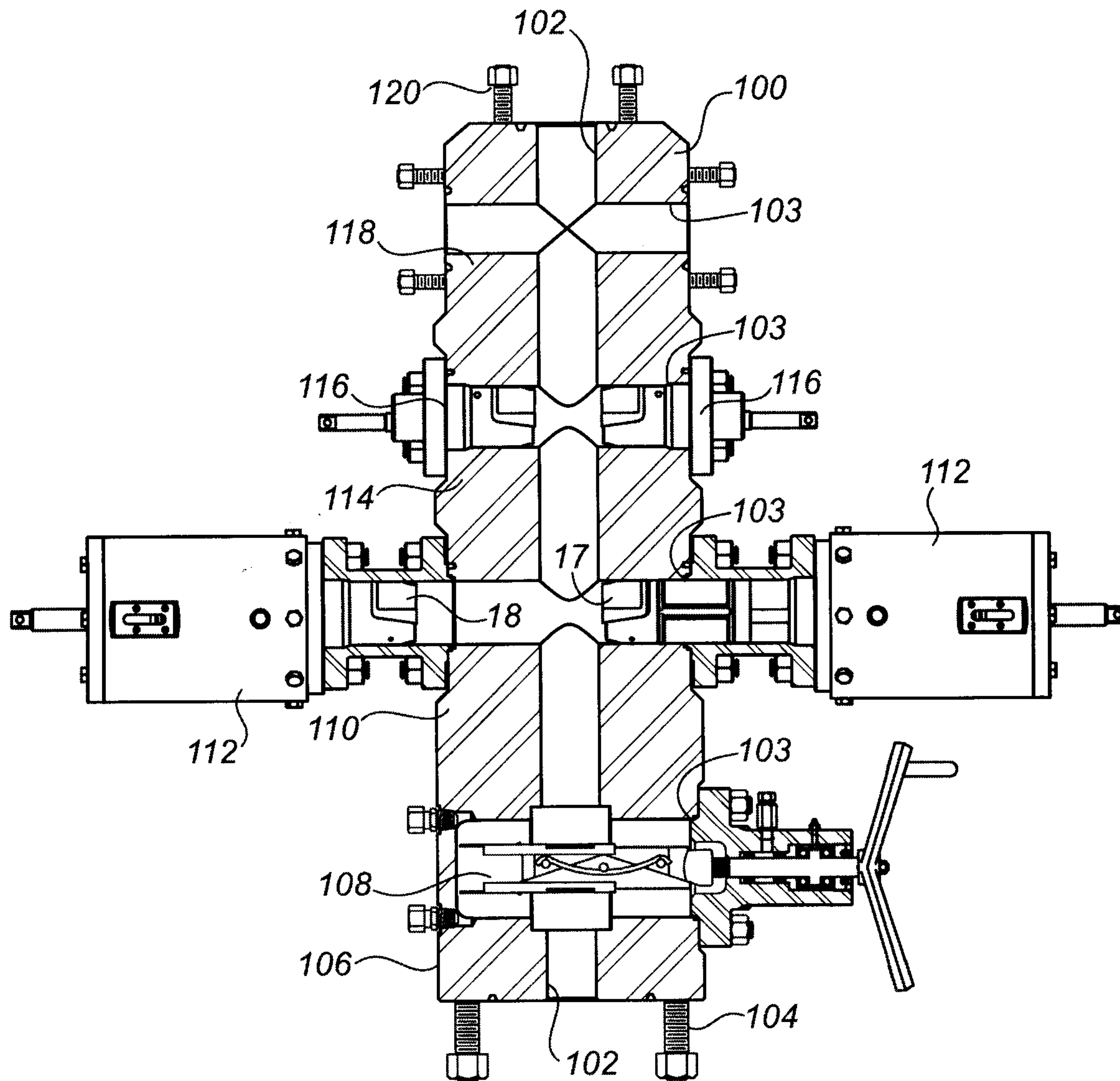
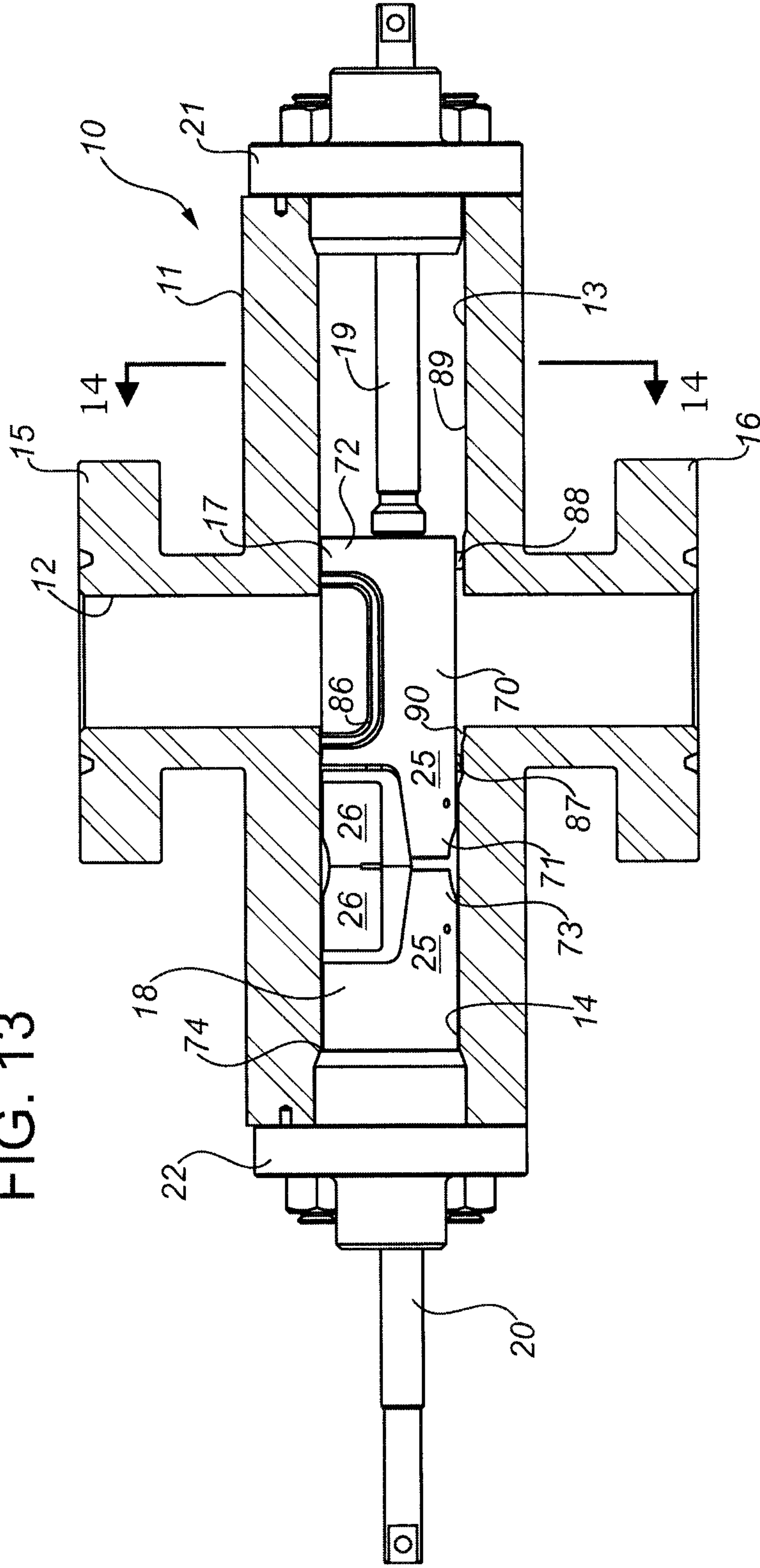

FIG. 13



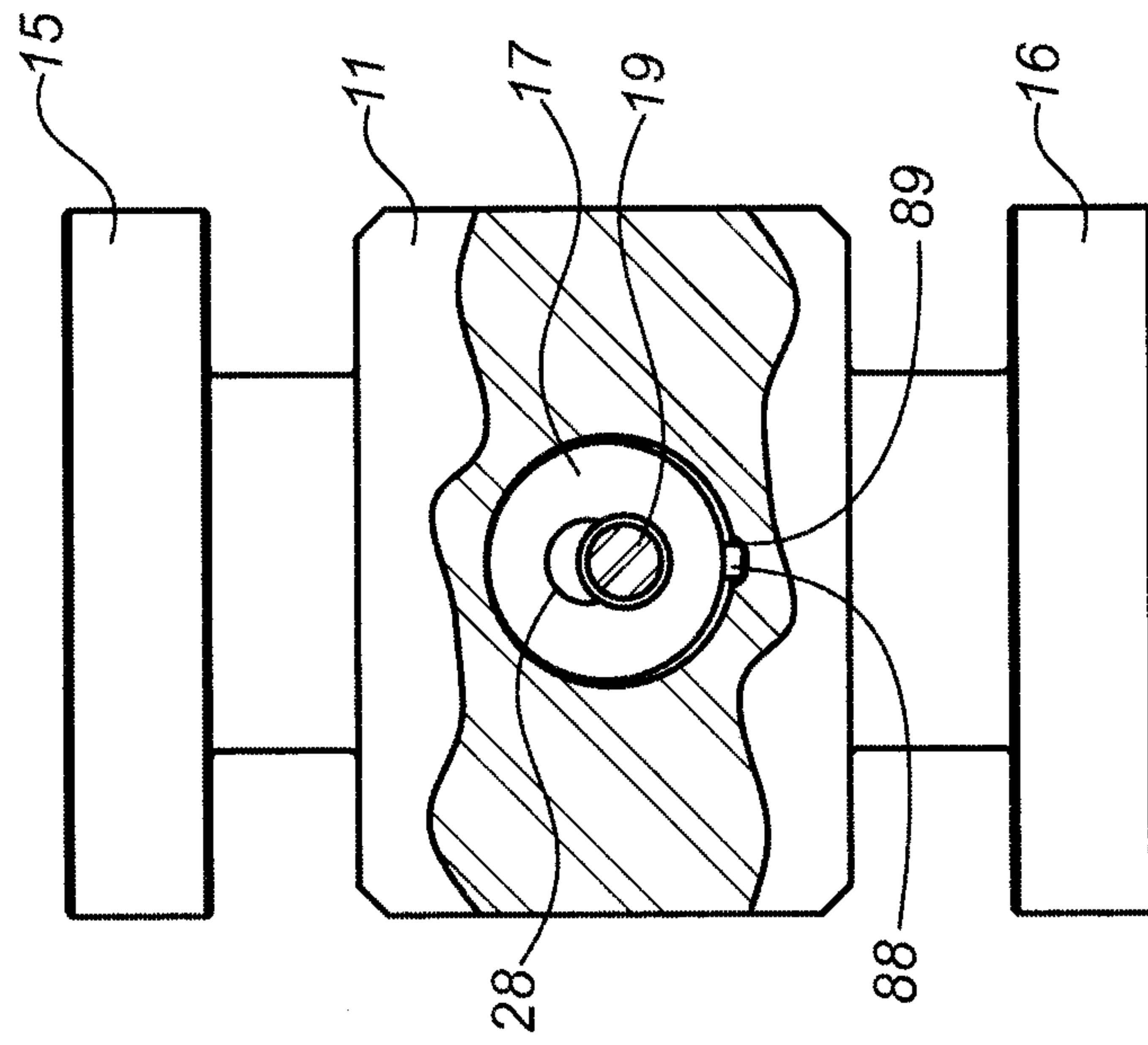

FIG. 14

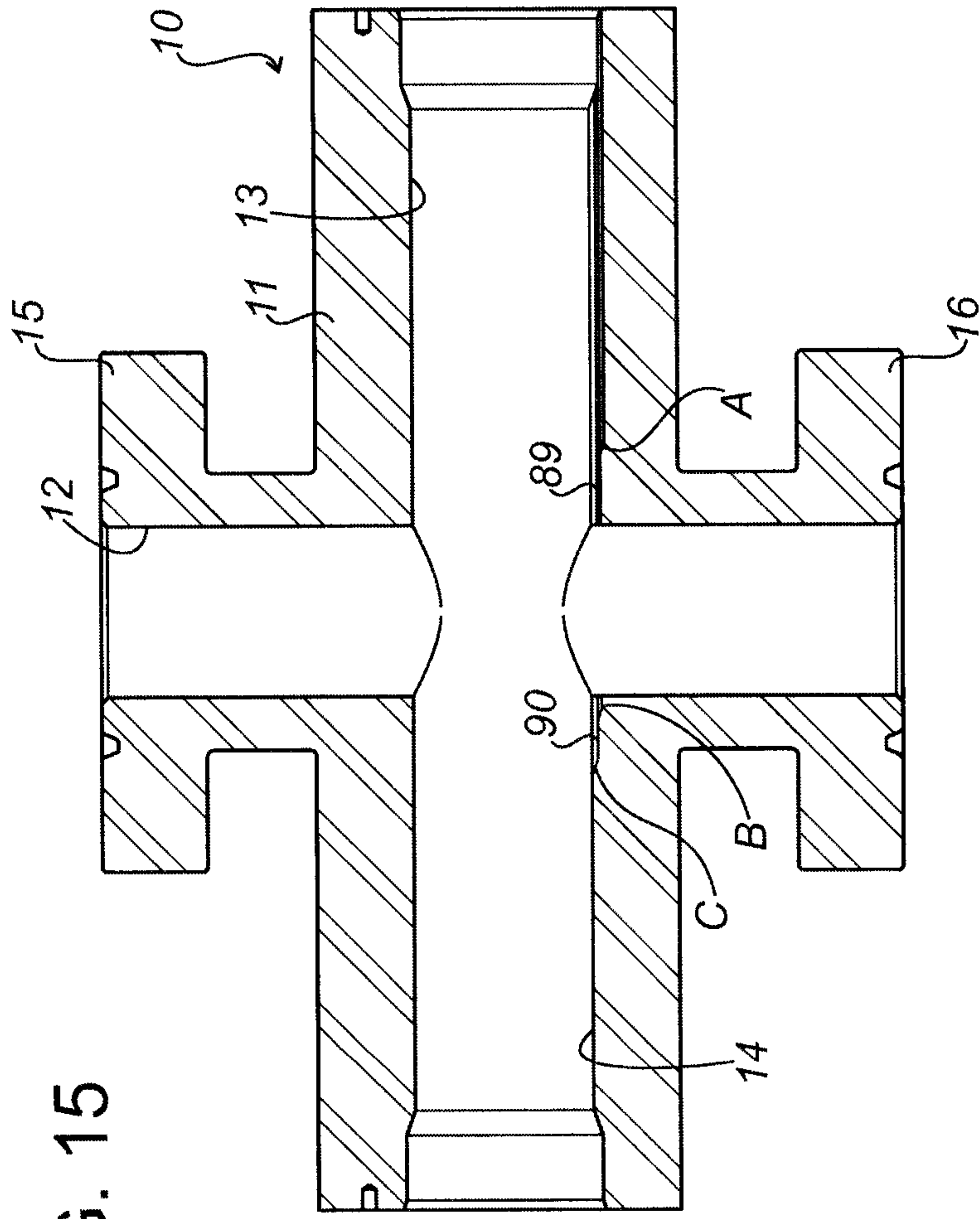

FIG. 15

FIG. 16

