

(19) World Intellectual Property Organization  
International Bureau



(43) International Publication Date  
16 March 2006 (16.03.2006)

PCT

(10) International Publication Number  
WO 2006/029395 A1

(51) International Patent Classification: <sup>7</sup> A46B 9/04,  
13/00, A61C 17/00

(21) International Application Number:  
PCT/US2005/032436

(22) International Filing Date:  
9 September 2005 (09.09.2005)

(25) Filing Language: English

(26) Publication Language: English

(30) Priority Data:  
60/609,093 9 September 2004 (09.09.2004) US

(71) Applicant and

(72) Inventor: HEGEMANN, Kenneth, J. [US/US]; 701  
South Andreason Drive, Unit C, Escondido, CA 92029  
(US).

(72) Inventors; and

(75) Inventors/Applicants (for US only): HEGEMANN, Rob  
[US/US]; 701 South Andreason Drive, Unit C, Escondido,  
CA 92029 (US). HEGEMANN, Jay [US/US]; 701 South  
Andreason Drive, Unit C, Escondido, CA 92029 (US).

(74) Agents: SCULL, Peter, B. et al.; Hensley Kim & Edg-  
ington, LLC, 1660 Lincoln Street, Suite 3050, Denver, CO  
80264 (US).

(81) Designated States (unless otherwise indicated, for every  
kind of national protection available): AE, AG, AL, AM,  
AT, AU, AZ, BA, BB, BG, BR, BW, BY, BZ, CA, CH, CN,  
CO, CR, CU, CZ, DE, DK, DM, DZ, EC, EE, EG, ES, FI,  
GB, GD, GE, GH, GM, HR, HU, ID, IL, IN, IS, JP, KE,  
KG, KM, KP, KR, KZ, LC, LK, LR, LS, LT, LU, LV, MA,  
MD, MG, MK, MN, MW, MX, MZ, NA, NG, NI, NO, NZ,  
OM, PG, PH, PL, PT, RO, RU, SC, SD, SE, SG, SK, SL,  
SM, SY, TJ, TM, TN, TR, TT, TZ, UA, UG, US, UZ, VC,  
VN, YU, ZA, ZM, ZW.

(84) Designated States (unless otherwise indicated, for every  
kind of regional protection available): ARIPO (BW, GH,  
GM, KE, LS, MW, MZ, NA, SD, SL, SZ, TZ, UG, ZM,  
ZW), Eurasian (AM, AZ, BY, KG, KZ, MD, RU, TJ, TM),  
European (AT, BE, BG, CH, CY, CZ, DE, DK, EE, ES, FI,  
FR, GB, GR, HU, IE, IS, IT, LT, LU, LV, MC, NL, PL, PT,  
RO, SE, SI, SK, TR), OAPI (BF, BJ, CF, CG, CI, CM, GA,  
GN, GQ, GW, ML, MR, NE, SN, TD, TG).

**Published:**

- with international search report
- before the expiration of the time limit for amending the  
claims and to be republished in the event of receipt of  
amendments

For two-letter codes and other abbreviations, refer to the "Guid-  
ance Notes on Codes and Abbreviations" appearing at the begin-  
ning of each regular issue of the PCT Gazette.

(54) Title: ORAL BRUSHING DEVICES AND/OR METHODS

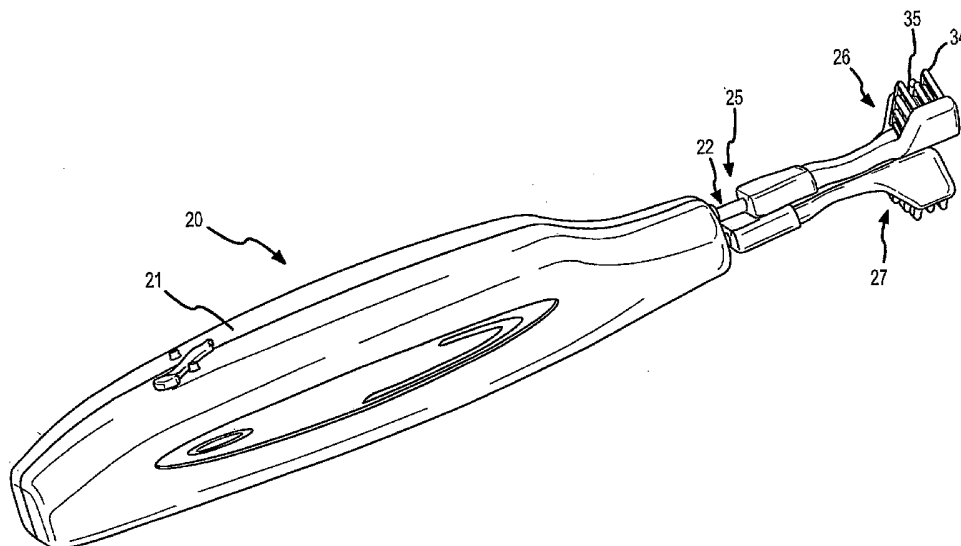

(57) Abstract: An oral hygiene device (20) having one or more toothbrushes (26, 27) disposed connected to the end of a handle (21), the toothbrush or toothbrushes providing a desirable fit about the teeth (56, 57) and/or gums and/or providing a desirable brushing action. An oral hygiene device hereof may provide for mechanically mimicking the brushing movements of the most widely professionally recommended manual tooth-brushing method known as the "Bass" or "Modified Bass" technique, to thus reduce or eliminate the element of human error associated with brushing of a user's teeth and gums.

WO 2006/029395 A1

## ORAL BRUSHING DEVICES AND/OR METHODS

### BACKGROUND

[0001] The present invention relates generally to oral cleansing devices and more particularly to power driven tooth and/or gum brushing devices, and also relates, in many embodiments, to a system for using or moving one or more cleaning or brushing heads during a cleaning procedure. This may commonly include providing reciprocal cleaning head movement. Particularly useful herewith may be one or more toothbrush or like arrangements which assist in orienting and guiding the cleansing heads within the user's mouth to provide proper cleansing and stimulation to thereby produce healthy teeth and gums.

[0002] A large proportion of the adult population suffers from some form of gum disease which in turn can and often does lead to tooth loss. An important cause of gum disease is inadequate gum brushing and massage. And, in response, a diverse array of manual and automated tooth cleansing devices have been developed including electric toothbrushes, oral irrigators and automated flossers. These have been generally directed at the important basic need to clean the teeth, gums and certain parts or the whole of the mouth area. Nonetheless, many deficiencies remain with various of these devices, and for many people and in many situations, they are inadequate or unsuitable. Manual brushes, for instance, require the user to have a minimum, moderate degree of manual dexterity and the ability to firmly grasp the brush while moving it against the dental surfaces. The tiresomeness, repetitiveness and difficulty of and/or the relative disinterestedness of many people with manual brushing leads many to do less than is necessary, often also using inappropriate brushing methods. And thus, some tooth and gum surfaces may receive inadequate brushing or may be missed altogether.

[0003] Furthermore, conventional electric or "power" toothbrushes, while often requiring less physical effort on the part of the user, still generally require human skill and dexterity, i.e., accurate human manipulation in order to achieve effective disease preventing

results. And, these power brushes are often more complicated than manual brushes and are more expensive and require more time in maintenance. Moreover, brushing too vigorously with electric brushes can irritate the gums or cause them to bleed excessively, possibly injuring the gums or eventually causing them to recede.

[0004] Thus, present means of tooth and gum brushing or cleaning may be inadequate for many or even most users. Many prior means and methods are not readily capable of effective operation; hygienic, comfortable, and/or error-free use; simple and inexpensive maintenance; with a cost-effective purchase price, for most people in most situations. Thus, there is a need for an improved cleaning device to fill one or more of these needs.

[0005] The present invention is presented as a means to remedy one or more of the above-mentioned drawbacks of past devices and/or methods with the provision of a dental care device which offers effective means of dental care for people of all ages, including those with natural teeth or implants, crowns, braces and bridgework, as well as for people of limited dexterity, or having other handicaps.

#### SUMMARY OF THE INVENTION

[0006] The present invention provides a dental cleaning appliance for cleaning teeth and gums, the appliance having one or more cleaning heads which are insertable into the user's mouth for the cleaning operation, the cleaning head or heads being attached to a power handle which activates movement of the cleaning head or heads which each may include one or more brushing heads and one or more brushing arms, the one or more brushing heads being reciprocable in many embodiments, and also being disposed so as to include in further embodiments a set of upper brushes and a set of lower brushes, each of said sets of upper and lower brushes often being reciprocable in alternating opposing dispositions relative to each other. Such brush heads may also be used to definitively establish the position of the brushes in the user's mouth and maintain this position so that the bristles may effectively work on the tooth and gum surfaces and/or at the gum line (or elsewhere, if desired) as may be most appropriate for cleaning and improving oral health.

[0007] Accordingly, an aspect of the present invention is to provide an oral cleaning device including one or more brushes or other cleaning devices which may be positioned by a cleansing head in a substantially pre-selected position for cleaning and massaging of the user's teeth and gums. Another aspect of the present invention may be to provide an oral cleaning device including one or more brushes which are disposed in, on or adjacent a brush head assembly such that the bristles may be accurately positioned by or with assistance of the brush head assembly in a pre-selected disposition to provide for accurate brushing, cleaning and massaging of the user's teeth and gums. And yet another aspect of the present invention may be to provide a device in which one or more brushes may be moved such that the brushes selectively move with the cleansing head to activate the tooth and gum cleansing process with a moving bristle pattern (direction and angle) meeting the needs of a user while substantially eliminating human error. A further aspect may be in providing an oral hygiene device which provides for mechanically mimicking the brushing movements of the most widely professionally recommended manual tooth-brushing method known as the "Bass" or "Modified Bass" technique, to thus reduce or eliminate an element of human error associated with brushing of a user's teeth and gums.

[0008] These and still further aspects as shall hereinafter appear are readily fulfilled by the present invention in a remarkably unexpected manner as will be readily discerned from the following detailed description of exemplary embodiments hereof especially when read in conjunction with the accompanying drawings in which like parts bear like numerals throughout the several views.

#### BRIEF DESCRIPTION OF THE DRAWINGS

[0009] In the drawings:

FIG. 1 is an isometric view of an oral cleaning device described herein;

FIG. 2 is an isometric view of a cut-away portion of an oral cleaning device as described herein;

FIG. 3, which includes subpart FIGs. 3A, 3B, 3C, 3D and 3E, provides respective isometric and elevational views of exemplary brushes for use as part of an oral cleaning device or system as described herein;

FIG. 4, which includes subpart FIGs. 4A, 4B and 4C, provides respective elevational and plan views of exemplary brushes as they may be in use according hereto;

FIG. 5, which includes subpart FIGs. 5A, 5B and 5C, provides elevational views of exemplary brushes as they may be in use according hereto;

FIG. 6, which includes subpart FIGs. 6A, 6B, 6C, 6D, 6E and 6F, provides respective isometric individual part and/or exploded views of a brush assembly of an oral cleaning device like those in FIGs. 1-5;

FIG. 7, which includes subpart FIGs. 7A, 7B and 7C, provides respective cut-away isometric and elevational views of exemplary oral cleaning devices according hereto;

FIG. 8, which includes subpart FIGs. 8A, 8B and 8C, provides respective isometric views of exemplary interior components of a device according hereto;

FIG. 9, which includes subpart FIGs. 9A, 9B and 9C, provides respective isometric views of an oral cleaning device/system and/or accessories hereof;

FIG. 10 is a collection, which includes subpart FIGs. 10A, 10B, 10C and 10D, of elevation, plan and isometric views of alternative brush assemblies for use with an oral cleaning device/system also according hereto; and,

FIG. 11, which includes subpart FIGs. 11A and 11B, provides respective elevational views of exemplary alternative brushes according hereto.

## DETAILED DESCRIPTION

[0010] The present invention relates in various embodiments to the provision of a new and useful, substantially automated oral cleaning device including unique coactive assemblages of distinct sub-assemblies which will be described herein in some detail. More particularly, the present invention is directed to a plurality of elements which when considered as one or more ensembles, may provide comprehensive attainment and/or maintenance of oral cleanliness. Of these, there are several primary features; among which are a variety of brush heads and brush head arrangements.

[0011] Now in more detail, though first in a relative macroscopic view; as shown at least initially in FIGs. 1 and 2, an exemplary automated tooth and/or gum cleaning device **20** hereof generally includes a control handle or module **21** and one or more cleaning head arrangement(s), herein generally referred to in the initial embodiments as respective cleaning head assemblies **26** and/or **27**. These respective cleaning or brush head assemblies **26** and/or **27** are shown in these embodiments positioning respective brushes, e.g. brushes **26a**, **26b** (see FIG. 3, *et al.*) and the brush bristles **34**, **35** thereof in operative dispositions, typically in a multiple directional fashion as described further below. The control handle **21** may then also include one or more control assemblies **24** (see FIG. 2) within its structural housing **23** to provide for either securely holding the brushes or for moving or driving a brush action to and/or through the brush head assemblies **26**, **27** for cleaning and massaging of the user's teeth and gums. In use, the toothbrush assemblages **26**, **27** hereof may provide a totality of brushing, cleaning and massaging of the user's teeth and gums.

[0012] A handle **21** may then also include a connection configuration **25** which provides for connection of the one or more brush assemblies **26**, **27** to the control handle **21**. This connection may generally involve a shaft or shafts **22**, two shafts being shown here, namely, shaft **22a** in the relative top position, and shaft **22b** in the relative bottom position (see FIG. 2, *inter alia*), these shafts **22** stemming or emerging from the housing structure **23** of the handle **21**, and then connecting to the brush assemblies **26**, **27**. Further details of brush mounting to/on a handle support assembly are shown and described below in particular relation to FIG. 6. Also as described in further detail below, the brushes may be made to be

replaceable or interchangeable when and/or if desired and thus removably mountable on respective shaft(s) 22.

[0013] The action of the brushes or brush assemblies 26, 27 may be manually maneuvered or activated, or may more often and/or more generally be driven by a control assembly or assemblies 24, as by a motor (see motor 44 in FIG. 2) and/or a mechanical system (see system 45, FIG. 2). And, either of these actions may be delivered with either a relatively fixed disposition of the brush arms and/or brush heads relative to each other, or as is further described herein for the primary embodiments hereof, the brush arms and/or heads may be reciprocated in and out alternately and/or in opposition to each other (see FIG. 4B, *inter alia*). The brush heads may then reach the teeth and gums in a desirable fashion as shown in and described relative to FIGs. 4A, 4B and 4C to thereby brush away plaque and/or debris lodged in and/or between the teeth, and/or provide a vital massage of the gums, particularly adjacent the teeth. And as is further shown and described hereinbelow (see FIG. 7), such a motor 44 may be activated to provide movement to a mechanical system 45 which in turn provides movement, via the shafts 22, to the brush assemblies 26, 27. As mentioned above and as will be shown and described further below, the provision of reciprocatable linear movement into and out of the oral cavity proficiently cleans the teeth and/or gums and also provides for reaching the rear most teeth as well as all of those in between.

[0014] As initially shown in FIG. 1, but, also in more detail in FIG. 3 (cumulatively including each of FIGs. 3A, 3B, 3C, 3D and 3E), each device 20 may include one or more brush or other cleaning head assemblies, here shown as brush assemblies 26, 27, which each may include one or more brushes, here see the brushes 26a, 26b of a brush assembly 26 in FIG. 3, each such brush 26a, 26b having respective brush arms 28a, 28b and brush heads 30a, 30b. The brush heads, e.g., heads 30a, 30b, may then be disposed such that adjacent brushes or sets of bristles may be used simultaneously during a brushing action. Combining multiple sets of brushing actions may provide better simulation or replacement of interproximal brushing, flossing, and/or perio picking and/or using proxy brushes.

[0015] The brushes are in many embodiments, see e.g., brushes 26a, 26b, disposed such that the brush heads, e.g., heads 30a, 30b, are disposed in or have portions thereof predisposed in a preselected angular disposition to appropriately impact the teeth and gums,

the intersection thereof and/or any gaps therebetween at the desired location, height, and width thereof. As such, the heads **30a**, **30b** may have respective head portions, namely, side portions **36a**, and crown portions **36b**. These brushes **26a**, **26b** can then contact the teeth from one or all sides of an array of teeth **50**, see e.g. the outside or cheek or bucal side **51** toward the other side, e.g., the inside and/or tongue or lingual side **52** of an array of teeth **50** and/or the crown or occlusial side **550** as shown for example in FIG. 4A, 4B and 4C.

[0016] The side portions **36a** and crown portions **36b** of the heads **30a**, **30b** may thus be disposed to have the bristles **34**, **35** disposed in an angular disposition, see angle  $\theta$  in FIG. 4A which may thereby provide a desirable cleaning action on the respective side surfaces of the teeth with which the tips of the bristles **34**, **35** may more effectively come into contact. As shown in FIG. 4A, the bristles **34**, **35** are shown angled downward to provide a potentially desirable impact of the bristles **34**, **35** with the gum line intersection of respective gums **58**, **59** with a tooth **56**. This may include an angle  $\theta$  at approximately a 45 degree angle (plus or minus) for the side bristles in accordance with the American Dental Association (ADA) recommended Bass or modified Bass technique, moreover, also according to this technique, a quantity of bristles may be disposed on or impact with the teeth (as for example approximately one-half in some embodiments) and another quantity of bristles on or in contact with the gums (in some cases as much as one-half the bristles). The crown bristles shown in FIGs. 3D, 3E and 4A may also be angularly disposed, though perhaps not at the approximate 45 degrees as those on the side (rather, more like a larger angle relative to the horizontal or smaller relative to the vertical orientation shown in the drawings).

[0017] It may also be desirable to provide an interaction of long bristles **34** of brushes such as brushes **26a**, **26b** particularly so as to substantially completely impact the deeper areas of teeth and between teeth, while having shorter brushes **35** impact the less deep, more prominent portions of teeth. For example, the long crown bristles **34** of adjacent brushes **26a**, **26b** may cover the interior depressed portion of the chewing or occlusial surface of the tooth, see e.g., tooth **56** in FIG. 4A, and the shorter crown bristles **35** (see FIGs. 3D and 3E) may impact the less deep extended tooth edges. Note the shorter bristles **35** may also be at a discrete angle, e.g. angle  $\alpha$  in Fig. 3E, less pronounced than that of the longer crown bristles **34** (crown bristles **34** e.g., preferably, at something like about 5 to 20 degrees from the vertical, with the crown bristles **35** being less, from about 0 to 10). Here an angle  $\alpha$  of about



14 or 15 degrees is shown. The shorter crown bristles **35** may thus be intended to impact and clean the higher, non-depressed, outer surfaces of the tooth. Moreover, it may be that the angle of the bristles on the crown portion **36b** of the respective brush head **30a**, **30b** may be different, more or less than that of the side portion **36a** bristles. Any combination of alternative angular dispositions may be used with the brushes of the present invention.

[0018] Other views of bristle dispositions are also shown, particularly of the side bristles **34**, **35** in the isometric views of FIGs. 3A, 3B and 3C, as well as in the respective cross-sectional elevation and plan depictions of FIGS. 4B and 4C (as taken along respective lines 4B—4B and 4C—4C of FIG. 4A). Moreover, these uneven bristles, i.e. long bristles **34** and short bristles **35**, as shown in FIGs. 3 and 4, provide bristle tip coverage of the uneven side surfaces of the tooth. For example, see the respective long and short bristles **34**, **35** on the uneven side surfaces of FIG. 4A and on the uneven side surfaces of FIG. 4C. As indicated above, and as shown in FIG. 4A, these bristles may even be angled on the otherwise relatively flat crown or chewing surface of the tooth to get full coverage of the tooth surface.

[0019] In the use of angled uneven length bristles **34**, **35**, the bristles may first be brought into contact with the tooth, then movement of the brush and thus also of the bristles, thereby brings the different length bristles into contact with the various uneven portions of the tooth surface, at various points the long bristles are brought into contact with deeper surfaces or interproximal areas between teeth or between a tooth and gum, and the short bristles also at times being brought into contact with the less deep, more prominent surfaces, the bristle tips in both cases being brought to full, non-interfered-with usage on the respective surfaces of the teeth, the bristle tips rather than the respective sides of the bristles. The angled disposition assists by substantially simultaneously directing the bristle tips toward the surface-to-be-cleaned and resisting bending of the bristle which would lead to the bristle side coming into contact with the tooth surface rather than the bristle tip.

[0020] Also directed to a maximal bristle cleaning activity may be an option of flexible, resilient brush arms, e.g., arms **28a**, **28b**, **29a** and/or **29b**, which can contribute to the preferred maintenance of the tips of the long and short bristles **34**, **35** in contact with the respective deeper and shallower tooth portions by alternately flexing outwardly during an encounter with a wider tooth or shallower oral feature and then upon encountering a deeper

or narrower feature, flexing or resiling inwardly to reach inwardly toward the deeper surfaces and/or the narrower teeth. This may be a part of providing for disposing the brushes in a preselected optimal brushing position. And, even the trim of the bristles may contribute to this maintenance of a desired bristle angle. As such, the trim at the tips of the bristles may be angled to be parallel to the tooth surfaces (see each of the views of FIG. 3). Moreover, the short and long trim of the bristles, which as otherwise described herein is primarily directed to reaching all the uneven surfaces of the teeth, including the interproximal areas, may also contribute to maximal cleaning because if all bristles were the same length, then upon reaching a raised area, the bristles would be deflected to present the sides of the bristles against the surfaces of the teeth and the sides of the bristles are not as capable of cleaning as the tips. Thus the bristle tips, as opposed to the bristle sides, are preferred to remain on or in contact with the enamel, with the long bristles also being adapted to reach into the interproximal areas without interference or with minimal interference or obstruction of the shorter bristles by long bristle sides on enamel surface. Note, long toothbrush heads, and/or overly voluminous bristle packing on a head can also yield problems like this, where rather less bristles may be better because the interference from adjacent bristles may be minimized. Rather accurate positioning (often very or ultra accurate positioning) of bristles is favored in the present implementations as opposed to the provision of an overabundance of bristles (such as is provided in some prior art brushes in an attempt or aspiration for hopefully some or any bristle(s) to hit the mark).

**[0021]** In some embodiments, in order to effectively substantially eliminate human error, the present brushes may provide a relative "self-positioning" of the brush arms, brush heads and bristles relative to the teeth and gums. Self-positioning may involve disposition relative to an oral feature such as a tooth or teeth and gums, and/or may involve in and out positioning as well as swiveling heads. The in and out positioning may primarily be a result of resilient brush arms which allow for spreading of the heads away from each other when encountering a wide tooth and resiling back inwardly toward their original position when narrower surfaces are encountered. The heads may also have resilient characteristics, e.g. of the side relative to the crown and vice versa. The resilient arms and/or heads may thus provide for biting into the combination of brush heads, the resilience providing for applying substantially continuous force for the brush heads to continually close in on or appropriately squeeze toward the teeth large or small, spreading as necessary for the larger teeth. Note, the

resiliency of the arms and/or heads may be selected so as to provide or apply a desirable, light yet operative pressure in the direction of bristles (maintaining the desirable angle, e.g. 45 degrees for the side bristles), not an overly aggressive or damaging force on the teeth and/or gums. Spreading is shown in FIG. 5A where a pair of brush heads **30a**, **30b** are shown as they might move outwardly (arrow **30c**), downwardly (arrow **30d**) or a combination of both (arrow **30e**). Note also, this self-positioning particularly with resilient arms and/or heads may allow for smaller brushes to be used, where the user bites down and thereby moves the arms and gets a better fit around the tooth (a smaller brush perhaps also/alternatively being desirable due to the reduction of bristle volume and thus reduced bristle interference to maximize bristle tip effectiveness).

**[0022]** A swiveling positioning may include such resiliency, allowing relatively independent twisting or rotation of one or the other or both of the arms upon encountering an obstruction. This is shown in FIG. 5B (rotational arrows **30f** and **30g**). Moreover, as described in further detail below, a swivel positioning may include the swivel of the whole head assembly right and/or left, and if two heads are used then the swivel may be of both heads substantially simultaneously, see clockwise rotation/swivel **30h** in FIG. 5C. Rotation is available for each of the head assemblies **26**, **27** about the respective shafts **22a**, **22b** on and to which the assemblies are mounted. Self positioning of these sorts may thus provide for easily and substantially automatically obtaining and maintaining the Bass position for teeth and for simplifying use in manipulation of the handle **21** for the human user and reducing or eliminating human error.

**[0023]** In use with two or four wrap-around brushes, such as one or as shown, two brushes in the top brush assembly **26** for the top teeth and/or one or two in the bottom brush assembly **27** for the bottom teeth, the user may simply bite into the brushing heads **26**, **27**, and self-positioning may be substantially automatic as the brushes position themselves or are otherwise positioned to substantially correctly contact tooth and gum surfaces (see FIGs. 4 and 5), any deviation accounted for by the resilient arms and/or the swiveling heads (see FIG. 5, e.g.). Thus, the brushes can achieve the ADA recommended Bass technique placement of bristles on teeth and gums, with the side contacts being at approximately a 45 degree angle (see FIG. 4A) or otherwise as may be desired. Each brush unit **26**, **27**, e.g., may have user specific dimensions, or may, due to the self-positioning described here, be fit for use in any

user's mouth for bristle contact of every to-be-cleaned surface of the user's teeth and gums and may provide interproximal, gingival and/or sub-gingival contact while assuring that the brushing action does not include an overly aggressive bristle force. Such self-positioning may be achieved substantially automatically with or without the user's knowledge, understanding or active participation.

**[0024]** Another part of the ADA Bass techniques recommendation is to reciprocate the brushes in short/quick, back and forth strokes while applying light pressure in the direction of bristles. Accordingly, the device **20** hereof can, and in many preferred embodiments will be adapted to provide a defined stroke that imparts an alternating brushing, as shown in FIG. 4B, for example, with a first stroke **53** in a first direction with a return in the opposite direction, and preferably here, one brush assembly, e.g., assembly **26** moving in the first direction **53** while a second brush head, e.g., assembly **27** is moving with a second stroke **54** in the other direction. The alternating stroke (out-to-in of one assembly simultaneously with in-to-out of the other assembly) is desirable for a variety of reasons, these reasons and exemplar sub-assemblies adapted to provide such strokes are described further below. It has been found that approximately 750-850 strokes per minute may provide the most effective results. Such speeds can be highly desirable, particularly as the strokes provide enough time for the bristles and particularly the bristle tips to react resiliently to move from one location to another and then have their bristle tips strike at debris trapped in a space, e.g., interproximal space **55** between the teeth, see e.g., teeth **56**, **57** (FIGs. 4B and 4C) which debris might then be trapped at or near the mid point and thereby loosen the debris more efficiently with a back and forth action so that the debris may be cleared therefrom. Slower speeds such as these (750-850 strokes per minute as opposed to 3 to 30 thousand (3-30k) strokes per minute of some conventional power brushes, e.g., so-called sonic brushes) are also more gentle, providing massage-like contact as opposed to dental drill-like, high-impact speeds.

**[0025]** Note also, in some embodiments, it may further be desirable to optionally though not necessarily include use of a dentifrice, tooth paste, flavor concentrate etc. To do this, the dentifrice may be delivered with, i.e., added to the brush or brush bristles in substantially conventional fashion and thus move with the brushes into the user's mouth and thereby be applied to the teeth and/or gums.

[0026] The respective brush assemblies **26**, **27** introduced above, may be unitary appliances, or may as shown in FIG. 6, be respective assemblies of one or more brushes, as for example the brushes **26a** and **26b** of FIG. 6 (see the individually-depicted brush **26b** of FIG. 6A and the respective combinations of brushes **26a** and **26b** of FIGs. 6B and 6C). Each of these brushes may in turn, also as shown and described above, each include arms **28a**, **28b** and heads **30a**, **30b**. Note, as identified in FIG. 6A, it may be desirable to include a relief, reduction and/or other curvature feature **38** in the arm(s) **28** to avoid undesirable impact of an arm **28** on/with the teeth in use. The heads **30a**, **30b** may also have respective head portions **36a**, **36b** (side, crown) (see also FIG. 3) with respective drill holes **37a**, **37b** (side, crown) to receive respective tufts **32a**, **32b** (side, crown) of bristles **34**, **35** (tufts **32a**, **32b** shown and identified in FIGs. 3B and 3C).

[0027] The respective brush assemblies **26**, **27** may also include respective brush bases **40** (see the assembled base **40** in FIG. 3A as well as the parted components of bases **40** in FIGs. 6B and 6C) for connection of the respective brushes together, and/or for connection of the brush assemblies to the control handle **21** and/or shafts **22**. The bases **40** may be initially separate devices or may as shown in FIG. 6 be separate portions **40a**, **40b** and **40c** formed as separate parts, portions **40a** and **40b** formed as integral parts of the respective brushes **26a** and **26b** and portion **40c** as a separate base piece. A variety of connection features **41** (e.g., posts and/or receiving holes therefor) may be included within the various portions **40a**, **40b** and **40c** to provide for the connection of the portions **40a**, **40b** and **40c** together. These portions may then be connected by snap fit, snug fit, friction fit or welded, e.g. sonically-welded, or glued or otherwise adhesively or cohesively or otherwise put and held together.

[0028] As shown in FIGs. 6C, 6D and 6E, a push-button device **42** may be included within the base **40** within its own slot **141** defined in one or more of the base portions **40a**, **40b** and **40c**. The push button **42** may preferably be spring-loaded counter the release direction, as by a spring **43** (shown schematically in FIG. 6F) adapted to be disposed in a spring feature **143** in the base **40**. The push button device **42** may have a push button surface **142a** to be disposed outside the base **40** and connected hereto, an internal structure **142c** with a cutout feature or ring **142b** here shown as a sort of elliptical cutout. As shown in FIG.6F, the push button device **42** is engagable with the quill end **122** of a shaft **22**, e.g. shaft **22a** (see

FIGs. 7A and 7B). The quill end **122** may have a slot or notch **123** with inner and outer diameters **123id** and **123od** (FIG. 6F) which together define the slot. Engagement as shown in FIG. 6F may then be had when the edge of the cutout feature **142b** clips into the slot **123**, and the spring **43** resiles back in the direction **144** under its spring force.

[0029] Disengagement of the quill end slot **123** from the cutout feature **142b** may be effected by pushing on the push-button surface **142a** in the direction **145** against the bias of the spring **43** which then allows for the outer diameter **123od** to enter and move through the cutout feature **142b** thereby allowing for removal of housing **40** and brush assembly **26** (or **27**) from the shaft **22**. Opposite engagement may be had by pushing the housing **40** onto the shaft **22** such that the quill end thereof enters the cutout feature **142b** and the ramp surface **122r** of the quill end engages the cutout feature and causes movement thereof against the bias of and compressing or otherwise deforming the spring **43** as the edge of the cutout feature rides along the incline of the ramp until the slot **123** is reached at which point the spring **43** pushes back against the push-button device **42b** to engage the edge of the cutout feature with the slot as shown in FIG. 6F.

[0030] The tooth brush assemblies **26, 27** may thus be removably mountable on the shafts **22** and thereby replaceable if and/or as they may be spent, or the assemblies **26, 27** may be interchangeable so that each of a plurality of users may each also have his/her own brush heads for sanitary reasons. Alternative cleaning head assemblies (see FIG. 10, or others not shown) may be interchangeably used herewith as well. Or, different sizes may be made available (for plural or singular users), e.g., smaller brushes can provide a better fit around particular teeth, or for particular users, smaller brushes perhaps being more comfortable as well, and/or providing fewer bristles and thus reduce bristle interference.

[0031] Moving shafts for moving the cleaning heads **26, 27** will now be described. For example, in FIGS. 2 and 7 (including FIGs. 7A, 7B and 7C), are depictions of isometric cut-away views of alternative handles **21** of exemplary units **20** which each provide for moving one or more cleaning assemblies **26, 27** on respective shafts **22a, 22b** of a connection assembly **25**. More particularly, the structural shafts **22a, 22b** may be disposed in reciprocal motive disposition in and emanating from the control handle **21**. Note, the shafts **22a, 22b**

may be relatively integral or contiguous with or otherwise as shown and described above, may be connectable with brush assemblies **26, 27**.

[0032] Inside the control handle **21** may be one or more control assemblies **24** which may include conventional or unconventional reciprocation hardware. As a first example, a direct current (DC) motor **44** may be included to provide primary power to reciprocate the brush head assemblies **26, 27**. The motor **44** may activate a mechanical system **45** such as a system of gears, to ultimately move the cleaning head assemblies **26, 27**. The system **45** may be a double reciprocal/opposing movement like that described and shown in FIGs. 2 and 7 which may include mechanisms like a crown gear **208** connected by a shaft to a reduction spur gear **209** which communicates in gear meshing relationship with a double cam gear **203** (see FIGs. 7A, 7B and 7C). The DC motor **44** is adapted to directly turn a pinion gear **210** which in turn, turns the crown gear **208** and thence gear **209** is turned and turns the double cam gear **203**. The gear **203** has respective cams **204, 205** one each on opposite sides of the gear **203** (see FIGs. 7 and 8 (8A, 8B and 8C)). The upper cam **204**, the double cam gear **203**, and lower cam **205** may be separate parts or may all be combined as one piece. Structural shafts/arms **22a** and **22b** may be attached to cam followers **206, 207** (FIG. 8). The double-cam big gear **203** which may thus by contact move the two cam followers **206, 207** to move in and out the shafts **22a, 22b** relative to the power handle **21**. Thus, this causes the structural shafts **22a, 22b** to reciprocate in opposing directions and thereby provide for alternating dispositions of the heads **26, 27**, the positions and directions being substantially and reversibly in opposition such that at one moment, the heads are as shown, and then they may be reciprocated such that they switch relative positions inside the mouth. FIGs. 7A and 7B show one position where the shaft **22a** is further retracted within the handle **21** while the other shaft **22b** is extended. A switched position is shown in FIGs. 1 and 2 where the upper shaft **22a** is extended and the other shaft **22b** is retracted. The shafts **22** thereby further provide this reciprocable linear movement to the brush head assemblies **26, 27** to alternately move into and out of the oral cavity in order to desirably clean the teeth and/or gums.

[0033] Note, the two top heads **30a, 30b** on the brush assembly **26** may as shown preferably be reciprocated together and the other, lower two heads **31a, 31b** of the brush assembly **27** may be reciprocated together in opposed relationship to the upper heads. In many cases with devices **20** it will be preferable to provide such alternate reciprocal moving

part embodiments having respective opposing parts moving contrary to each other to provide balance to the overall device. In any two opposed brush orientations, the opposing brushes may be moving substantially simultaneously in opposite directions, one out while the other is moving in and vice versa. Reciprocation of top and bottom and reciprocation in opposite directions provides substantially simultaneous action and reaction in and out, and this force action and reaction cancels each other out so that net motive force on the handle **21** is substantially zero and the handle **21** thereby remains stationary. The mechanical force counterforce, i.e., the force(s) tending to push the brush heads further in, or out of the mouth simultaneously provide at least a reduction of the overall forces felt by the user who may then be able to operate the device simply by and through the use of a simple/minimal grasp of the handle **21** with the thumb and forefinger. This overall action/reaction may also provide a further advantage in the self-positioning described above, overcoming the reciprocal brushing action to allow the brush head and bristle design to achieve and maintain the desirable self-position (FIGs. 4 and 5) unforced away therefrom by the motor driven reciprocation. Also in these and/or other two or four (or more) brush embodiments, though at least two such brushes may move together, it may remain preferable to have contrary alternating movements whether for relative top and bottom movements or for contrary side versus side movements.

[0034] As mentioned above, the device **20** can provide alternating brushing, with, as shown in FIG. 4B, a first stroke **53** in a first direction with a second stroke **54** in the other direction. And, approximately 750-850 strokes per minute may provide the most effective results. Such alternating stroke speeds can be highly desirable as the strokes may have enough time for the bristles to react resiliently to move from one location to another and then strike at debris trapped in a space, e.g., interproximal space **55** between the teeth, see e.g., teeth **56**, **57** (FIGs. 4B and 4C) which debris might then be trapped at or near the mid point and thereby loosen the debris more efficiently with a back and forth action so that the debris may be cleared therefrom. Slower speeds such as these (750-850 strokes per minute as opposed to 3 to 30 thousand (3-30k) strokes per minute of some conventional power brushes, e.g., so-called sonic brushes) are also more gentle, providing massage-like contact as opposed to dental drill-like, high-impact speeds. Note, many other conventional power brushes boast high speeds, often spinning actions of 4,000 rpm and more, speeds that can create a feeling of discomfort. The slower speeds preferred here, on the other hand, rely on accurate bristle positioning to obtain effectiveness, and as a result, the brushes can reciprocate at a fraction of



the speed of other products, resulting in user enjoyment of a comfortable massage with every use. Note, multiple or multi-speed options may alternatively be made available in these or other ranges of strokes per minute. In many cases, one speed is acceptable, but optionally one or more slower speeds can be offered particularly for beginners to become accustomed to the action. Faster speeds may also be offered.

[0035] An assembly such as this may be adequate for twin cooperative goals of efficaciously brushing the occlusal and lingual-buccal surfaces of the teeth and gums (including gaps between such surfaces and/or between the teeth and gums) while also simultaneously brushing the aforementioned surfaces and also the underlying gums. An aspect hereof may thus be the provision of an improved powered toothbrush for simultaneously efficaciously brushing the occlusal and the lingual buccal surfaces including any gaps therebetween while simultaneously beneficially brushing the teeth surfaces and also the underlying teeth/gums, the latter benefit representing therapeutical prevention of periodontal problems.

[0036] Note, shown in FIG. 9 is a schematic representation of a system **20** including a brush control module **21** with a power unit **46** and a power cable or **47** connected therebetween for plugging into a wall socket, for an example. The control handle **21** may either be hardwire connected or may more preferably be rechargeable (e.g., rechargeable batteries or induction charging mechanism(s), not shown) and thus operated without a power cable **47** and external power source **46**. A remote charger or induction charging unit would then be used, and in such a case the representation in FIG. 9A could be indicative of the disconnectable connection for recharging. In some embodiments on this scale, a recharger may provide a multiplicity of operations, as for example up to 50 times, or up to a month, e.g.

[0037] Other repowering connections may also be had, as for example, including non-rechargeable, but replaceable batteries or where the recharger is built into the handle **21** or involves a table top recharging stand **48** for placement of the handle **21** therein as illustrated generally in one exemplar implementation of FIG. 9B, such being adapted to rest on counter-top or other surfaces. Also shown in FIG. 9B are several brush cases **49a** for holding, temporarily, brush assemblies **26**, **27** to be connected to a handle **21**. A further alternative handle case **49b** (top not shown) is shown in FIG. 9C, in which a handle **21** may be made to

rest or otherwise be disposed in an storage location, as for example, horizontally on the counter, in a drawer or on a shelf; or, which may be adapted for portability, i.e., to carry the handle **21** thus making the device travel friendly (particularly with such devices having long re-charge options (e.g., 50 uses or a month's amount of uses)). Each of the cases **49a**, **49b** may preferably include air and/or drainage holes to allow breathing/drying and/or drainage of water away after use.

[0038] An alternative embodiment, see FIG. 10 (including FIGs. 10A, 10B, 10C and 10D), may include alternative sub-assemblies **226**, **227** including triple toothbrushes, see e.g., brushes **226a**, **226b**, **226c** and **227a**, **227b** and **227c**. Exemplary tripartite or other brush assemblies for use in alternative embodiments like those shown here may also alternatively be like those disclosed in co-pending U.S. patent application Ser. No. 10/357564 filed February 5, 2003, and in PCT application No. US20030357564, Publication No. WO03101365 (A1), both by at least one of the same inventor(s) as the present case. The disclosures of those applications are hereby incorporated herein by reference as if fully set forth here. More particularly, in this first alternative example, shown in FIGS. 10A through 10D, a brush device **20** may include a handle **21** as above, with one or more forwardly positioned brushing assembly(ies) **226**, **227** for brushing lingual and bucal surfaces and occlusal surfaces of a row of teeth. Brushes like these tripartite brush assemblies **226**, **227** can be used for brushing insides, outsides and topsides or crowns of the teeth substantially simultaneously, and may also be used to position the brushes in operative position and guide the brushes throughout the oral cavity for efficient usage. In this and various of the other toothbrush examples usable herein/herewith, as for example with the currently described tripartite brushheads **226**, **227**, these may be adapted to receive one or more teeth securely therein, and thereby position the device **20** such that the brushes **226a**, **226b**, **226c** and **227a**, **227b** and **227c** may be very advantageously aimed at the teeth and/or gums in strategic position to provide maximal cleaning. An angle of such cleaning may be such as to point the bristles at the gum line as suggested by various drawing figures herein, as in the particular examples of FIGs. 10A and 10C.

[0039] The brush combinations are optional, and/or interchangeable. A tripartite assembly **226** for example could include optionally one or more laterally spaced heads **226a**, **226b** and could further include a crown brush **226c**. Similarly, a lower tripartite assembly

**227** could include a crown brush **227c** (this could be a sole brush, see e.g., brush 327 in FIG. 11, described below), and/or may optionally include lateral heads **227a**, **227b**. In such embodiments, the brush head assemblies could provide secure top to bottom and/or lateral, side to side positioning of the cleaning assembly(ies) **226** and/or **227** inside a user's mouth. All the user would need to do is bite down into the brush head assembly(ies), and thereby have the brushes adequately and potentially very accurately positioned for maximal cleaning. Moreover, here also, in order to effectively eliminate human error, these tripartite brushes may also "self-position" relative to the teeth and gums. As such, the six (6) brushes in the Fig. 10 implementation are pre-positioned to correctly contact tooth and gum surfaces. The user simply bites into the brushing head, and self-positioning is automatically provided in accordance with the ADA recommended Bass technique, placing a desirable proportion of bristles (e.g., one half ( $\frac{1}{2}$ )) on the teeth and another proportion of bristle tips (e.g., another one half ( $\frac{1}{2}$ )) on the gums at approximately a 45 degree angle. Note, positioning the brushes properly may be generically referred to using a guide means, here the arrangement of one or more brushes, which themselves lock around the teeth and correctly position the bristles. And, as above, the position of the brushes **226a-c** and/or **227a-c** here may also use/rely on the resilient spreading and/or squeezing movement of the respective heads **230a**, **230b**, **230c**, **231a**, **231b** and/or **231c**, that are connected by six respective resilient arms **228a**, **228b**, **228c**, **229a**, **229b** and **229c** to respective bases **240**, and are connected by shafts/extensions **22a**, **22b** to handle **21** (see Fig. 10B, e.g.).

[0040] Furthermore, although uneven bristle groups **234**, **235** are not necessarily shown in FIGs. 10A – 10C, such groups are indicated in FIG. 10D to highlight the optionality hereof as they may, even with tripartite brushes, provide desirable bristle tip coverage of the uneven surfaces of the tooth, as for example on the uneven chewing surface and the uneven side surfaces of FIG. 4. Note also for this or any uneven bristle embodiment (described here or otherwise), the building or manufacture of short and long bristles in one brush can be a more complicated process than many conventional brush processes, by including multiple steps, as in: planting a first set of short bristles, then, trimming those short bristles to the desired point, and then planting the long bristles and finally trimming the long bristles to size.

[0041] The respective brush head assembly(ies) **226**, **227** can also as described above, be detachably attached to the end of the respective structural brush shafts **22a**, **22b**.

Detachability may be effected through use of depressible button **242** which can release a spring catch (not shown here), and the respective brush head **226** (and/or **227**) can then be removed or pulled therefrom. A similar disposition and action may be had with the brushes (if so desired) and the corresponding structural shafts. In some embodiments, the brush head(s) may be installed onto corresponding shafts, until they go on to a point at which the button "snaps" and locks the brush head in relation to the respective structural shaft.

[0042] And, yet again as above, the brushes may be reciprocated in short strokes in accordance with ADA recommended Bass technique, brushing with a short/quick back and forth action(s). As such, the control handle **21** may in many embodiments be provided with powering means (see e.g., FIGs. 7, 8 and 9) for providing reciprocating longitudinal movement in alternating synchronization of the tripartite brushing head assemblies **226**, **227**. The upper brush head and lower brush head may preferably be made to move in opposite directions, i.e., when the upper brush head **226** is moving inward, the lower brush head **227** is moving outward. This is desirable in many embodiments because when a user bites into the upper and lower brush heads at the same time, the opposing reciprocatable movement can provide a "balance"; e.g., balance of forces, so that the power handle does not tend to move in and out, or otherwise, as a result of the forced movement and/or contact with both the upper and lower brush head simultaneously. The user then may easily hold the device **20** without manual exertion, dexterity or otherwise other than to position the device relative to the mouth.

[0043] In general, brush head assemblies could include one or more brush heads. In one further alternative, for example, a singular brush head (not directly shown) could be used. Alternatively or in addition thereto, one or more or an arrangement of brush heads could be disposed for brushing the sides of the teeth and/or the crowns of the teeth. Examples of such arrangements include those brush assemblies **326** and/or **327** shown in FIG. 11. In this way, either a combination of lateral brushes **326a**, **326b** can be used on the top teeth (or bottom) while an independent brush **327** may be used on the bottom (or top) teeth. Or one of these brushes **326**, **327** or other combinations of brushes could be used independently of the other set of brushes to provide controlled brushing action for top and bottom teeth but on only one side (top, bottom, inside or outside) or on the crowns/chewing surfaces, as desired at a time. Alternation may then be available from a first side to the other side, or top to bottom, etc. as

desired. As introduced above, positioning the brushes properly may be provided by a guide means which might be provided by the one or more brushes themselves wherein these lock around the teeth through the resiliency of the brush heads and/or arms to correctly position the bristles at the appropriate angles and locations adjacent the teeth and/or gums. Such action may here as well be provided by or receive assistance from a set of resilient arms, e.g., arms **328a**, **328b** and/or **329** spreading or squeezing a set of one or more brush heads, e.g., brushes **330a** or **330b**, or **331**. Also as before, the opposing brushes can be moved in an alternating brushing action to provide a desirable force balance.

[0044] In another, single brush alternative, the single brush may have at least one set of side bristles together with a set of crown bristles, the single brush having a resilient head and/or arm to allow for self-positioning of the respective bristles relative to an oral cavity feature such as a tooth, gum or intersection therebetween. Such a single brush may moreover have two opposing side sets of bristles with or without crown bristles and may have internal head and/or arm resiliency to provide for self-positioning of the respective bristles relative to an oral cavity feature.

[0045] From the foregoing, it is readily apparent that new and useful embodiments of the present invention have been herein described and illustrated which fulfill numerous desiderata in remarkably unexpected fashions. An assembly such as any of these described herein may be adequate for twin cooperative goals of efficaciously brushing the occlusal and lingual-buccal surfaces, including gaps therebetween, while also simultaneously brushing the aforementioned surfaces and also the underlying teeth and gums thereby providing therapeutical prevention and/or treatment of periodontal problems. It is, of course, understood that such modifications, alterations and adaptations as may readily occur to the artisan confronted with this disclosure are intended within the spirit of this disclosure which is limited only by the scope of the claims appended hereto.

## CLAIMS

What is claimed is:

1. An oral cleansing device comprising:
  - a handle including:
    - a housing structure;
    - at least one control assembly disposed within the housing structure; and,
    - a connection configuration stemming from the handle housing structure; and,
    - at least one brush assembly connected to the connection configuration of the handle;
  - whereby the at least one brush assembly includes first and second brushes, the first and second brushes each including respective first and second resilient arms adapted to be connected to the connection configuration, the first and second resilient arms each respectively having first and second brush heads connected thereto;
  - whereby the first and second brushes are operatively disposed such that the first and second brush heads are disposed in generally opposing relationship to each other;
  - whereby the first and second brush heads each have respective crown portions and respective side portions.
2. A device according to claim 1, in which the respective crown portions are occlusal brush head portions and the respective side portions are respective lingual and bucal brush head portions.
3. A device according to claim 1, in which the respective crown portions are occlusal brush head portions and the respective side portions are alternately lingual and bucal brush head portions.
4. A device according to claim 1, in which the at least one brush assembly is adapted to be self-positioning.
5. A device according to claim 1, in which the at least one brush assembly is adapted to be self-positioning to surround at least one oral cavity feature.

6. A device according to claim 5, in which the at least one oral cavity feature is one or any combination of a tooth, a plurality of teeth, a gum or a plurality of gums, or one or more gum line intersections of a tooth or teeth and gums.
7. A device according to claim 1, in which the at least one brush assembly is adapted to be self-positioning to surround at least one oral cavity feature about the occlusal, bucal and lingual surfaces thereof.
8. A device according to claim 1, in which the at least one brush assembly is adapted to be self-positioning; whereby the resilient arms are adapted to resiliently move the brush heads to surround at least one oral cavity feature.
9. A device according to claim 8, in which the at least one oral cavity feature is one or any combination of a tooth, a plurality of teeth, a gum or a plurality of gums, or one or more gum line intersections of a tooth or teeth and gums.
10. A device according to claim 8, whereby the resilient arms are adapted to either or both resiliently spread the brush heads to surround at least one oral cavity feature or resiliently squeeze the brush heads to surround at least one oral cavity feature.
11. A device according to claim 8, whereby the resilient arms are adapted to resiliently apply an operative pressure to the at least one oral cavity feature.
12. A device according to claim 1, in which the at least one brush assembly is adapted to be self-positioning; whereby the brush heads are resilient and are adapted to resiliently move to surround at least one oral cavity feature.
13. A device according to claim 1, in which each of said first and second brush heads are disposed at a discrete angle relative to each other.
14. A device according to claim 1, in which each of said first and second brush heads disposed at a discrete angle relative to an oral cavity feature.

15. A device according to claim 14, in which said oral cavity feature is a gum line intersection of a tooth and gums.
16. A device according to claim 1, in which each of said first and second brush heads have bristles mounted therein.
17. A device according to claim 1, in which each of said first and second brush heads have bristles mounted therein, the bristles being disposed at a discrete angle relative to each other.
18. A device according to claim 1, in which each of said first and second brush heads have bristles mounted therein, the bristles being disposed at a discrete angle relative to an oral cavity feature.
19. A device according to claim 18, in which the at least one oral cavity feature is one or any combination of a tooth, a plurality of teeth, a gum or a plurality of gums, or one or more gum line intersections of a tooth or teeth and gums.
20. A device according to claim 1, in which each of said first and second brush heads have bristles mounted therein, the bristles being adapted to be self-positioning.
21. A device according to claim 1, in which each of said first and second brush heads have bristles mounted therein, the bristles being trimmed to be in parallel with the tooth surfaces with which the bristle tips are adapted to contact.
22. A device according to claim 1, in which each of said first and second brush heads have bristles mounted therein, wherein the first and second brush heads are adapted to be self-positioning to dispose the bristles in operative position.
23. A device according to claim 1, in which each of said first and second brush heads have bristles mounted therein, wherein the first and second brush heads are adapted to be self-positioning to dispose the bristle tips in operative position.



24. A device according to claim 1, in which each of said first and second brush heads have bristles mounted therein, wherein the first and second brush heads are adapted to be self-positioning to dispose the bristles in optimal operative position.
25. A device according to claim 1, in which each of said first and second brush heads have bristles mounted therein, whereby the bristles are disposed in discrete tufts.
26. A device according to claim 1, in which each of said first and second brush heads have bristles mounted therein, whereby the bristles are disposed in discrete tufts, the bristle tufts having discretely long and short sized bristles.
27. A device according to claim 1, in which each of said first and second brush heads have bristles mounted therein, whereby the bristles are disposed in discrete tufts, the bristle tufts being in alternately long and short sizes.
28. A device according to claim 1, in which each of said first and second brush heads have bristles mounted therein, the bristles having respective long and short sizes.
29. A device according to claim 1, in which each of said first and second brush heads have bristles mounted therein, the bristles having respective and alternately long and short sizes.
30. A device according to claim 1, in which each of said first and second brush heads have bristles mounted therein, whereby the bristles are disposed in discrete tufts, the bristle tufts being in alternately long and short sizes, the bristle tips being trimmed to be in parallel with the tooth surfaces the tips are adapted to contact.
31. A device according to claim 1, in which the at least one brush assembly is adapted to be self-positioning in the connection of the at least one brush assembly to the connection configuration of the handle.
32. A device according to claim 1, in which the at least one brush assembly is adapted to be self-positioning in the connection of the at least one brush assembly to the connection

configuration of the handle; whereby the connection of the at least one brush assembly to the connection configuration of the handle provides a swivel of the at least one brush assembly.

33. A device according to claim 1, in which the at least one brush assembly includes respective top and bottom brush assemblies connected to said handle.

34. A device according to claim 1, in which the at least one brush assembly includes respective top and bottom brush assemblies connected to said handle and in which the respective top and bottom brush assemblies are adapted to be self-positioning in the connection of the top and bottom brush assemblies to the connection configuration of the handle; whereby the connection of the top and bottom brush assemblies to the connection configuration of the handle provides a swivel of the top and bottom brush assemblies.

35. A device according to claim 1, in which the control assembly has structure adapted to hold the at least one brush assembly in fixed operative position.

36. A device according to claim 1, in which the control assembly is adapted to provide movement of the at least one brush assembly.

37. A device according to claim 1, in which the control assembly includes a mechanical gear assembly.

38. A device according to claim 1, in which the control assembly includes an electrical control system.

39. A device according to claim 1, in which the control assembly includes a motor.

40. A device according to claim 1, in which the at least one brush assembly includes respective top and bottom brush assemblies connected to said handle; and,  
in which the control assembly has structure adapted to hold the at least one brush assembly in fixed operative position relative to the handle.

41. A device according to claim 1, in which the at least one brush assembly includes respective top and bottom brush assemblies connected to said handle; and,  
in which the control assembly is adapted to provide movement of the at least one brush assembly.
42. A device according to claim 1, in which the at least one brush assembly includes respective top and bottom brush assemblies connected to said handle; and,  
in which the control assembly is adapted to provide movement of the respective top and bottom brush assemblies.
43. A device according to claim 1, in which the at least one brush assembly includes respective top and bottom brush assemblies connected to said handle; and,  
in which the control assembly is adapted to provide movement of the respective top and bottom brush assemblies in alternating manner.
44. A device according to claim 1, in which the at least one brush assembly includes respective top and bottom brush assemblies connected to said handle; and,  
in which the control assembly is adapted to provide movement of the respective top and bottom brush assemblies in simultaneous alternating manner.
45. A device according to claim 1, in which the at least one brush assembly includes respective top and bottom brush assemblies connected to said handle; and,  
in which the control assembly is adapted to provide movement of the respective top and bottom brush assemblies in simultaneous alternating manner to provide a force balance.
46. A device according to claim 1, in which the connection structure is a movable connection structure being connected with said at least one brush assembly; the movable connection structure being adapted to move the at least one brush assembly relative to the oral feature.
47. A device according to claim 1, in which the connection structure is a movable connection structure being connected with said at least one brush assembly; the movable connection structure being adapted to move the at least one brush assembly relative to the

oral feature; and in which the at least one control assembly is adapted to provide movement of the at least one brush assembly.

48. A device according to claim 1, in which said at least one brush assembly includes respective first and second brush assemblies and in which the connection structure includes first and second movable connection structures being connected with the respective first and second brush assemblies; the first and second movable connection structures being adapted to move the respective first and second brush assemblies relative to the oral feature.

49. A device according to claim 1, in which said at least one brush assembly includes respective first and second brush assemblies and in which the connection structure includes first and second movable connection structures being connected with the respective first and second brush assemblies; the first and second movable connection structures being adapted to move the respective first and second brush assemblies relative to the oral feature in simultaneous alternating manner to provide a force balance.

50. A device according to claim 1 wherein the at least one brush assembly includes a push-button catch element to detachably attach the at least one brush assembly to the movable connection structure.

51. An oral cleansing device comprising:

a handle including:

a housing structure;

at least one control assembly disposed within the housing structure; and,

a connection structure stemming from the handle housing structure; and,

at least one brush assembly connected to the connection structure of the handle;

whereby the at least one brush assembly includes at least one brush including at least one resilient arm adapted to be connected to the connection structure, the at least one resilient arm having a resilient brush head connected thereto, the at least one brush head having at least one first set of side bristles and one or both of an opposing set of side bristles and a set of crown bristles;

whereby the first set of side bristles and the one or both of the opposing set of side bristles and a set of crown bristles are operatively disposed such that the first and second brush heads are adapted to be self-positioning in relation to an oral feature.

52. A device according to claim 51, in which the respective crown portions are occlusal brush head portions and the respective side portions are respective lingual and bucal brush head portions.

53. A device according to claim 51, in which the respective crown portions are occlusal brush head portions and the respective side portions are alternately lingual and bucal brush head portions.

54. A device according to claim 51, wherein the oral feature is one or any combination of a tooth, a plurality of teeth, a gum or a plurality of gums, or one or more gum line intersections of a tooth or teeth and gums.

55. A device according to claim 51, in which the connection structure is a movable connection structure being connected with said at least one brush assembly; the movable connection structure being adapted to move the at least one brush assembly relative to the oral feature.

56. A device according to claim 51, in which the connection structure is a movable connection structure being connected with said at least one brush assembly; the movable connection structure being adapted to move the at least one brush assembly relative to the oral feature; and in which the at least one control assembly is adapted to provide movement of the at least one brush assembly.

57. A device according to claim 51, in which said at least one brush assembly includes respective first and second brush assemblies and in which the connection structure includes first and second movable connection structures being connected with the respective first and second brush assemblies; the first and second movable connection structures being adapted to move the respective first and second brush assemblies relative to the oral feature.

58. A device according to claim 51, in which said at least one brush assembly includes respective first and second brush assemblies and in which the connection structure includes first and second movable connection structures being connected with the respective first and second brush assemblies; the first and second movable connection structures being adapted to move the respective first and second brush assemblies relative to the oral feature in simultaneous alternating manner to provide a force balance.

59. An oral cleansing device comprising:

a handle including:

a housing structure;

at least one control assembly disposed within the housing structure; and,

a connection shaft assembly including at least upper and lower shafts

stemming from the housing structure; and,

at least one brush assembly adapted to be connected to the connection shaft assembly of the handle;

whereby the at least one control assembly includes a mechanical system to move the at least one brush assembly; the mechanical system including:

a crown gear connected by a gear shaft to a reduction spur gear

a double cam gear which communicates in gear meshing relationship with the reduction spur gear; the reduction spur gear being adapted to drive the double cam gear; the double cam gear having respective upper and lower cams, one each on opposite sides of the double cam gear;

upper and lower cam followers being disposed in operative contact with the respective upper and lower cams of the double cam gear; the double-cam gear by contact through the respective upper cam and lower cam, being adapted to move the two cam followers;

the upper and lower shafts being attached to the respective upper and lower cam followers, the upper and lower shafts thus being adapted to move with the respective upper and lower cam followers and thereby also move the at least one brush assembly therewith.

60. An oral cleansing device according to claim 59 wherein the at least one brush assembly includes upper and lower brush assemblies and the shafts reciprocate in and out and thereby provide for alternating reciprocation of the upper and lower brush assemblies.

61. An oral cleansing device according to claim 59 wherein the at least one brush assembly includes upper and lower brush assemblies and the shafts reciprocate in opposing directions and thereby provide for alternating reciprocation of the upper and lower brush assemblies.

62. An oral cleansing device according to claim 59 wherein the at least one brush assembly includes upper and lower brush assemblies and the shafts reciprocate in opposing directions and thereby provide for alternating reciprocation of the upper and lower brush assemblies, whereby the alternating reciprocation provides balance to the overall device.

63. An oral cleansing device according to claim 59 wherein the at least one brush assembly includes upper and lower brush assemblies and the upper and lower brush assemblies each include two heads and the shafts reciprocate and thereby provide for alternating reciprocations of the upper and lower brush assemblies.

64. An oral cleansing device according to claim 59 further including a motor, the motor adapted to provide primary power to reciprocate the at least one brush head assembly.

65. An oral cleansing device according to claim 59 further including a motor, the motor adapted to provide primary power to reciprocate the at least one brush head assembly; the motor having a pinion gear in communication with the crown gear; whereby the motor is adapted to directly turn the pinion gear which in turn, turns the crown gear which turns the reduction spur gear to turn the double cam gear.

66. An oral cleansing system comprising:  
an oral brush device having:  
a handle including:  
a housing structure;

a movable connection structure stemming from the handle housing structure; and,

at least one control assembly disposed within the housing structure; the at least one control assembly including a power-driven sub-assembly, the power-driven sub-assembly providing movement for the movable connection structure;

a power assembly; the power assembly being adapted to be connected to the power-driven sub-assembly of the at least one control assembly; and,

at least one brush assembly adapted to be detachably attachable to the movable connection structure of the handle;

whereby the at least one brush assembly includes at least one brush having at least one resilient arm adapted to be connected to the connection structure, the at least one resilient arm having a resilient brush head connected thereto, the at least one brush head having at least one first set of side bristles and at least one of an opposing set of side bristles and a set of crown bristles;

whereby the first set of side bristles and the one or both of the opposing set of side bristles and a set of crown bristles are operatively disposed such that the first and second brush heads are adapted to be self-positioning in relation to an oral feature.

67. A system according to claim 66 wherein the power assembly is an electrical assembly.

68. A system according to claim 66 wherein the power assembly is an electrical adaptor connected to the power-driven sub-assembly.

69. A system according to claim 66 wherein the power assembly includes one or more rechargeable batteries disposed within the handle and an electrical recharger assembly which is adapted to be disconnectably connected to the one or more rechargeable batteries.

70. A system according to claim 66 wherein the power-driven sub-assembly includes an electrical motor.

71. A system according to claim 66 wherein the power-driven sub-assembly includes an electrical motor connected to a mechanical gear system, the mechanical gear system being connected to the connection structure.



72. A system according to claim 66 wherein the at least one brush assembly includes a push-button catch element to detachably attach the at least one brush assembly to the movable connection structure.

73. A method for cleansing an oral cavity feature comprising:  
taking hold of the handle of a power-driven oral cleansing device having a brush head assembly connected by a movable connection structure to the handle;  
biting into the brush head assembly to surround the oral cavity feature with brush bristles;  
powering the power-driven oral cleansing device to move the connection structure and the brush head assembly with linear brushing strokes.

74. A method according to claim 73 wherein the oral feature is one or any combination of a tooth, a plurality of teeth, a gum or a plurality of gums, or one or more gum line intersections of a tooth or teeth and gums.

75. A method according to claim 73 whereby the brush head assembly includes at least one brush having at least one resilient arm adapted to be connected to the movable connection structure, the at least one resilient arm having a resilient brush head connected thereto, the at least one brush head having at least one first set of side bristles and at least one of an opposing set of side bristles and a set of crown bristles; and  
whereby the first set of side bristles and the one or both of the opposing set of side bristles and a set of crown bristles are operatively disposed such that the first and second brush heads are adapted to be self-positioning in relation to an oral feature.

76. A method according to claim 73 whereby the brush head assembly is adapted to be detachably attachable to the movable connection structure of the handle.

77. A method according to claim 73 in which the brush head assembly includes respective first and second brush assemblies and in which the connection structure includes first and second movable connection structures being connected with the respective first and second brush assemblies; the first and second movable connection structures being adapted to move

the respective first and second brush assemblies relative to the oral feature in simultaneous alternating manner to provide a force balance.

1/34

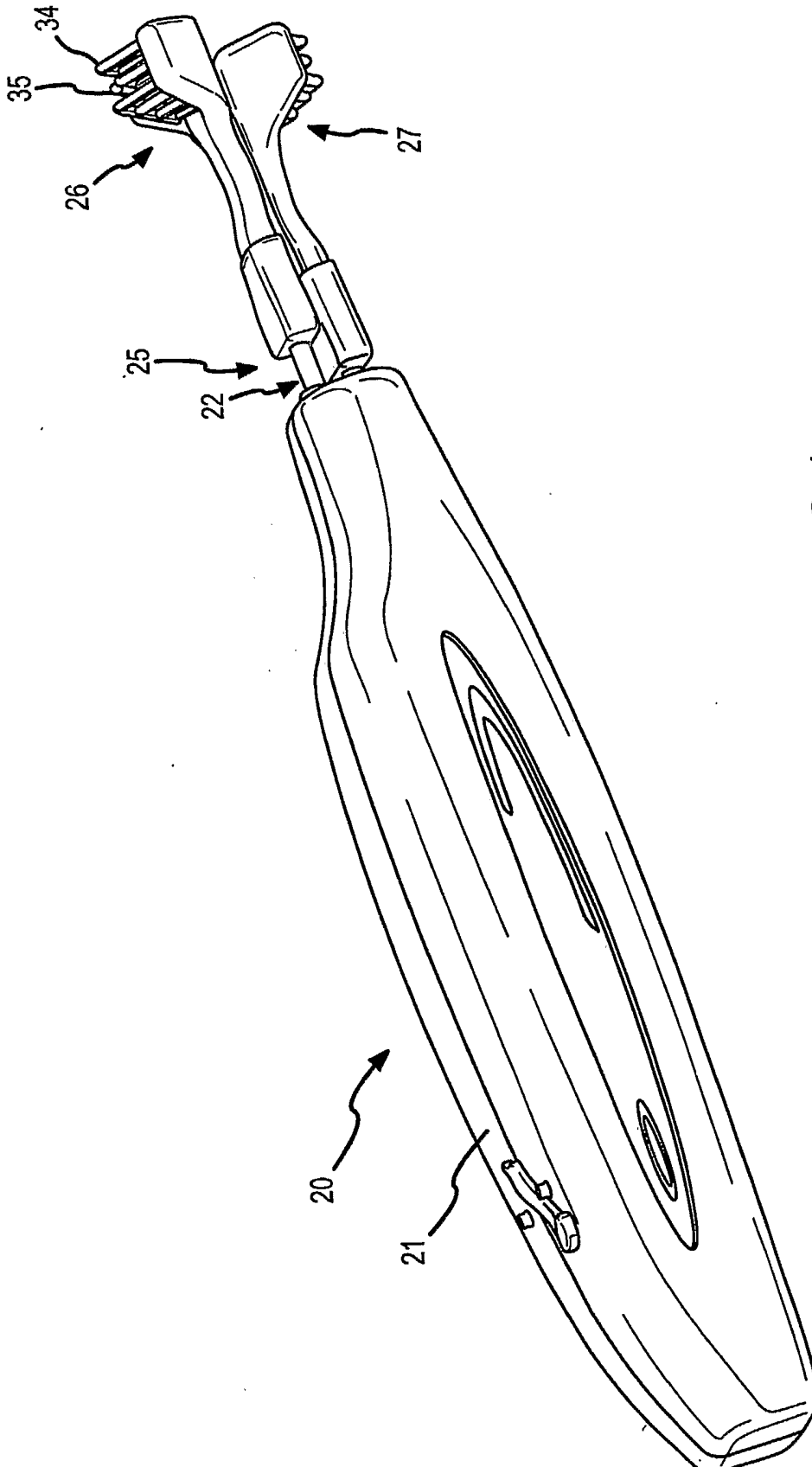

FIG.1

2/34

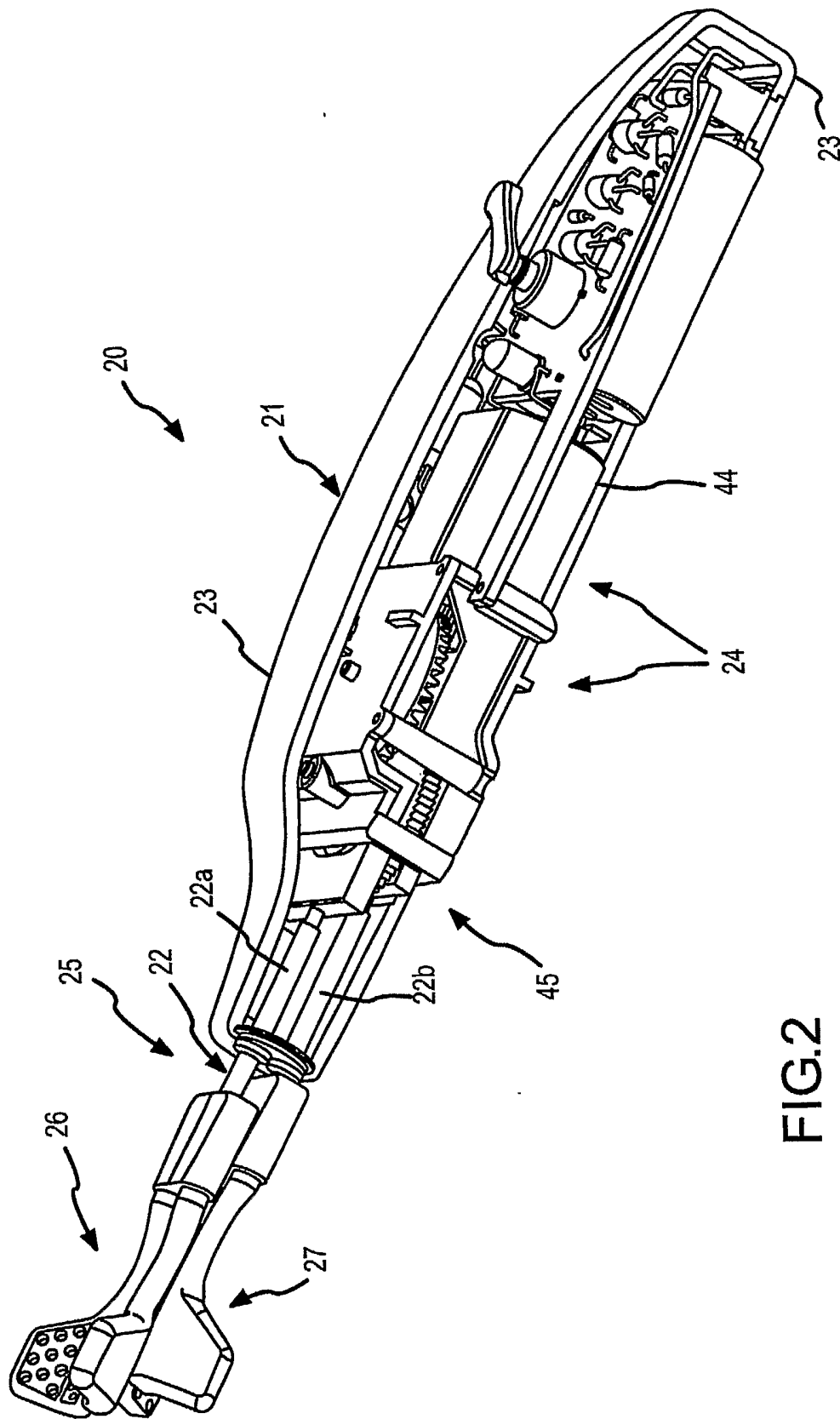

FIG.2

3/34

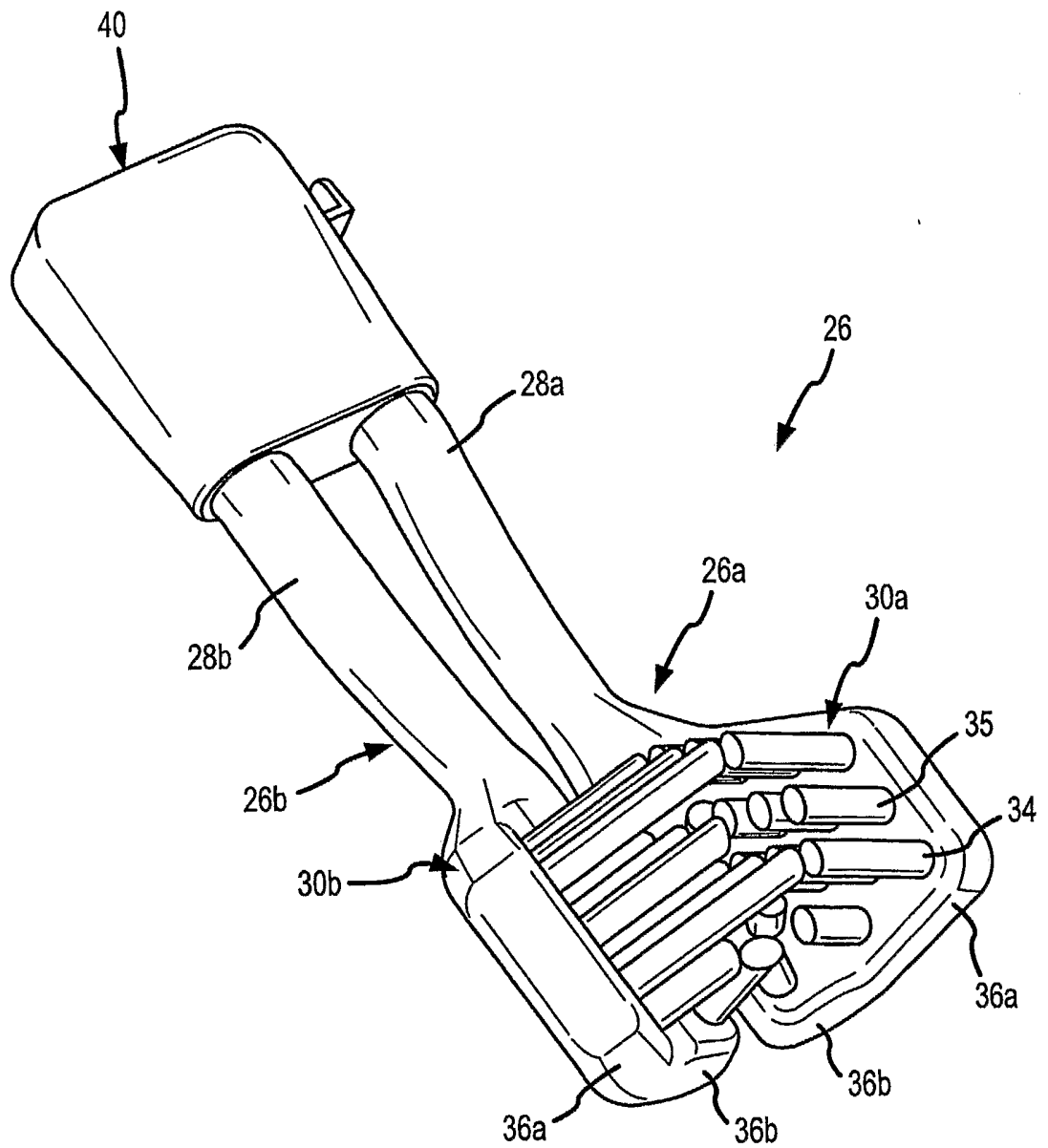

FIG.3A

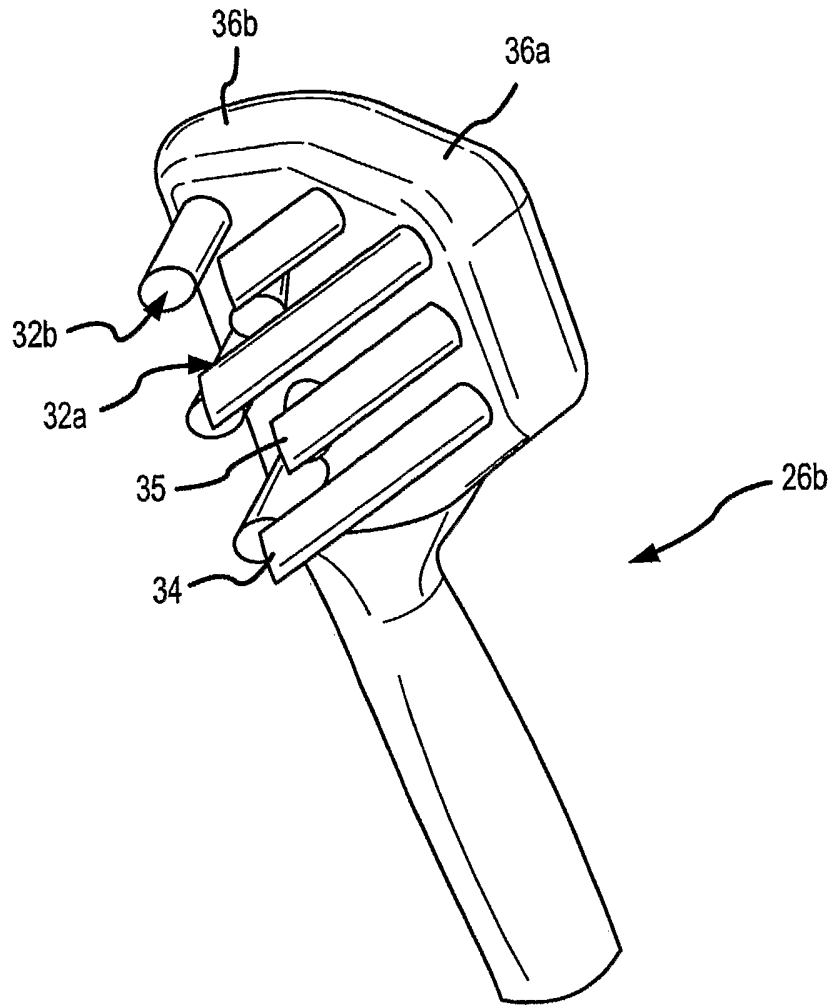

FIG.3B

5/34

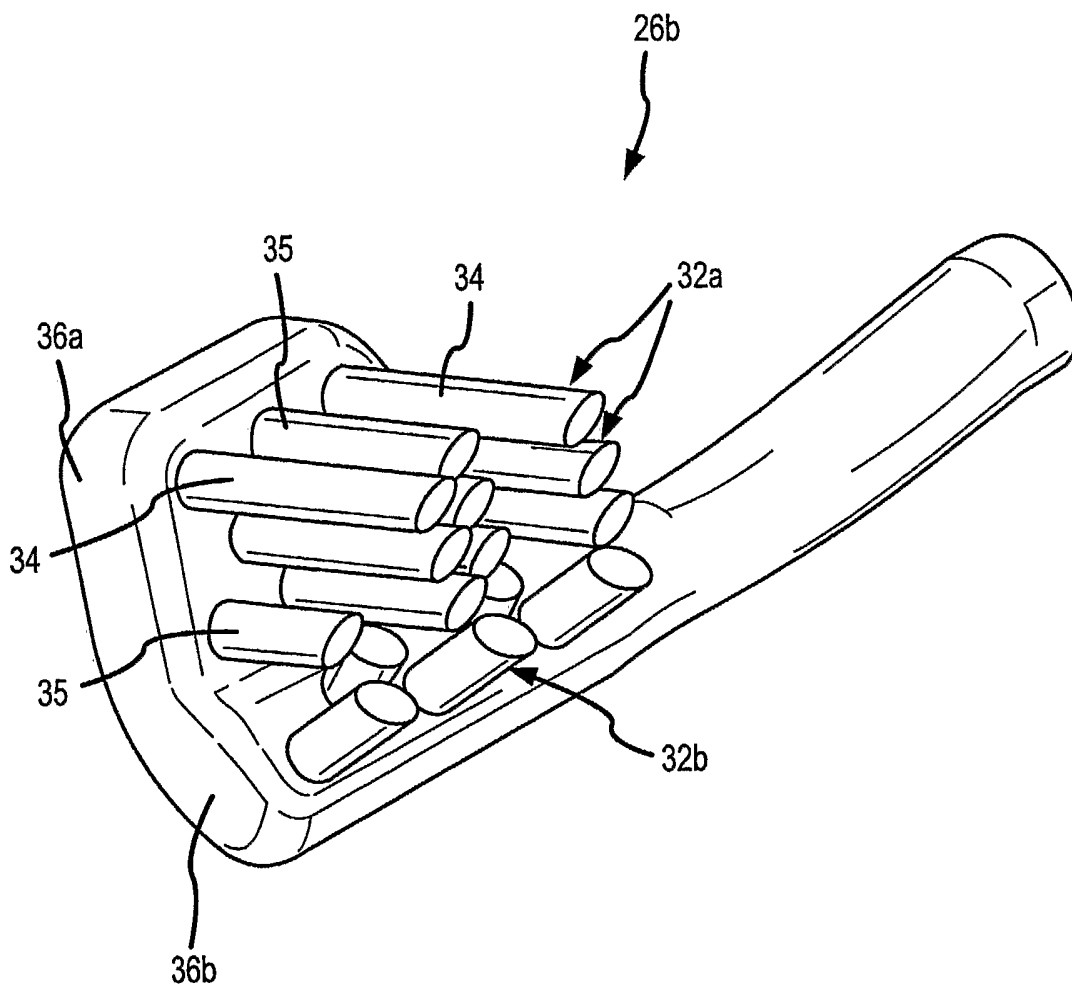

FIG.3C

6/34

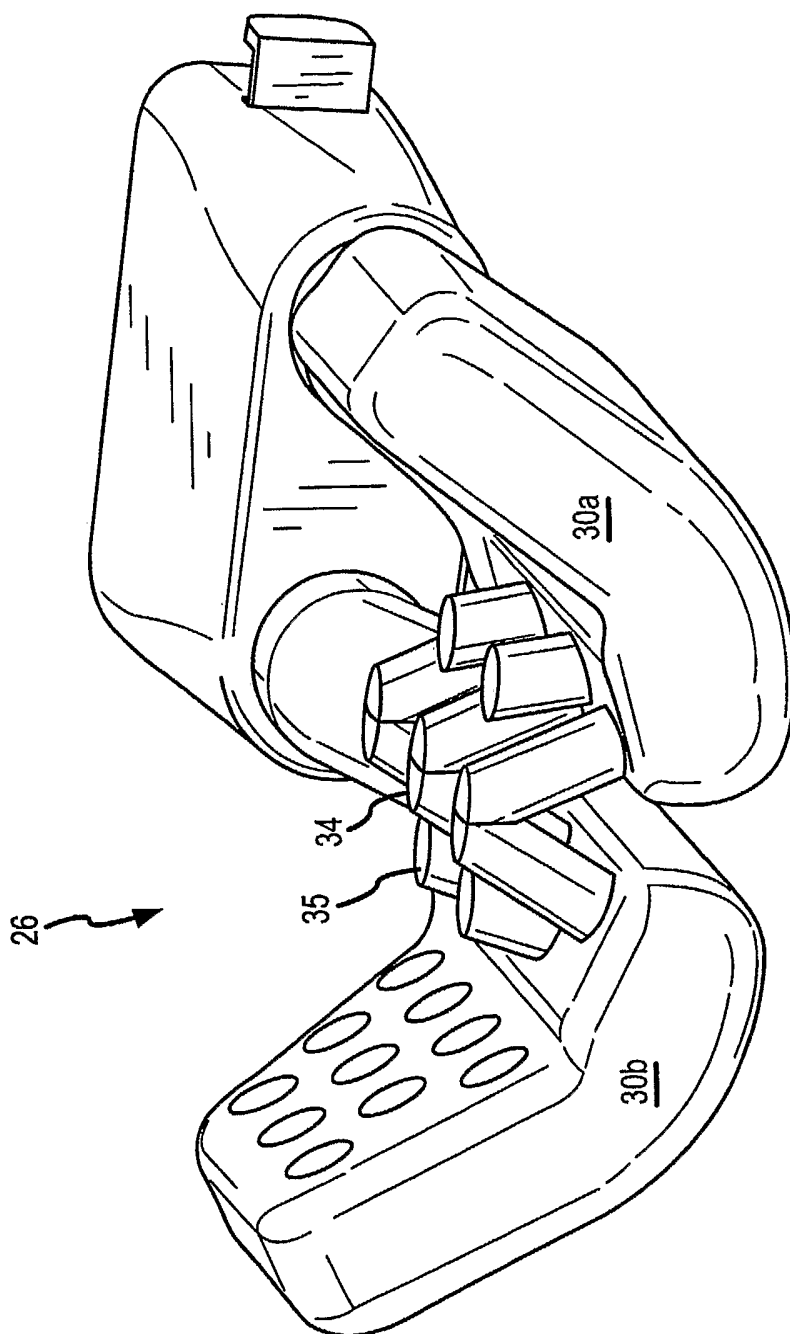

FIG.3D



7/34

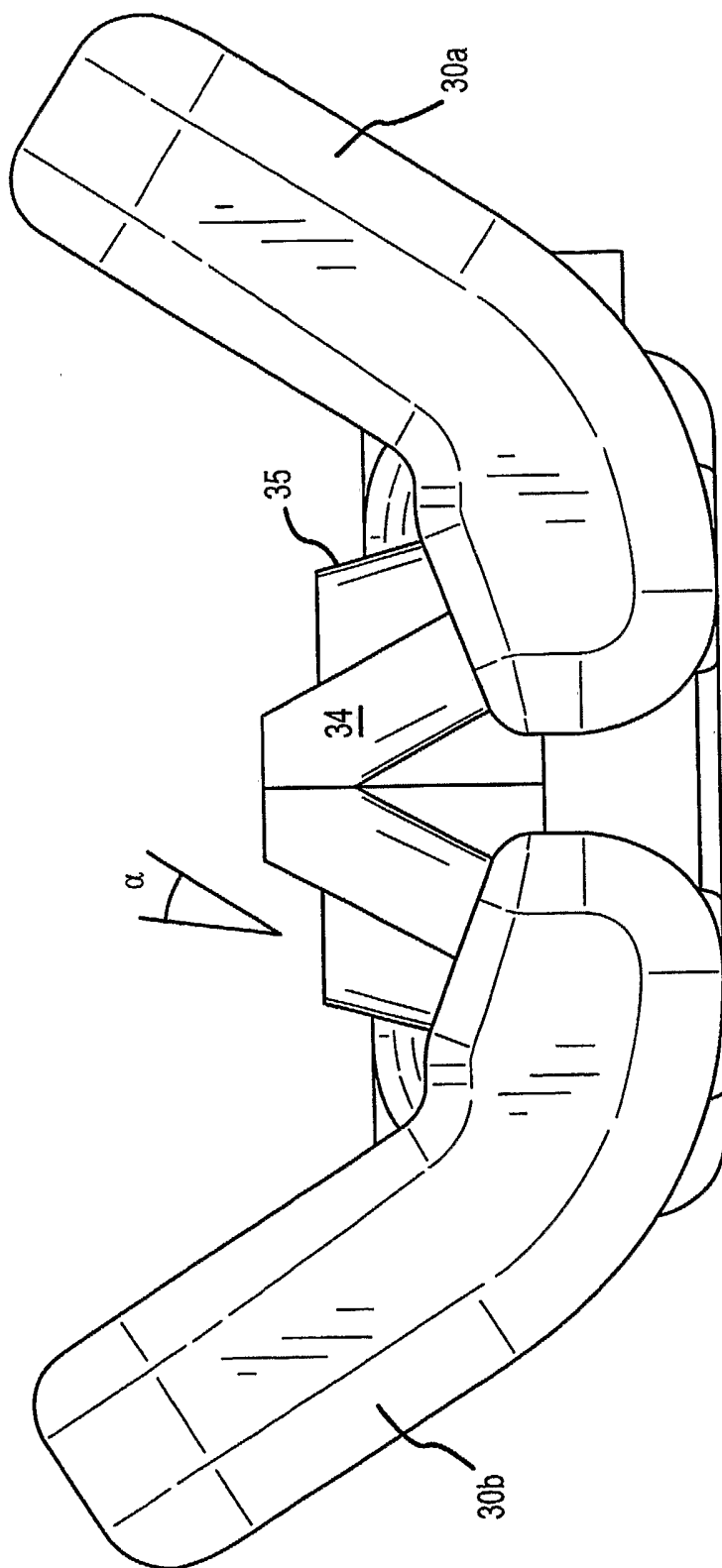

FIG.3E

8/34

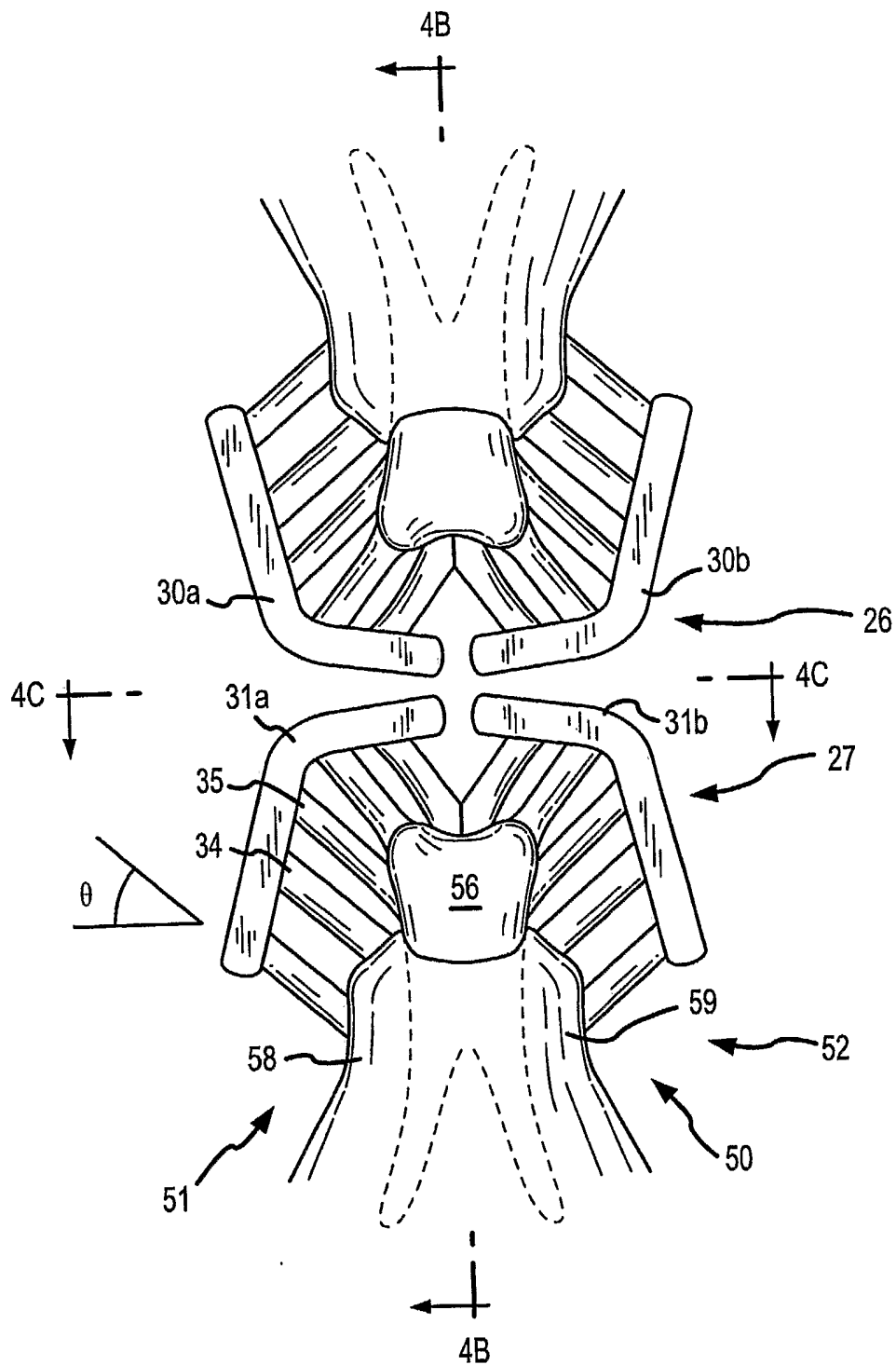

FIG.4A

SUBSTITUTE SHEET (RULE 26)

9/34

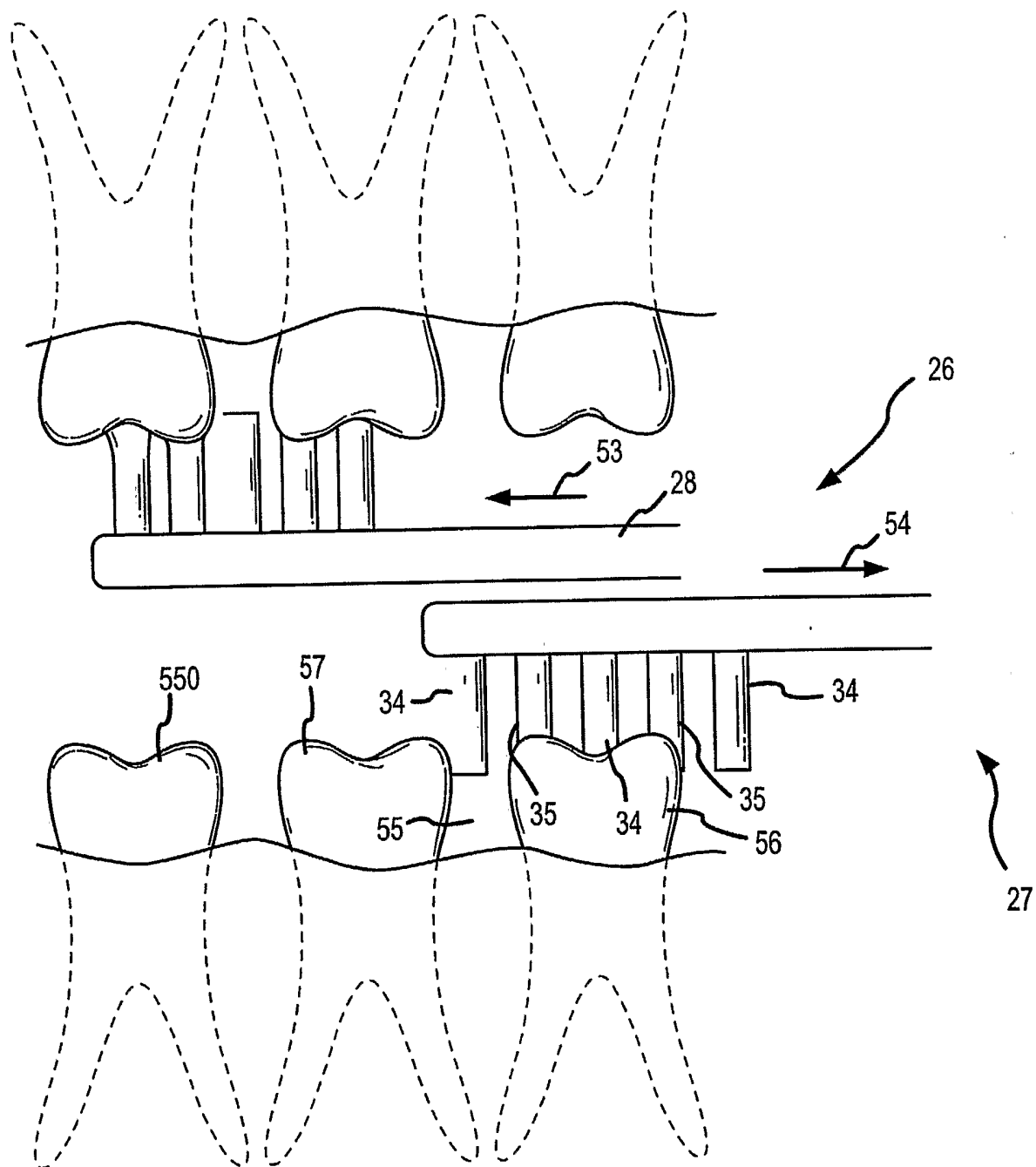

FIG.4B

10/34

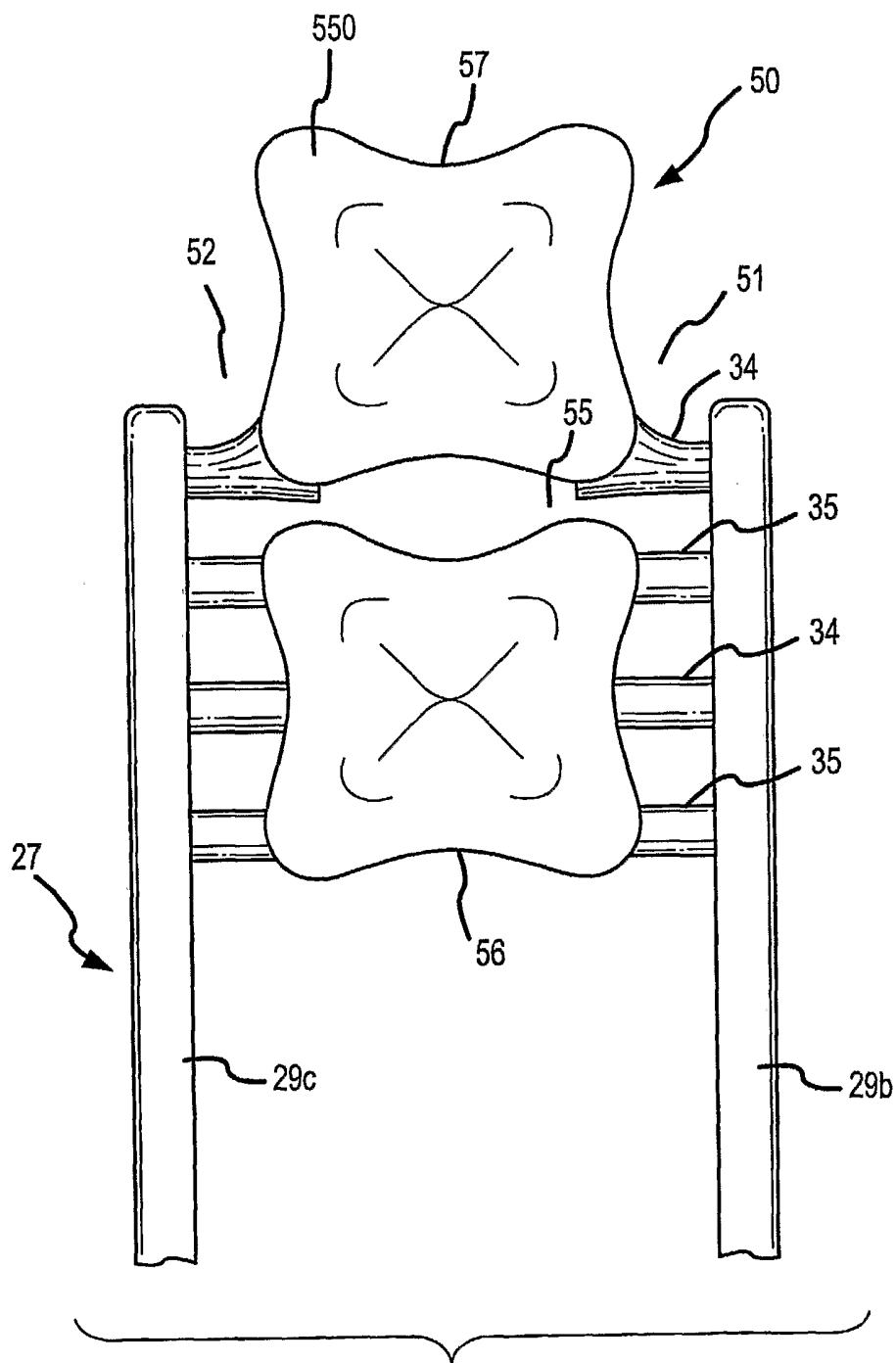

FIG.4C

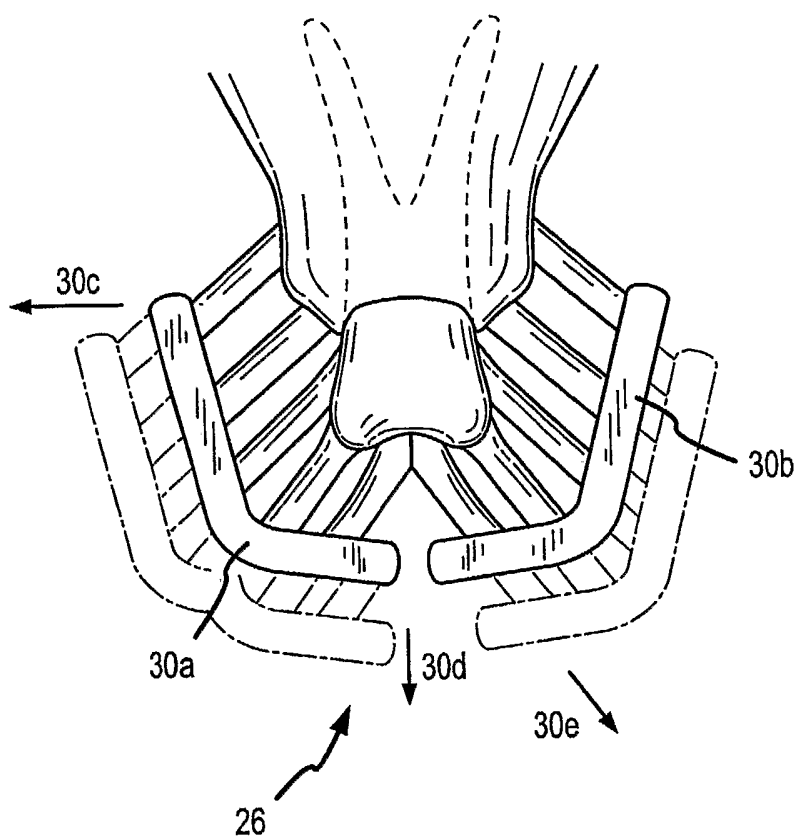

FIG.5A

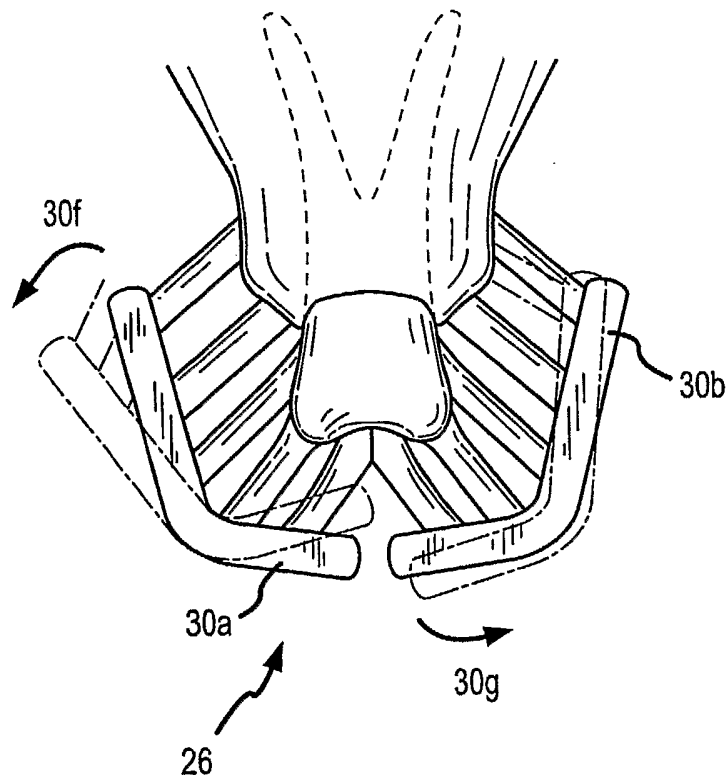

FIG.5B

13/34

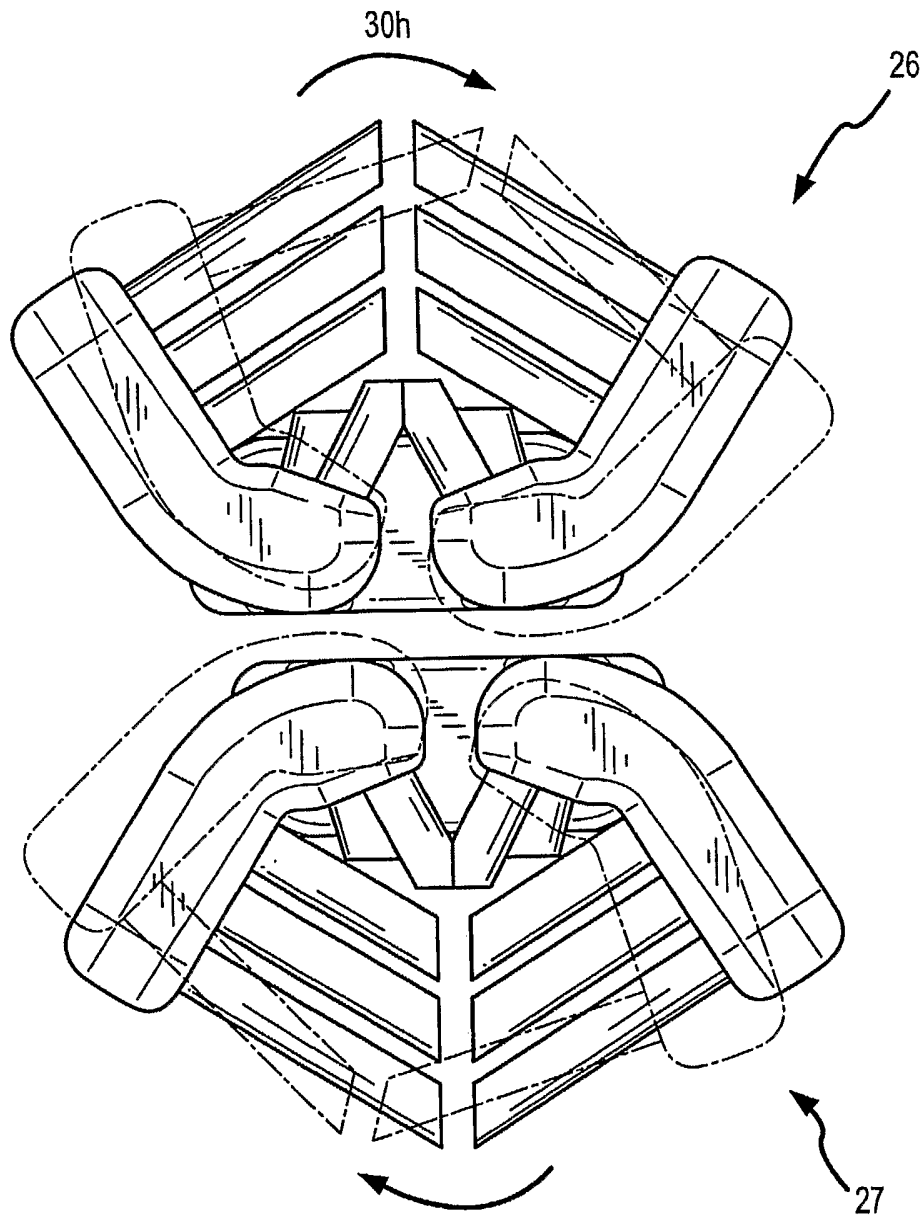

FIG.5C

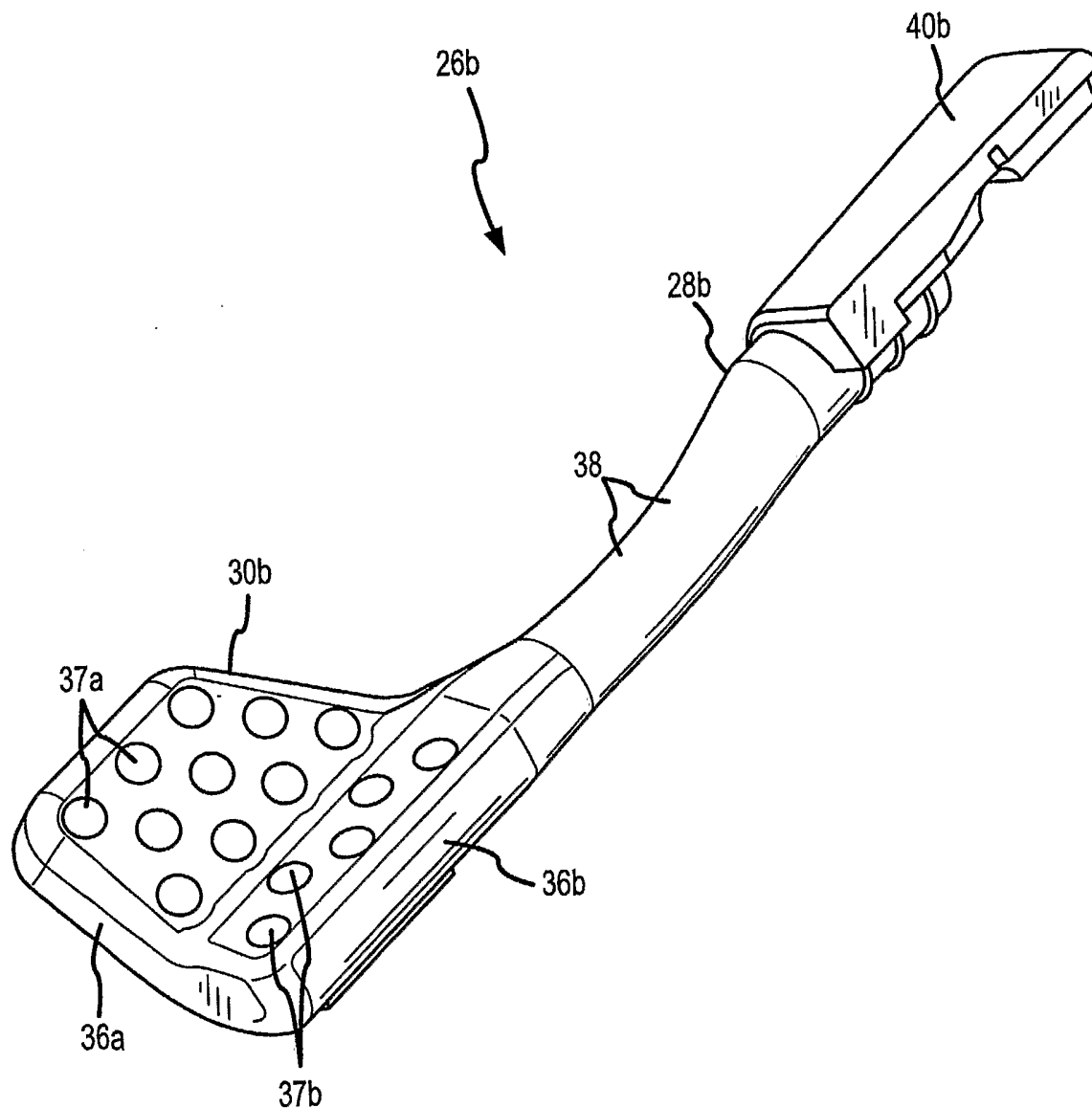

FIG.6A



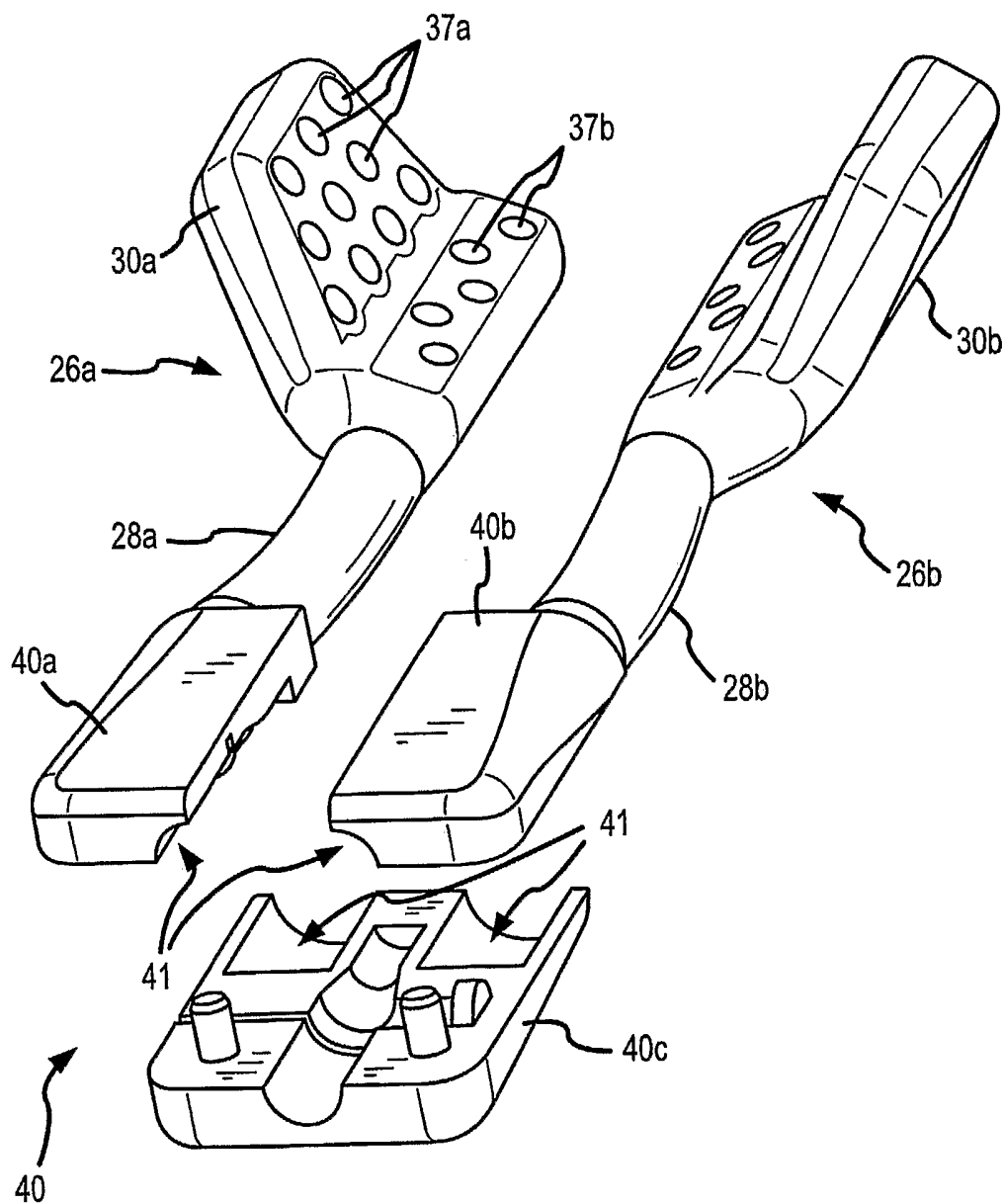

FIG.6B

16/34

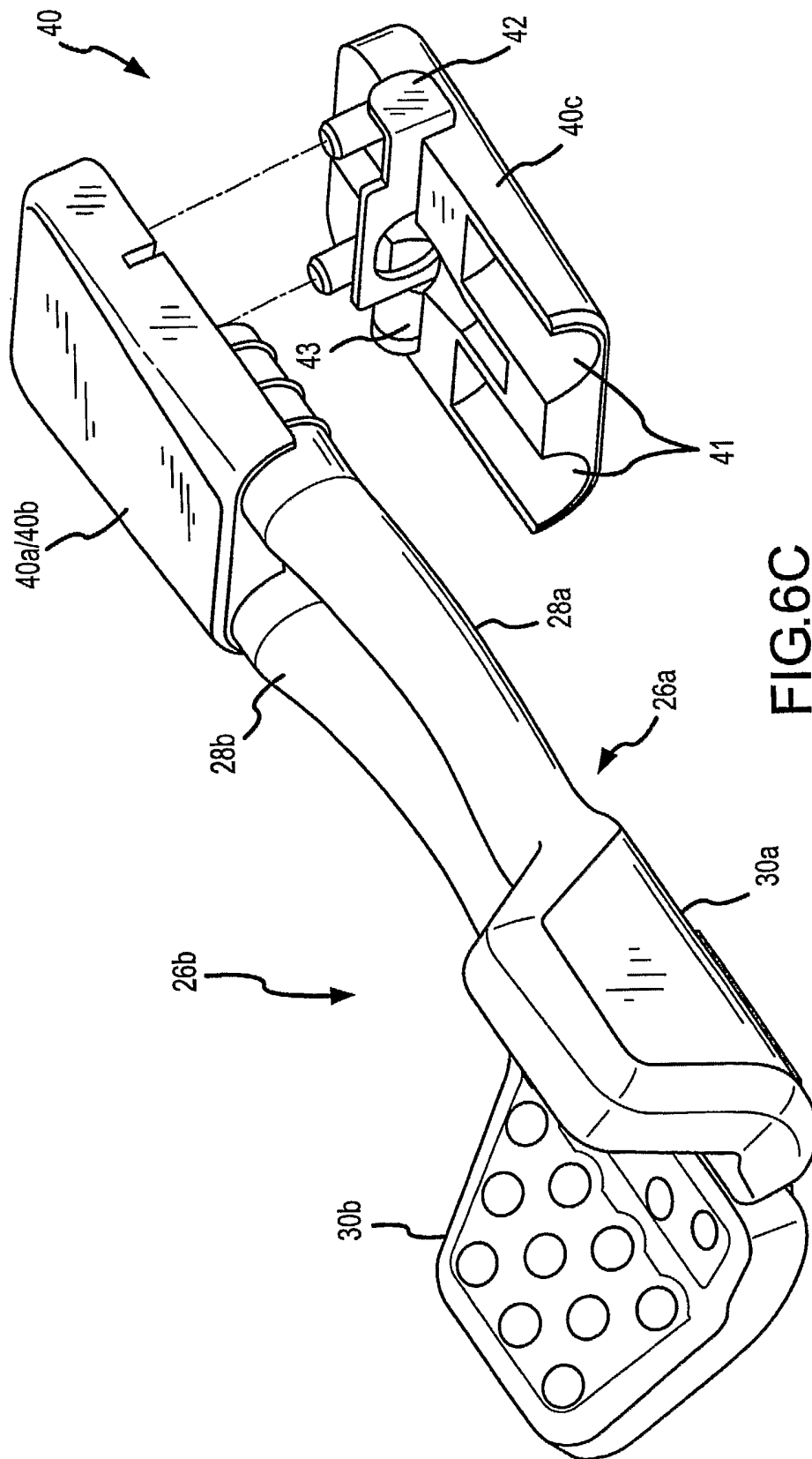

FIG. 6C

17/34

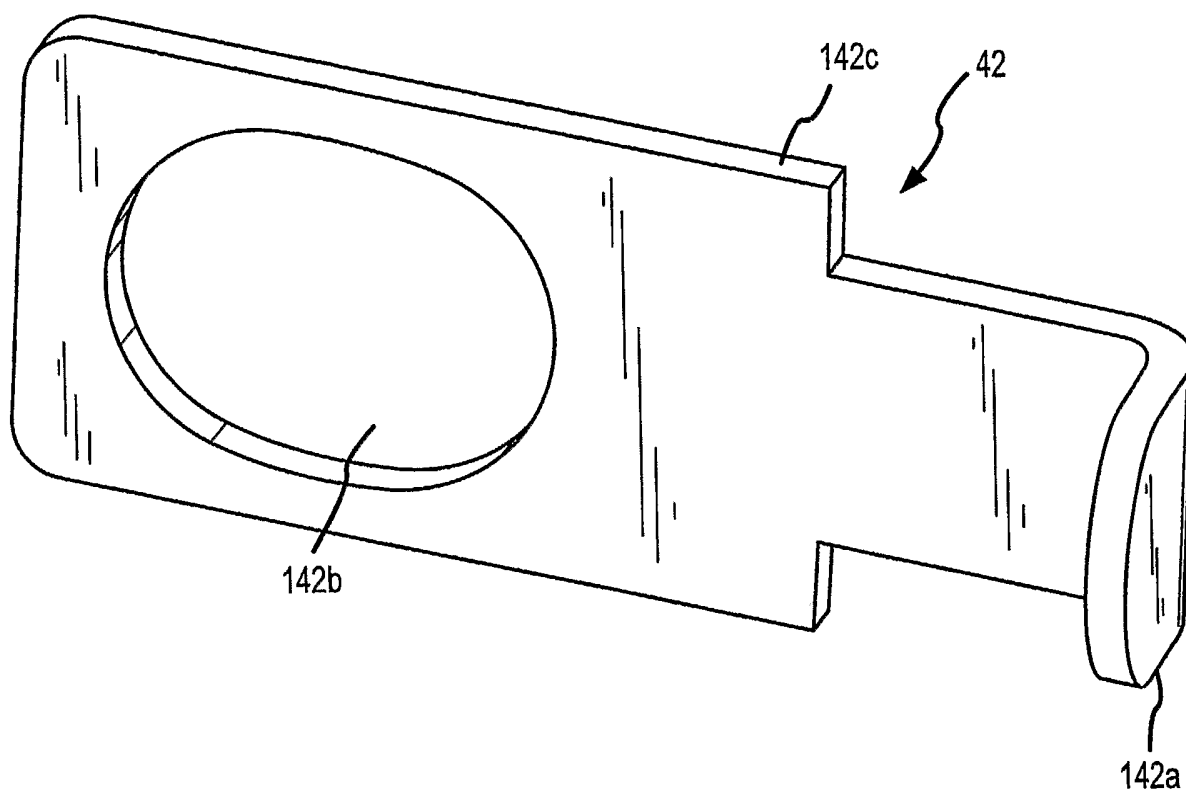

FIG.6D

18/34

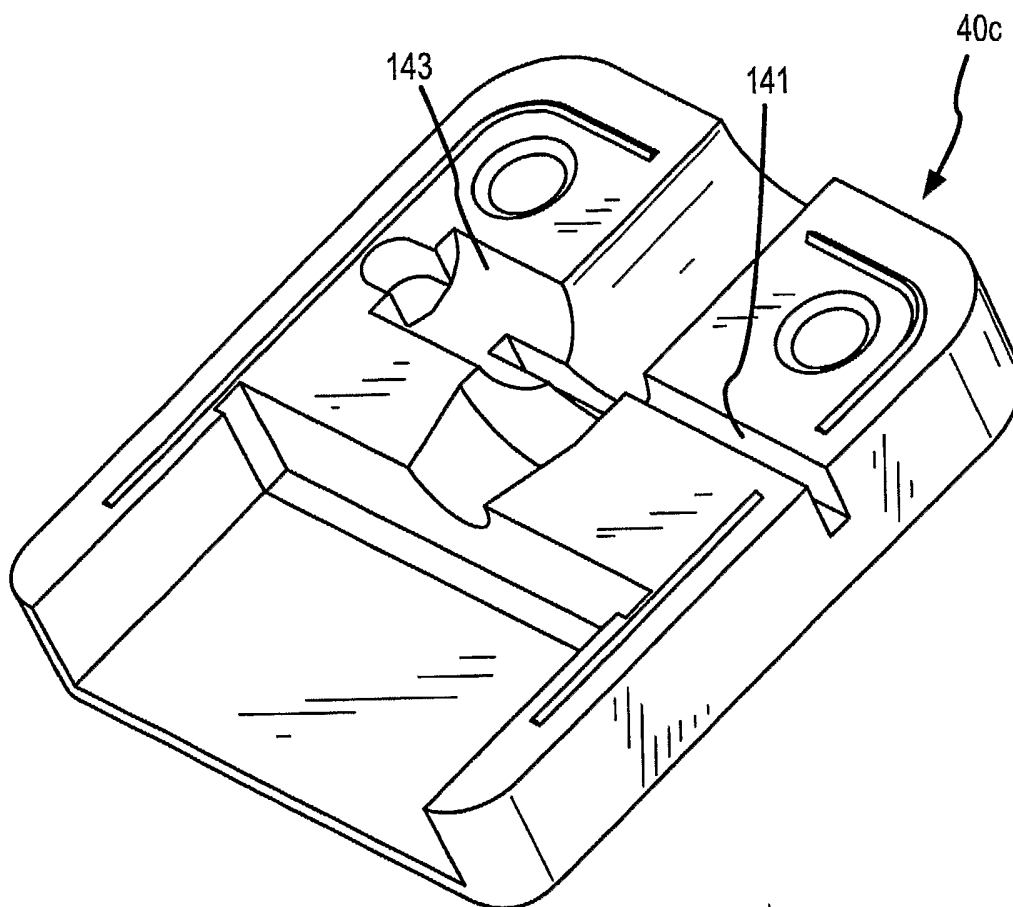

FIG.6E

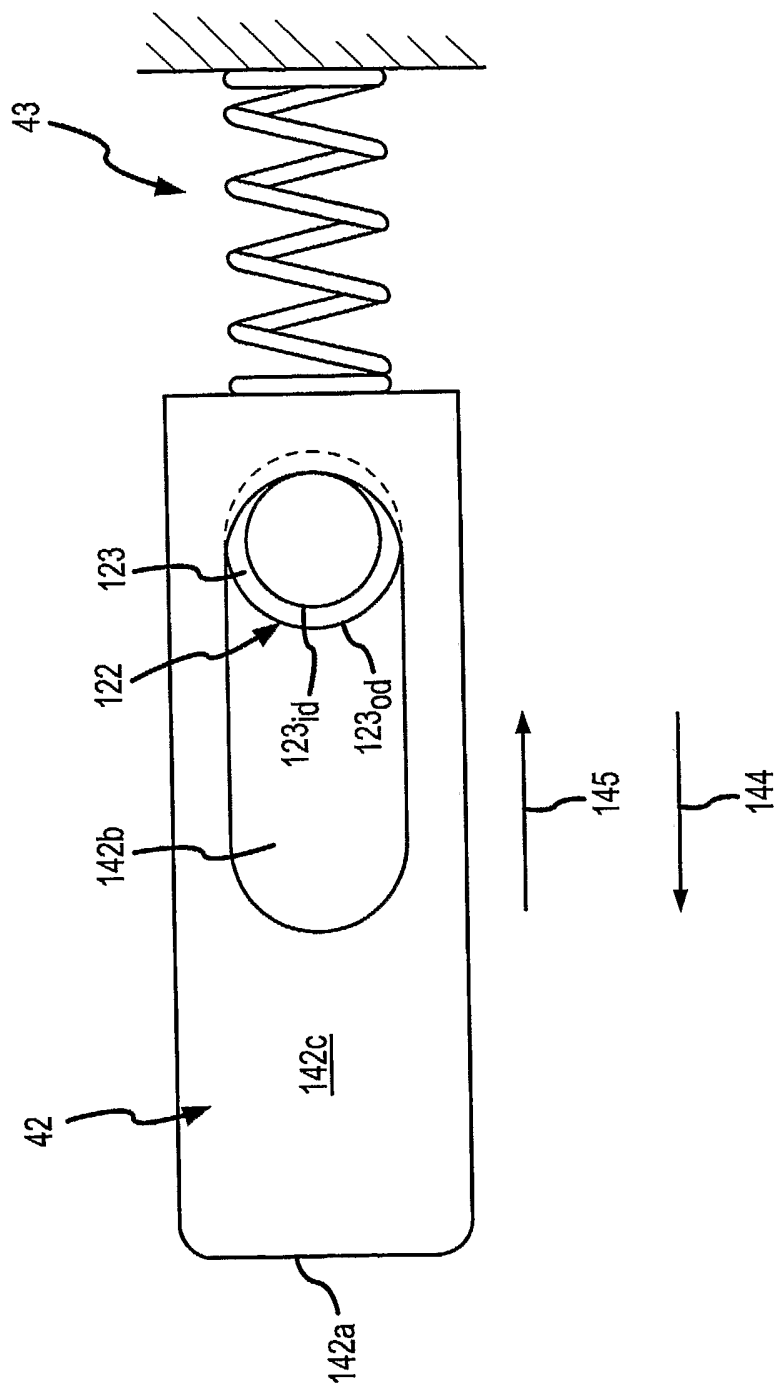

FIG.6F

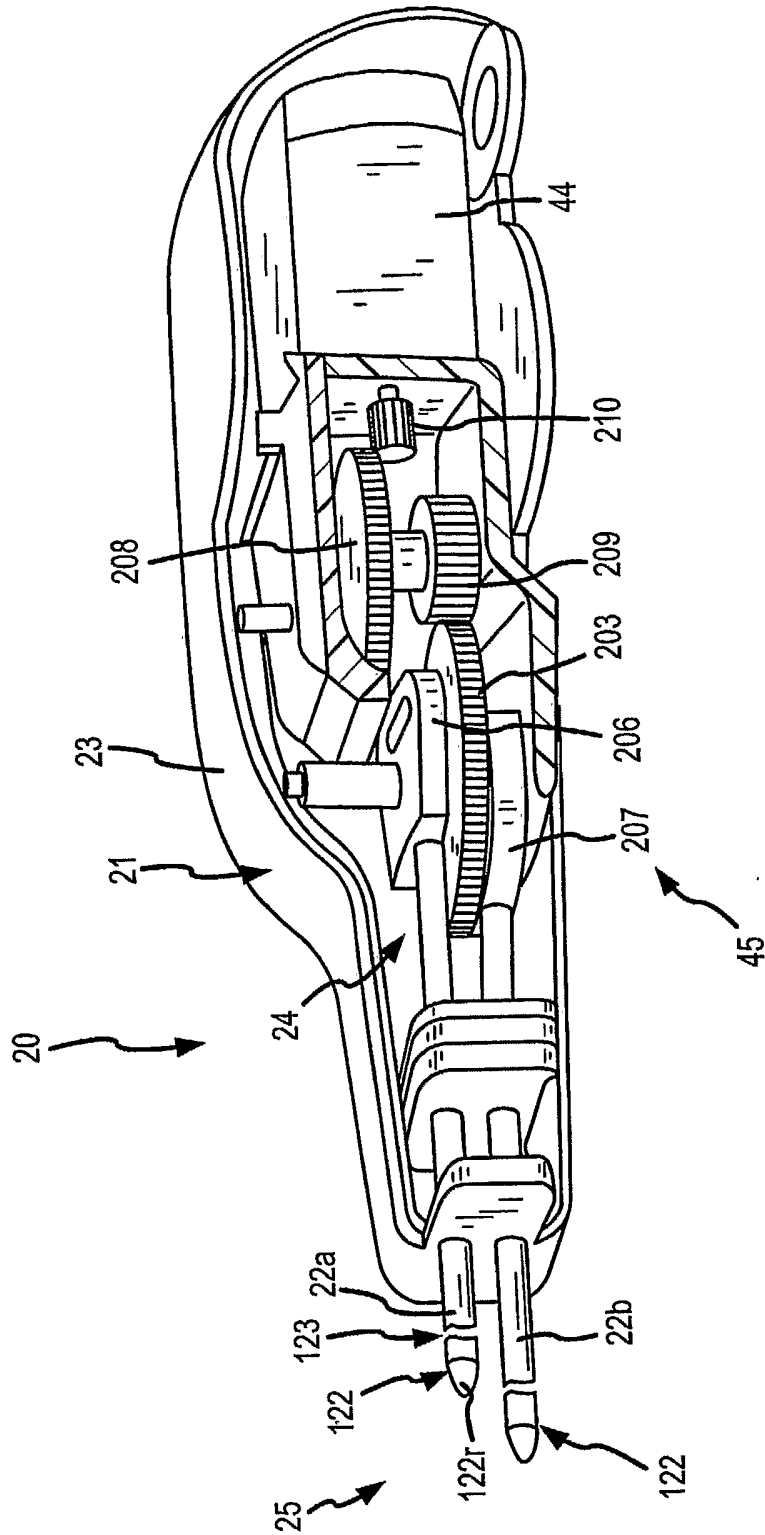

FIG.7A

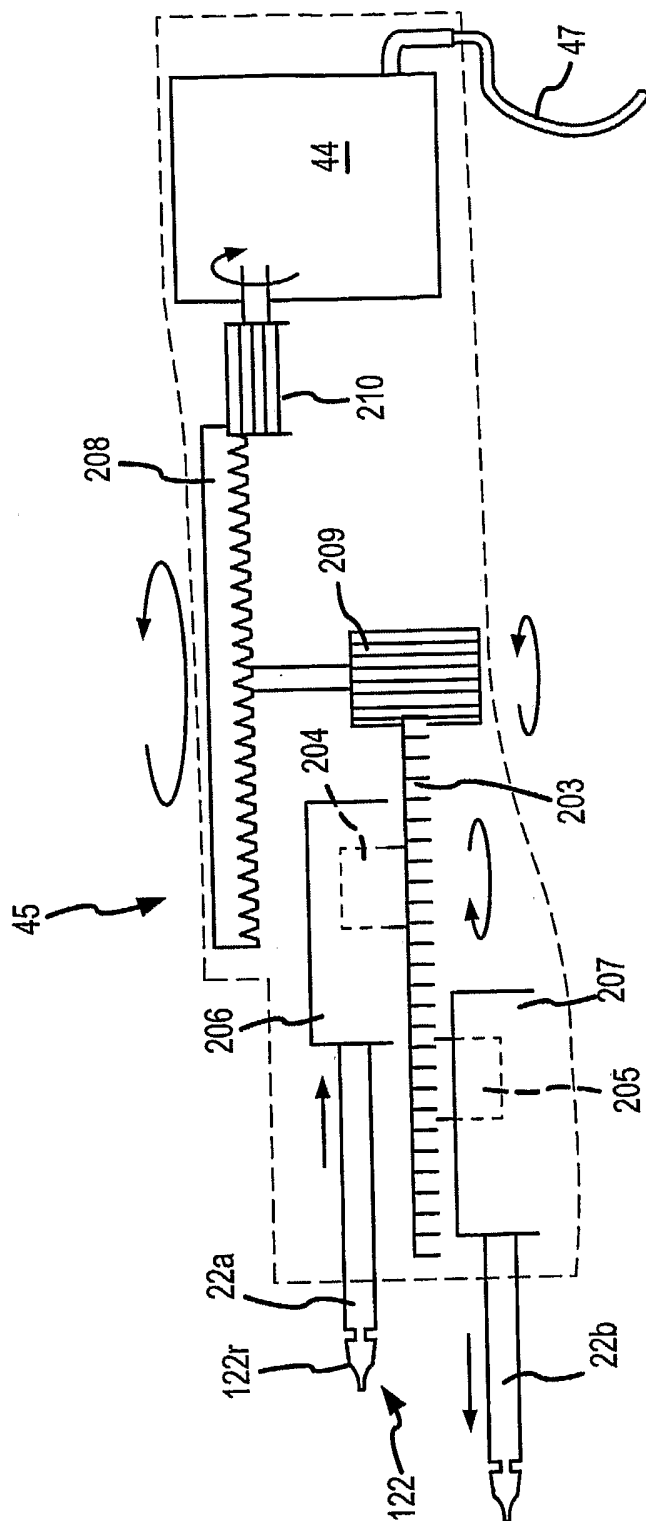

FIG.7B

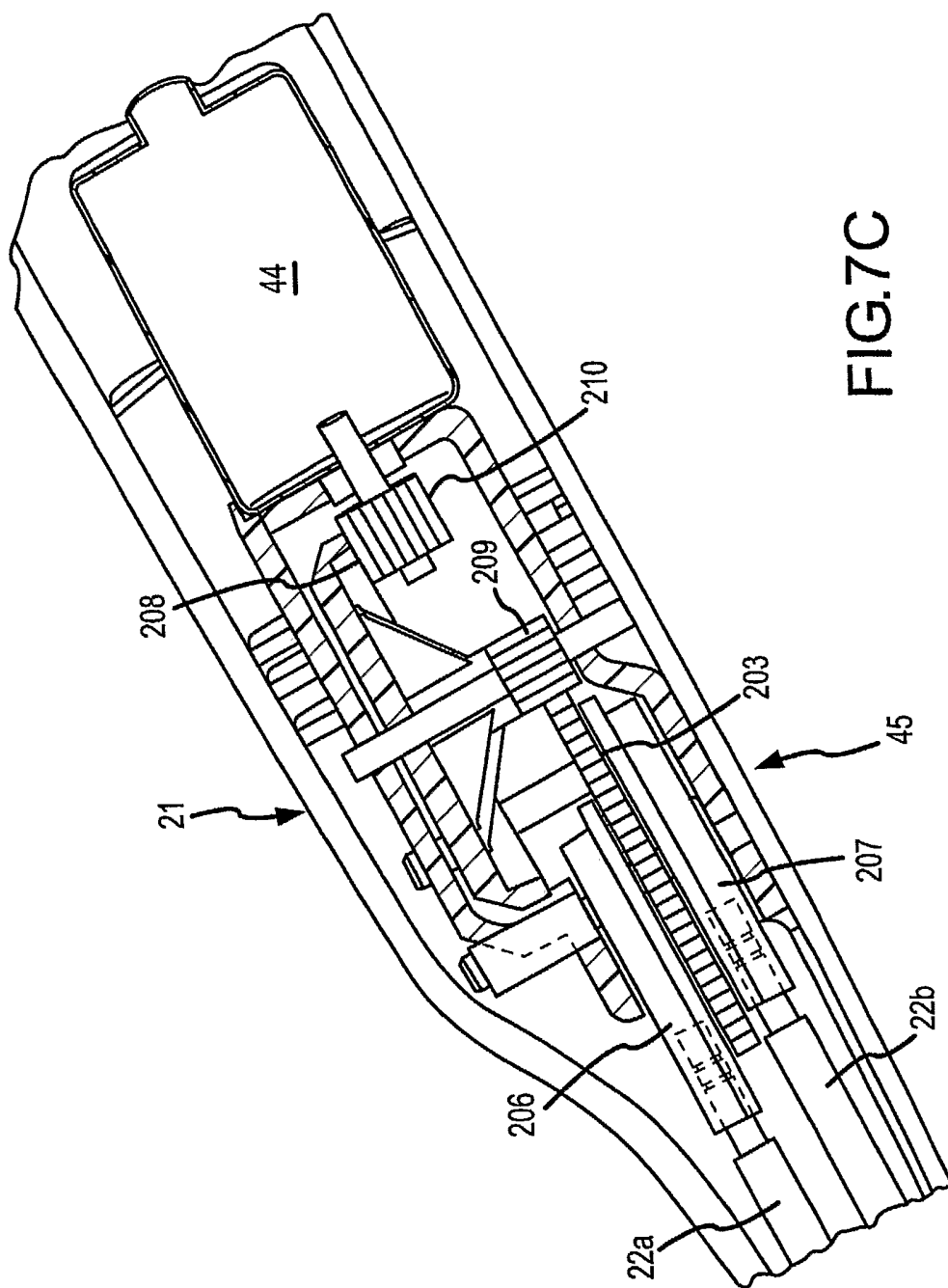

FIG. 7C



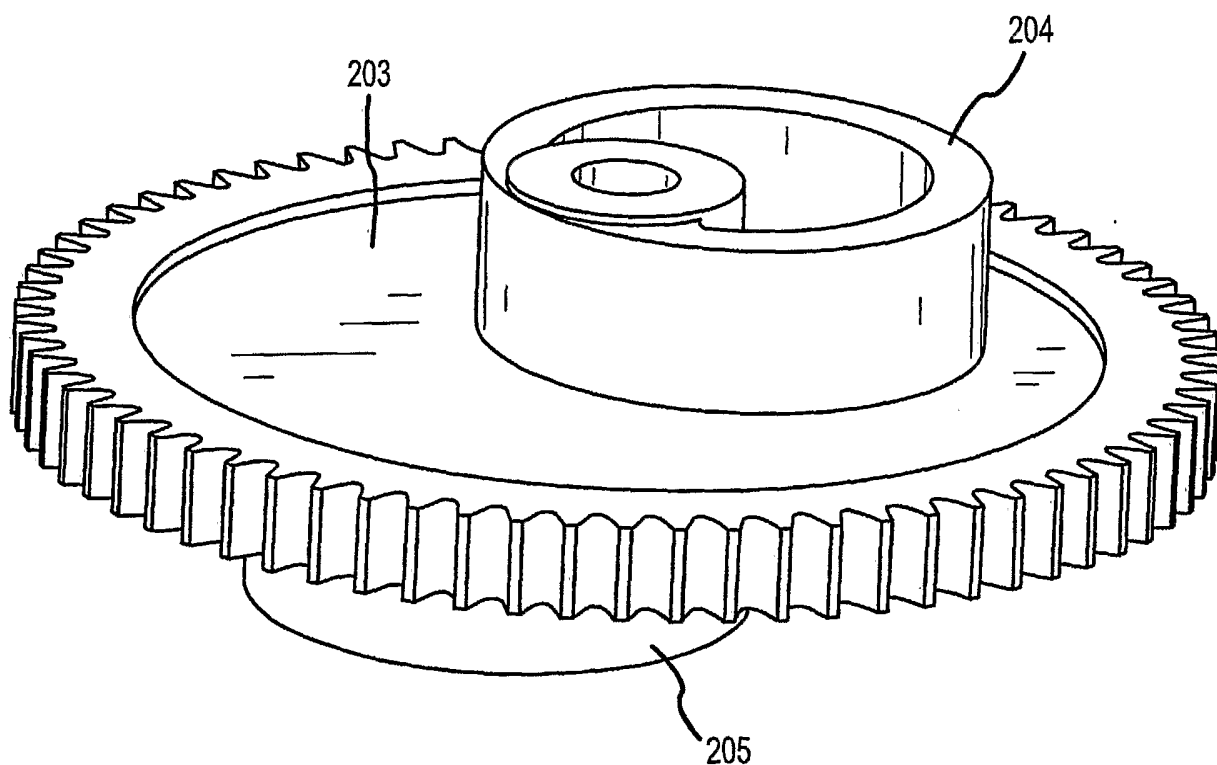

FIG.8A

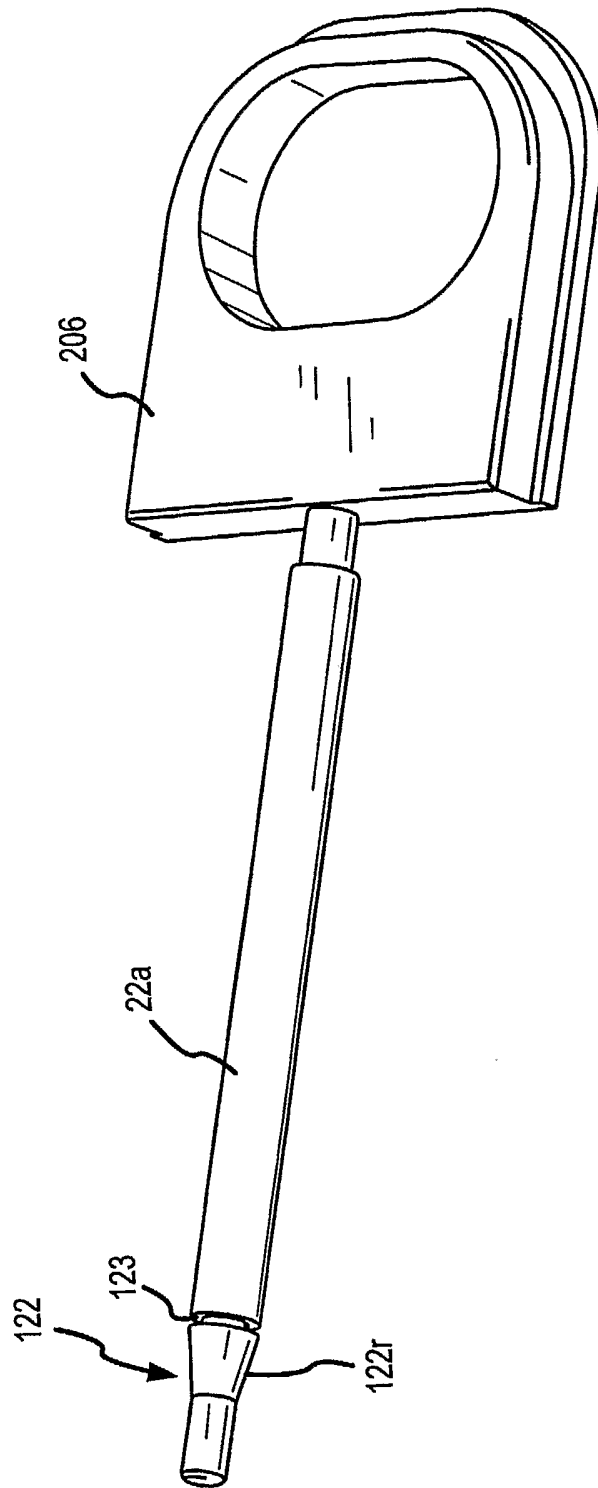

FIG.8B

25/34

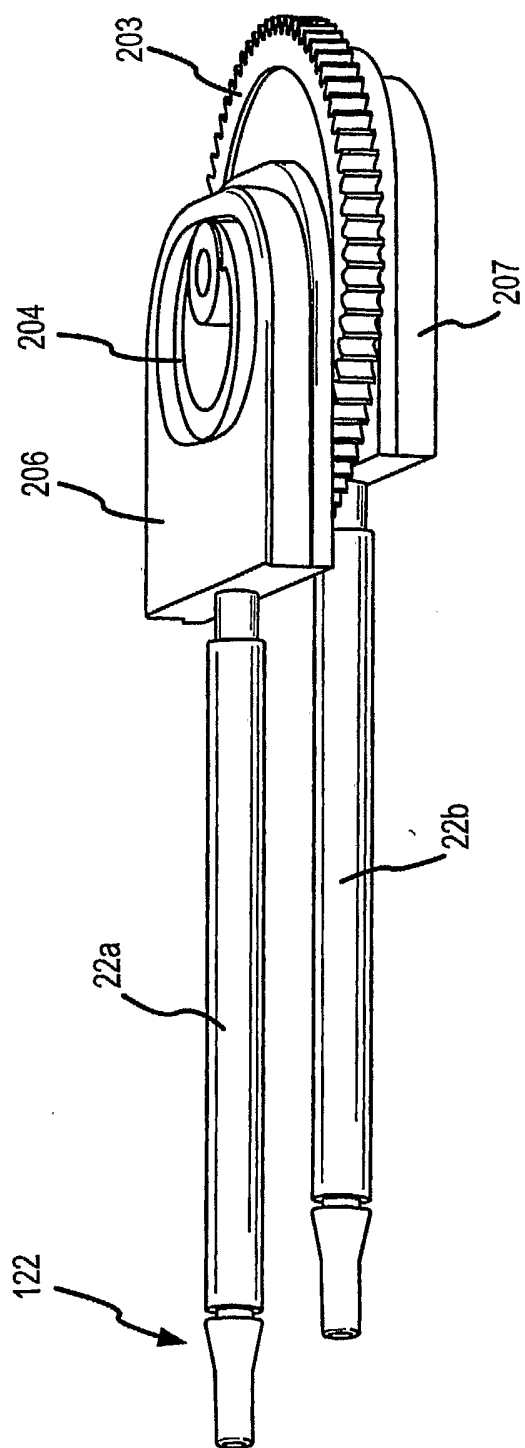

FIG.8C

26/34

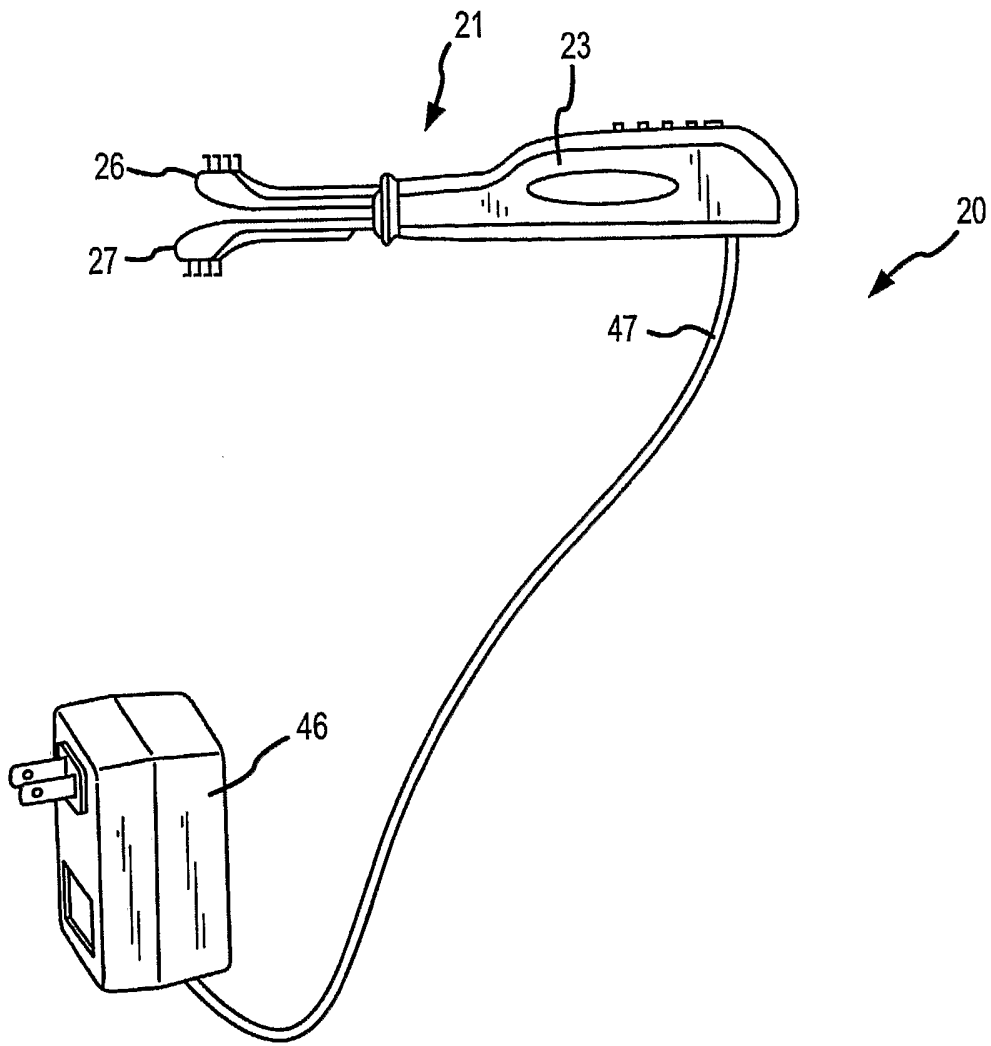

FIG.9A

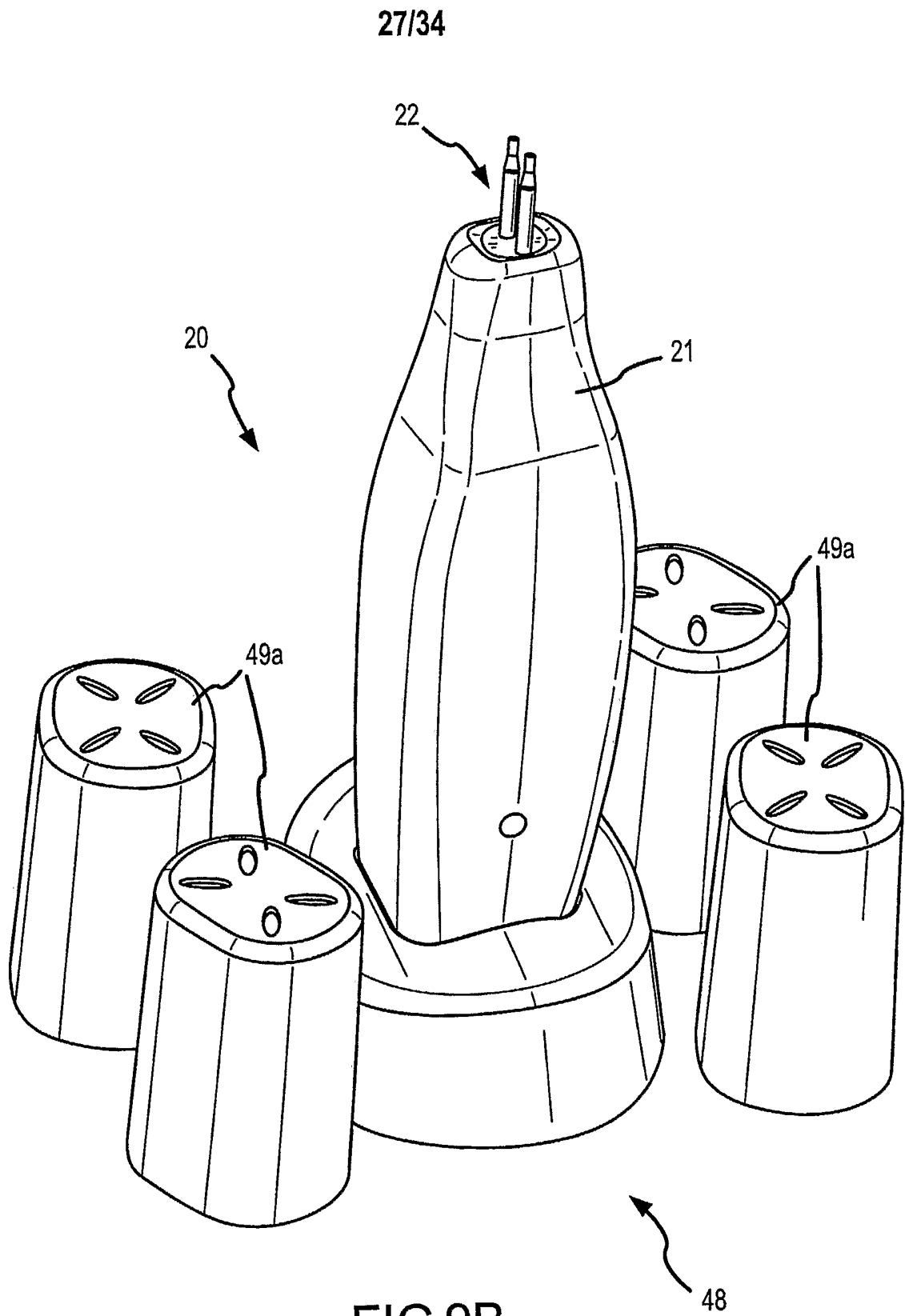

FIG.9B

28/34

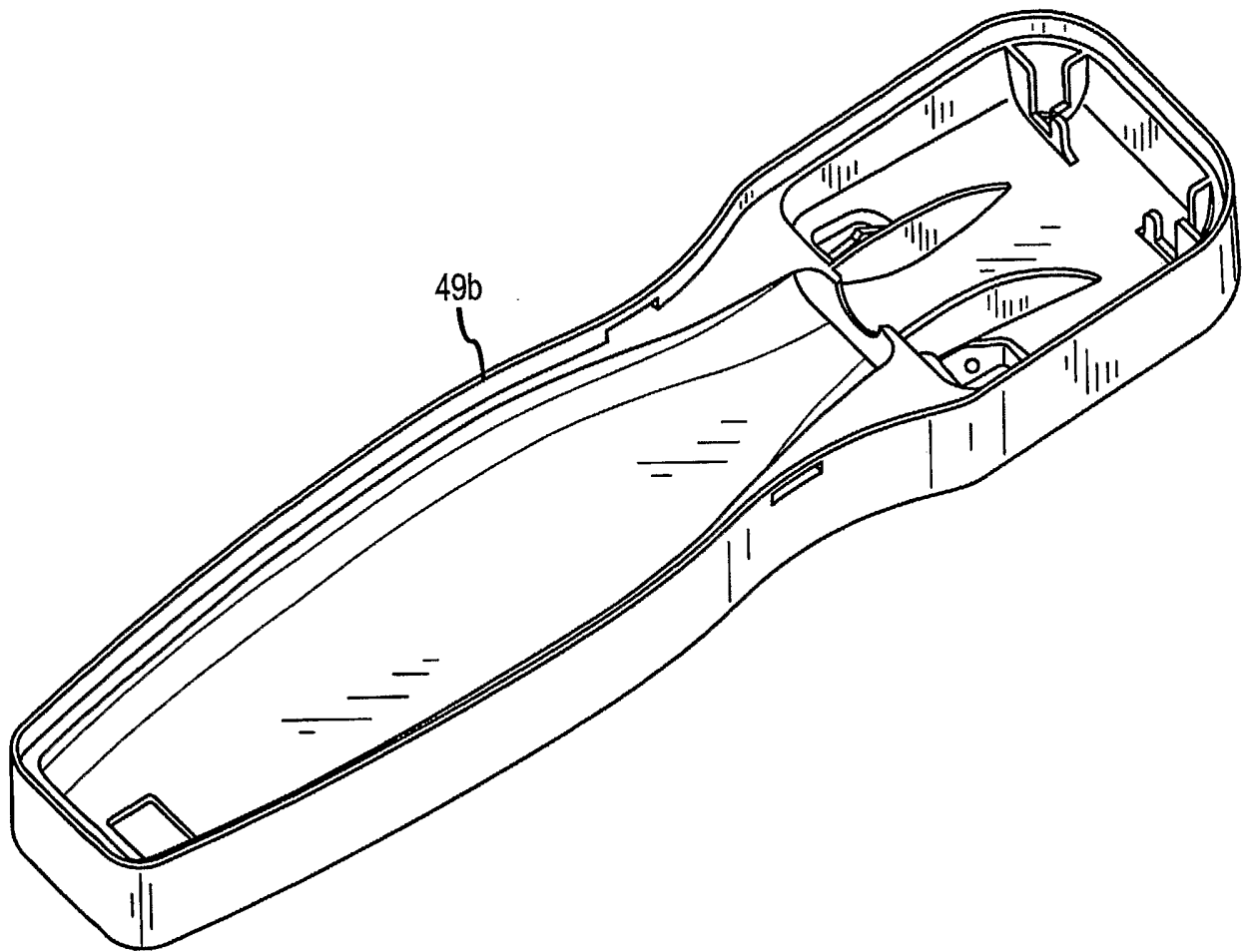

FIG.9C

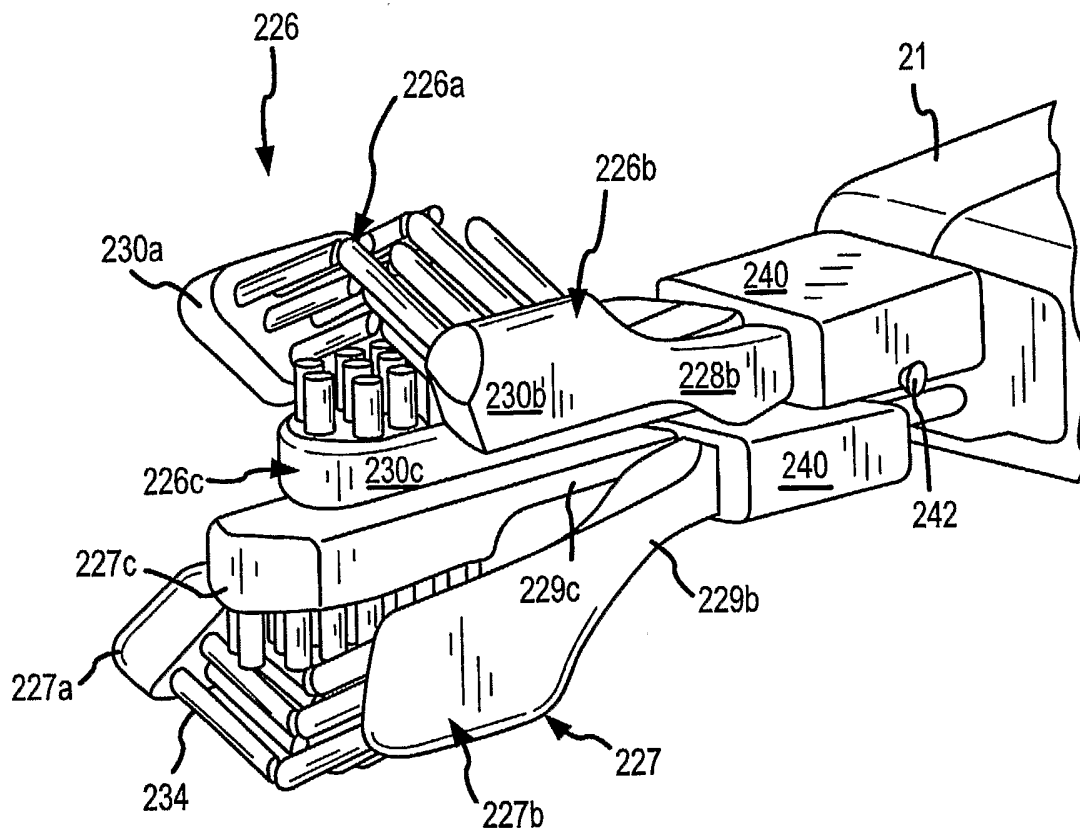

FIG.10A

30/34

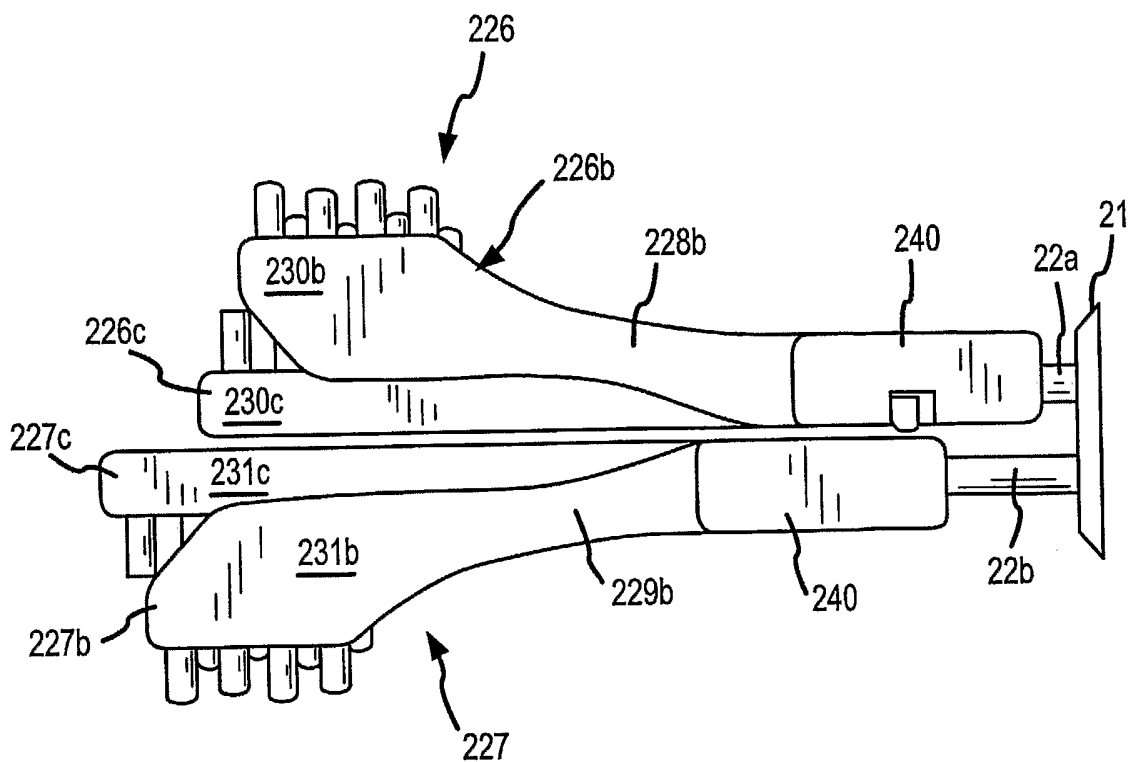

FIG.10B



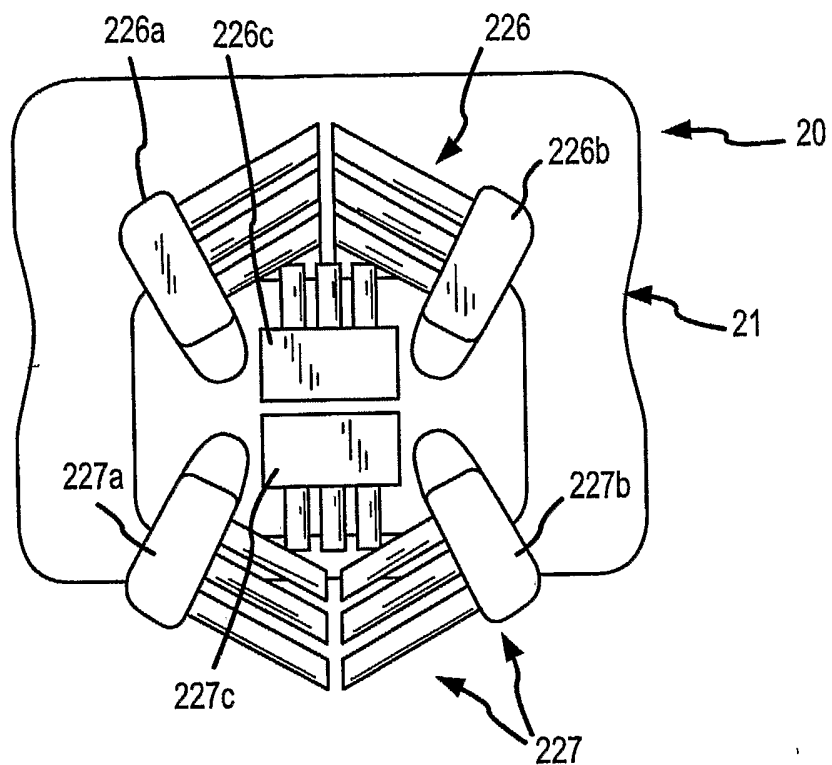

FIG.10C

32/34

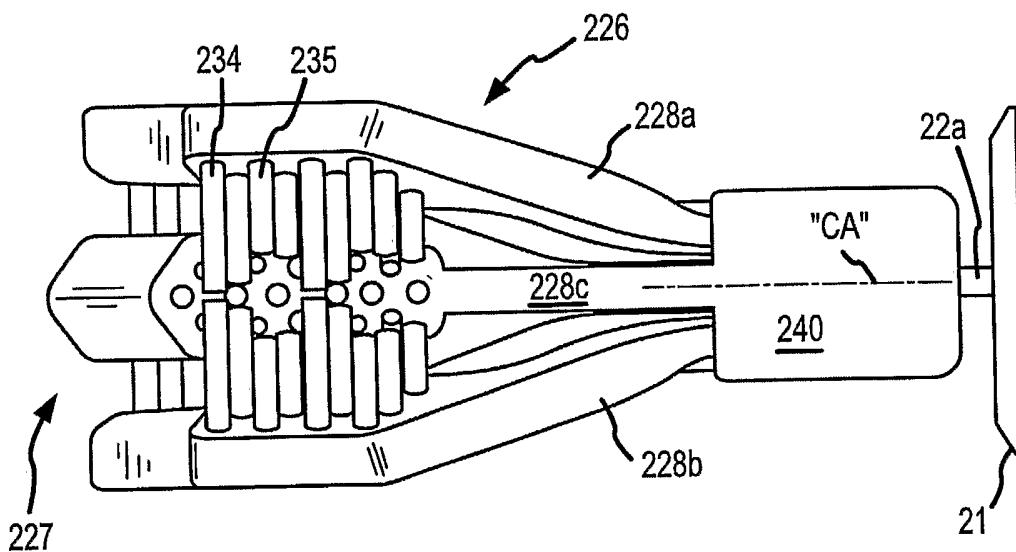

FIG.10D

33/34

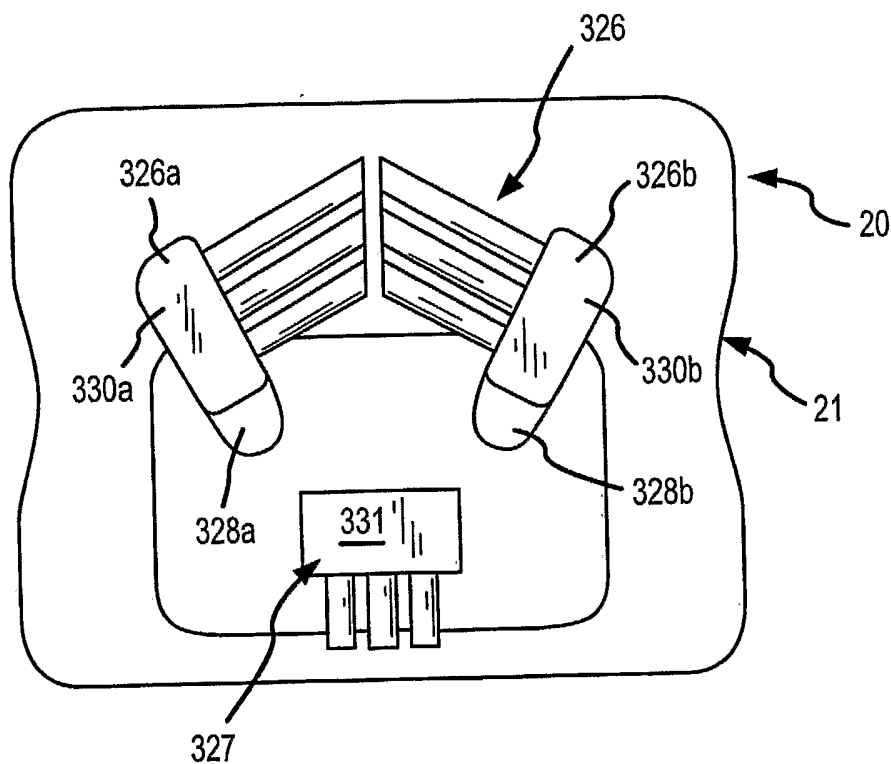

FIG.11A

34/34

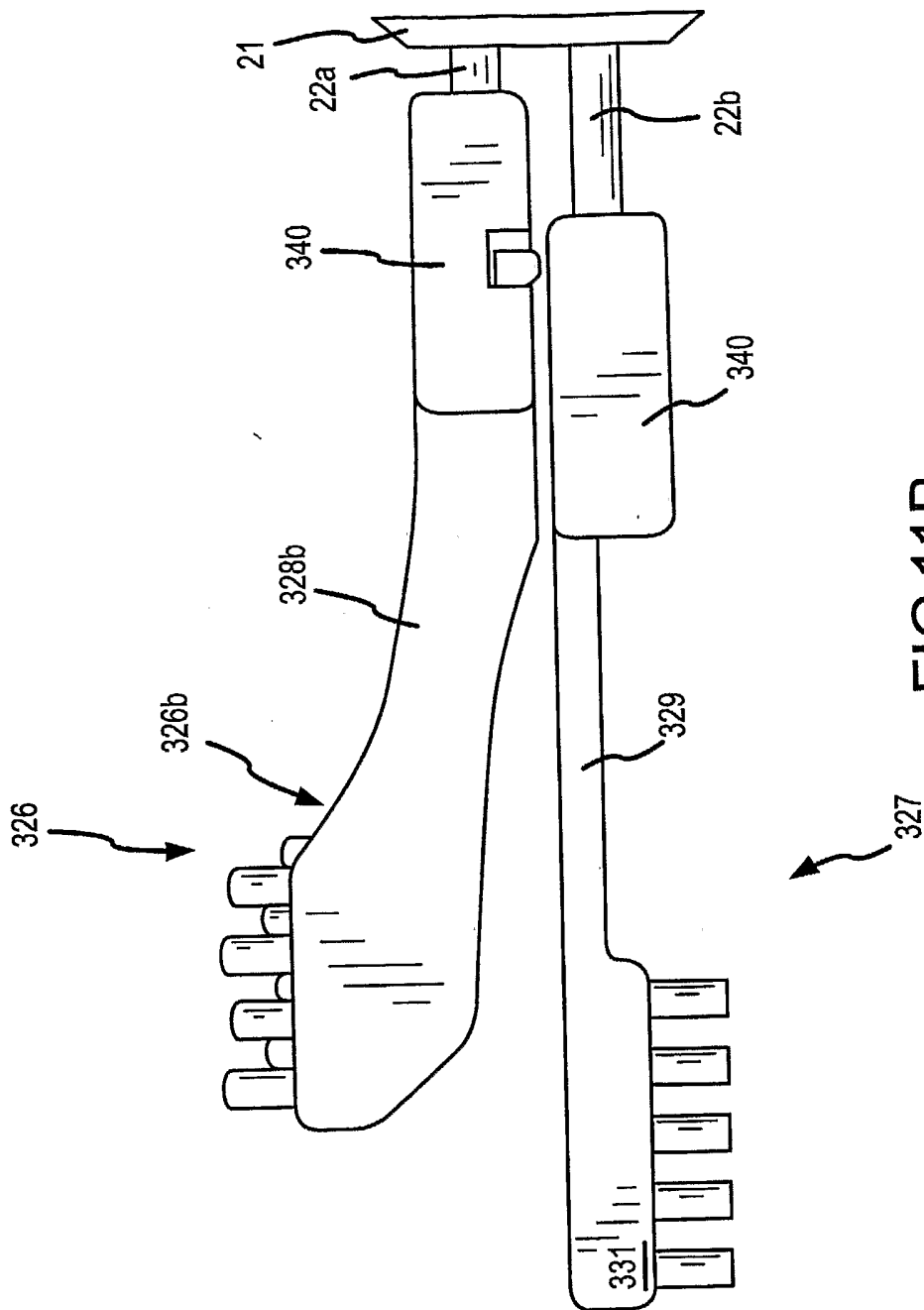

FIG.11B

**INTERNATIONAL SEARCH REPORT**

International application No.

PCT/US05/32436

**A. CLASSIFICATION OF SUBJECT MATTER**

IPC(7) : A46B 09/04, 13/00; A61C 17/00;

US CL : 15/22.1, 167.2

According to International Patent Classification (IPC) or to both national classification and IPC

**B. FIELDS SEARCHED**

Minimum documentation searched (classification system followed by classification symbols)

U.S. : 15/22.1, 22.2, 167.2; D4/105; A46B 09/04;

Documentation searched other than minimum documentation to the extent that such documents are included in the fields searched

Electronic data base consulted during the international search (name of data base and, where practicable, search terms used)

**C. DOCUMENTS CONSIDERED TO BE RELEVANT**

Category *	Citation of document, with indication, where appropriate, of the relevant passages	Relevant to claim No.
X	US 1,389,624 (CARROLL) 06 September 1921 (06.09.1921), figure 2.	1-28, 31-36, 40-49, 51-58
Y		29-30, 37-39, 50
X	US 5,647,385 (ZEBUHR) 15 July 1997 (15.07.1997), figure 3.	66-77
Y	US 3,196,299 (KOTT) 20 July 1965 (20.07.1965), figures.	37-39, 50
A	US 2,682,066 (KEELY) 29 June 1954 (29.06.1954), see Figures.	1-77
A	GB 2 192 784 A (MAK) 27 January 1988 (27.01.1988), figures 4-7.	1-77

Further documents are listed in the continuation of Box C.

See patent family annex.

\* Special categories of cited documents:

"A" document defining the general state of the art which is not considered to be of particular relevance

"B" earlier application or patent published on or after the international filing date

"L" document which may throw doubts on priority claim(s) or which is cited to establish the publication date of another citation or other special reason (as specified)

"O" document referring to an oral disclosure, use, exhibition or other means

"P" document published prior to the international filing date but later than the priority date claimed

"T" later document published after the international filing date or priority date and not in conflict with the application but cited to understand the principle or theory underlying the invention

"X" document of particular relevance; the claimed invention cannot be considered novel or cannot be considered to involve an inventive step when the document is taken alone

"Y" document of particular relevance; the claimed invention cannot be considered to involve an inventive step when the document is combined with one or more other such documents, such combination being obvious to a person skilled in the art

"&" document member of the same patent family

Date of the actual completion of the international search

03 January 2006 (03.01.2006)

Date of mailing of the international search report

18 JAN 2006

Name and mailing address of the ISA/US

Mail Stop PCT, Attn: ISA/US  
Commissioner for Patents  
P.O. Box 1450  
Alexandria, Virginia 22313-1450

Facsimile No. (571) 273-3201

Authorized officer

Laura Guidotti

Telephone No. (571) 272-1700