

**(12) STANDARD PATENT**  
**(19) AUSTRALIAN PATENT OFFICE**

(11) Application No. **AU 2004231188 B2**

(54) Title  
**Bipolar forceps having monopolar extension**

(51) International Patent Classification(s)  
**A61B 17/28** (2006.01)                      **A61B 18/14** (2006.01)  
**A61B 1/00** (2006.01)                      **A61B 18/16** (2006.01)  
**A61B 18/12** (2006.01)

(21) Application No: **2004231188**                      (22) Date of Filing: **2004.11.17**

(30) Priority Data

(31) Number                      (32) Date                      (33) Country  
**60/520579**                      **2003.11.17**                      **US**

(43) Publication Date: **2005.06.02**

(43) Publication Journal Date: **2005.06.02**

(44) Accepted Journal Date: **2010.11.11**

(71) Applicant(s)  
**Covidien AG**

(72) Inventor(s)  
**Dycus, Sean T.;Lawes, Kate**

(74) Agent / Attorney  
**Spruson & Ferguson, Level 35 St Martins Tower 31 Market Street, Sydney, NSW, 2000**

(56) Related Art  
**US 5573424 (POPPE) 12 November 1996**  
**WO 2002/080795 (SHERWOOD SERVICES AG) 17 October 2002**

## BIPOLAR FORCEPS HAVING MONOPOLAR EXTENSION

### Abstract

An endoscopic forceps (10) for treating tissue includes a housing (20) having a shaft (12) affixed thereto which has first and second jaw members (110, 120) attached to a distal end (116) thereof. The forceps (10) also includes an actuator (450) for moving jaw members (110, 120) relative to one another from a first position wherein the jaw members (110, 120) are disposed in spaced relation relative to one another to a second position wherein the jaw members (110, 120) cooperate to grasp tissue (420) therebetween. Each of the jaw members (110, 120) is connected to a source of electro-  
5 surgical energy (300) such that the jaw members (110, 120) are selectively capable of operating in a bipolar mode which enables the jaw members (110, 120) to conduct bipolar energy through tissue (420) held therebetween to treat tissue. The forceps (10) also includes a monopolar element (154) housed within the first jaw member (110) which is selectively movable from a first position within the first jaw member (110) to a second  
10 position distal to the first jaw member (110). The monopolar element is connected to the source of electro-  
15 surgical energy (300) and is selectively activateable independent of the bipolar mode.

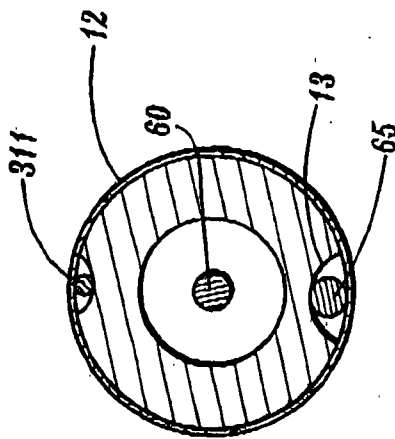

FIG. 1B

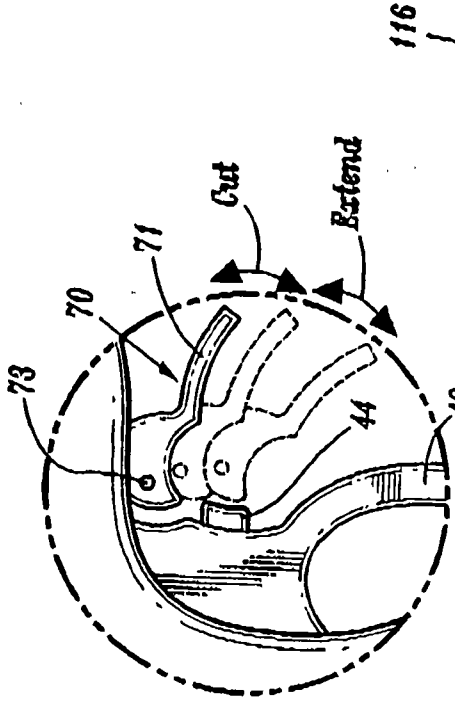

FIG. 1C

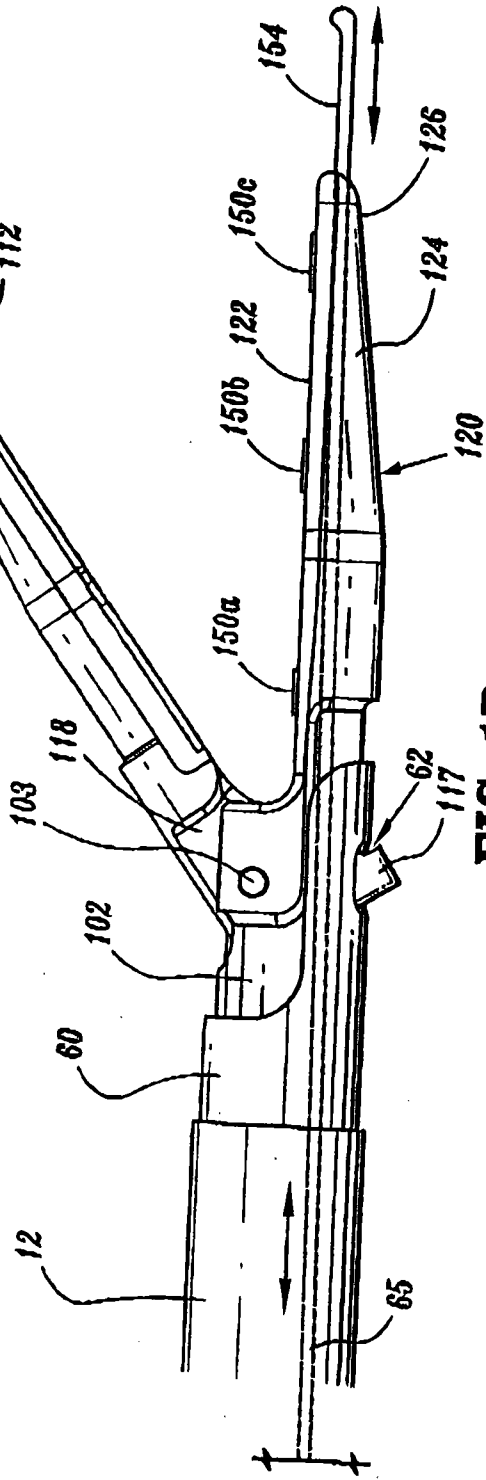

FIG. 1D

2004231188 17 Nov 2004

AUSTRALIA

PATENTS ACT 1990

**COMPLETE SPECIFICATION**

FOR A STANDARD PATENT

---

Name and Address of Applicant :	Sherwood Services AG, of Bahnhofstr.29, 8200, Schaffhausen, Switzerland
Actual Inventor(s):	Kate Lawes Sean T. Dycus
Address for Service:	Spruson & Ferguson St Martins Tower Level 35 31 Market Street Sydney NSW 2000 (CCN 3710000177)
Invention Title:	Bipolar forceps having monopolar extension

The following statement is a full description of this invention, including the best method of performing it known to me/us:-

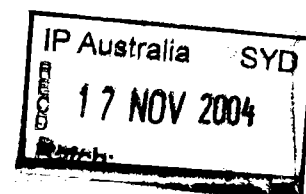

## BIPOLAR FORCEPS HAVING MONOPOLAR EXTENSION

### Field of the Invention

The present disclosure relates to an electrosurgical forceps and more particularly, the present disclosure relates to an endoscopic bipolar electrosurgical forceps for coagulating, sealing and/or cutting tissue having a selectively energizable and/or extendable monopolar extension for enhanced electrosurgical effect.

### Background of the Invention

Electrosurgical forceps utilize both mechanical clamping action and electrical energy to effect hemostasis by heating the tissue and blood vessels to coagulate, cauterize and/or seal tissue. As an alternative to open forceps for use with open surgical procedures, many modern surgeons use endoscopes and endoscopic instruments for remotely accessing organs through smaller, puncture-like incisions. As a direct result thereof, patients tend to benefit from less scarring and reduced healing time.

Endoscopic instruments are inserted into the patient through a cannula, or port, which has been made with a trocar. Typical sizes for cannulas range from three millimeters to twelve millimeters. Smaller cannulas are usually preferred, which, as can be appreciated, ultimately presents a design challenge to instrument manufacturers who must find ways to make endoscopic instruments that fit through the smaller cannulas.

Many endoscopic surgical procedures require cutting or ligating blood vessels or vascular tissue. Due to the inherent spatial considerations of the surgical cavity, surgeons often have difficulty suturing vessels or performing other traditional methods of controlling bleeding, e.g., clamping and/or tying-off transected blood vessels. By utilizing an electrosurgical scissors, the surgeon may cut tissue during a given surgical procedure utilizing a combination of mechanical cutting action and electrosurgical cutting. By utilizing an endoscopic electrosurgical forceps, a surgeon can cauterize, coagulate/desiccate and/or simply reduce or slow bleeding simply by controlling the intensity, frequency and duration of the electrosurgical energy applied through the jaw members to the tissue.

For treating larger vessels, a surgeon may opt to seal the tissue or vessel. Tissue sealing is fundamentally different than simply coagulating or cauterizing vessels. For the purposes herein, "coagulation" is defined as a process of desiccating tissue wherein the tissue cells are ruptured and dried. "Vessel sealing" or "tissue sealing" is defined as the

process of liquefying the collagen in the tissue so that it reforms into a fused mass with limited demarcation between adjacent tissue structures. In order to effectively seal larger vessels (or tissue) two predominant mechanical parameters must be accurately controlled - the pressure applied to the vessel (tissue) preferably about 3 kg/cm<sup>2</sup> to about 16 kg/cm<sup>2</sup> and the gap distance between the electrodes preferably about 0.001 inches to about 0.006 inches. Several examples of endoscopic vessel sealing instruments are disclosed in commonly-owned U.S. Patent Application Nos. 10/116,944, 10/179,863, 10/369,894 and 10/180,926 and PCT/US01/11340 the entire contents of all of which are hereby incorporated by reference herein.

Generally, the electrical configuration of electrosurgical forceps can be categorized in two classifications: 1) monopolar electrosurgical forceps; and 2) bipolar electrosurgical forceps. Monopolar forceps utilize one active electrode associated with the clamping end effector and a remote patient return electrode or pad which is attached externally to the patient. When the electrosurgical energy is applied, the energy travels from the active electrode, to the surgical site, through the patient and to the return electrode.

Bipolar electrosurgical forceps utilize two generally opposing electrodes which are disposed on the inner opposing surfaces of end effectors and which are both electrically coupled to an electrosurgical generator. Each electrode is charged to a different electric potential. Since tissue is a conductor of electrical energy, when the effectors are utilized to grasp, seal or cut tissue therebetween, the electrical energy can be selectively transferred through the tissue.

One of the inherent disadvantages to utilizing a bipolar endoscopic forceps for cauterizing, coagulating cutting or sealing vessels and other tissues is the inability of the bipolar forceps to match the benefits or advantages of monopolar instruments (i.e., monopolar instruments have the ability to move through avascular tissue and dissect through narrow tissue planes) necessitating the need for the surgeon to replace the bipolar forceps during surgery to reap the benefits of using the monopolar instrument for certain applications. Likewise, during some monopolar endoscopic applications it may be advantageous to replace the monopolar instrument with a bipolar forceps, e.g., for sealing large tissue structures. For example, during a cholecystectomy the gallbladder is dissected from the liver which would typically entail using an endoscopic monopolar instrument, e.g., electrosurgical blade, electrosurgical pencil, loop electrode, etc. However, during the cholecystectomy procedure there may also be a need to seal the

cystic duct or cystic artery which may require a bipolar vessel sealing instrument necessitating the need to replace the monopolar instrument. The surgeon may need to repeatedly remove the monopolar instrument from the operating cavity to utilize the bipolar instrument and vice versa.

5 Thus there exists a need to develop an instrument which can combine the benefits of both monopolar and bipolar operation thereby reducing the need for the surgeon to substitute instruments during surgical certain procedures.

### Object of the Invention

10 It is an object of the present invention to overcome or ameliorate some of the disadvantages of the prior art, or at least to provide a useful alternative.

### Summary of the Invention

15 The present disclosure at least in a preferred embodiment relates to an endoscopic forceps for treating tissue and includes a housing having a shaft affixed thereto and first and second jaw members attached to a distal end of the shaft. The forceps also preferably includes an actuator for moving jaw members relative to one another from a first position wherein the jaw members are disposed in spaced relation relative to one another to a second position wherein the jaw members cooperate to grasp tissue therebetween. A source of electrosurgical energy is connected to each jaw member such that the jaw members are selectively capable of operating in a bipolar mode which  
20 enables the jaw members to conduct bipolar energy through tissue held therebetween to treat tissue. The forceps also preferably includes a monopolar element housed within at least the first jaw member which is selectively movable from a first position within the first jaw member to a second position distal to the first jaw member. The monopolar element is connected to the source of electrosurgical energy and is selectively activateable  
25 independent of the jaw members.

In one preferred embodiment according to the present disclosure, the forceps includes a knife which is selectively moveable within a knife channel defined within at least one of the first and second jaw members to cut tissue disposed between the first and second jaw members. Advantageously, a knife actuator allows a user to selectively move  
30 the knife to cut tissue disposed between the jaw members. The source of electrosurgical energy carries electrical potentials to each respective jaw member such that the jaw members are capable of conducting bipolar energy through tissue held therebetween to effect a tissue seal.

Advantageously, the knife is designed to initially cut tissue disposed between the first and second jaw members and subsequently extend distally from the jaw members to treat tissue in a monopolar fashion. Preferably, the forceps includes a safety (e.g. a safety circuit or mechanical safety element) which only allows electrical activation of the knife (or monopolar element) when the knife (or monopolar element) is extended from the distal ends of the jaw members. The safety may also deactivate the jaw members through circuitry or utilizing a mechanical safety element.

In one preferred embodiment, the first jaw member and the second jaw member each include an elongated slot which runs in opposition substantially along the respective lengths thereof such that the two opposing elongated slots form the knife channel for reciprocating the knife to divide tissue disposed between the two jaw members.

In another preferred embodiment, the forceps is a vessel sealing forceps and at least one of the jaw members includes at least one non-conductive stop member disposed thereon which controls the distance between the first and second jaw members when tissue is held therebetween. Advantageously, the stop member(s) maintains a gap distance of about 0.001 inches to about 0.006 inches between the jaw members when tissue is compressed between the jaw members.

In yet another preferred embodiment according to the present disclosure, the forceps includes an actuator which operates to both move the knife to cut tissue disposed between jaw members and to extend the knife or a separate monopolar element from the first position within the first jaw member to the second position distal to the first jaw member. In still yet another embodiment according to the present disclosure, the forceps includes an actuator which operates to both move the jaw members relative to one another from the first to second positions to grasp tissue therebetween and to extend the monopolar element from the first position within the first jaw member to the second position distal to the first jaw member.

In another preferred embodiment according to the present disclosure, a first actuator may be designed to operate the jaw members for grasping tissue and a second actuator may be included which operates to extend the monopolar element from the first position within the first jaw member to the second position distal to the first jaw member.

The present disclosure also preferably relates to an endoscopic forceps which includes a housing having a shaft affixed thereto and first and second jaw members attached to a distal end of the shaft. The first jaw member is configured to extend distally relative to the second jaw member. An actuator is included for moving jaw members



relative to one another from a first position wherein the jaw members are disposed in spaced relation relative to one another to a second position wherein the jaw members cooperate to grasp tissue therebetween. The jaw members are connected to a source of electrosurgical energy such that the jaw members are selectively capable of operating in a bipolar mode which enables the jaw members to conduct bipolar energy through tissue held therebetween.

The forceps also preferably includes a control switch which, upon selective activation, deactivates the second jaw member and activates the first jaw member with a first electrical potential. At relatively the same time, the control switch also activates a return electrode or return pad with a different electrical potential which is placed adjacent to the patient to enable the first jaw member to selectively treat tissue in a monopolar fashion. Preferably, a safety is included which limits electrical activation of the control switch to when the jaw members are disposed in the second position.

The present disclosure also preferably relates to an endoscopic forceps which includes a housing having a shaft affixed thereto. The shaft includes first and second jaw members attached to a distal end thereof. Preferably, the first and second jaw members each include a tapered or elongated distal end. The forceps also includes an actuator for moving jaw members relative to one another from a first position wherein the jaw members are disposed in spaced relation relative to one another to a second position wherein the jaw members cooperate to grasp tissue therebetween. A source of electrosurgical energy is connected to each jaw member such that the jaw members are selectively capable of operating in a bipolar mode which enables the jaw members to conduct bipolar energy through tissue held therebetween.

A control switch is also preferably included which, upon selective activation thereof, activates the first jaw member and the second jaw member with a first electrical potential and activates a return electrode with a different electrical potential. The return electrode is preferably placed adjacent to the patient which enables the first and second jaw members to selectively treat tissue in a monopolar fashion. Preferably, the forceps includes a safety which only allows electrical activation of the control switch when the jaw members are disposed in the second position.

In another preferred embodiment of the present disclosure, the actuator is selectively lockable to maintain a closure pressure in the range of about 3 kg/cm<sup>2</sup> to about 16 kg/cm<sup>2</sup> and, preferably, about 7 kg/cm<sup>2</sup> to about 13 kg/cm<sup>2</sup> between the jaw members which is advantageous in producing effective and reliable tissue seals. In yet

another embodiment, the forceps may also include a rotating assembly for rotating the jaw members about a longitudinal axis defined through the shaft. Advantageously, the forceps includes a unilateral jaw assembly, i.e., the first jaw member is movable relative to the second jaw member and the second jaw member is substantially fixed. Alternatively, the forceps may include a bilateral jaw assembly, i.e., both jaw members move relative to one another.

Preferably, a spring is included with the actuator or drive assembly to facilitate actuation of the movable handle and to assure the closure force is maintained within a working range of about  $3\text{kg/cm}^2$  to about  $16\text{kg/cm}^2$ .

The present disclosure also preferably relates to a method for treating tissue with electrosurgical energy from an electrosurgical generator which includes the steps of: providing an endoscopic forceps including a housing having a shaft affixed thereto. The shaft includes first and second jaw members attached to a distal end thereof. An actuator is included for moving jaw members relative to one another from a first position wherein the jaw members are disposed in spaced relation relative to one another to a second position wherein the jaw members cooperate to grasp tissue therebetween. A monopolar element is also included which is housed within at least the first jaw member and selectively movable from a first position within the first jaw member to a second position distal to the first jaw member. A return electrode is provided and placed in contact with patient tissue.

The method also preferably includes the steps of: connecting to each jaw member, the monopolar element and the return electrode to the electrosurgical generator; grasping tissue between the jaw members; selectively activating the jaw members to treat tissue disposed between the jaw members in a bipolar fashion; and selectively activating the monopolar element and the return electrode independent of the jaw members to treat tissue in a monopolar fashion.

Preferably, after the step of selectively activating the jaw members to treat tissue, the method includes the step of: extending the monopolar element from the distal end of the jaw members. Advantageously, the step of selectively activating the monopolar element includes deactivating the jaw members.

After the step of selectively activating the jaw members to treat tissue, the method may include the step of: releasing the tissue from the jaw members.

### Brief Description of the Drawings

A preferred embodiment of the invention will now be described, by way of example only, with reference to the accompanying drawings, wherein:

Fig. 1A is a side view of an endoscopic forceps showing a housing, a shaft, an end effector assembly and a trigger assembly in a first position according to an embodiment of the present disclosure;

Fig. 1B is an enlarged, cross section taken along line 1B-1B of Fig. 1A;

Fig. 1C is an enlarged, side view of the trigger assembly of Fig. 1A;

Fig. 1D is an enlarged, side view of the embodiment of an end effector assembly of Fig. 1A showing relative extension of a monopolar element from a distal end of the end effector assembly;

Fig. 2 is a side view of the trigger assembly in a second position for advancing a knife within the end effector assembly;

Fig. 3 is a side view of the trigger assembly in a third position for extending a monopolar element from a distal end of the end effector assembly;

Fig. 4 is a side view of an alternate embodiment of the present invention showing a second actuator advancing the monopolar element relative to the distal end of the end effector assembly;

Fig. 5A is an enlarged, side schematic view of one embodiment of an end effector assembly showing relative movement of a first jaw member relative to a second jaw member prior to advancement of the knife through the end effector assembly;

Fig. 5B is an enlarged, side schematic view of the end effector assembly showing relative movement of the knife through the end effector assembly to divide tissue;

Fig. 5C is an enlarged, side schematic view of the end effector assembly showing relative movement of the knife extending from the distal end of the end effector assembly;

Fig. 6A is an enlarged, side schematic view of another embodiment of an end effector assembly showing a first jaw member extending beyond a second jaw member;

Fig. 6B is schematic view of another embodiment of an end effector assembly showing a series of electrical connections to a control switch and a generator to enable both bipolar activation and monopolar activation; and

Fig. 6C is a table showing the various modes of operation of the forceps utilizing the end effector configuration of Fig. 6B.

### Detailed Description of the Preferred Embodiments

Turning now to Figs. 1A - 1D, one embodiment of an endoscopic forceps 10 is shown for use with various surgical procedures. For the purposes herein, a vessel sealing forceps is shown and described, however, it is envisioned that other types of forceps or scissors may be utilized which both treat tissue for cauterization, coagulation or other purposes and which may be configured for monopolar applications as described herein. Moreover, although the figure drawings depict a forceps 10 for use in connection with endoscopic surgical procedures, the present disclosure may be used for more traditional open surgical procedures. For the purposes herein, the forceps 10 is described in terms of an endoscopic instrument, however, it is contemplated that an open version of the forceps 10 may also include the same or similar operating components and features as described below.

Forceps 10 generally includes a housing 20, a handle assembly 30, a rotating assembly 80, a trigger assembly 70 and an end effector assembly 100 which mutually cooperate to grasp, treat and divide tissue. For the purposes herein, the handle assembly 30, rotating assembly, trigger assembly 70 and end effector assembly 100 are only generally described. A more detailed explanation of all of these cooperating elements are described in commonly owned, co-pending U.S. Patent Application Serial No. 10/460,926 the entire contents of which is hereby incorporated by reference herein.

Forceps 10 includes a shaft 12 which has a distal end 16 dimensioned to mechanically engage the end effector assembly 100 and a proximal end 14 which mechanically engages the housing 20. In the drawings and in the descriptions which follow, the term "proximal", as is traditional, will refer to the end of the forceps 10 which is closer to the user, while the term "distal" will refer to the end which is further from the user. Details of how the shaft 12 connects to the end effector assembly 100 and how the proximal end connects to the housing 20 are explained in the above-mentioned commonly owned, co-pending U.S. Patent Application Serial No. 10/460,926.

As best seen in Fig. 1A, forceps 10 also includes an electrosurgical cable 310 which connects the forceps 10 to a source of electrosurgical energy, e.g., a generator 300. Cable 310 is internally divided into cable leads 310a, 310b and 310c which each transmit electrosurgical energy through their respective feed paths through the forceps 10 to the end effector assembly 100 as explained in more detail with respect to U.S. Patent Application Serial No. 10/460,926. Preferably, generators such as those sold by

Valleylab - a division of Tyco Healthcare LP, located in Boulder Colorado are used as a source of electrosurgical energy, e.g., FORCE EZ™ Electrosurgical Generator, FORCE FX™ Electrosurgical Generator, FORCE 1C™ Electrosurgical Generator, FORCE 2™ Electrosurgical Generator, SurgiStat™ II Electrosurgical Generator. One such system is described in commonly-owned U.S. Patent No. 6,033,399 the entire contents of which are hereby incorporated by reference herein. Other systems have been described in commonly-owned U.S. Patent No. 6,187,003 the entire contents of which is also incorporated by reference herein.

Preferably, the generator 300 includes various safety and performance features including isolated output, independent activation of accessories. Preferably, the electrosurgical generator 300 includes Valleylab's Instant Response™ technology which provides an advanced feedback system to sense changes in tissue 200 times per second and adjust voltage and current to maintain appropriate power.

Handle assembly 30 includes a fixed handle 50 and a movable handle 40. Fixed handle 50 is integrally associated with housing 20 and handle 40 is movable relative to fixed handle 50. Rotating assembly 80 is preferably integrally associated with the housing 20 and is rotatable approximately 180 degrees in either direction about a longitudinal axis "A". Details of the handle assembly 30 and the rotating assembly 80 are described in more detail with respect to U.S. Patent Application Serial No. 10/460,926.

As mentioned above, end effector assembly 100 is attached at the distal end of shaft 12 and includes a pair of opposing jaw members 110 and 120. Movable handle 40 of handle assembly 30 is ultimately connected to an internally disposed drive assembly (not shown) which, together, mechanically cooperate to impart movement of the jaw members 110 and 120 from an open position wherein the jaw members 110 and 120 are disposed in spaced relation relative to one another, to a clamping or closed position wherein the jaw members 110 and 120 cooperate to grasp tissue therebetween.

Turning now to the more detailed features of one embodiment of the present disclosure as described with respect to Figs. 1A - 3, movable handle 40 includes an aperture 42 defined therethrough which enables a user to grasp and move the handle 40 relative to the fixed handle 50. More particularly, handle 40 is selectively moveable about a pivot (not shown) from a first position relative to fixed handle 50 to a second position in closer proximity to the fixed handle 50 which imparts movement of the jaw members 110 and 120 relative to one another.

The lower end of the movable handle 40 includes a flange 90 which, upon movement of the handle 40 proximally, is reciprocated within fixed handle 50. Flange 90 rides within a predefined channel (not shown) disposed within fixed handle 50 to lock the movable handle 40 relative to the fixed handle 50.

5 As best shown in Fig. 1C, a locking flange 44 is disposed on the outer periphery of the handle 40 above the upper portion of the handle 40. Locking flange 44 prevents the trigger assembly 70 from firing when the handle 40 is oriented in a non-actuated position, i.e., the jaw members 110 and 120 are open. As can be appreciated, this prevents accidental or premature severing of tissue prior to completion of a tissue seal.

10 As explained in detail in co-pending U.S. Patent Application Serial No. 10/460,926, movable handle 40 is designed to provide a distinct mechanical advantage over conventional handle assemblies due to the unique position of the pivot point relative to the longitudinal axis "A" of the shaft 12. In other words, by positioning the pivot point above the driving element, the user gains lever-like mechanical advantage to actuate the  
15 jaw members 110 and 120 enabling the user to close the jaw members 110 and 120 with lesser force while still generating the required forces necessary to effect a proper and effective tissue seal. It is also envisioned that the unilateral design of the end effector assembly 100 will also increase mechanical advantage.

20 As best seen in Figs. 1A and 1D, the end effector assembly 100 includes opposing jaw members 110 and 120 which cooperate to effectively grasp tissue for sealing purposes. The end effector assembly 100 is designed as a unilateral assembly, i.e., jaw member 120 is fixed relative to the shaft 12 and jaw member 110 pivots about a pivot pin 103 to grasp tissue.

25 More particularly, the unilateral end effector assembly 100 includes one stationary or fixed jaw member 120 mounted in fixed relation to the shaft 12 and pivoting jaw member 110 mounted about a pivot pin 103 attached to the stationary jaw member 120. A reciprocating sleeve 60 is slidingly disposed within the shaft 12 and is remotely operable by the drive assembly (not shown) which cooperates with handle 40 as explained above to open and close the jaw members 110 and 120. The pivoting jaw member 110  
30 includes a detent or protrusion 117 which extends from jaw member 110 through an aperture 62 disposed within the reciprocating sleeve 60 (Fig. 1D). The pivoting jaw member 110 is actuated by sliding the sleeve 60 axially within the shaft 12 such that aperture 62 abuts against the detent 117 on the pivoting jaw member 110. Pulling the sleeve 60 proximally closes the jaw members 110 and 120 about tissue grasped

therebetween and pushing the sleeve 60 distally opens the jaw members 110 and 120 for approximating and grasping purposes.

Once actuated, handle 40 moves in a generally arcuate fashion towards fixed handle 50 about the pivot point which forces the driving flange (not shown) proximally against the drive assembly (not shown) which, in turn, pulls reciprocating sleeve 60 in a generally proximal direction to close jaw member 110 relative to jaw member 120. Moreover, proximal rotation of the handle 40 causes the locking flange 44 to release, i.e., "unlock" the trigger assembly 70 for selective actuation. These features are shown and explained in detail with reference to commonly-owned, co-pending U.S. Application 10/460,926.

As best illustrated in Figs. 5A-5C, a knife channel 115a and 115b runs through the center of the jaw members 110 and 120, respectively, such that a blade 185 can cut tissue grasped between the jaw members 110 and 120 when the jaw members 110 and 120 are in a closed position. More particularly, the blade 185 can only be advanced through the tissue when the jaw members 110 and 120 are closed thus preventing accidental or premature activation of the blade 185 through tissue. Put simply, the knife channel 115 (made up of half channels 115a and 115b) is blocked when the jaws members 110 and 120 are opened and aligned for distal activation when the jaw members 110 and 120 are closed.

As best shown in Fig. 1D, jaw member 110 includes a jaw housing 116 which has an insulative substrate or insulator 114 and an electrically conductive surface 112. Insulator 114 is preferably dimensioned to securely engage the electrically conductive sealing surface 112. This may be accomplished by stamping, by overmolding, by overmolding a stamped electrically conductive sealing plate, by overmolding a metal injection molded seal plate and/or other ways known in the art. It is envisioned a trigger lead 311 from switch 200 electrically connects to the seal plate 112.

All of these manufacturing techniques produce jaw member 110 having an electrically conductive surface 112 which is substantially surrounded by an insulating substrate 114. The insulator 114, electrically conductive sealing surface 112 and the outer, non-conductive jaw housing 116 are preferably dimensioned to limit and/or reduce many of the known undesirable effects related to tissue sealing, e.g., flashover, thermal spread and stray current dissipation.

As best seen in Fig. 1D, jaw member 110 also includes a pivot flange 118 which includes protrusion 117. Protrusion 117 extends from pivot flange 118 and includes an

arcuately-shaped inner surface dimensioned to matingly engage the aperture 62 of sleeve 60 upon retraction thereof. Pivot flange 118 is also dimensioned to engage pivot pin 103 to allow jaw member 110 to rotate relative to jaw member 120 upon retraction of the reciprocating sleeve 60. Pivot pin 103 also mounts to the stationary jaw member 120 within a proximal portion of jaw member 120.

Preferably, the electrically conductive surface 112 and the insulator 114, when assembled, form the longitudinally-oriented knife slot 115a defined therethrough for reciprocation of the knife blade 185. As mentioned above, knife channel 115a cooperates with corresponding knife channel 115b defined in stationary jaw member 120 to facilitate longitudinal translation of the knife blade 185 along a preferred cutting plane to effectively and accurately separate tissue along the formed tissue seal.

Jaw member 120 includes similar elements to jaw member 110 such as jaw housing 126 having an insulator 124 and an electrically conductive sealing surface 122 which is dimensioned to securely engage the insulator 124. Likewise, the electrically conductive surface 122 and the insulator 124, when assembled, include longitudinally-oriented channel 115b defined therethrough for reciprocation of the knife blade 185. As mentioned above, when the jaw members 110 and 120 are closed about tissue 420, knife channels 115a and 115b form a complete knife channel 115 to allow longitudinal translation of the knife 185 in a distal fashion to sever tissue along the tissue seal.

As mentioned above, jaw member 120 may include a series of stop members 150a-150c preferably disposed on the inner facing surfaces of the electrically conductive sealing surface 122 to facilitate gripping and manipulation of tissue and to define a gap "G" (Fig. 5A) between opposing jaw members 110 and 120 during sealing and cutting of tissue. It is envisioned that the series of stop members 150a-150c may be employed on one or both jaw members 110 and 120 depending upon a particular purpose or to achieve a desired result. A detailed discussion of these and other envisioned stop members 150a-150c as well as various manufacturing and assembling processes for attaching and/or affixing the stop members 150a-150c to the electrically conductive sealing surfaces 112, 122 are described in commonly-assigned, co-pending U.S. Application Serial No. PCT/US01/11413 which is hereby incorporated by reference in its entirety herein.

Jaw member 120 is designed to be fixed to the end of a rotating tube (not shown) which is part of the rotating assembly 80 such that rotation of the tube will impart rotation to the end effector assembly 100. Jaw member 120 is connected to a second electrical potential through the rotating tube (not shown) which is connected at its proximal end to a



lead 310c from cable 310. Details relating to the mechanical and electromechanical engagement of the jaw member 120 to the rotating assembly 80 are described in above-mentioned, commonly-owned, co-pending U.S. Patent Application Serial No. 10/460,926.

As mentioned above, the jaw members 110 and 120 may be opened, closed and rotated to manipulate tissue until sealing is desired. This enables the user to position and re-position the forceps 10 prior to activation and sealing. As illustrated in Fig. 1A, the end effector assembly 100 is rotatable about longitudinal axis "A" through rotation of the rotating assembly 80. It is envisioned that the unique feed path of the trigger lead 311 from the switch 200 through the rotating assembly 80, along shaft 12 and, ultimately, to the jaw member 110 enables the user to rotate the end effector assembly 100 about 180 degrees in both the clockwise and counterclockwise direction without tangling or causing undue strain on the cable lead. The other cable lead 310c from cable 310 is fused or clipped to the proximal end of the rotating tube (not shown) and is generally unaffected by rotation of the jaw members 110 and 120. As can be appreciated, this facilitates the grasping and manipulation of tissue.

Again as best shown in Figs. 1A and 1C, trigger assembly 70 mounts atop movable handle 40 and cooperates with the knife assembly 180 (Figs. 2, 3, 4, and 5A-5C) to selectively translate knife 185 through a tissue seal. More particularly, the trigger assembly 70 includes a finger actuator 71 and a pivot pin 73 which mounts the trigger assembly 70 to the housing 20. Finger actuator 71 is dimensioned to abut the locking flange 44 on handle 40 when the handle 40 is disposed in a non-actuated position, i.e., the jaw members 110 and 120 are opened.

The trigger assembly 70 is designed to cooperate with a drive bar 64 which connects to the knife assembly 180. Proximal activation of the finger actuator 71 rotates the trigger assembly 70 about pivot pin 73 which, in turn, forces the drive bar 64 distally, which ultimately extends the knife 185 through tissue. A spring (not shown) may be employed to bias the knife assembly 180 in a retracted position such that after severing tissue the knife 185 and the knife assembly 180 are automatically returned to a pre-firing position. In addition, when the handle 40 is actuated and flange 90 is fully reciprocated within fixed handle 50, the locking flange 44 moves proximally allowing activation of the trigger assembly 70.

As best shown in Fig. 1A, the cable 310 is fed through the bottom of the housing 20 through fixed handle 50. A first lead 310c extends directly from cable 310 into the rotating assembly 80 and connects (via a fused clip or spring clip or the like) to tube 60 to

conduct the second electrical potential to fixed jaw member 120. Second and third leads 310a and 310b extend from cable 310 and connect to the hand switch or joy-stick-like toggle switch 200. Switch 200 permits the user to selectively activate the forceps 10 in a variety of different orientations, i.e., multi-oriented activation which simplifies activation.

5 When the switch 200 is depressed, a trigger lead 311 carries the first electrical potential to jaw member 110. More particularly, the trigger lead 311 extends from switch 200 through the rotating assembly 80 and along the upper portion of the rotating tube (not shown) and eventually connects to the movable jaw member 110. As can be appreciated, locating the switch 200 on the forceps 10 has many advantages. For example, the switch  
10 200 reduces the amount of electrical cable in the operating room and eliminates the possibility of activating the wrong instrument during a surgical procedure due to "line-of-sight" activation.

As explained in detail above, the second electrical potential (i.e., lead 310c) is conducted to jaw member 120 through the rotating tube. The two potentials are  
15 preferably isolated from one another by insulative sheathing (or the like) which surrounds the trigger lead. Preferably, the jaw members 110 and 120 are electrically isolated from one another such that bipolar electrosurgical energy can be effectively transferred through the tissue to form a tissue seal.

Once the desired position for the sealing site is determined and the jaw members  
20 110 and 120 are properly positioned, handle 40 may be compressed fully such that the flange 90 is reciprocated and locked within fixed handle 50. Handle 40 is now secured in position relative to fixed handle 50 which, in turn, locks the jaw members 110 and 120 in a closed position about tissue. The forceps 10 is now ready for selective application of electrosurgical energy and subsequent separation of tissue, i.e., when movable handle 10  
25 reciprocates within fixed handle 50, locking flange 44 moves into a position to permit activation of the trigger assembly 70 as explained above.

As can be appreciated, the combination of the mechanical advantage of the over-the-center pivot along with the assisting compressive forces associated with a compression spring (not shown) facilitate and assure consistent, uniform and accurate  
30 closure pressure about tissue within the desired working pressure range of about 3 kg/cm<sup>2</sup> to about 16 kg/cm<sup>2</sup> and, preferably about 7 kg/cm<sup>2</sup> to about 13 kg/cm<sup>2</sup>. As mentioned above, at least one jaw member, e.g., 120, may include a stop member e.g., 150a, which limits the movement of the two opposing jaw members 110 and 120 relative to one another. Preferably, a series of stop members are to yield a consistent and accurate gap

distance "G" during sealing (Fig. 5A) which ranges from about 0.001 inches to about 0.006 inches and, more preferably, between about 0.002 and about 0.003 inches. By controlling the intensity, frequency and duration of the electrosurgical energy applied to the tissue, the user can effectively seal the tissue along a predetermined tissue site.

5 As energy is being selectively transferred to the end effector assembly 100, across the jaw members 110 and 120 and through the tissue, a tissue seal forms isolating two tissue halves. At this point and with other known vessel sealing instruments, the user must remove and replace the forceps 10 with a cutting instrument (not shown) to divide the tissue halves along the tissue seal which is both time consuming and tedious and may  
10 result in inaccurate tissue division across the tissue seal due to misalignment or misplacement of the cutting instrument along the ideal tissue cutting plane.

The present disclosure incorporates knife assembly 180 which, when activated via the trigger assembly 70, progressively and selectively divides the tissue along an ideal tissue plane in precise manner to effectively and reliably divide the tissue. The knife  
15 assembly 180 allows the user to quickly separate the tissue immediately after sealing without substituting a cutting instrument through a cannula or trocar port. As can be appreciated, accurate sealing and dividing of tissue is accomplished with the same forceps 10.

Once the tissue is divided into tissue halves, the jaw members 110 and 120 may  
20 be opened by re-grasping the handle 40 which release the flange 90 from fixed handle 50. Details relating to the releasing of the flange from handle are described in commonly-owned, co-pending U.S. Application Serial No. 10/460,926.

Turning now to the operating characteristics of the present disclosure and as seen in the majority of the figures, forceps 10 is designed for both bipolar electrosurgical  
25 treatment of tissue (either by vessel sealing as described above or coagulation or cauterization with other similar instruments) and monopolar treatment of tissue. For example, Figs. 1A-D and 2-4 show one embodiment of a forceps 10 which includes a monopolar element 154 which may be selectively extended and selectively activated to treat tissue. Figs. 5A-5C show an alternate embodiment of the present disclosure which  
30 shows that the knife 185 maybe extended from the distal end of the end effector assembly 100 and selectively energized to treat tissue in a monopolar fashion. Fig. 6A shows another embodiment wherein the bottom jaw member 120' extends distally from the top jaw member 110' to allow the surgeon to selectively energize the bottom jaw member 120' and treat tissue in a monopolar fashion. Fig. 6B shows yet another embodiment

wherein the jaw members 110" and 120" include tapered distal ends which are selectively energized with a single electrical potential to treat tissue in a monopolar fashion.

Figs. 1A -1D and 2-4 show one embodiment wherein a monopolar element 154 is housed for selective extension within one jaw member, e.g., jaw member 120, of the end effector assembly 100. More particularly, monopolar element 154 is designed to move independently from knife assembly 180 and may be extended by further proximal movement of the trigger assembly 70 (Fig. 1A, 2 and 3) or by a separate actuator 450 (Fig. 4).

Preferably, the monopolar element 154 is connected to a reciprocating rod 65 which extends through an elongated notch 13 in the outer periphery of the shaft 12 as best seen in Fig. 1B. Drive rod 60 which actuates the knife 185 extends through the inner periphery of shaft 12. In order to extend the monopolar element 154, the jaw members 110 and 120 are initially closed and the knife 185 is advanced distally utilizing the trigger assembly 70 (See Fig. 2). As best shown in Fig. 1C, the trigger 71 is initially advanced to translate the knife 185 distally to cut through tissue, i.e., the "cut" stage (shown in phantom). Thereafter and as shown in Fig. 3, the trigger 71 may be further actuated in a proximal direction to extend the monopolar element 154, i.e., the "extend" stage (shown in phantom).

It is envisioned that the trigger assembly 70 may be designed such that the monopolar element 154 may be extended when the jaw members 110 and 120 are in the open position. For example, the trigger 71 may be moved distally (or upwardly) from its original, rested, neutral or pre-actuated position to advance the monopolar element 154. Alternatively, the monopolar element 154 may be advanced irrespective of the orientation of the jaw members 110 and 120. For example, the trigger assembly 70 could be designed such that the it can be moved laterally (i.e., perpendicular to the longitudinal axis "A") to advance the monopolar element 154 or the trigger assembly 70 could be designed such that the monopolar element 154 is extendible when the trigger 71 is moved to a proximal-most position (i.e., past the "cut" position as described above) and/or when the trigger 71 is advanced distally from the neutral or pre-actuated orientation. A return spring (not shown) may be included to return the monopolar element 154 to a non-extended position upon release of the trigger 71.

Upon extension of the monopolar element 154, the generator 300 is preferably configured to automatically switch the forceps 10 from a bipolar activation mode (i.e., deactivating energy delivery to jaw members 110 and 120) to a monopolar activation

mode (i.e., activating the monopolar element 154). As can be appreciated, the forceps 10 may also (or alternatively) be configured for manual switching between the bipolar activation mode and the monopolar activation mode.

As described above, when the forceps 10 is configured for bipolar operation, the activation of switch 200 transfers energy from jaw member 110 through the tissue and to jaw member 120 to treat tissue. In the monopolar mode, activation of switch 200 (or a separate switch, e.g., a footswitch), transfers energy to the monopolar element 154, through the tissue and to a return electrode 550, e.g., a return pad, placed adjacent to or in contact with the patient. The monopolar activation mode allows the monopolar element 154 to quickly treat avascular tissue structures and/or quickly dissect narrow tissue planes.

As can be appreciated, it is also envisioned that the trigger assembly 70 may be electrically configured to transmit electrical energy to the monopolar element 154 when extended. For example, the trigger assembly 70 may be configured such that proximal-most actuation of the trigger 71 (Fig. 1C) both extends and activates the monopolar element 154. An automatic safety circuit 460 (or mechanical safety lock (not shown)) may be employed which prevents the switch 200 from energizing the jaw members 110 and 120 when the monopolar element 154 is extended.

Fig. 4 shows another embodiment of the present disclosure wherein the monopolar element 154 is selectively extendible utilizing a second actuator 450. As described above, the knife 185 is advanced by actuating the trigger 71 in a generally proximal direction. The monopolar element 154 is selectively advanceable independently of the knife 185 and may be extended when the jaw members 110 and 120 are disposed in either the open configuration or closed configuration. It is envisioned that the actuator 450 may be electrically configured to activate the monopolar element 154 automatically once extended or manually by activation switch 200 or perhaps another switch (not shown). As mentioned above, a safety circuit 460 may be employed to deactivate jaw members 110 and 120 when the monopolar element 154 is extended such that activation of the switch 200 energizes the monopolar element 154. In the case of a separate activation switch for the monopolar element, the safety circuit would deactivate the switch 200.

Fig. 5A-5C show an alternate embodiment of the present disclosure wherein the knife 185 can be extended distally beyond the jaw members 110 and 120 and separately

energized to treat tissue. In this instance, when the knife is extended beyond the jaw members 110 and 120, the knife 185 becomes the monopolar element.

For example and as depicted in the activation sequence shown in Figs. 5A-5C, the knife 185 is initially seated in a neutral position during tissue approximation and grasping and during the sealing process. Once the jaw members 110 and 120 are closed about tissue, the elongated knife channel 115 (defined by upper and lower knife channels 115a and 115b, respectively) is formed to allow selective translation of the knife 185 through tissue disposed between the jaw members 110 and 120. Upon actuation of the trigger 71, the knife bar 64 forces the knife 185 distally through the tissue to the distal end of the knife channel 115. A stop 119 is included to temporarily limit the movement of the knife 185 and provide the user with positive tactile feedback as to the end of the cutting stroke. Upon further actuation of the trigger 71, the knife 185 overcomes the limiting forces associated with the stop 119 and is forced by the knife bar to further extend out of the knife channel 115 and beyond the distal ends of the jaw members 110 and 120.

It is envisioned that once the knife 185 extends beyond the jaw members 110 and 120, a safety or switch deactivates energizing circuitry to the jaw members 110 and 120 and activates the energizing circuitry to the knife 185 such that activation of the switch 200 energizes the knife 185 and the jaw members remain neutral. For example, the stop 119 may act as a safety switch such that upon being forced by the knife 185 out of or away from the knife channel 115, the stop 119 deactivates circuitry to the jaw members 110 and 120 and activates circuitry to the monopolar knife 185 and the return electrode 550. A separate lead 69 may be used to electrically communicate with the generator 300. As can be appreciated, the knife 185 may now be used in a monopolar fashion to treat tissue.

Upon release of the trigger 71, the knife 185 automatically retracts into the knife channel 115 and back to the pre-actuated position as shown in Fig. 5A. At the same time the stop 119 reverts to its original position to temporarily block the knife channel 115 for subsequent actuation.

Fig. 6A shows another embodiment of a forceps 10' according to the present disclosure wherein the lower jaw member 120' is designed to extend beyond the distal end of jaw member 110'. In order to switch from a bipolar mode of the operation to a monopolar mode, the surgeon activates a switch or control which energizes jaw member 120' to a first potential and activates a return pad 550 to a second potential. Energy is

transferred from jaw member 120, through tissue, and to the return pad 550 to treat tissue. The distal end of jaw member 120' acts as the monopolar element for treating the tissue and may be shaped accordingly to enhance electrosurgical effect.

5 Figs. 6B shows yet another schematic embodiment of a forceps 10'' according to the present disclosure wherein the distal ends of both jaw members 110 and 120 are shaped to treat tissue when disposed in a monopolar mode. More particularly, the distal tips 112a'' and 122a'' are preferably elongated or tapered to enhance energy delivery when the forceps 10'' is disposed in the monopolar mode. When disposed in the bipolar mode, the tapered ends 112a'' and 122a'' do not effect treating tissue between electrically  
10 conductive plates 112'' and 122''.

A control switch 500 is preferably included which regulates the transition between bipolar mode and monopolar mode. Control switch 500 is connected to generator 300 via cables 360 and 370. A series of leads 510, 520 and 530 are connected to the jaw members 110, 120 and the return electrode 550, respectively. As best shown in  
15 the table depicted in Fig. 6C, each lead 510, 520, and 530 is provided with an electrical potential or remains neutral depending upon the particular "mode" of the forceps 10''. For example, in the bipolar mode, lead 510 (and, in turn, jaw member 110'') is energized with a first electrical potential and lead 520 (and, in turn, jaw member 120'') is energized with second electrical potential. As a result thereof, electrosurgical energy is transferred  
20 from jaw member 110'' through the tissue and to jaw member 120''. The return electrode 550 remains off or neutral.

In a monopolar mode, jaw member 110'' and 120'' are both energized with the same electrical potential and the return pad 550 is energized with a second electrical potential forcing the electrical current to travel from the jaw members 110'' and 120'',  
25 through the tissue and to the return electrode 550. This enables the jaw members 110'' and 120'' to treat tissue in a monopolar fashion which, as mentioned above, advantageously treats avascular tissue structures and/or allows quick dissection of narrow tissue planes. As can be appreciated, all of the leads 510, 520 and 530 may be deactivated when the forceps 10'' is turned off or idle.

30 Although the general operating components and inter-cooperating relationships among these components have been generally described with respect to a vessel sealing forceps 10, other instruments may also be utilized which can be configured to allow a surgeon to selectively treat tissue in both a bipolar and monopolar fashion. For example,

bipolar grasping and coagulating instruments, cauterizing instruments, bipolar scissors, etc.

The present disclosure also relates to a method for treating tissue with electrosurgical energy from the electrosurgical generator 300 which includes the steps of: providing an endoscopic forceps 10 including a housing 20 having a shaft 12 affixed thereto. The shaft 12 includes first and second jaw members, 110 and 120, respectively, attached to a distal end of the shaft 12. An actuator or handle assembly 30 is included for moving jaw members 110 and 120 relative to one another from a first position wherein the jaw members 110 and 120 are disposed in spaced relation relative to one another to a second position wherein the jaw members 110 and 120 cooperate to grasp tissue therebetween. A monopolar element 154 is also included which is housed within at least the first jaw member 120 and selectively movable from a first position within the first jaw member 120 to a second position distal to the first jaw member 120. A return electrode 550 is provided and placed in contact with patient tissue.

The method also includes the steps of: connecting to each jaw member 110 and 120, the monopolar element 154 and the return electrode 550 to the electrosurgical generator 300; grasping tissue between the jaw members 110 and 120; selectively activating the jaw members 110 and 120 to treat tissue disposed between the jaw members 110 and 120 in a bipolar fashion; and selectively activating the monopolar element 154 and the return electrode 550 independent of the jaw members 110 and 120 to treat tissue in a monopolar fashion.

Preferably, after the step of selectively activating the jaw members 110 and 120 to treat tissue, the method includes the step of: extending the monopolar element 154 from the distal end of the jaw members 110 and 120. Advantageously, the step of selectively activating the monopolar element 154 includes deactivating the jaw members 110 and 120.

After the step of selectively activating the jaw members 110 and 120 to treat tissue, the method may include the step of: releasing the tissue from the jaw members 110 and 120.

From the foregoing and with reference to the various figure drawings, those skilled in the art will appreciate that certain modifications can also be made to the present disclosure without departing from the scope of the same. For example, it may be preferable to add other features to the forceps 10, e.g., an articulating assembly to axially displace the end effector assembly 100 relative to the elongated shaft 12.



It is envisioned that the forceps 10 may be designed such that it is fully or partially disposable depending upon a particular purpose or to achieve a particular result. For example, end effector assembly 100 may be selectively and releasably engageable with the distal end 16 of the shaft 12 and/or the proximal end 14 of shaft 12 may be selectively and releasably engageable with the housing 20 and the handle assembly 30. In either of these two instances, the forceps 10 would be considered "partially disposable" or "reposable", i.e., a new or different end effector assembly 100 (or end effector assembly 100 and shaft 12) selectively replaces the old end effector assembly 100 as needed. As can be appreciated, the presently disclosed electrical connections would have to be altered to modify the instrument to a reposable forceps.

Moreover, it is envisioned that the switch 200 may be decommissioned during the cutting process. Decommissioning the switch 200 when the trigger 71 is actuated eliminates unintentionally activating the forceps during the cutting process. It is also envisioned that the switch 200 may be disposed on another part of the forceps 10, e.g., the fixed handle 40, rotating assembly 80, housing 20, etc.

While several embodiments of the disclosure have been shown in the drawings, it is not intended that the disclosure be limited thereto, as it is intended that the disclosure be as broad in scope as the art will allow and that the specification be read likewise. Therefore, the above description should not be construed as limiting, but merely as exemplifications of preferred embodiments. Those skilled in the art will envision other modifications within the scope and spirit of the claims appended hereto.

**The claims defining the invention are as follows:**

1. An endoscopic forceps, comprising:
  - a housing having a shaft affixed thereto, the shaft including first and second jaw members attached to a distal end thereof;
  - 5 an actuator for moving jaw members relative to one another from a first position wherein the jaw members are disposed in spaced relation relative to one another to a second position wherein the jaw members cooperate to grasp tissue therebetween;
  - a source of electrosurgical energy connected to each jaw member such that the jaw members are selectively capable of operating in a bipolar mode which enables the
  - 10 jaw members to conduct bipolar energy through tissue held therebetween to treat tissue; and
  - a monopolar element housed within at least the first jaw member and selectively movable from a first position within the first jaw member to a second position distal to the first jaw member, the monopolar element being connected to the source of
  - 15 electrosurgical energy and being selectively activateable independent of the jaw members.
2. An endoscopic forceps according to claim 1 wherein the monopolar element includes a sharpened cutting edge.
3. An endoscopic forceps according to claim 1 wherein the forceps
- 20 includes a knife which is selectively moveable within a knife channel defined within at least one of the first and second jaw members to cut tissue disposed between the first and second jaw members.
4. An endoscopic forceps according to claim 1 wherein the forceps is a vessel sealing forceps and at least one of the jaw members includes at least one non-conductive stop member disposed thereon which controls the distance between the first
- 25 and second jaw members when tissue is held therebetween.
5. An endoscopic forceps according to claim 1 wherein the monopolar element is a knife which is selectively moveable within a knife channel defined within at least one of the first and second jaw members to initially cut tissue disposed between the first and second jaw members and subsequently extend distally from the jaw members,
- 30 the knife being energized to treat tissue in a monopolar fashion.
6. An endoscopic forceps according to claim 5 wherein the knife includes a safety which only allows electrical activation of the knife when the knife is extended from the distal ends of the jaw members.

7. An endoscopic forceps according to claim 3 wherein a trigger operates to both move the knife to divide tissue disposed between the jaw members and to extend the monopolar element from the first position within the first jaw member to the second position distal to the first jaw member.

5 8. An endoscopic forceps according to claim 1 wherein the actuator operates to both move the jaw members relative to one another from the first to second positions to grasp tissue therebetween and the actuator operates to extend the monopolar element from the first position within the first jaw member to the second position distal to the first jaw member.

10 9. An endoscopic forceps according to claim 1 further comprising a second actuator which operates to extend the monopolar element from the first position within the first jaw member to the second position distal to the first jaw member.

10. A method for treating tissue with electrosurgical energy from an electrosurgical generator, the method comprising the steps of:

15 providing an endoscopic forceps comprising:

a housing having a shaft affixed thereto, the shaft including first and second jaw members attached to a distal end thereof;

an actuator for moving jaw members relative to one another from a first position wherein the jaw members are disposed in spaced relation relative to one another to a  
20 second position wherein the jaw members cooperate to grasp tissue therebetween;

a monopolar element housed within at least the first jaw member and selectively movable from a first position within the first jaw member to a second position distal to the first jaw member; and

a return electrode placed in contact with patient tissue;

25 connecting to each jaw member, the monopolar element and the return electrode to the electrosurgical generator;

grasping tissue between the jaw members;

selectively activating the jaw members to treat tissue disposed between the jaw members in a bipolar fashion; and

30 selectively activating the monopolar element and the return electrode independent of the jaw members to treat tissue in a monopolar fashion.

11. The method according to claim 10 wherein after the step of selectively activating the jaw members to treat tissue, the method includes the step of:

extending the monopolar element from the distal end of the jaw members.

12. The method according to claim 10 wherein the step of selectively activating the monopolar element includes deactivating the jaw members.

13. The method according to claim 10 wherein after the step of selectively activating the jaw members to treat tissue, the method includes the step of:

5 releasing the tissue from the jaw members.

14. An endoscopic forceps, substantially as herein described with reference to Figs. 1A to 1D, 2 to 4, 5A to 5C and 6A to 6C.

15. A method for treating tissue with electrosurgical energy from an electrosurgical generator, said method substantially as herein described with reference to  
10 Figs. 1A to 1D, 2 to 4, 5A to 5C and 6A to 6C.

**Dated 30 August 2010**

**Covidien AG**

**Patent Attorneys for the Applicant/Nominated Person**

**SPRUSON & FERGUSON**

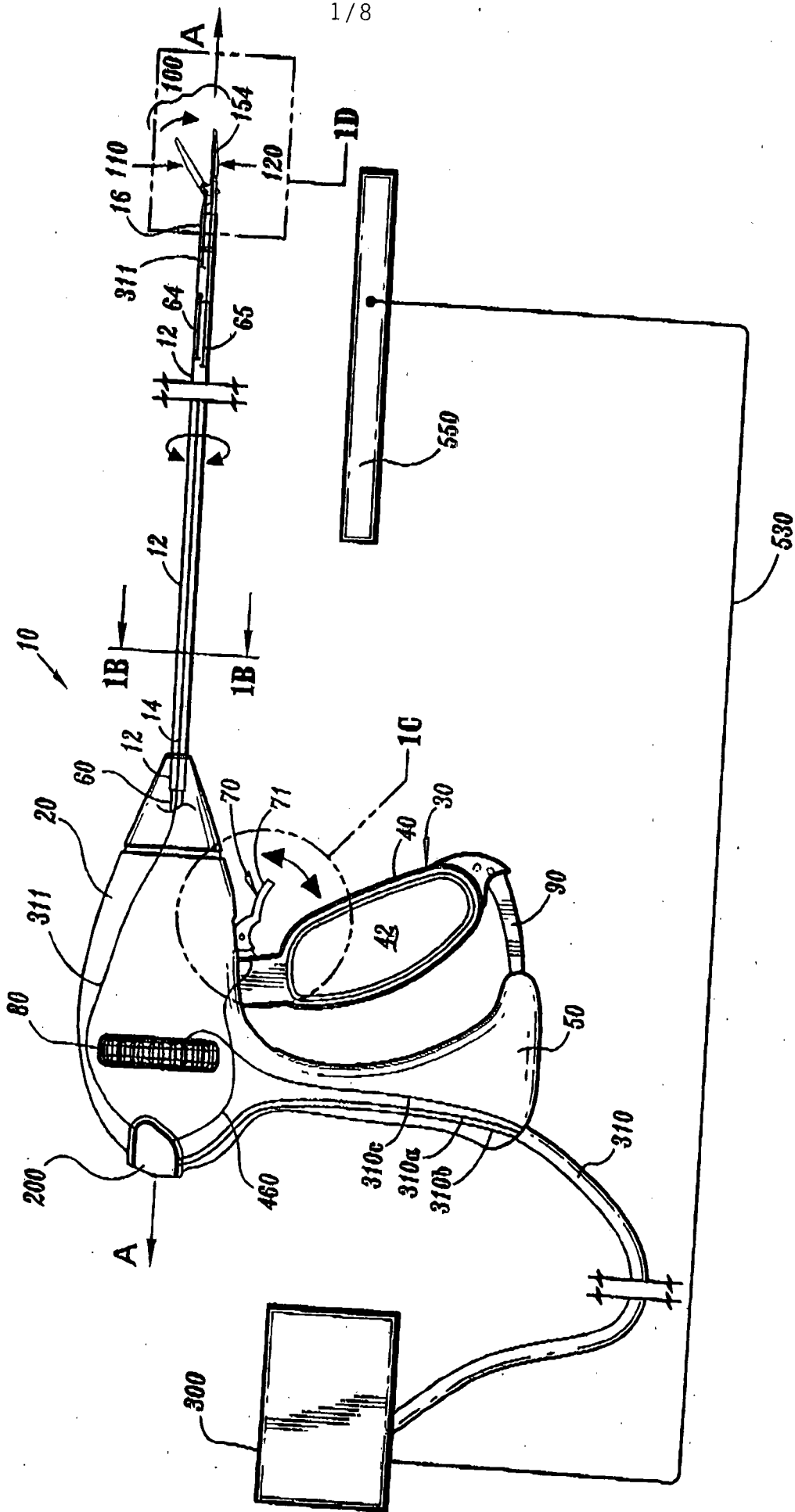

FIG. 1A

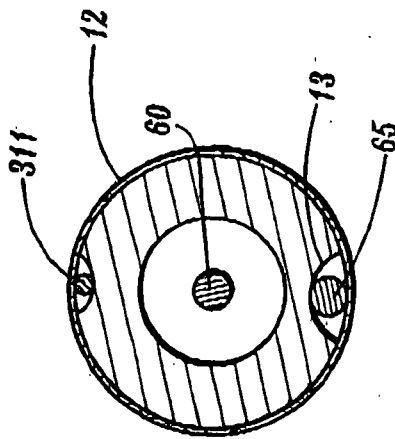

FIG. 1B

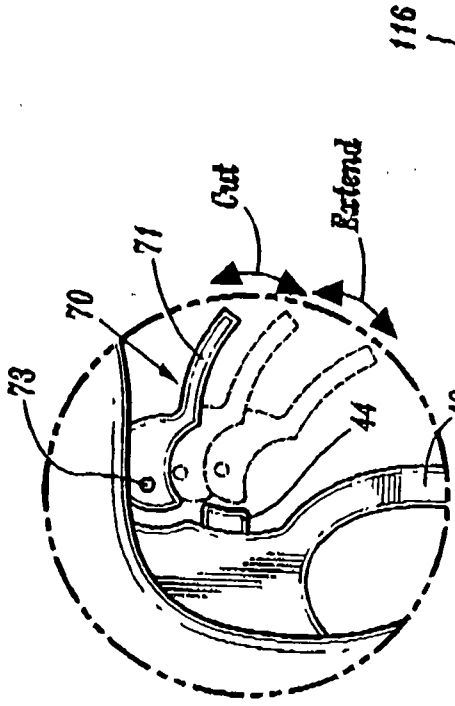

FIG. 1C

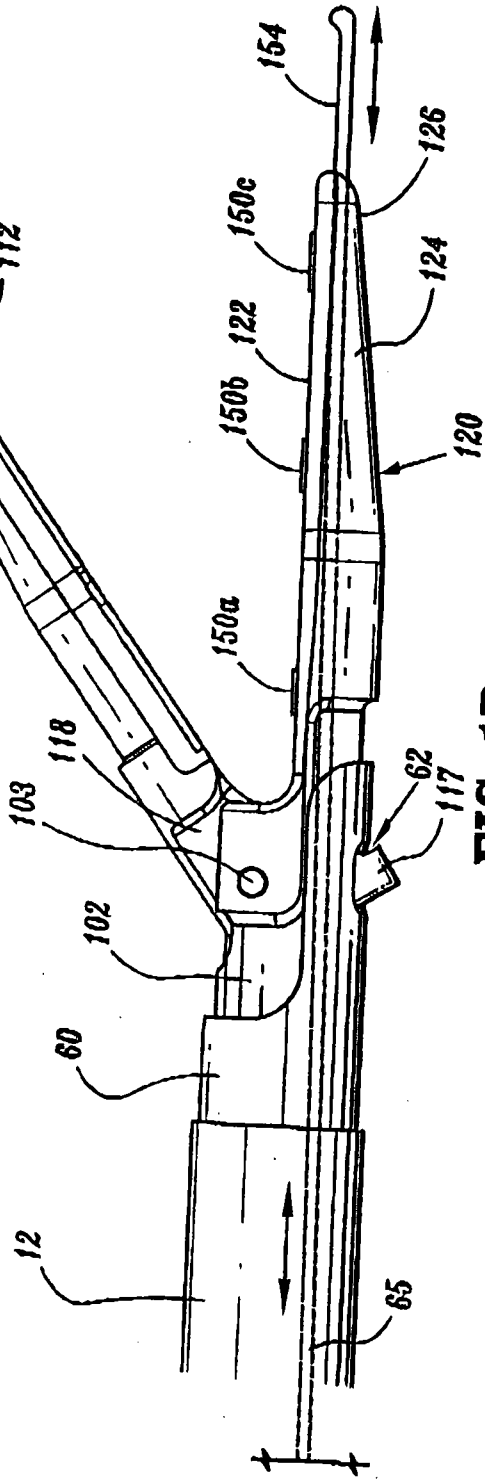

FIG. 1D

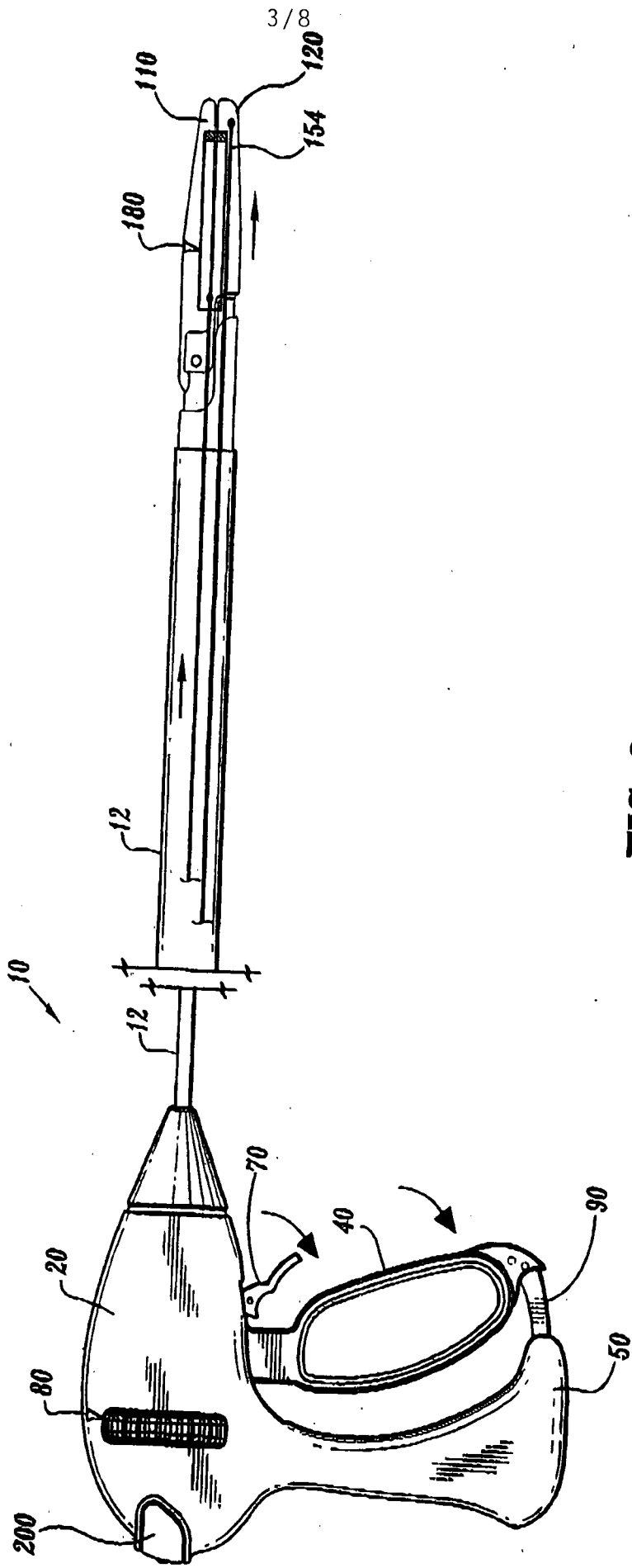

FIG. 2

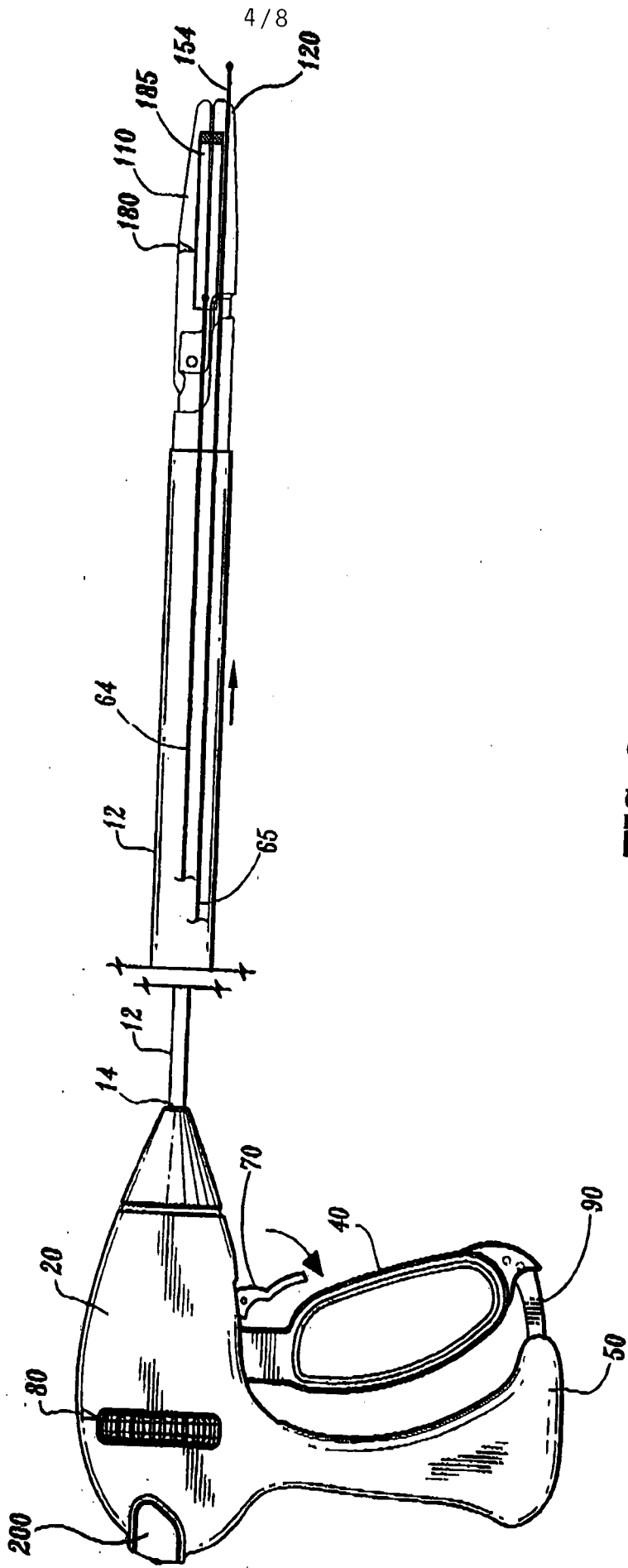

FIG. 3



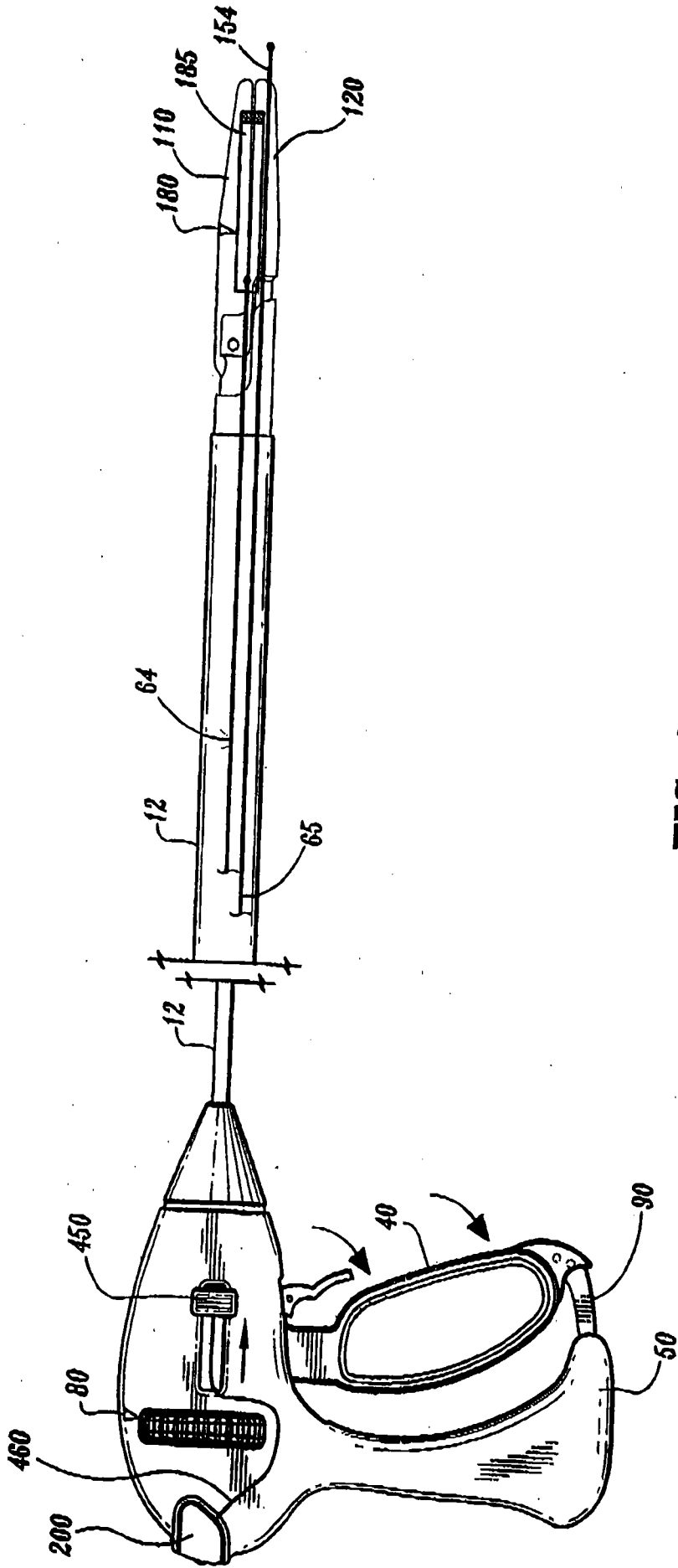
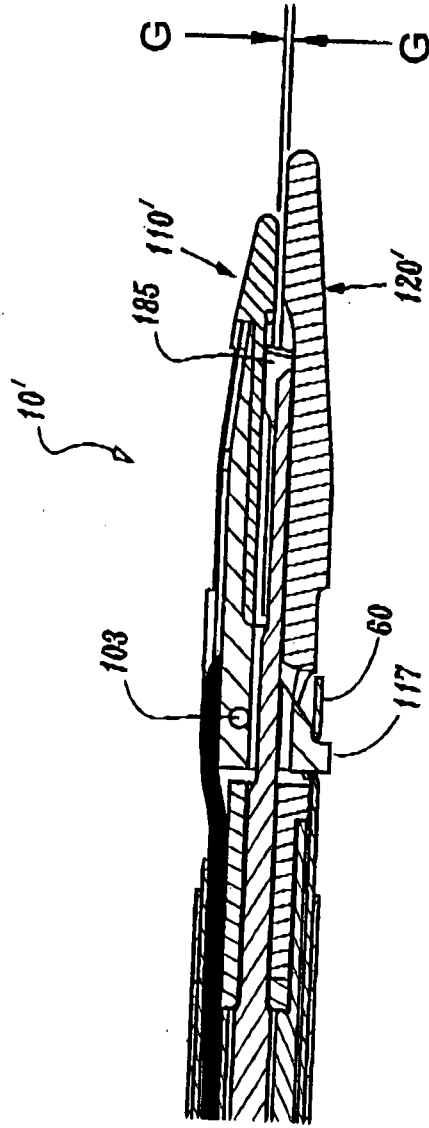

FIG. 4





**FIG. 6A**

Mode	A	B	C
Off	Off	Off	Off
Bi Polar	Off	-	+
Mono Polar	-	+	+

FIG. 6C

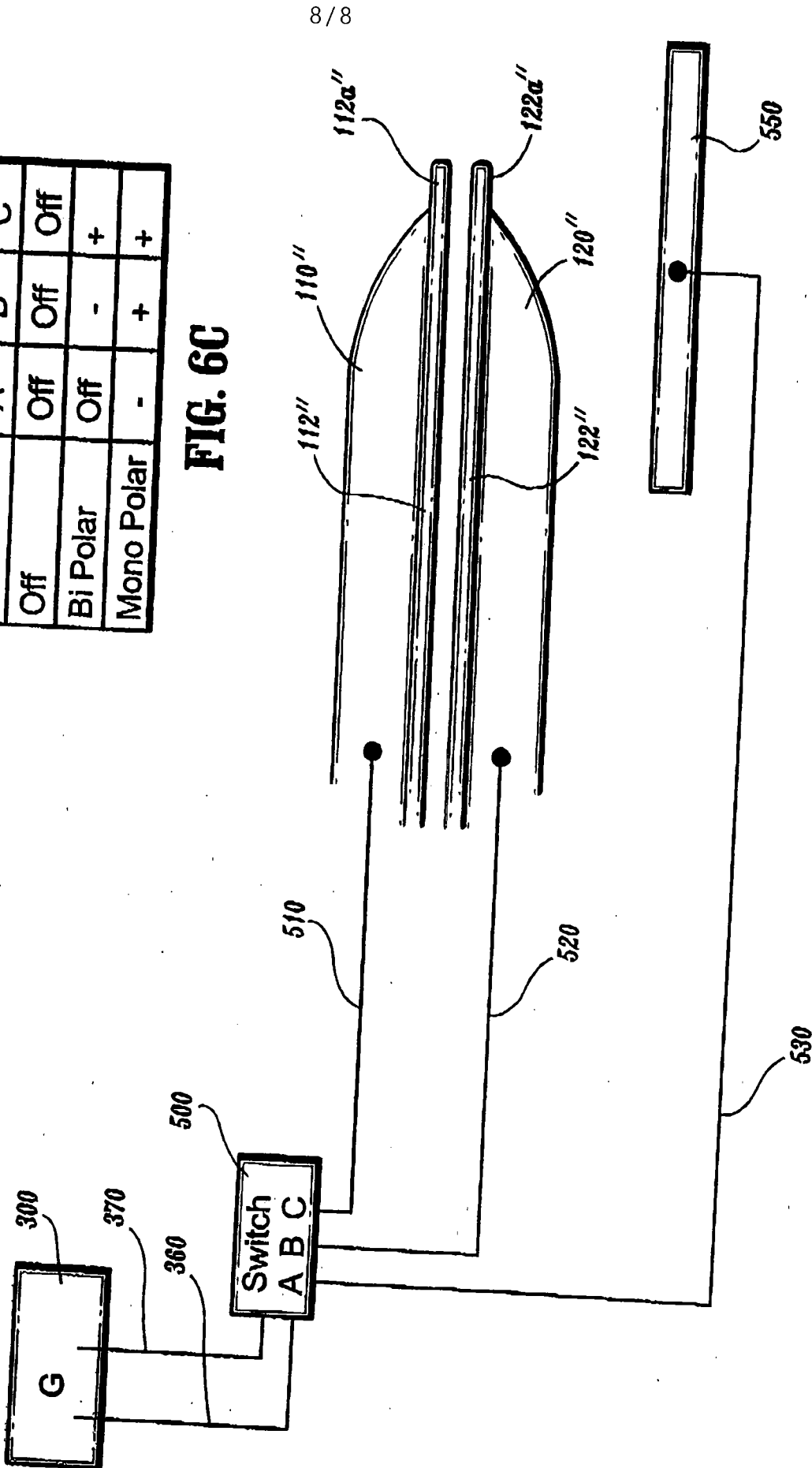

FIG. 6B