



(51) International Patent Classification:

B24B 45/00 (2006.01) B24B 23/00 (2006.01)

(21) International Application Number:

PCT/US2019/020627

(22) International Filing Date:

04 March 2019 (04.03.2019)

(25) Filing Language:

English

(26) Publication Language:

English

(30) Priority Data:

62/638,300 04 March 2018 (04.03.2018) US
62/638,944 05 March 2018 (05.03.2018) US

(71) Applicant: **OSBORN, GMBH** [US/US]; Ringstrasse 10, 35066 Burgwaid (DE).

(72) Inventors: **HANATSCHEK, Heiko**; Dörmholzhäuser Ring 15, 35066 Frankenberg (Eder) (DE). **SCHUSTER, Tim**; Hainstrasse 73, 35066 Frankenberg (Eder) (DE). **BÖHNISCH, Hendrik**; Roder Weg 6, 58809 Neuenrade (DE). **BECKER, Lasse**; Auf Der Burg 10, 35066 Frankenberg (Eder) (DE). **BENDE, Andreas**; Eckeseite 57, 35216 Bledenkopf (DE). **RAIN, Nicoletta**; Querstrasse 7, 35066 Frankenberg (Eder) (DE). **GITE, Atul, M.**; 42, Vish-

wa, Pipeline Road, Sambhaji Nagar, Savedi, Ahmednagar-414003 (IN).

(74) Agent: **STEIN, David, D.**; Boyle Fredrickson, S.C., 840 North Plankinton Avenue, Milwaukee, WI 53203 (US).

(81) Designated States (unless otherwise indicated, for every kind of national protection available): AE, AG, AL, AM, AO, AT, AU, AZ, BA, BB, BG, BH, BN, BR, BW, BY, BZ, CA, CH, CL, CN, CO, CR, CU, CZ, DE, DJ, DK, DM, DO, DZ, EC, EE, EG, ES, FI, GB, GD, GE, GH, GM, GT, HN, HR, HU, ID, IL, IN, IR, IS, JO, JP, KE, KG, KH, KN, KP, KR, KW, KZ, LA, LC, LK, LR, LS, LU, LY, MA, MD, ME, MG, MK, MN, MW, MX, MY, MZ, NA, NG, NI, NO, NZ, OM, PA, PE, PG, PH, PL, PT, QA, RO, RS, RU, RW, SA, SC, SD, SE, SG, SK, SL, SM, ST, SV, SY, TH, TJ, TM, TN, TR, TT, TZ, UA, UG, US, UZ, VC, VN, ZA, ZM, ZW.

(84) Designated States (unless otherwise indicated, for every kind of regional protection available): ARIPO (BW, GH, GM, KE, LR, LS, MW, MZ, NA, RW, SD, SL, ST, SZ, TZ, UG, ZM, ZW), Eurasian (AM, AZ, BY, KG, KZ, RU, TJ, TM), European (AL, AT, BE, BG, CH, CY, CZ, DE, DK, EE, ES, FI, FR, GB, GR, HR, HU, IE, IS, IT, LT, LU, LV, MC, MK, MT, NL, NO, PL, PT, RO, RS, SE, SI, SK, SM, TR), OAPI (BF, BJ, CF, CG, CI, CM, GA, GN, GQ, GW, KM, ML, MR, NE, SN, TD, TG).

(54) Title: ROTARY SURFACE FINISHING IMPLEMENT WITH TOOL MOUNTING ADAPTER

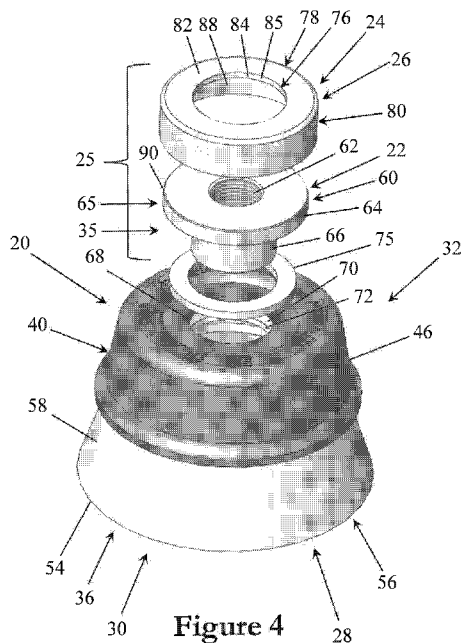

(57) Abstract: A surface finishing implement, such as a wire brush, cup brush, grinding wheel, or cut-off disk, configured for mounting to rotary power tools having a plurality of different types or sizes of mounting arrangements. One implement has a fixed power tool coupling arrangement configured for threadable mounting to a power tool arbor and a removable power tool coupling adapter configured for mounting to a quick-change coupler, preferably one of a quick-connect clamping and twist-lock coupling mechanism, of a power tool. Another implement is configured with a plurality of threaded arbor coupling arrangements configured to enable mounting of the implement to rotary power tools equipped with arbors having different diameters with one of the arbor coupling arrangements being a removable arbor coupling insert that threads into another one of the arbor coupling arrangements fixed to the implement. One implement includes the adapter, removable arbor coupling insert, and fixed arbor coupling arrangement.

WO 2019/173250 A1

Published:

— *with international search report (Art. 21(3))*

ROTARY SURFACE FINISHING IMPLEMENT WITH TOOL MOUNTING ADAPTER

FIELD

[001] The present invention is directed to a rotary surface finishing implement, such as a rotary brush, wheel, or other type of surface finishing, surface treatment or abrasive material removal rotary device, which is adapted to be driven by a rotary power tool, and more particularly to such an implement equipped with a tool mounting adapter that enables removable attachment to rotary power tools having different types and sizes of rotary implement mounting arrangements.

BACKGROUND

[002] Rotary surface treatment implements, such as in the form of rotary brushes, grinding wheels, cut-off discs, and the like, are commonly used in surface treatment applications, including polishing, buffing, sanding, grinding, cutting, and other surface finishing, surface treatment, and abrasive material removal applications. In use, the rotary implement is removably attached via a rotary implement mounting arrangement to an output shaft of a rotary power tool, such as a grinder, e.g., angle grinder, drill, or other type of tool. In operation, the rotary power tool rotates the surface treatment implement at a typical rotational speed of more than one hundred revolutions per minute, or even faster, while the rotating implement engages a surface desired to be treated to polish, buff, sand, grind, abrade, cut, or otherwise treat or finish the surface.

[003] While there are many different types and sizes of rotary implement mounting arrangements employed to facilitate removable attachment of such surface treatment implements to rotary power tools, the power tool commonly employs a male coupling arrangement that engages a female coupling arrangement of the implement to mount the implement to the power tool. One type of common mounting arrangement employs an externally threaded shaft, e.g. an arbor, driven by the power tool that typically requires a tool, such as a wrench, to removably thread it into an internally threaded bore formed in a mounting collar or nut of the implement to removably secure the implement thereto for rotation substantially in unison with the shaft during power tool operation. Because some power tools have larger diameter drive shaft, the diameter of the internally threaded bore of the implement must also be larger to thread it on. Because some power tools have metric shaft diameters with different thread types and some have imperial shaft diameters with different thread types, a rotary surface treatment implement maker must keep in

stock at least three or more different internally threaded mounting collars or nuts for each make and model of rotary surface treatment implement in order to meet demand.

[004] A second type of mounting arrangement employs a rotary implement clamping mechanism carried by the power tool that typically is of toolless construction that has a clamping head inserted into a coupling socket of the implement that is configured to engage part of the implement that forms the socket securely mounting the implement to the tool. Such rotary implement clamping mechanisms are sometimes referred to as quick-change clamps, examples of which are shown and disclosed in US2620604, US5157873A, WO 2019/015980, CH673423A5, and US8317574.

[005] A third type of mounting arrangement employs a twist-lock coupling mechanism carried by the power tool that typically also is of toolless construction that has a keyed or indexed coupling head inserted into the socket of the implement that is rotated or twisted to engage and securely lock the implement to the tool. Examples include twist-lock coupling mechanisms shown and disclosed in US3623281A, US6786811B2, US6869346B2, US6942560B2, US7029384B2, US7722445B2, US7588484B2, and EP1262283B1.

[006] Though the number of different types of rotary implement mounting arrangements employed over the years has lessened, there are nonetheless enough different types and sizes in use to require manufacturers to make multiple sets of the same size rotary implement with at least one set made for use with one type or size of mounting arrangement and at least one other set made for use with another type or size of mounting arrangement. Quite often, it is not unusual for manufacturers to make the same size rotary implement in five or more different mounting sizes.

[007] It is expensive not only to make but also to stock what is essentially the exact same rotary surface treatment implements in multiple different mounting sizes and arrangements in order to satisfy marketplace demand and make it commercially available for all of the rotary power tools with their many different types and sizes of mounting arrangements.

[008] What is needed is a rotary surface treatment implement configured for attachment to rotary power tools having at least one different type or size of mounting arrangement. What also is needed is a rotary surface treatment implement adapter configured to enable mounting of the implement to power tools having at least one different type or size of mounting arrangement.

SUMMARY

[009] The present invention is directed to a rotary surface finishing implement, such as a rotary surface treatment implement, equipped with a plurality of rotary power tool mounting or coupling arrangements including at least one mounting or coupling arrangement configured for threadable receipt of an externally threaded arbor of one rotary power tool, and at least one mounting or coupling arrangement configured for quick-connect coupling with a clamping or twist-lock coupling mechanism of another rotary power tool. In a preferred embodiment, one of the power tool mounting or coupling arrangements is in the form of a removable mounting or coupling adapter. A preferred removable mounting or coupling adapter is configured for quick-connect coupling with a clamping or twist-lock coupling mechanism of a rotary power tool. The present invention also is directed to such a removable mounting or coupling adapter, including such a preferred removable mounting or coupling adapter configured for quick-connect coupling with a clamping or twist-lock coupling mechanism of a rotary power tool.

[010] A preferred rotary surface finishing implement of the present invention is a wire brush, such as a power brush, radial brush, or a cup brush, equipped with a plurality of rotary power tool mounting or coupling arrangements configured to enable the implement to be mountable to rotary power tools having a plurality of different sized and/or types of rotary surface finishing implement mounting mechanisms. One of the mounting or coupling arrangements is a threaded arbor coupling arrangement composed of a collar fixed to the implement that has an internally threaded bore for receiving an externally threaded arbor of a rotary power tool to which the implement can be removably attached. Another one of the mounting or coupling arrangements is a removable mounting or coupling adapter that is removably attached to the threaded arbor coupling arrangement preferably by being removably mounted to the collar. A preferred removable mounting or coupling adapter is configured for quick-connect coupling with a clamping or twist-lock mechanism of a rotary power tool.

[011] A preferred removable mounting or coupling adapter is composed of a quick-connect clamping or twist-lock coupling socket formed of a socket sidewall removably attached to the collar and which carries a generally planar socket anchor plate overlying the collar that has a socket opening formed therein. In one preferred embodiment, the socket opening formed in the plate is generally circular defining a socket configured for receiving a clamping head of a quick-connect clamp of a rotary power tool. In another preferred embodiment, the socket opening

formed in the plate is non-circular defined by an inner peripheral edge having a plurality of spaced apart recesses, defining twist-lock coupling head key receiving keyways, and a plurality spaced apart projections, defining twist-lock coupling head keyway receiving keys.

[012] Where it is desired for the implement to be configured with mounting or coupling arrangements that enable mounting to rotary power tools having arbor shafts of different diameters, the implement can be further equipped with a removable collar insert having an enlarged head from which elongate tube defined by a cylindrical sidewall axially extends that is internally threaded, for threadably receiving an arbor shaft of a power tool, and externally threaded, so it can be threadably received in the internally threaded bore of the collar fixed to the implement. When the removable collar insert is threaded into the fixed collar, the stacked or nested collars define an arbor diameter size adjustable rotary power tool coupling assembly of the of the present invention to which such a removable mounting or coupling adapter can be removably attached.

[013] The result is a rotary surface finishing implement and removable adapter of the present invention mountable to rotary power tools, such as angle grinders, drills, and the like, having different types of mounting or coupling arrangements as well as different diameters of externally threaded arbors. This advantageously enables rotary finishing implements to be made having fewer types of fixed collars and fewer type of quick-connect mounting or coupling arrangements.

[014] Various other features, advantages, and objects of the present invention will be made apparent from the following detailed description and any appended drawings.

DRAWING DESCRIPTION

[015] One or more preferred exemplary embodiments of the invention are illustrated in the accompanying drawings in which like reference numerals represent like parts throughout and in which:

[016] Figure 1 is a top perspective view of a surface treatment implement, e.g., cup brush, equipped with a preferred embodiment of a detachable rotary power tool mounting adapter of the present invention configured with a power tool coupling arrangement for operatively coupling with a quick-change clamping mechanism of a rotary power tool enabling the implement to be relatively quickly removably and toollessly attached to and/or detached from the tool;

[017] Figure 2 is side elevation view of the implement and detachable power tool mounting adapter of Figure 1;

[018] Figure 3 is cross-section of the implement and detachable power tool adapter of Figure 1 taken through section A—A of Figure 2;

[019] Figure 4 is an exploded view of the implement and detachable power tool adapter of Figure 1;

[020] Figure 5 is a bottom perspective view of another embodiment of a surface treatment implement that is a twisted-knot cup brush equipped with a removable power tool mounting adapter constructed in accordance with the present invention;

[021] Figure 6 illustrates a surface treatment implement carrying another preferred embodiment of a removable rotary power tool mounting adapter configured for operatively coupling with a quick-disconnect twist-locking coupling mechanism of a rotary power tool enabling the implement to be relatively quickly removably and toollessly attached to and/or detached from the tool;

[022] Figure 7 is a top perspective view of a surface treatment implement, e.g., cup brush, with the rotary power tool mounting adapter removed to show a removable insert configured as a threaded arbor coupling arrangement of one size threadably received in a threaded arbor coupling arrangement of another size fixed to the implement; and

[023] Figure 8 is a bottom perspective view of the removable threaded arbor coupling arrangement insert of Figure 7.

[024] Before explaining one or more embodiments of the invention in detail, it is to be understood that the invention is not limited in its application to the details of construction and the arrangement of the components set forth in the following description or illustrated in any appended drawings. The invention is capable of other embodiments, which can be practiced or carried out in various ways. Also, it is to be understood that the phraseology and terminology employed herein is for the purpose of description and should not be regarded as limiting.

DETAILED DESCRIPTION

[025] Figures 1-5 illustrate a rotary surface finishing implement 20 of the present invention that is equipped with a power tool mounting arrangement 25 composed of at least a plurality of rotary power tool coupling arrangements 22, 24 configured for removable mounting of the implement 20 to at least a plurality of different types and/or sizes of corresponding complementary rotary surface finishing implement coupling arrangements of a rotary power tool (not shown), such as an angle grinder, drill or the like, to removably attach the implement 20 to the tool. In a preferred

embodiment, the rotary surface finishing implement 20 is equipped with at least one coupling arrangement 22 configured to enable removable attachment of the implement to at least one coupling arrangement of a power tool of a corresponding type and/or size, and the implement 20 has a removable tool mounting adapter 26, e.g., adaptor, configured to provide at least one other coupling arrangement 24 that enables removable attachment of the implement to at least one coupling arrangement of a power tool of a different corresponding type and/or size.

[026] The rotary surface finishing implement 20 preferably is a rotary abrasive surface treating implement 28, such as a rotary wire brush 30, like the cup brush 32 depicted in Figures 1-4. With specific reference to Figure 3, the brush 30, e.g., cup brush 32, has a perforate annular metal brush wire anchor hub 34 from which metallic brush wires 36 outwardly extend that are supported by and sandwiched between substantially rigid inner and outer metal brush wire supporting cups 38, 40. As is shown in Figure 3, the hub 34 is coaxial with and sandwiched between the inner and outer cups 38, 40. The hub 34 has a radially extending perforated portion 42 that extends into an annular brush wire guide channel 44 formed between corresponding brush wire supporting sidewalls 46, 48 of the cups 38, 40 from which groups or tufts 50 of wires 36 outwardly extend. The groups or tufts 50 of wires 36 extend from circumferentially spaced through-holes 52 in the perforate portion 42 of the hub 34 outwardly from between the cups 38, 40. The free ends 54 of the wires 36 define a working face 56 of the brush that engages the surface being finished or otherwise treated by the brush during rotation of the brush by the power tool. The brush wires 36 are formed of elongate wire filaments 58, which can be crimped, such as depicted in Figures 1-3, or which can be twisted and knotted, such as the twisted-knot brush wires 36' of the implement 20', preferably rotary brush 30', e.g., cup brush 32', shown in Figure 5.

[027] As previously indicated, a rotary surface finishing implement 20, preferably brush 30, e.g., cup brush 32, of the invention has a power tool mounting arrangement 25 constructed in accordance with the present invention that is composed of at least a plurality of power tool coupling arrangements 22, 24 disposed in operable cooperation with one another and which are configured to independently or separately enable removable mounting of the implement 20 to at least a plurality of different types and/or sizes of corresponding complementary coupling arrangements of a rotary power tool to removably mount the implement 22 to the tool. In other words, a rotary surface finishing implement 20, preferably brush 30, e.g., cup brush 32, of the

present invention is equipped with one coupling arrangement 22 configured to separately and independently enable mounting of the implement 20 to one power tool equipped with one type or size of complementary coupling arrangement, and is equipped with at least one other coupling arrangement 24 configured to separately and independently enable mounting of the implement 20 to another power tool equipped with another different type or size of complementary coupling arrangement.

[028] With specific reference to Figures 3 and 4, one of the power tool coupling arrangements 22 is a threaded arbor power tool coupling arrangement 35 fixed to the implement 20 which includes a power tool coupling collar 60 with an internally threaded bore 62 having a diameter, thread type and thread pitch selected or configured to match a correspondingly externally threaded output shaft or arbor of a power tool (not shown) having an externally threaded output shaft and arbor of the same diameter, thread type and pitch. The collar 60 has an internally threaded elongate bore 62 formed in a head 65 of the collar 60 that defines a radially extending annular abutment flange 64 from which generally axially extends a generally cylindrical shaft anchor tube 66 in the manner depicted in Figure 4. In assembly, the internally threaded arbor shaft anchor tube 66 is received in generally coaxially aligned collar seating openings 68, 70, 72 formed respectively in the inner cup 38, brush wire anchor hub 34, and the outer cup 40 thereby generally coaxially aligning the inner cup 38, hub 34, and outer cup 40 so they are substantially coincident with an axis of rotation and centerline 74 of the implement 20, preferably brush 30, e.g., cup brush 32.

[029] If desired, an annular washer or spacer 75 can be disposed between the flange 64 of the collar 60 and the outer cup 40 with the flange 64 abutting against the spacer 75 sandwiching the spacer 75 between it and the outer cup 40 when assembly of the implement 20, preferably brush 30, e.g., cup brush 32, is completed. If desired, the annular spacer 75 can be a vibration dampener made of an elastomeric material, such as rubber, neoprene, SORBOTHANE, or another suitable viscoelastic polymeric dampening material that helps dampen and/or isolate vibration generated during contact between the brush wires 36 and surface being finished or treated during use of the rotating implement 20, brush 30, e.g., cup brush 32, to finish or treat the surface.

[030] In power tool attachment, the rotary surface finishing implement 20, preferably brush 30, e.g., cup brush 32, is threaded onto the externally threaded arbor of the rotary power tool with

which it will be used to finish or otherwise treat a surface, object or the like with the brush wire face by rapidly rotating the implement 20 at a rotational speed of at least one-hundred revolutions per minute (RPMs) and preferably at least two hundred RPMs. As previously indicated, the arbor of the power tool has a diameter the same as that of the internally threaded bore 62 formed in the collar 60 with the type and pitch of the threads of the externally threaded arbor matching that of the internally threaded bore 62 of the collar 60. Where the implement 20 is a radial brush, such as a power brush, grinding wheel, or cut off disc, a lock nut (not shown) can be threaded onto the end of the arbor extending through and beyond the implement, e.g. radial brush, grinding wheel or cutoff disc, and securely tightened using a spanner or lock nut wrench (also not shown).

[031] To enable a rotary surface finishing implement 20, preferably brush 30, e.g., cup brush 32, to be mountable to a rotary power tool having a type of coupling arrangement different than that of an externally threaded arbor, the implement 20 advantageously is further equipped with a removable tool mounting adapter 26 configured to provide a quick-change coupling arrangement 24 different than the threaded arbor coupling arrangement 22 discussed above. A preferred tool mounting adapter 26 of the present invention has a female quick-change coupling arrangement 24 configured or adapted to releasably couple with a male quick-change coupling arrangement, namely at least one of a quick-connect clamping mechanism and twist-lock coupling mechanism, of a rotary power tool enabling the implement 20 to be attached to such a quick-change coupling mechanism equipped tool. As discussed in more detail below, when the implement 20 is to be mounted via threaded coupling arrangement 22 to a power tool having an externally threaded arbor, the adapter 26 is removed permitting the internally threaded collar 60 of the threaded coupling arrangement 22 to be threaded onto the arbor of the tool. When it is desired to mount the implement 20 to a power tool equipped with a quick-change coupling arrangement, the adapter 26 is either left in place on the implement 20, such as in the quick-change coupling arrangement operating position depicted in Figures 1 and 2, or reattached to the implement 20 such that the adapter 26 is disposed in the operating position shown in Figures 1 and 2.

[032] The female quick-change coupling arrangement 24 of the removable tool mounting adapter 26 has a power tool quick-connect coupling mechanism engaging socket 76 formed in a generally planar quick-change tool engagement plate 78 overlying the collar 60 of threaded coupling arrangement 22 that is attached to the implement 20 by a coupling socket sidewall 80.

In a preferred embodiment, the quick-change tool engagement plate 78 is an annular quick-connect coupling mechanism anchor plate 82 with a socket opening 84 centered on the plate 82 that is configured for receipt of one or more clamping elements (not shown) of a clamping head (not shown) of a quick-connect clamping mechanism (not shown) of a power tool to which the implement 20 is to be removably but securely mounted. As is best shown in Figures 1 and 4, the socket opening 84 is defined by an inner peripheral edge 85 that forms a generally circular socket opening 84. The coupling socket sidewall 80 encircles and extends axially from the anchor plate 82 defining a generally cylindrical adapter mount 86 configured for secure but removable engagement with the implement 20, such as in the manner depicted in Figures 1 and 2.

[033] With reference to Figure 3, a radially inwardly facing surface 88 of the coupling socket sidewall 80 bounds and engages a radially outwardly facing surface 90 of the head 65 of internally threaded arbor shaft coupling collar 60 in a manner that removably but positively, securely and substantially immovably attaches the adapter 26 to the implement 20 by removably attaching the adapter 26 to the head 65 of the collar 60. In one preferred embodiment, one of the inner surface 88 of the coupling socket sidewall 80 and the outer surface 90 of the head 65 of the collar 60 has at least one and preferably a plurality of radially outwardly extending pins or projections (not shown) which are received in corresponding complementary channels (not shown) formed in the other one of the inner surface 88 of the coupling socket sidewall 80 and the outer surface 90 of the head 65 of the collar 60 to releasably and immovably secure the adapter 26 to the implement 20. In another preferred embodiment, the inner surface 88 of the coupling socket sidewall 80 threadably engages the outer surface 90 of the head 65 of the collar 60 enabling secure but removable attachment of the adapter 26 to the implement 20. Where attachment is achieved via threadable engagement, the threads formed in the inner surface 88 of the coupling socket sidewall 80 and the threads formed in the outer surface 90 of the head 65 of the collar 60 are arranged so that torque transmitted from the power tool to the implement 20 during surface treatment or surface finishing using the implement 20 advantageously tightens the adapter 26 on the collar 60. Other arrangements and means for removably yet positively securing the adapter 26 to the collar 60 of the implement 20 are contemplated as being within the scope of the present invention.

[034] In use and operation, one or more clamping elements of a male clamping head of a rotary power tool are inserted into the opening 84 in the quick-connect coupling mechanism engaging

socket 76 and extended radially outwardly relative to the anchor plate 82 until the anchor plate 82 is engaged by the power tool clamping head thereby toollessly releasably securing the implement 20 to the power tool. When it is desired to remove or change the implement 20, the clamping head is manipulated to disengage the power tool clamping head from the clamp anchor plate 82 permitting the clamp elements of the clamping head to be withdrawn from the opening 84 of the quick-connect coupling mechanism engaging socket 76 detaching the clamping head from the socket 76.

[035] Figure 6 illustrates a rotary surface finishing implement 20, preferably brush 30, e.g., cup brush 32, equipped with another preferred embodiment of a removable rotary power tool mounting adapter 26' constructed in accordance with the present invention having a quick-connect coupling mechanism engaging socket 76' configured for receipt and engagement of a twist-lock coupling mechanism having a shape or contour substantially complimentary to that of a twist-lock coupling head (not shown) of a power tool enabling the implement 20 to be removably and toollessly mounted to the tool. Such a twist-lock coupling head receiving socket 76' is defined by a non-circular socket opening 84' formed in the quick-connect twist-lock coupling head anchor plate 82' having an inner peripheral edge 85' with a discontinuous non-straight non-circular contour substantially complementary to that of a non-circular outer peripheral shape of a twist-lock coupling head (not shown) of a power tool to which the implement is mountable. The inner peripheral edge 85' that defines the non-circular opening 84' of the socket 76' is formed of at least a plurality of circumferentially spaced apart recesses 92 that each defines a twist-lock coupling head key-receiving slot or keyway 94 and at least a plurality of circumferentially spaced radial projections 96 that each defines a twist-lock coupling head keyway-receiving tooth or key 98.

[036] With continued reference to Figure 6, socket 76' is formed of a non-circular opening 84' defined by an inner peripheral edge 85' having four equiangularly circumferentially spaced apart radially outwardly extending twist-lock head key-receiving slots or keyways 94 between each pair of which is disposed a pair of spaced apart radially inwardly extending teeth or keys 98. This produces a socket 76' with an opening 84' defined by an inner peripheral edge 85' having a contour substantially the same as a twist-lock coupling head of a power tool configured with four generally equiangularly spaced apart keys (not shown) of a shape or contour substantially complimentary to that of each one of the slots or keyways 94 of the socket 76' between each pair

of which is disposed a pair of spaced apart slots or keyways (also not shown) of a shape or contour substantially complimentary to that of the teeth or keys 98 of the socket 76'.

[037] In use and operation, such a twist-lock power tool coupling head is manipulated until each of its teeth or keys is received in a corresponding one of the slots or keyways 94 formed in the inner peripheral edge 85' of the socket opening 84' and each one of the teeth or keys 98 formed in the inner peripheral edge 85' of the socket opening 84' are received in a corresponding one of the slots or keyways formed in the twist-lock power tool coupling head. Once this occurs, the twist-lock coupling head is inserted through the opening 84' of the socket 76' and twisted or rotated to engage the twist-lock coupling head of the power tool with the quick-connect clamp anchor plate 82' of the adapter 26' of the implement 20 thereby locking the implement 20 the power tool.

[038] Figure 7 illustrates another preferred embodiment of a rotary surface finishing implement 20, preferably rotary wire brush 30, e.g., cup brush 32, of the present invention with the adapter 26 removed to uncover a plurality of stacked or nested rotary power tool coupling arrangements 22a, 22b that can be housed within the adapter 26 with the plurality of stacked or nested rotary power tool coupling arrangements 22a, 22b defining an arbor diameter size adjustable rotary power tool coupling assembly 112 configured to enable secure removable attachment of the implement 20 to rotary power tools having arbors of a plurality of different sized diameters. One of the rotary power tool coupling arrangements 22b is a removable rotary power tool arbor coupling insert 100 that is stacked on or nested with another one of the rotary power tool coupling arrangements 22a that is substantially immovably fixed or grounded to the implement 20. The removable rotary power tool coupling arrangement 22b or insert 100 is configured to enable removable mounting of the implement 20 to one rotary power tool having an arbor shaft of a first diameter when stacked on or nested in the fixed rotary power tool coupling arrangement 22a. The fixed rotary power tool coupling arrangement 22a is configured to enable removable mounting of the implement 20 to another rotary power tool having an arbor shaft of a second diameter larger than the arbor shaft of the first diameter when the removable rotary power tool coupling arrangement 22b or insert 100 is unstacked, detached, removed or disengaged from the fixed rotary power tool coupling arrangement 22a. With additional reference to Figure 8, the removable rotary power tool threaded arbor coupling insert 100 provides a detachable threaded arbor coupling arrangement 35b configured for threadably receiving an externally threaded arbor

of one rotary power tool having a first arbor shaft diameter and which threadably nests in a fixed threaded arbor coupling arrangement 35a configured for threadably receiving an externally threaded arbor of another rotary power tool having a second arbor shaft diameter greater than the first arbor shaft diameter.

[039] As best shown in Figure 8, the removable threaded arbor coupling insert 100 is formed of a threaded arbor shaft anchoring collar 102 having an outwardly extending flange 104 defining an enlarged head 105 at one end of the collar 102 from which axially extends a narrower generally cylindrical tubular internally and externally threaded elongate arbor anchor tube 106. The insert 100 has an internally threaded bore 108 formed in head 105 that extends into arbor shaft anchor tube 106 with the arbor shaft anchor tube 106 having a diameter smaller than the diameter of the internally threaded bore 62 (Figures 1, 3, 4 and 6) formed in the head 65 and the arbor shaft anchor tube 66 of collar 60. The insert 100 has an arbor shaft anchor tube sidewall 110 that is both internally threaded and externally threaded, the sidewall 110 being externally threaded having an outer diameter, e.g., O.D., thread type, and thread pitch substantially the same as or compatible with the inner diameter, e.g. I.D., thread type and thread pitch of the internally threaded bore 62 formed in the head 65 and arbor shaft anchor tube 66 of the fixed collar 60. The externally threads of the arbor shaft anchor tube sidewall 110 of the removable insert 100 enables the threaded arbor shaft anchor tube 106 to be threaded into the threaded bore 62 in the collar 60 until the head 105, e.g., flange 104, of the insert abuts against the head 65, e.g., flange 64, of collar 60. When the arbor shaft anchor tube 106 of the removable insert 100 is threaded into the threaded bore 62 in the fixed collar 62, at least a portion of the arbor shaft anchor tube 106 of the removable insert 100, e.g., detachable collar 102, is generally coaxially received in at least a portion of the arbor shaft anchor tube. When the arbor shaft anchor tube 106 of the removable insert 100 is threaded into the threaded bore 62 in the fixed collar 60 until its head 105 abuts against the head 65 of the collar 60, the collar 60 and insert 100 form an arbor diameter size adjustable rotary power tool coupling assembly 112 configured to enable secure removable attachment of the implement 20 to rotary power tools having arbors of a plurality of different size diameters.

[040] In use and operation, where a multiple power tool mount type or size rotary surface finishing implement 20, preferably rotary wire brush 30, e.g., cup brush 32, constructed in accordance with the present invention is equipped with an arbor diameter size adjustable rotary

power tool coupling assembly 112, the adapter 26 can be detached or otherwise removed to access one or both arbor shaft coupling collars 60, 102 for mounting of the implement 20 to one of a plurality of different rotary power tool having arbor shafts of different diameters. Where the power tool has an arbor shaft of a diameter, thread type and pitch substantially the same as or compatible with the diameter, thread type and thread pitch of the internally threaded bore 108 formed in detachable collar 102, e.g., insert 100, the implement 20 can be mounted to the power tool by threading the arbor shaft into the threaded bore 108 in collar 102. Where the power tool has an arbor shaft of a larger diameter, the detachable collar 102 or insert 100 is removed by unthreading the externally threaded arbor shaft anchor tube 106 from the internally threaded bore 62 formed in the collar 60 immovably fixed or grounded to the implement 20 until the collar 102 or insert 100 disengages therefrom. Thereafter, the implement 20 is mounted to the power tool by threading the larger diameter arbor shaft into the internally threaded bore 62 formed in the fixed collar 60.

[041] The present invention is directed to a rotary surface finishing implement that includes a power tool mounting arrangement adapted for mounting to rotary power tools having a plurality of different types and sizes of mounting arrangements. The power tool mounting arrangement has a plurality of power tool coupling arrangements with one of the power tool coupling arrangements configured for removable mounting of the rotary surface finishing implement to a threaded arbor of a power tool, and another one of the power tool coupling arrangements configured for removable mounting of the rotary surface finishing implement to a quick-connect clamp or twist-lock coupling arrangement. One of the power tool coupling arrangements includes a removable power tool mounting adapter removably attached to the rotary surface finishing implement. The one of the power tool coupling arrangements configured for removable mounting of the rotary surface finishing implement to a threaded arbor of a power tool has a collar with an internally threaded bore. The removable power tool mounting adapter is removably attached the collar with the internally threaded bore.

[042] The removable power tool mounting adapter includes a quick-connect coupling mechanism engaging socket. The one of the power tool coupling arrangements configured for removable mounting of the rotary surface finishing implement to a threaded arbor of a power tool has a collar with an internally threaded bore. The quick-connect coupling mechanism engaging socket is removably attached to the collar with the internally threaded bore. The quick-

connect coupling mechanism engaging socket includes a generally planar anchor plate having a socket opening formed therein with the anchor plate bounded by a coupling socket sidewall. The generally planar anchor plate is annular and the socket opening formed in the anchor plate is generally circular.

[043] The socket opening formed in the anchor plate can be generally non-circular where configured for the coupling head of a twist-lock rotary power tool coupling arrangement. The non-circular socket opening formed in the anchor plate is defined by an inner peripheral edge having a plurality of recesses and a plurality of projections formed therein defining a twist-lock head receiving socket opening.

[044] The one of the power tool coupling arrangements configured for removable mounting of the rotary surface finishing implement to a threaded arbor of a power tool has a collar with an internally threaded bore. The coupling socket sidewall removably engages the collar with the internally threaded bore. The power tool mounting arrangement includes a collar with an internally threaded bore configured for threadably engaging a threaded arbor of a rotary power tool, and a power tool mounting adapter removably attached to the collar, the power tool mounting adapter including a socket configured for engaging with a quick-connect coupling of a rotary power tool. The socket includes a plate with a socket opening formed therein. The socket further includes a sidewall extending from the plate that engages the collar removably attaching the socket to the collar.

[045] The power tool mounting arrangement has a first collar with a first internally threaded bore of a first diameter configured for threadably engaging a threaded arbor of a rotary power tool having a first diameter, and a second collar with a second internally threaded bore of a second diameter that is threadably removably received in the first internally threaded bore of the first collar. Each collar has an enlarged head at one end from which an elongate tube outwardly extends. The elongate tube of one of the collars is formed of a tubular sidewall that is both internally threaded and externally threaded. The rotary surface finishing implement further includes a removable power tool mounting adapter that includes a socket configured for releasably engaging with a quick-connect coupling assembly of a rotary power tool. The socket includes a socket opening formed in a plate carried by a sidewall releasably engaging one of the collars.

[046] The present invention also is directed to a rotary surface finishing implement that includes a power tool mounting arrangement adapted for mounting to rotary power tools having a plurality of different types and sizes of mounting arrangements with one of the mounting arrangements having a collar fixed to the implement and having an internally threaded bore configured for receiving a threaded arbor of a rotary power tool, and another one of the mounting arrangements having a removable adapter having a quick-connect clamp or twist-lock coupling engaging socket for receiving one of a quick-disconnect clamp or twist-lock coupling arrangement of a rotary power tool. The collar includes an enlarged head and a tube extending axially therefrom, and the socket includes a socket sidewall engaged with the head of the collar to releasably mount the adapter thereto. The socket further includes a socket anchor plate carried by the socket sidewall, the socket anchor plate overlying the collar.

[047] Understandably, the present invention has been described above in terms of one or more preferred embodiments and methods. It is recognized that various alternatives and modifications may be made to these embodiments and methods that are within the scope of the present invention. It is also to be understood that, although the foregoing description and drawings describe and illustrate in detail one or more preferred embodiments of the present invention, to those skilled in the art to which the present invention relates, the present disclosure will suggest many modifications and constructions as well as widely differing embodiments and applications without thereby departing from the spirit and scope of the invention. The present invention, therefore, is intended to be limited only by the drawings, written description and claims appended hereto.

CLAIMS

1. A rotary surface finishing implement comprised of a power tool mounting arrangement adapted for mounting to rotary power tools having a plurality of different types and sizes of mounting arrangements.
2. The rotary surface finishing implement of claim 1, wherein the power tool mounting arrangement comprises a plurality of power tool coupling arrangements with one of the power tool coupling arrangements configured for removable mounting of the rotary surface finishing implement to a threaded arbor of a power tool, and another one of the power tool coupling arrangements configured for removable mounting of the rotary surface finishing implement to a quick-connect clamp or twist-lock coupling arrangement.
3. The rotary surface finishing implement of claim 2, wherein one of the power tool coupling arrangements is comprised of a removable power tool mounting adapter removably attached to the rotary surface finishing implement.
4. The rotary surface finishing implement of claim 3, wherein the one of the power tool coupling arrangements configured for removable mounting of the rotary surface finishing implement to a threaded arbor of a power tool comprises a collar with an internally threaded bore.
5. The rotary surface finishing implement of claim 4, wherein the removable power tool mounting adapter is removably attached the collar with the internally threaded bore.
6. The rotary surface finishing implement of claim 3, wherein the removable power tool mounting adapter comprises a quick-connect coupling mechanism engaging socket.
7. The rotary surface finishing implement of claim 6, wherein the one of the power tool coupling arrangements configured for removable mounting of the rotary surface finishing implement to a threaded arbor of a power tool comprises a collar with an internally threaded bore.

8. The rotary surface finishing implement of claim 7, wherein the quick-connect coupling mechanism engaging socket is removably attached to the collar with the internally threaded bore.
9. The rotary surface finishing implement of claim 6, wherein the quick-connect coupling mechanism engaging socket is comprised of a generally planar anchor plate having a socket opening formed therein with the anchor plate bounded by a coupling socket sidewall.
10. The rotary surface finishing implement of claim 9, wherein the generally planar anchor plate is annular and the socket opening formed in the anchor plate is generally circular.
11. The rotary surface finishing implement of claim 9, wherein the socket opening formed in the anchor plate is generally non-circular.
12. The rotary surface finishing implement of claim 11, wherein the non-circular socket opening formed in the anchor plate is defined by an inner peripheral edge having a plurality of recesses and a plurality of projections formed therein defining a twist-lock head receiving socket opening.
13. The rotary surface finishing implement of claim 9, wherein the one of the power tool coupling arrangements configured for removable mounting of the rotary surface finishing implement to a threaded arbor of a power tool comprises a collar with an internally threaded bore.
14. The rotary surface finishing implement of claim 13, wherein the coupling socket sidewall removably engages the collar with the internally threaded bore.
15. The rotary surface finishing implement of claim 1, wherein the power tool mounting arrangement comprises a collar with an internally threaded bore configured for threadably engaging a threaded arbor of a rotary power tool, and a power tool mounting adapter removably attached to the collar, the power tool mounting adapter comprising a socket configured for engaging with a quick-connect coupling of a rotary power tool.
16. The rotary surface finishing implement of claim 15, wherein the socket is comprised of a plate with a socket opening formed therein.

17. The rotary surface finishing implement of claim 16, wherein the socket is further comprised of a sidewall extending from the plate that engages the collar removably attaching the socket to the collar.

18. The rotary surface finishing implement of claim 1, wherein the power tool mounting arrangement comprises a first collar with a first internally threaded bore of a first diameter configured for threadably engaging a threaded arbor of a rotary power tool having a first diameter, and a second collar with a second internally threaded bore of a second diameter that is threadably removably received in the first internally threaded bore of the first collar.

19. The rotary surface finishing implement of claim 18, wherein each collar has an enlarged head at one end from which an elongate tube outwardly extends.

20. The rotary surface finishing implement of claim 19, wherein the elongate tube of one of the collars is formed of a tubular sidewall that is internally threaded and externally threaded.

21. The rotary surface finishing implement of claim 18, further comprising a removable power tool mounting adapter comprised of a socket configured for releasably engaging with a quick-connect coupling assembly of a rotary power tool.

22. The rotary surface finishing implement of claim 21, wherein the socket is comprised of a socket opening formed in a plate carried by a sidewall releasably engaging one of the collars.

23. A rotary surface finishing implement comprised of a power tool mounting arrangement adapted for mounting to rotary power tools having a plurality of different types and sizes of mounting arrangements with one of the mounting arrangements comprising a collar fixed to the implement and having an internally threaded bore configured for receiving a threaded arbor of a rotary power tool, and another one of the mounting arrangements comprising a removable adapter having a quick-connect clamp or twist-lock coupling engaging socket for receiving one of a quick-disconnect clamp or twist-lock coupling arrangement of a rotary power tool.

24. The rotary surface finishing implement of claim 23, wherein the collar is comprised of an enlarged head and a tube extending axially therefrom, and the socket is comprised of a socket sidewall engaged with the head of the collar to releasably mount the adapter thereto.

25. The rotary surface finishing implement of claim 24, wherein the socket is further comprised of a socket anchor plate carried by the socket sidewall, the socket anchor plate overlying the collar.

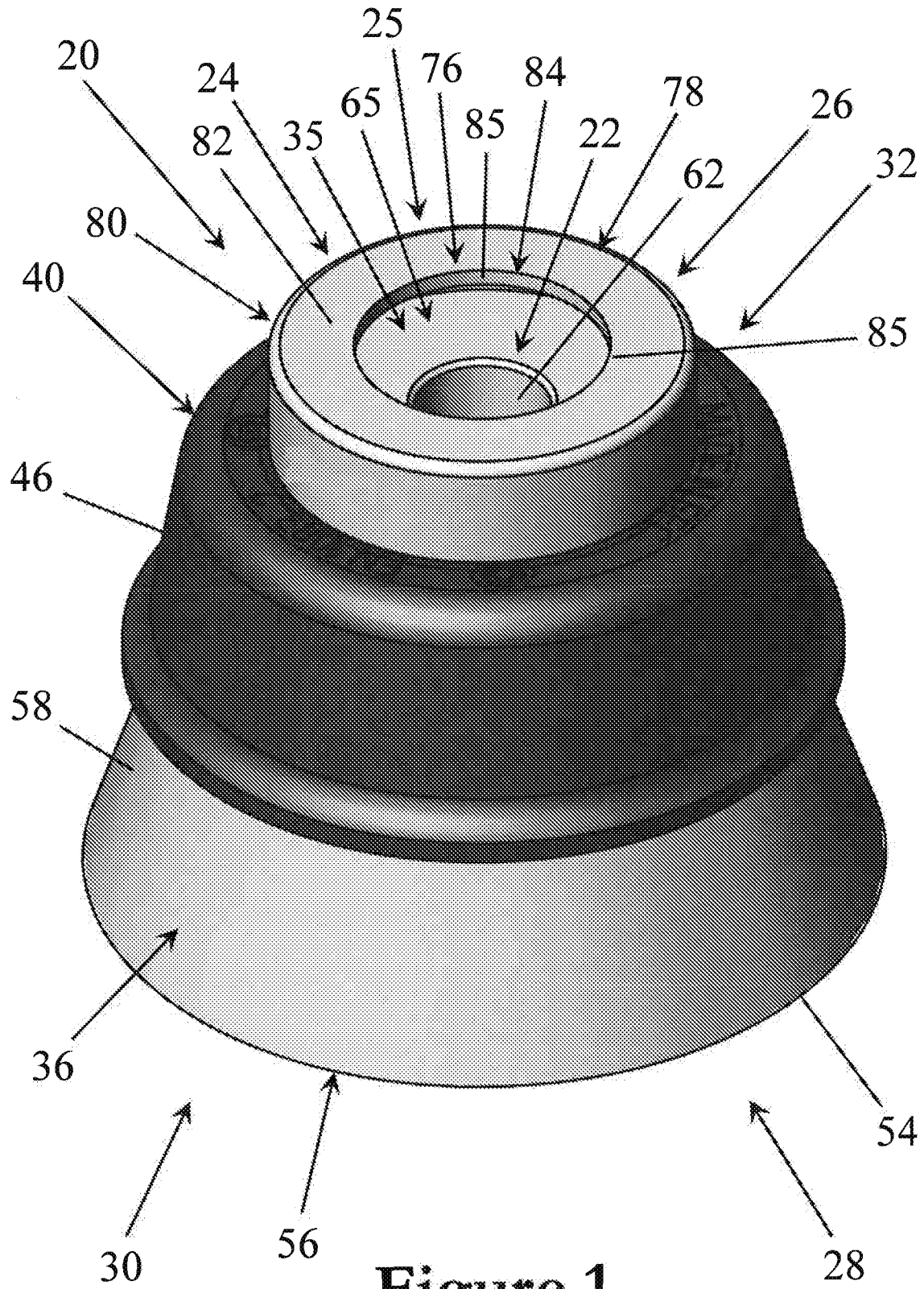

Figure 1

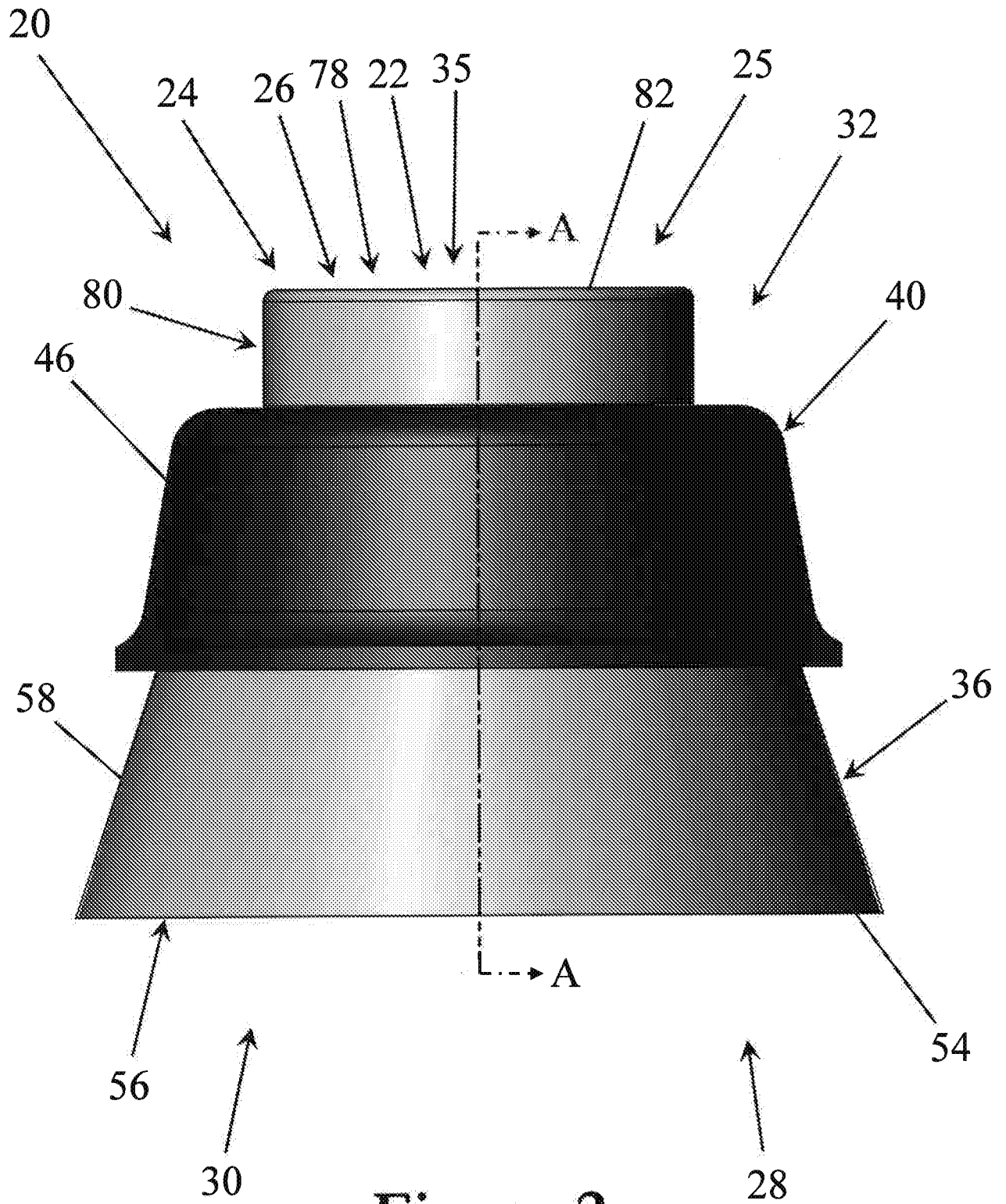

Figure 2

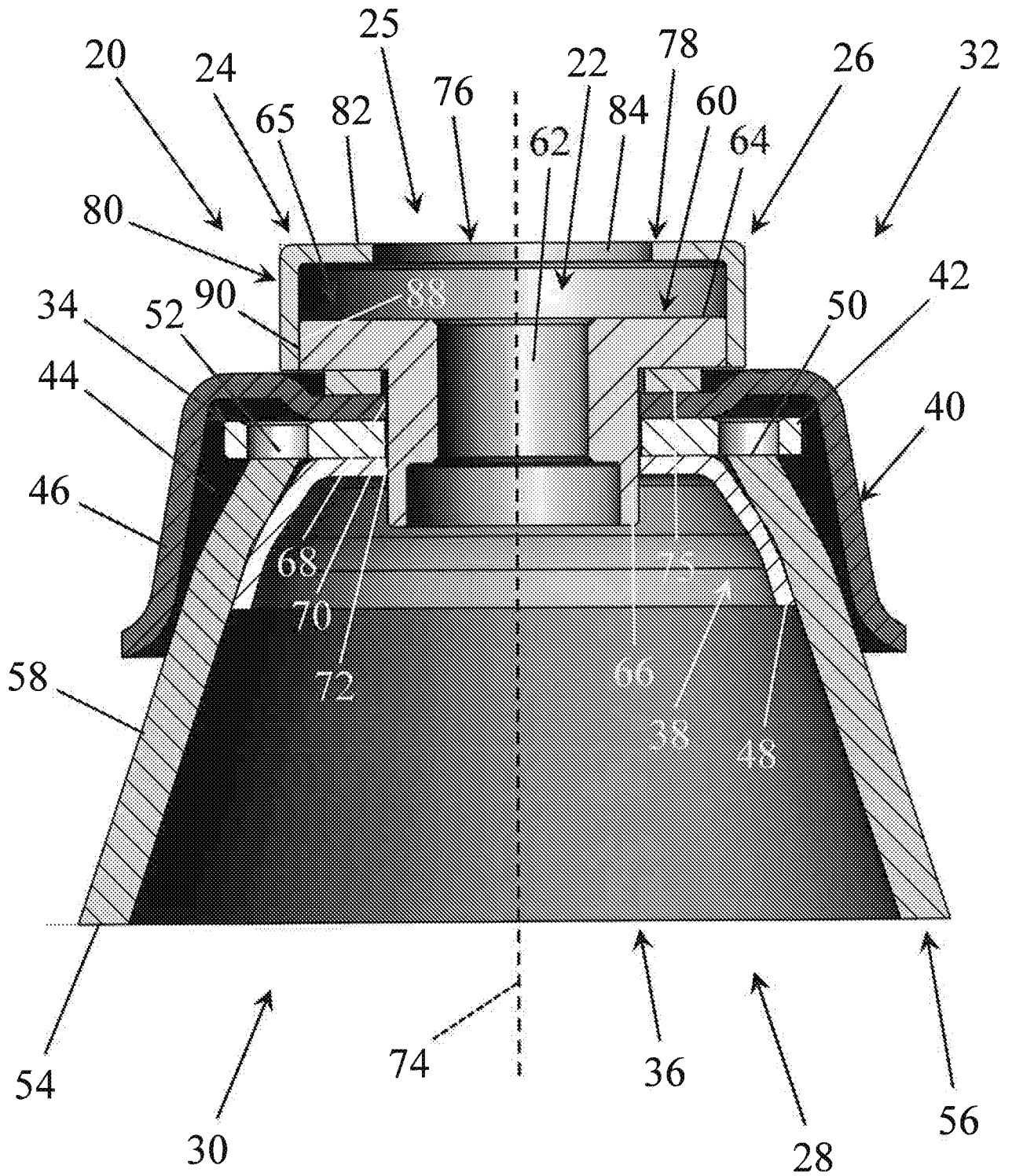

Figure 3

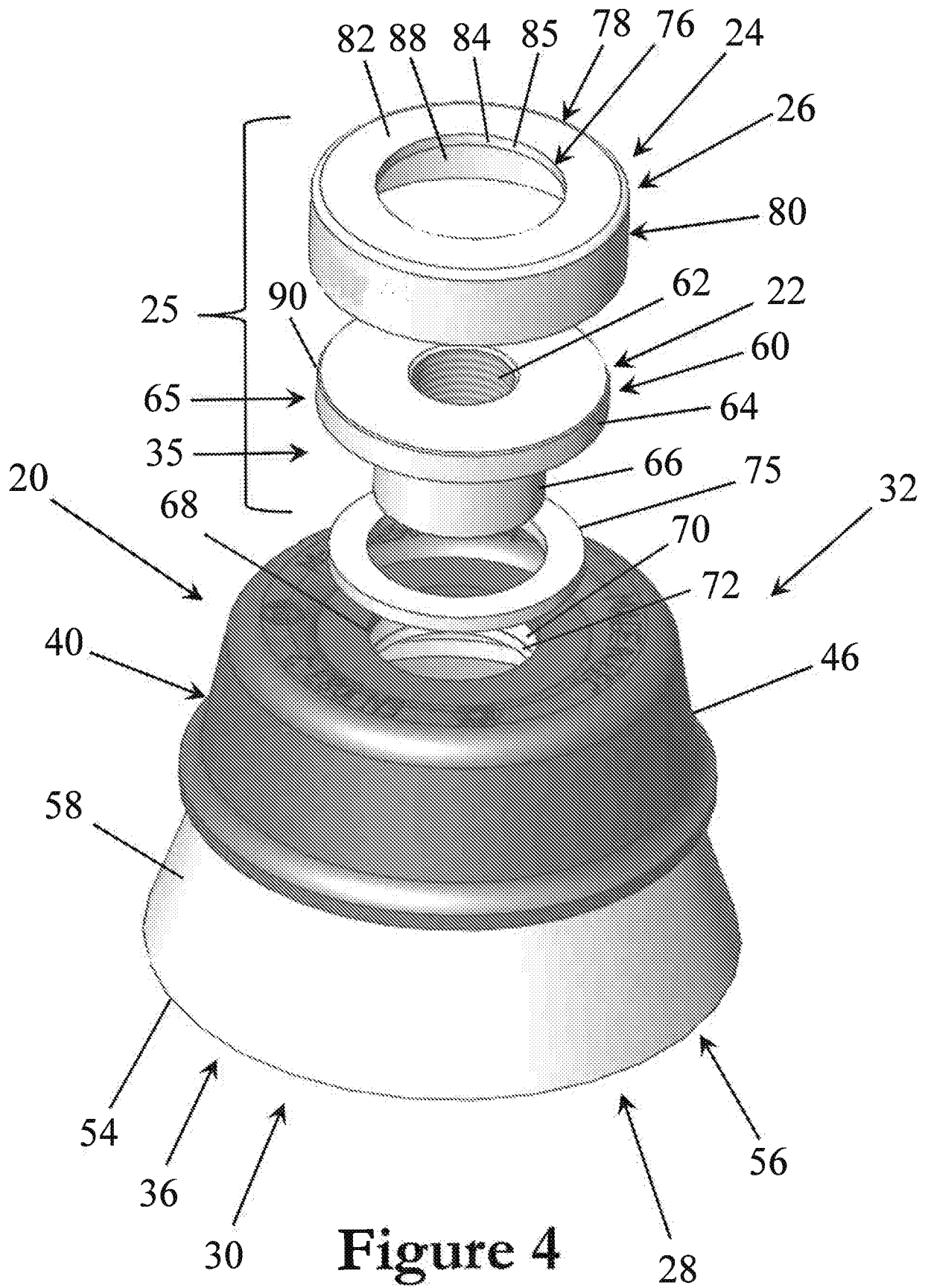

Figure 4

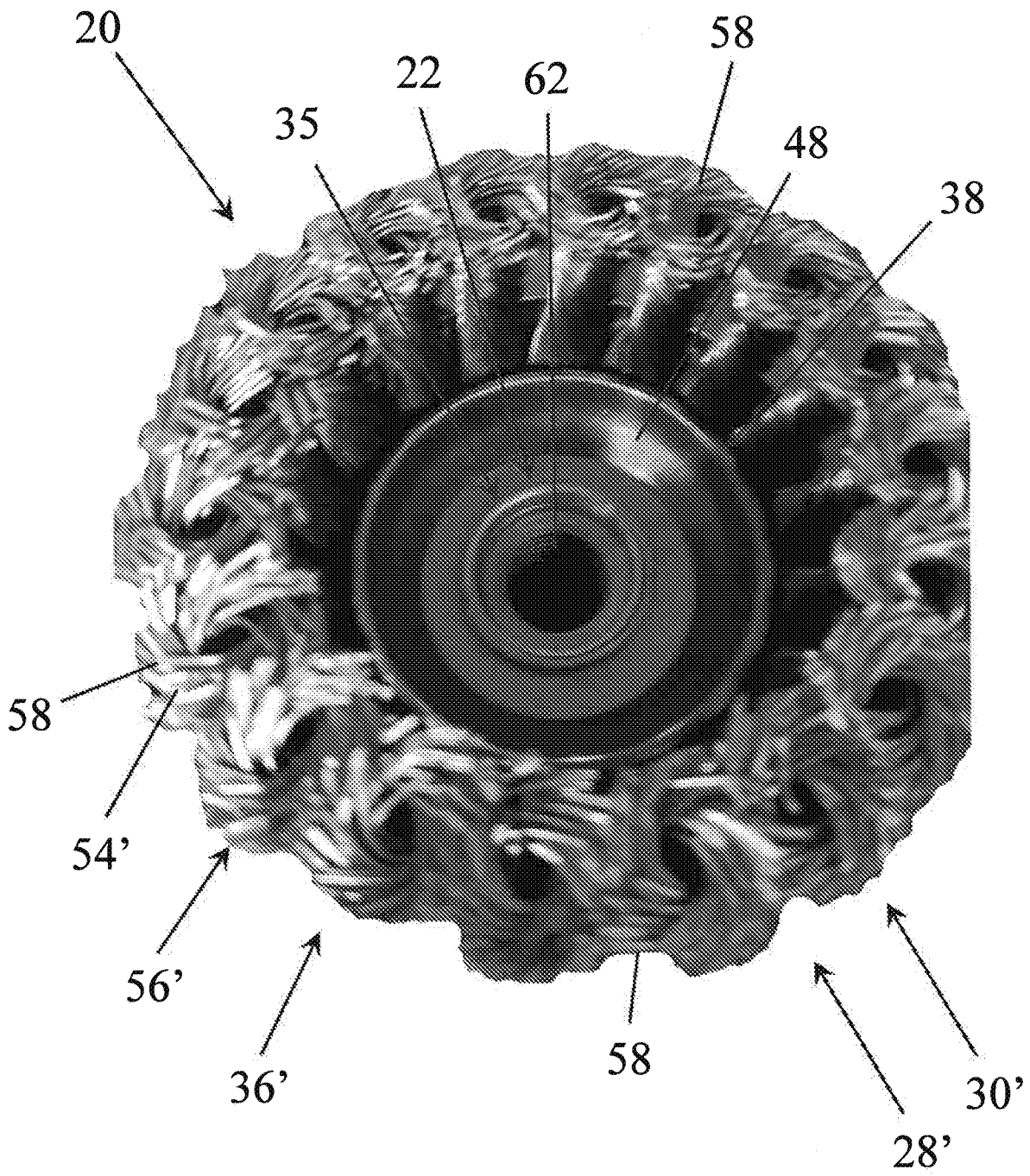

Figure 5

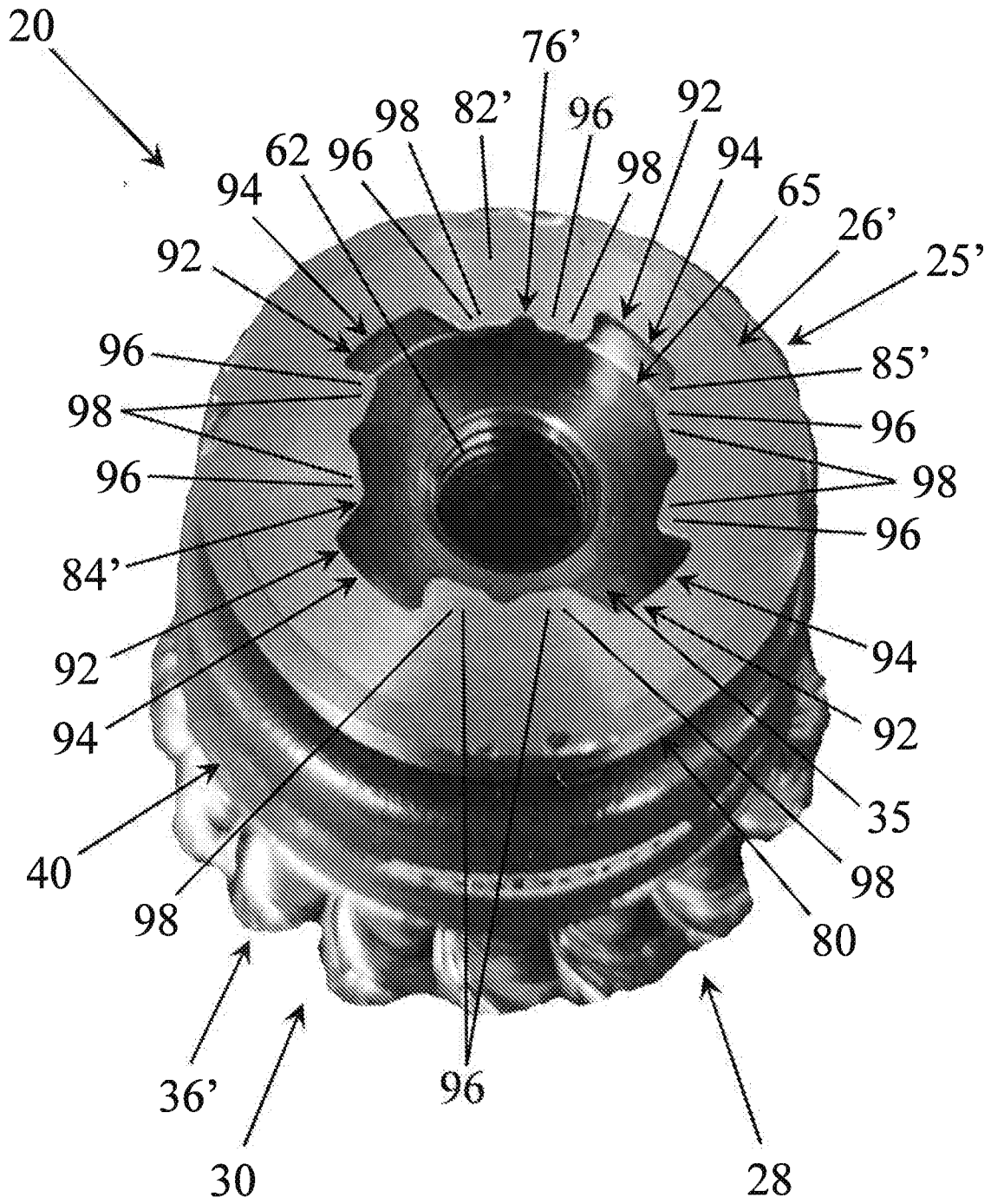

Figure 6

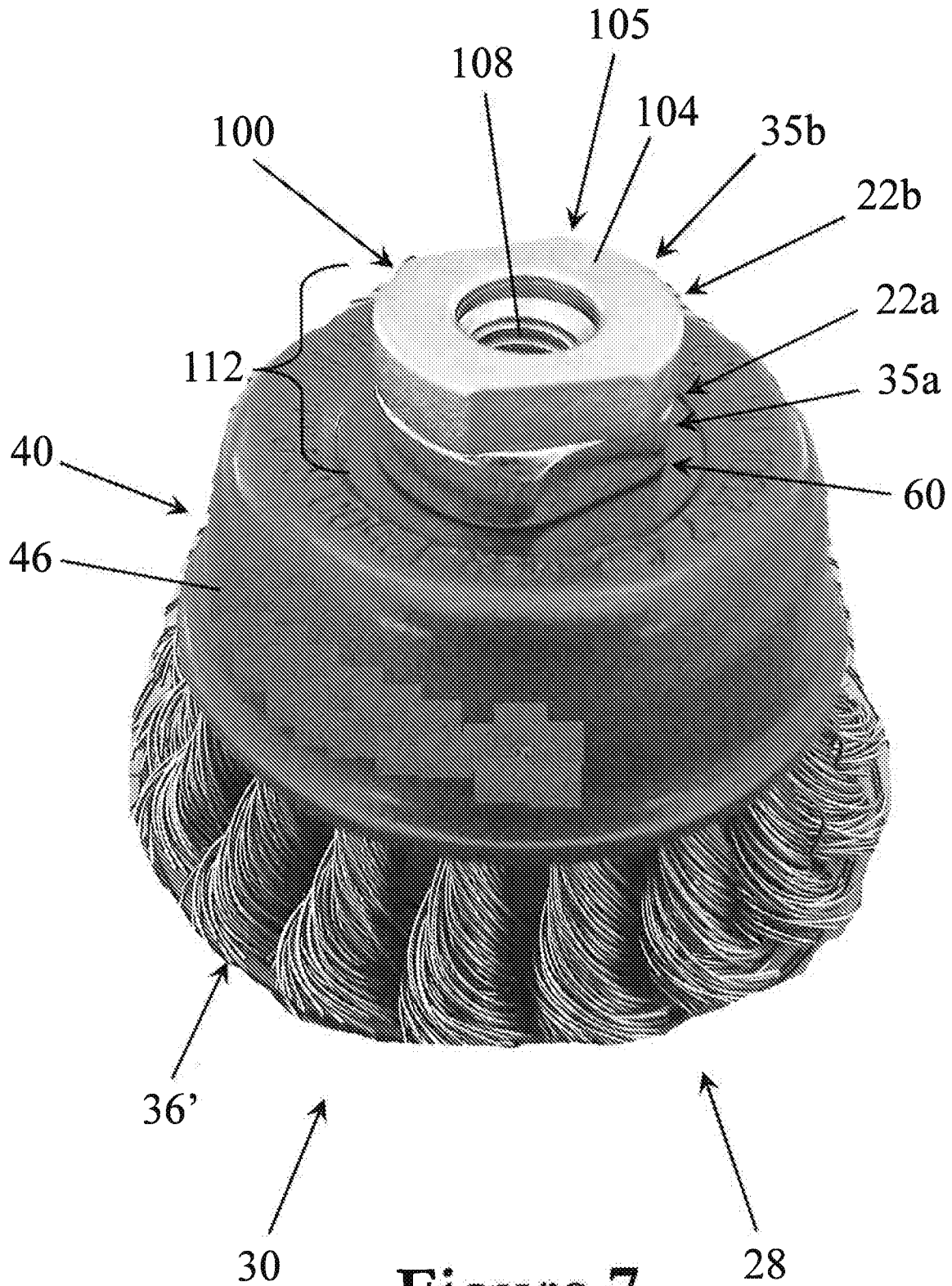

Figure 7

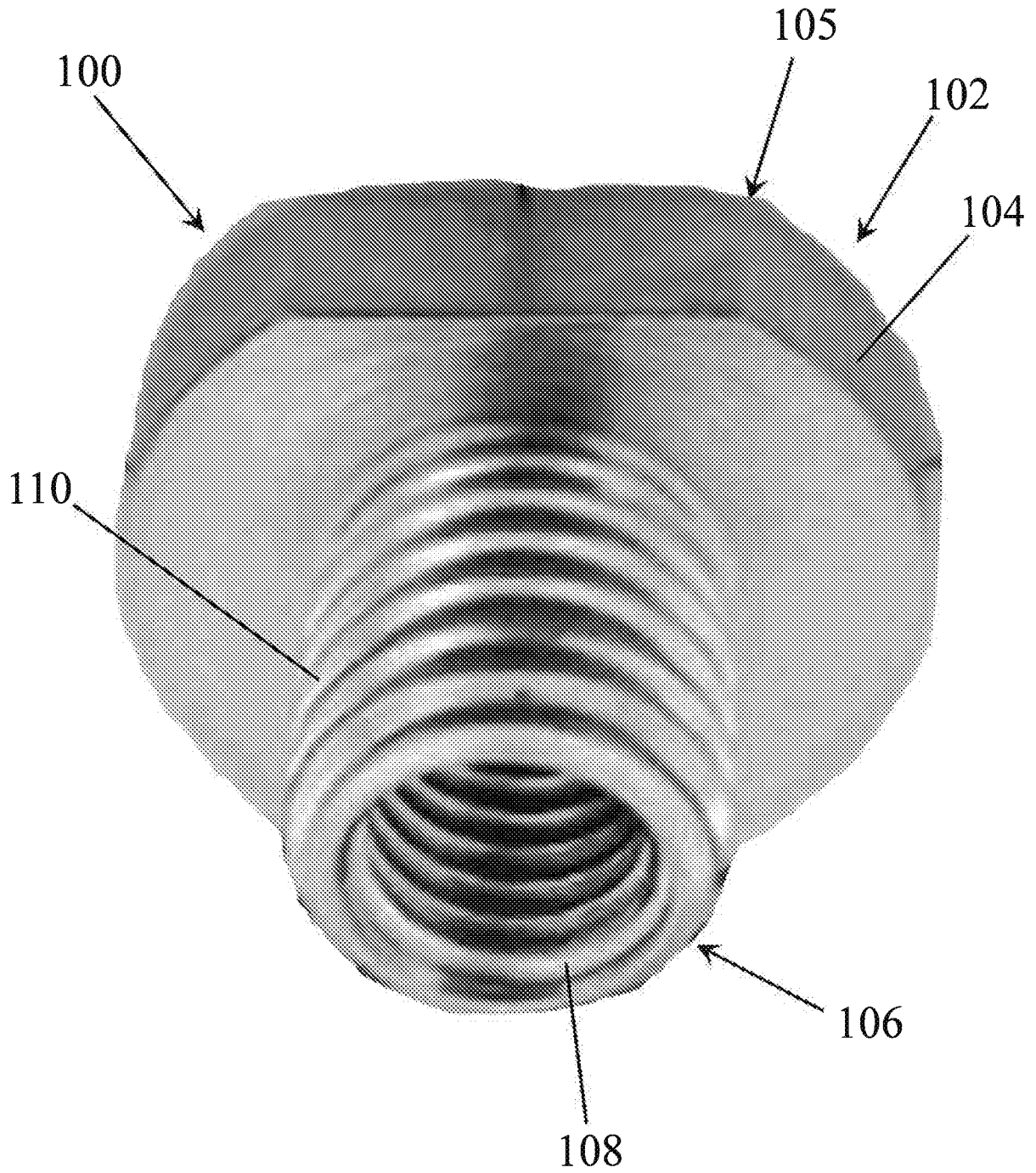

Figure 8

A. CLASSIFICATION OF SUBJECT MATTER**B24B 45/00(2006.01)i, B24B 23/00(2006.01)i**

According to International Patent Classification (IPC) or to both national classification and IPC

B. FIELDS SEARCHEDMinimum documentation searched (classification system followed by classification symbols)
B24B 45/00; A47L 11/14; A47L 11/40; B23B 51/04; B24B 23/00; B24B 23/02; B24D 7/16Documentation searched other than minimum documentation to the extent that such documents are included in the fields searched
Korean utility models and applications for utility models
Japanese utility models and applications for utility modelsElectronic data base consulted during the international search (name of data base and, where practicable, search terms used)
eKOMPASS(KIPO internal) & Keywords:rotary surface implement, power tool, socket, clamp, annular ring**C. DOCUMENTS CONSIDERED TO BE RELEVANT**

Category*	Citation of document, with indication, where appropriate, of the relevant passages	Relevant to claim No.
X	US 6523214 B1 (KAISER, RICHARD A.) 25 February 2003 See column 1, line 6 - column 7, line 63; claim 1; and figures 1-4, 6-10, 12.	1, 18-22
Y		2-17, 23-25
Y	US 6341925 B1 (DESPRES, ROGER J.) 29 January 2002 See column 11, lines 40-67; claim 1; and figure 1.	2-17, 23-25
A	KR 10-0973157 B1 (KIM, KYUNG JIN) 30 July 2010 See paragraphs [0016]-[0024]; and figures 1-2, 3a, 4, 5a, 6a.	1-25
A	KR 10-2009-0041444 A (DYNABRADE, INC.) 28 April 2009 See paragraphs [0032]-[0040]; and figures 1-7.	1-25
A	KR 10-1056036 B1 (KIM et al.) 10 August 2011 See claim 1; and figures 1, 2a, 3.	1-25

 Further documents are listed in the continuation of Box C. See patent family annex.

* Special categories of cited documents:

"A" document defining the general state of the art which is not considered to be of particular relevance

"E" earlier application or patent but published on or after the international filing date

"L" document which may throw doubts on priority claim(s) or which is cited to establish the publication date of another citation or other special reason (as specified)

"O" document referring to an oral disclosure, use, exhibition or other means

"P" document published prior to the international filing date but later than the priority date claimed

"T" later document published after the international filing date or priority date and not in conflict with the application but cited to understand the principle or theory underlying the invention

"X" document of particular relevance; the claimed invention cannot be considered novel or cannot be considered to involve an inventive step when the document is taken alone

"Y" document of particular relevance; the claimed invention cannot be considered to involve an inventive step when the document is combined with one or more other such documents, such combination being obvious to a person skilled in the art

"&" document member of the same patent family

Date of the actual completion of the international search

19 June 2019 (19.06.2019)

Date of mailing of the international search report

19 June 2019 (19.06.2019)

Name and mailing address of the ISA/KR

International Application Division
Korean Intellectual Property Office
189 Cheongsa-ro, Seo-gu, Daejeon, 35208, Republic of Korea

Facsimile No. +82-42-481-8578

Authorized officer

LEE, Dal Kyong

Telephone No. +82-42-481-8440



INTERNATIONAL SEARCH REPORT

Information on patent family members

International application No.

PCT/US2019/020627

Patent document cited in search report	Publication date	Patent family member(s)	Publication date
US 6523214 B1	25/02/2003	AU 2001-61718 A1 WO 2001-096067 A1	24/12/2001 20/12/2001
US 6341925 B1	29/01/2002	AU 2001-50801 A1 US 2002-0037201 A1 US 2002-0131835 A1 US 6409436 B1 US 6641338 B2 WO 2001-064379 A1	12/09/2001 28/03/2002 19/09/2002 25/06/2002 04/11/2003 07/09/2001
KR 10-0973157 B1	30/07/2010	KR 10-2010-0008489 A	26/01/2010
KR 10-2009-0041444 A	28/04/2009	CN 101511535 A EP 2061628 A2 TW 200821090 A US 2008-0057842 A1 US 2009-0209182 A1 US 2010-0151775 A1 US 7713110 B2 WO 2008-030401 A2 WO 2008-030401 A3 WO 2011-106636 A1	19/08/2009 27/05/2009 16/05/2008 06/03/2008 20/08/2009 17/06/2010 11/05/2010 13/03/2008 14/08/2008 01/09/2011
KR 10-1056036 B1	10/08/2011	None	