

Dec. 7, 1926.

1,609,351

T. P. EUSTEGE
LEVER LID CONTAINER
Filed July 17, 1924

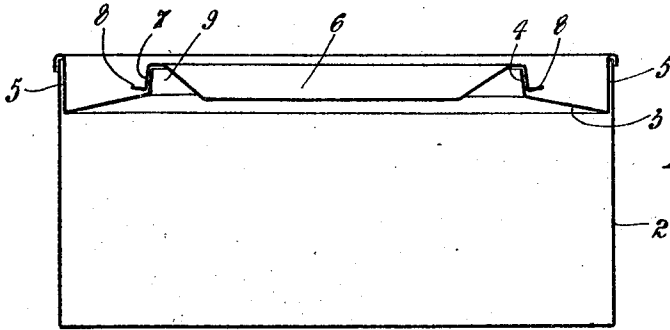

Fig. 1.

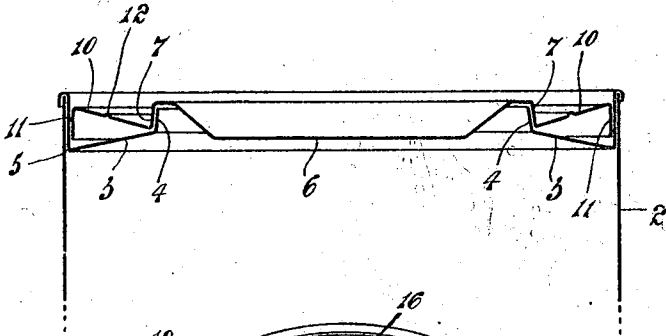

Fig. 2.

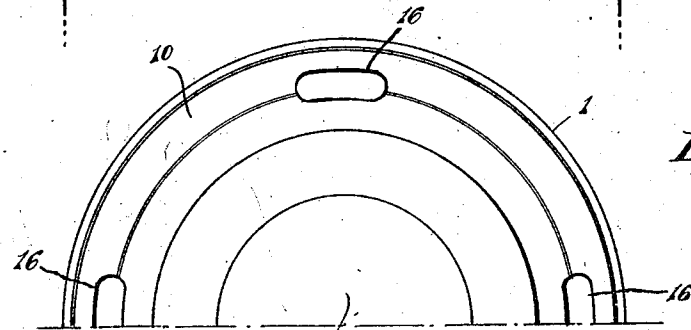

Fig. 3.

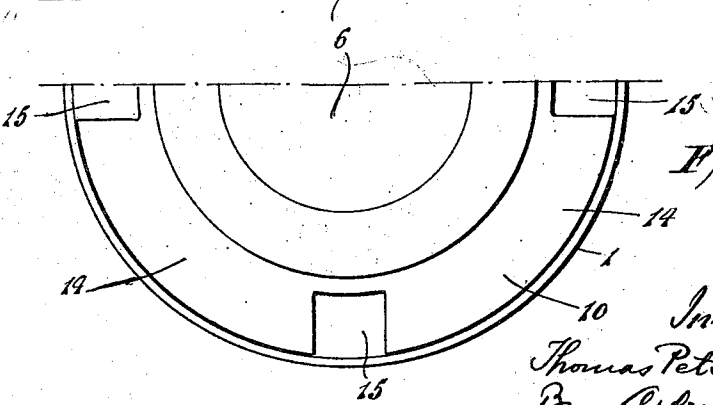

Fig. 4.

Inventor:
Thomas Peter Eustege
By Alfred H. ...
Att.

UNITED STATES PATENT OFFICE.

THOMAS PETER EUSTEGE, OF WELLINGTON, NEW ZEALAND.

LEVER LID CONTAINER.

Application filed July 17, 1924, Serial No. 726,418, and in New Zealand September 4, 1923.

My invention relates to containers using lever lids in which the lid fits upon the exterior of a neck forming the top of the container.

5 The object of the present invention is to provide a container which will not have any recesses in which the contents may lodge and can, therefore, be easily cleaned, and also to enable the contents to be easily poured out
10 thereof.

Accordingly the top or neck of the container is formed with a portion sloping downwardly towards the wall of the container within the interior thereof, while an
15 extension of such portion slopes upwards and slightly inwards towards the top. The lid is formed with a downwardly turned portion to fit over the extension, such downwardly turned portion and the extension
20 being such that the lid will tend to jamb on the extension. An outwardly turned flange is provided at the bottom of the downwardly turned portion of the lid in order to enable such lid to be easily levered off, and for
25 this purpose the flange is preferably turned slightly upwards.

The sloping portion referred to forming the neck is preferably formed with an upturned vertical wall extending to a height
30 corresponding with or slightly above the top portion of the lid, the top portion of such wall being turned downwardly for the purpose of being swedged upon the top edge of the container. The lid is preferably formed
35 with a central depression so as to leave an annular recess near the downwardly turned portion of the lid. This recess enables the lid to be more easily placed in position.

In some cases the lid is extended over the
40 neck and formed with a depending circumferential flange adapted to wedge upon the inner side of the vertical wall of the neck. This construction does not provide any ridge or shoulder whereby the lid may be levered
45 off, and thus provides a sealed container. To remove the lid the metal between the two wedging portions is severed, by an ordinary can opener, and the centre portion will then become the lid, and this lid may be levered
50 off and used in the usual way. To indicate and facilitate the cutting, the lid may be marked or partially cut during the manufacture thereof, along the preferred line of severing such lid. The outer flange may, if
55 desired, be soldered to the vertical wall to give greater security in the sealing.

The invention will be described with reference to the accompanying drawings, wherein:—

Figure 1 is a cross section through the
60 upper part of a container.

Figure 2 is a similar view showing a double joint.

Figure 3 is a plan of the device shown in
65 Figure 2.

Figure 4 is a plan of a modification.

According to the drawings, a ring 1 adapted to enter the container 2 is formed with a portion 3 sloping downwardly towards
70 the wall of the container. An extension of the sloping portion forms a neck 4 sloping slightly inwards towards the top while the exterior of the ring is formed with an upturned vertical wall 5 extending to a height
75 corresponding with or slightly above the top portion of the lid 6. The top edge of such wall is turned downwardly for the purpose of attachment to the top edge of the container, as shown. The lid 6 is formed with
80 a downwardly turned portion 7 to fit over the neck 4, such downwardly turned portion 7 and the neck 4 being such that the lid 6 will tend to jamb on the neck. In Figure 1 an outwardly turned flange 8 is provided
85 at the bottom of the downwardly turned portion 7 of the lid in order to enable such lid to be easily levered off, and for this purpose such flange is preferably turned slightly upwards. The lid is preferably formed
90 with a central depression so as to leave an annular tapered recess 9 near the downwardly turned portion of the lid. This recess enables the lid to be more easily placed in position and gives greater strength to the
95 lid.

In Figures 2, 3 and 4, the lid 6 is extended beyond the neck 4 by a portion 10 and such
100 portion is formed with a depending circumferential flange 11 adapted to wedge upon the inner side of the vertical wall 5. This construction does not provide any ridge or shoulder whereby the lid may be levered off and thus results in a sealed container.

To remove the lid, the metal between the two wedging portions may be severed by an
105 ordinary can opener by cutting the portion 10 between the flange 4 and the flange 11 thus leaving the central portion forming the lid 6 which will then correspond to that described in Figure 1. This lid may be
110 levered off and used in the usual way. To facilitate the cutting the portion 10 may be

marked with a bead 12 or may be partially cut during the manufacture thereof along the preferred line of severing. The outer flange 11 may, if desired, be soldered to the vertical wall to give greater security in the sealing.

Instead of the sections 14 shown in Fig. 4, the sloping portion 10 has cut in the metal thereof a number of openings 16 (indicated by dotted lines in Fig. 3). These openings are situated midway between the two wedging portions 7 and 11 so that an instrument may be inserted through the openings 16 for the purpose of raising the wedging portions 7 and 11.

What I claim is:—

1. In a lever lid container having a lid fitting upon the exterior of a neck, a ring having a vertical wall fitting within the wall of the container at the top thereof, a portion of said ring extending in an up-

wardly sloping direction towards the centre of the container, an upward extension of said sloping portion sloping slightly inwards and forming a neck to receive the lid, an extension of said lid towards the vertical wall of said ring, and a depending circumferential flange upon said extension adapted to wedge upon the inner side of said vertical wall.

2. In a lever lid container as claimed in claim 1, a number of openings in said extension whereby an instrument may be inserted to raise the lid, substantially as described.

3. In a lever lid container as claimed in claim 1, a circumferential bead in the said extension to indicate the desired line of cutting, substantially as described.

In testimony whereof, I have signed my name to this specification.

THOMAS PETER EUSTEGGE.