



- (51) International Patent Classification:  
*F01N 3/08* (2006.01)     *B01D 53/24* (2006.01)
- (21) International Application Number:  
PCT/US2011/063848
- (22) International Filing Date:  
7 December 2011 (07.12.2011)
- (25) Filing Language: English
- (26) Publication Language: English
- (30) Priority Data:  
61/420,751     7 December 2010 (07.12.2010)     US  
13/314,110     7 December 2011 (07.12.2011)     US
- (72) Inventors; and
- (71) Applicants : LANG, Jerry [US/US]; 612 Hideaway Lane East, Lindale, TX 75771 (US). SCOTT, David [US/US]; 1465 Hickory Creek Lane, Rockwall, TX 75032 (US).

- (74) Agent: CHALKER, Daniel J.; Chalker Flores LLP, 14951 North Dallas Parkway, Suite 400, Dallas, TX 75254 (US).
- (81) Designated States (unless otherwise indicated, for every kind of national protection available): AE, AG, AL, AM, AO, AT, AU, AZ, BA, BB, BG, BH, BR, BW, BY, BZ, CA, CH, CL, CN, CO, CR, CU, CZ, DE, DK, DM, DO, DZ, EC, EE, EG, ES, FI, GB, GD, GE, GH, GM, GT, HN, HR, HU, ID, IL, IN, IS, JP, KE, KG, KM, KN, KP, KR, KZ, LA, LC, LK, LR, LS, LT, LU, LY, MA, MD, ME, MG, MK, MN, MW, MX, MY, MZ, NA, NG, NI, NO, NZ, OM, PE, PG, PH, PL, PT, QA, RO, RS, RU, RW, SC, SD, SE, SG, SK, SL, SM, ST, SV, SY, TH, TJ, TM, TN, TR, TT, TZ, UA, UG, US, UZ, VC, VN, ZA, ZM, ZW.
- (84) Designated States (unless otherwise indicated, for every kind of regional protection available): ARIPO (BW, GH, GM, KE, LR, LS, MW, MZ, NA, RW, SD, SL, SZ, TZ, UG, ZM, ZW), Eurasian (AM, AZ, BY, KG, KZ, MD, RU, TJ, TM), European (AL, AT, BE, BG, CH, CY, CZ, DE, DK, EE, ES, FI, FR, GB, GR, HR, HU, IE, IS, IT, LT, LU,

[Continued on next page]

(54) Title: SYSTEM AND METHOD FOR SEPARATING HIGH MOLECULAR WEIGHT GASES FROM A COMBUSTION SOURCE

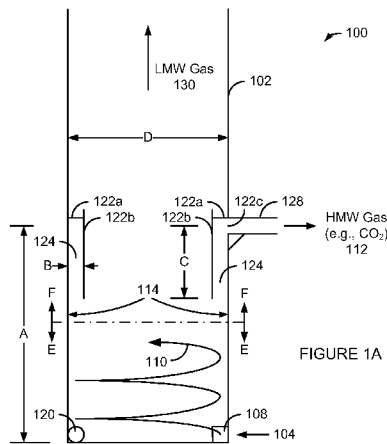
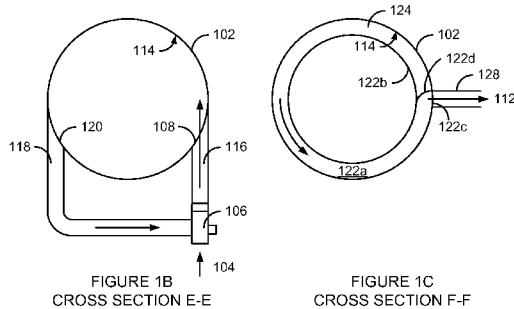

FIGURE 1A



(57) Abstract: High molecular weight (HMW) gases are separated from an exhaust gas of a combustion source using a blower and an interior vent within the exhaust stack. The interior vent includes a vent wall having a top portion attached to the interior surface of the exhaust stack along the entire inner perimeter of the exhaust stack and a lower portion that extends downward into the exhaust stack to form an annular space or gap between the vent wall and the interior surface of the exhaust stack, and at least one opening in the interior surface of the exhaust stack between the top and bottom portions of the vent wall. The blower creates a tangential flow of the exhaust gas with sufficient centrifugal force to concentrate substantially all of the HMW gases along the inner surface of the exhaust stack. A transfer pipe removes the HMW gases from the interior vent.

WO 2012/078821 A2

LV, MC, MK, MT, NL, NO, PL, PT, RO, RS, SE, SI, SK, **Published:**  
SM, TR), OAPI (BF, BJ, CF, CG, CI, CM, GA, GN, GQ, — *without international search report and to be republished*  
GW, ML, MR, NE, SN, TD, TG). *upon receipt of that report (Rule 48.2(g))*

## SYSTEM AND METHOD FOR SEPARATING HIGH MOLECULAR WEIGHT GASES FROM A COMBUSTION SOURCE

### 5 **Field of Invention**

The present invention relates generally to the field of separation and sequestration of combustion exhaust gases.

### **Background Art**

Combustion systems have come under increased scrutiny for toxic emissions which  
10 are a by-product of the combustion process. Depending upon the extent of the combustion, carbon monoxide and NO<sub>x</sub> may be emitted at unacceptable levels. Carbon monoxide levels are normally controlled through complete combustion resulting in carbon dioxide. In fact, in years past, carbon dioxide was measured to determine the efficiency of the process. Traditionally, NO<sub>x</sub> and other VOC emissions have been either controlled by  
15 cleaner fuels or techniques that reduce formation. Recently, because of the push for alternative and renewable fuels, carbon dioxide being the only component here-to-fore not regulated has come under increased scrutiny (green house gases, carbon footprints and global warming). The problem is, burning fossil fuels makes carbon dioxide, and burning fossil fuels more efficiently makes even more carbon dioxide. NO<sub>x</sub> and SO<sub>x</sub> along with  
20 other pollutants, which comprise only parts per million in the resulting emissions, are controlled by many effective methods; but there few effective methods of controlling CO<sub>2</sub> emissions.

Since CO<sub>2</sub> comprises from 10 to 15% of the exhaust or flue gas by volume, it is impractical to treat it without separating it from the remaining gases. Several systems have  
25 been developed to reduce the CO<sub>2</sub>, and in some cases to concentrate the gas. Increasing the amount of hydrogen in the fuel will reduce the fraction of CO<sub>2</sub> in the flue gas, since hydrogen combustion does not produce CO<sub>2</sub>. If the exhaust or flue gas is recirculated and the incoming fuel is mixed with pure O<sub>2</sub> the nitrogen in the air is eliminated. And, with enough recycling of the exhaust or flue gas, the CO<sub>2</sub> is concentrated to higher levels.  
30 After concentration, there are accepted methods of either using or treating the CO<sub>2</sub>. The burning of the hydrogen simply reduces the CO<sub>2</sub>. These known methods are quite inflexible and require reconfiguring the combustion equipment. In many cases, very

flexible control algorithms will need to be employed to adjust the various fuel-air curves needed for the ever changing fuel compositions. The production or purchase of the hydrogen or oxygen needed in these processes also tend to make them impractical.

## 5 **Summary of the Invention**

The present invention provides a system and method for separating high molecular weight gases, such as CO<sub>2</sub>, from any combustion source. More specifically, the present invention imparts centrifugal force on the exhaust or flue gas by spinning the exhaust or flue gas with enough velocity to remove the heavy components, such as CO<sub>2</sub>, to the outside diameter of the stack and removing it thru an annular space or gap formed by an interior vent. The spin needed for the centrifugal action may be imparted by using a blower to remove the gas tangentially from one side of the stack and blowing it tangentially back into the stack on the other side. The use of a stationary tubulator, or spin vanes, or actual in-stack centrifuge may be necessary in addition to the blower. Note that the velocity of the system may be varied to accommodate various fuels and flue gas mixtures. Moreover, the system may be fitted to stacks of virtually any size or flow. As a result, the present invention provides a simple process to take care of the hardest and most expensive step in controlling CO<sub>2</sub>. Many treatment options are available after separation.

One embodiment of the present invention provides a method for separating high molecular weight gases from an exhaust gas of a combustion source by providing (a) a blower attached to an intake of an exhaust stack to receive the exhaust gas from the combustion source, (b) an interior vent within the exhaust stack comprising (i) a vent wall having a top portion attached to the interior surface of the exhaust stack along the entire inner perimeter of the exhaust stack and a lower portion that extends downward into the exhaust stack to form an annular space or gap between the vent wall and the interior surface of the exhaust stack, and (ii) at least one opening in the interior surface of the exhaust stack between the top and bottom portions of the vent wall, and (c) a transfer pipe connected to the at least one opening in the interior surface of the exhaust stack. A tangential flow of the exhaust gas is created within the exhaust stack using the blower, wherein the blower imparts sufficient centrifugal force on the exhaust gas to concentrate substantially all of the high molecular weight gases along the inner surface of the exhaust stack. The high molecular weight gases concentrated along the inner surface of the exhaust

stack are collected using the interior vent. The high molecular weight gases are removed from the interior vent using the transfer pipe.

In addition, the present invention provides a system for separating high molecular weight gases in an exhaust stack from an exhaust gas of a combustion source using a blower, an interior vent and a transfer pipe. The blower is attached to an intake of the exhaust stack to receive the exhaust gas from the combustion source and create a tangential flow of the exhaust gas within the exhaust stack. The blower imparts sufficient centrifugal force on the exhaust gas to concentrate the high molecular weight gases along the inner surface of the exhaust stack. The interior vent is disposed within the exhaust stack and collects the high molecular weight gases concentrated along the inner surface of the exhaust stack. The interior vent includes (i) a vent wall having a top portion attached to the interior surface of the exhaust stack along the entire inner perimeter of the exhaust stack and a lower portion that extends downward into the exhaust stack to form an annular space or gap between the vent wall and the interior surface of the exhaust stack, and (ii) at least one opening in the interior surface of the exhaust stack between the top and bottom portions of the vent wall. The transfer pipe is connected to the at least one opening in the interior surface of the exhaust stack to remove the high molecular weight gases from the interior vent.

Moreover, the present invention provides a system for separating high molecular weight gases from an exhaust gas of a combustion source using an exhaust stack, a blower, an interior vent and a transfer pipe. The blower is attached to an intake of the exhaust stack to receive the exhaust gas from the combustion source and create a tangential flow of the exhaust gas within the exhaust stack. The blower imparts sufficient centrifugal force on the exhaust gas to concentrate the high molecular weight gases along the inner surface of the exhaust stack. The interior vent is disposed within the exhaust stack and collects the high molecular weight gases concentrated along the inner surface of the exhaust stack. The interior vent includes (i) a vent wall having a top portion attached to the interior surface of the exhaust stack along the entire inner perimeter of the exhaust stack and a lower portion that extends downward into the exhaust stack to form an annular space or gap between the vent wall and the interior surface of the exhaust stack, and (ii) at least one opening in the interior surface of the exhaust stack between the top and bottom portions of the vent wall. The transfer pipe is connected to the at least one opening in the interior surface of the exhaust stack to remove the high molecular weight gases from the interior vent. The high

molecular weight gases have a molecular weight greater than 35 and at least 85% of the high molecular weight gases are concentrated along the inner surface of the exhaust stack. The annular space or gap has an area of approximately 10% of a cross-sectional area of the exhaust stack. The at least one opening is positioned at a height above the bottom of the exhaust stack approximately equal to three diameters of the exhaust stack. The blower causes the exhaust gases to spin around the exhaust stack at least five times within a height approximately equal to one diameter of the exhaust stack.

The present invention is described in detail below with reference to the accompanying drawings which are not to scale.

## 10 **Brief Description of the Drawings**

Further benefits and advantages of the present invention will become more apparent from the following description of various embodiments that are given by way of example with reference to the accompanying drawings:

FIGURES 1A, 1B and 1C are a cross sectional side view (FIGURE 1A), a cross-sectional top view at cross section E-E (FIGURE 1B), and a cross-sectional bottom view at cross section F-F (FIGURE 1C) of a system for separating high molecular weight (HMW) gases in an exhaust stack in accordance with one embodiment of the present invention;

FIGURES 2A, 2B and 2C are a cross sectional side view (FIGURE 2A), a cross-sectional top view at cross section E-E (FIGURE 2B), and a cross-sectional bottom view at cross section F-F (FIGURE 2C) of a system for separating high molecular weight (HMW) gases in an exhaust stack in accordance with another embodiment of the present invention;

FIGURES 3A, 3B and 3C are a cross sectional side view (FIGURE 3A), a cross-sectional top view at cross section E-E (FIGURE 3B), and a cross-sectional bottom view at cross section F-F (FIGURE 3C) of a system for separating high molecular weight (HMW) gases in an exhaust stack in accordance with one embodiment of the present invention;

FIGURE 4 is a flow chart of a method for separating high molecular weight (HMW) gases from an exhaust gas in accordance with one embodiment of the present invention; and

FIGURE 5 is a block diagram of a system incorporating the embodiments of the present invention.

## Description of the Invention

While the making and using of various embodiments of the present invention are discussed in detail below, it should be appreciated that the present invention provides many applicable inventive concepts that can be embodied in a wide variety of specific contexts.

5 The specific embodiments discussed herein are merely illustrative of specific ways to make and use the invention and do not delimit the scope of the invention.

The present invention provides a system and method for separating high molecular weight gases, such as CO<sub>2</sub>, from any combustion source. More specifically, the present invention imparts centrifugal force on the exhaust or flue gas by spinning the exhaust or  
10 flue gas with enough velocity to remove the heavy components, such as CO<sub>2</sub>, to the outside diameter of the stack and removing it thru an annular space or gap formed by an interior vent. The spin needed for the centrifugal action may be imparted by using a blower to remove the gas tangentially from one side of the stack and blowing it tangentially back into the stack on the other side. The use of a stationary tubulator, or spin vanes, or actual in-  
15 stack centrifuge may be necessary in addition to the blower. Note that the velocity of the system may be varied to accommodate various fuels and flue gas mixtures. Moreover, the system may be fitted to stacks of virtually any size or flow. As a result, the present invention provides a simple process to take care of the hardest and most expensive step in controlling CO<sub>2</sub>. Many treatment options are available after separation.

20 The typical constituent parts of exhaust or flue gas (used interchangeably) are as follows: the molecular weight of CO<sub>2</sub> is 44 and it comprises 10 - 15% of flue gases, the molecular weight of N<sub>2</sub> is 28 and it comprises approximately 78% of flue gases, the molecular weight of O<sub>2</sub> is 32 and it comprises approximately 3% of flue gases, the molecular weight of H<sub>2</sub>O is 18 and it comprises approximately 10 - 15% of flue gases, and  
25 the molecular weight of CO is 28 and it is normally a negligible percentage of the flue gas. These numbers indicate the CO<sub>2</sub> will need to be basically separated from the N<sub>2</sub> with a differential molecular weight of 16. After the CO<sub>2</sub> is separated from the flue gases, it can be compressed, injected into the ground, or used for other processes. In one embodiment of the present invention, the CO<sub>2</sub> is collected in a tank and then flowed up thru bubble trays  
30 containing sodium hydroxide which will cause the CO<sub>2</sub> to combine and produce sodium carbonate which can be collected for use otherwise. This embodiment is particularly useful in refineries and chemical plants where sodium hydroxide is commonly used in their processes (sometimes called "caustic soda"). After the sodium hydroxide is used, the

plants use acid to reduce the used sodium hydroxide to a neutral PH so it can be disposed of. Using this byproduct does not require the purchase of gases and eliminates a disposal problem.

Now referring to FIGURES 1A, 1B and 1C, a cross sectional side view (FIGURE 1A), a cross-sectional top view at cross section E-E (FIGURE 1B), and a cross-sectional bottom view at cross section F-F (FIGURE 1C) of a system 100 for separating high molecular weight (HMW) gases 112 in an exhaust stack 102 from an exhaust gas 104 of a combustion source in accordance with one embodiment of the present invention are shown. A blower 106 is attached to an intake 108 of the exhaust stack 102 to receive the exhaust gas 104 from the combustion source (502, FIGURE 5) and create a tangential flow 110 of the exhaust gas 104 within the exhaust stack 102. The blower 106 imparts sufficient centrifugal force on the exhaust gas 104 to concentrate the high molecular weight gases 112, such as CO<sub>2</sub> or other gases having a higher molecular weight than N<sub>2</sub> or O<sub>2</sub> (e.g., greater than 35), along the inner perimeter or surface 114 of the exhaust stack 102. As used herein, "along the inner perimeter or surface of the exhaust stack" means an area within the exhaust stack 102 that is much closer to the inner surface 114 of the exhaust stack 102 than to the center of the exhaust stack 102. In other words, the high molecular weight gases 112 are concentrated near, towards or proximate to the inner surface 114 of the exhaust stack 102. The low molecular weight gases 130 exit through the top of the exhaust stack 102.

Typically, the blower 106 causes the exhaust gases 104 to spin around the interior of the exhaust stack 102 at least five times within a height approximately equal to one diameter (D) of the exhaust stack 102. As shown, the blower 106 is external to the exhaust stack 102 and is connected to the intake 108 of the exhaust stack 102 with a first pipe 116. A second pipe 118 connects the blower 106 to the bottom of the exhaust stack 102 at a point 120 approximately opposite to the intake 108 and in line with the tangential flow 110 in order to create the sufficient centrifugal force on the exhaust gas 104. The use of a stationary tubulator, or spin vanes, or actual in-stack centrifuge may be necessary in addition to the blower 106.

An interior vent 122 within the exhaust stack 102 collects the high molecular weight gases 112 concentrated along the inner surface 114 of the exhaust stack 102. The interior vent 122 includes: (i) a vent wall having a top portion 122a attached to the interior surface 114 of the exhaust stack 102 along the entire inner perimeter of the exhaust stack



102 (e.g., the top portion 122a is attached to the inner surface 114 along any side cross section of the exhaust stack 102) and a lower portion 122b that extends downward into the exhaust stack 102 to form an annular space or gap 124 between the vent wall 122 and the interior surface 114 of the exhaust stack 102; and (ii) at least one opening 122c in the interior surface 114 of the exhaust stack 102 between the top 122a and bottom 122b portions of the vent wall 122. A transfer pipe 128 is connected to the at least one opening 122c in the interior surface 114 of the exhaust stack 102 to remove the high molecular weight gases 112 from the interior vent 122. The at least one or more openings 122c can be holes, slots, or any other geometrically shaped passageway. Moreover, more than one transfer pipe 128 can be used. The lower portion 122b of the vent wall 122 can be substantially parallel to the interior surface 114 of the exhaust stack 102, curved or angled with respect to the interior surface 114 of the exhaust stack 102. Note that the top portion 122a of the interior vent 122 does not have to be aligned with a horizontal plane of the exhaust stack 102. For example, the top portion 122a can be angled from the horizontal plane in accordance with the tangential flow 110 (top portion 122a on the opposite side of the exhaust stack 102 from the opening 122c positioned lower than the top portion 112a adjacent to the opening 122c). For example, the top portion 122a can form one or more spirals down from the one or more openings 122c. In addition, an optional baffle or guide 122d proximate to the at least one opening 122c can be used to direct the flow of the high molecular weight gases 112 from the interior vent 122 into the transfer pipe 128. The baffle or guide 122d can be straight, angled, curved or any other shape and orientation to more efficiently guide the high molecular weight gasses 112 into the transfer pipe 128.

The dimensions (A, B, C, D) of the vent wall 122 will vary in accordance with the design specifications for the system 100. The design specification may take into account one or more parameters, such as temperature, humidity, velocity, gas composition, fuel type, or exhaust gas mixture. The system 100 dimensions should be configured to concentrate and capture at least 85% of the high molecular weight gases. The at least one opening 122c is positioned at a height (A) such that the high molecular weight gases 112 have spun around the exhaust stack 102 approximately fifteen to twenty times or more. In one example, the at least one opening 122c is positioned at a height (A) above the bottom of the exhaust stack 102 approximately equal to three diameters ( $3xD$ ) of the exhaust stack 102, the annular space or gap 124 has an area (B) of approximately 10% of a cross-sectional area of the exhaust stack 102, and the bottom portion 122a of the vent wall 122

extends down a distance (C) approximately equal to one half diameter ( $0.5 \times D$ ) of the exhaust stack 102.

The system 100 may also include other components, such as a tank (504, FIGURE 5) connected to the transfer pipe 128 to store the removed high molecular weight gases 112, a compressor attached to the transfer pipe 128 to compress the removed high molecular weight gases 112 (506, FIGURE 5), a motor attached to the vent wall 122 that adjusts a size of the annular space or gap 124 based on one or more parameters (e.g., temperature, humidity, velocity, gas composition, fuel type, or exhaust gas mixture, etc.), and/or one or more sensors attached to the blower 106, exhaust stack 102, interior vent 122 or transfer pipe 128. A controller can be communicably coupled to the motor and the one or more sensors to adjust the size (B) of the annular space or gap 124 using the motor based on one or more parameters detected by the one or more sensors. As previously discussed, one or more bubble trays (508, FIGURE 5) containing sodium hydroxide can be attached to the transfer pipe 128 or tank such that the removed CO<sub>2</sub> is combined with the sodium hydroxide to produce sodium carbonate.

Referring now to FIGURES 2A, 2B and 2C, a cross-sectional side view (FIGURE 2A), a cross-sectional top view at cross section E-E (FIGURE 2B) and a cross-sectional bottom view at cross section F-F (FIGURE 2C) of the system 200 for separating high molecular weight (HMW) gases 112 in an exhaust stack 102 from an exhaust gas 104 of a combustion source in accordance with one embodiment of the present invention are shown. A blower 106 is attached to an intake 108 of the exhaust stack 102 to receive the exhaust gas 104 from the combustion source (502, FIGURE 5) and create a tangential flow 110 of the exhaust gas 104 within the exhaust stack 102. The blower 106 imparts sufficient centrifugal force on the exhaust gas 104 to concentrate the high molecular weight gases 112, such as CO<sub>2</sub> or other gases having a higher molecular weight greater than N<sub>2</sub> or O<sub>2</sub> (e.g., greater than 35), along the inner perimeter or surface 114 of the exhaust stack 102. Typically, the blower 106 causes the exhaust gases 104 to spin around the interior of the exhaust stack 102 at least five times within a height approximately equal to one diameter (D) of the exhaust stack 102. As shown, the blower 106 is external to the exhaust stack 102 and is connected to the intake 108 of the exhaust stack 102 with a first pipe 116. A second pipe 118 connects the blower 106 to the bottom of the exhaust stack 102 at a point approximately opposite to the intake 108 and in line with the tangential flow 110 in order to create the sufficient centrifugal force on the exhaust gas 104. The use of a

stationary tubulator, or spin vanes, or actual in-stack centrifuge may be necessary in addition to the blower 106.

An interior vent 122 within the exhaust stack 102 collects the high molecular weight gases 112 concentrated along the inner surface 114 of the exhaust stack 102. The interior vent 122 includes: (i) a vent wall having a top portion 122a attached to the interior surface 114 of the exhaust stack 102 along the entire inner perimeter of the exhaust stack 102 (e.g., the top portion 122a is attached to the inner surface 114 along any side cross section of the exhaust stack 102) and a lower portion 122b that extends downward into the exhaust stack 102 to form an annular space or gap 124 between the vent wall 122 and the interior surface 114 of the exhaust stack 102; (ii) at least one opening 122c in the interior surface 114 of the exhaust stack 102 between the top 122a and bottom 122b portions of the vent wall 122; and (iii) a bustle 202 attached to or integrated into the exhaust stack 102 between the at least one opening 122c in the inner surface 114 of the exhaust stack 102 and a transfer pipe 128. The transfer pipe 128 is connected to bustle 202 to remove the high molecular weight gases 112 from the interior vent 122. The at least one or more openings 122c can be holes, slots, or any other geometrically shaped passageway. Moreover, more than one transfer pipe 128 can be used. The lower portion 122b of the vent wall 122 can be substantially parallel to the interior surface 114 of the exhaust stack 102, curved or angled with respect to the interior surface 114 of the exhaust stack 102. Note that the top portion 122a of the interior vent 122 does not have to be aligned with a horizontal plane of the exhaust stack 102. For example, the top portion 122a can be angled from the horizontal plane in accordance with the tangential flow 110 (top portion 122a on the opposite side of the exhaust stack 102 from the opening 122c positioned lower than the top portion 112a adjacent to the opening 122c). For example, the top portion 122a can form one or more spirals down from the one or more openings 122c. In addition, an optional baffle or guide 122d proximate to the at least one opening 122c can be used to direct the flow of the high molecular weight gases 112 from the interior vent 122 into the transfer pipe 128. The baffle or guide 122d can be straight, angled, curved or any other shape and orientation to more efficiently guide the high molecular weight gasses 112 into the transfer pipe 128.

The dimensions (A, B, C, D) of the vent wall 122 will vary in accordance with the design specifications for the system 200. The design specification may take into account one or more parameters, such as temperature, humidity, velocity, gas composition, fuel type, or exhaust gas mixture. The system 200 dimensions should be configured to

concentrate and capture at least 85% of the high molecular weight gases. The at least one opening 122c is positioned at a height (A) such that the high molecular weight gases 112 have spun around the exhaust stack 102 approximately fifteen to twenty times or more. In one example, the at least one opening 122c is positioned at a height (A) above the bottom  
5 of the exhaust stack 102 approximately equal to three diameters ( $3xD$ ) of the exhaust stack 102, the annular space or gap 124 has an area (B) of approximately 10% of a cross-sectional area of the exhaust stack 102, and the bottom portion 122a of the vent wall 122 extends down a distance (C) approximately equal to one half diameter ( $0.5xD$ ) of the exhaust stack 102.

10 The system 100 may also include other components, such as a tank (504, FIGURE 5) connected to the transfer pipe 128 to store the removed high molecular weight gases 112, a compressor attached to the transfer pipe 128 to compress the removed high molecular weight gases 112 (506, FIGURE 5), a motor attached to the vent wall 122 that adjusts a size of the annular space or gap 124 based on one or more parameters (e.g.,  
15 temperature, humidity, velocity, gas composition, fuel type, or exhaust gas mixture, etc.), and/or one or more sensors attached to the blower 106, exhaust stack 102, interior vent 122 or transfer pipe 128. A controller can be communicably coupled to the motor and the one or more sensors to adjust the size (B) of the annular space or gap 124 using the motor based on one or more parameters detected by the one or more sensors. As previously  
20 discussed, one or more bubble trays (508, FIGURE 5) containing sodium hydroxide can be attached to the transfer pipe 128 or tank such that the removed  $CO_2$  is combined with the sodium hydroxide to produce sodium carbonate.

Now referring to FIGURES 3A, 3B and 3C, a cross sectional side view (FIGURE 3A), a cross-sectional top view at cross section E-E (FIGURE 3B) and a cross-sectional  
25 bottom view at cross section F-F (FIGURE 3C) of the system 300 for separating high molecular weight (HMW) gases in an exhaust stack 102 from an exhaust gas 104 of a combustion source in accordance with one embodiment of the present invention are shown. A blower 106 is attached to an intake 108 of the exhaust stack 102 to receive the exhaust gas 104 from the combustion source (502, FIGURE 5) and create a tangential flow 110 of  
30 the exhaust gas 104 within the exhaust stack 102. The blower 106 imparts sufficient centrifugal force on the exhaust gas 104 to concentrate the high molecular weight gases 112, such as  $CO_2$  or other gases having a higher molecular weight greater than  $N_2$  or  $O_2$  (e.g., greater than 35), along the inner perimeter or surface 114 of the exhaust stack 102.

Typically, the blower 106 causes the exhaust gases 104 to spin around the interior of the exhaust stack 102 at least five times within a height approximately equal to one diameter (D) of the exhaust stack 102. As shown, the blower 106 is internal to the exhaust stack 102. A second pipe 118 or channel connects the blower 106 to the bottom of the exhaust stack 102 at a point 120 approximately opposite to the intake 108 and in line with the tangential flow 110 in order to create the sufficient centrifugal force on the exhaust gas 104. The use of a stationary tubulator, or spin vanes, or actual in-stack centrifuge may be necessary in addition to the blower 106.

An interior vent 122 within the exhaust stack 102 collects the high molecular weight gases 112 concentrated along the inner surface 114 of the exhaust stack 102. The interior vent 122 includes: (i) a vent wall having a top portion 122a attached to the interior surface 114 of the exhaust stack 102 along the entire inner perimeter of the exhaust stack 102 (e.g., the top portion 122a is attached to the inner surface 114 along any side cross section of the exhaust stack 102) and a lower portion 122b that extends downward into the exhaust stack 102 to form an annular space or gap 124 between the vent wall 122 and the interior surface 114 of the exhaust stack 102; (ii) at least one opening 122c in the interior surface 114 of the exhaust stack 102 between the top 122a and bottom 122b portions of the vent wall 122; and (iii) a bustle 202 attached to or integrated into the exhaust stack 102 between the at least one opening 122c in the inner surface 114 of the exhaust stack 102 and a transfer pipe 128. The transfer pipe 128 is connected to bustle 202 to remove the high molecular weight gases 112 from the interior vent 122. The at least one or more openings 122c can be holes, slots, or any other geometrically shaped passageway. Moreover, more than one transfer pipe 128 can be used. The lower portion 122b of the vent wall 122 can be substantially parallel to the interior surface 114 of the exhaust stack 102, curved or angled with respect to the interior surface 114 of the exhaust stack 102. Note that the top portion 122a of the interior vent 122 does not have to be aligned with a horizontal plane of the exhaust stack 102. For example, the top portion 122a can be angled from the horizontal plane in accordance with the tangential flow 110 (top portion 122a on the opposite side of the exhaust stack 102 from the opening 122c positioned lower than the top portion 112a adjacent to the opening 122c). For example, the top portion 122a can form one or more spirals down from the one or more openings 122c. In addition, an optional baffle or guide 122d proximate to the at least one opening 122c can be used to direct the flow of the high molecular weight gases 112 from the interior vent 122 into the transfer pipe 128. The

baffle or guide 122d can be straight, angled, curved or any other shape and orientation to more efficiently guide the high molecular weight gasses 112 into the transfer pipe 128).

The dimensions (A, B, C, D) of the vent wall 122 will vary in accordance with the design specifications for the system 300. The design specification may take into account one or more parameters, such as temperature, humidity, velocity, gas composition, fuel type, or exhaust gas mixture. The system 300 dimensions should be configured to concentrate and capture at least 85% of the high molecular weight gases. The at least one opening 122c is positioned at a height (A) such that the high molecular weight gases 112 have spun around the exhaust stack 102 approximately fifteen to twenty times or more. In one example, the at least one opening 122c is positioned at a height (A) above the bottom of the exhaust stack 102 approximately equal to three diameters ( $3xD$ ) of the exhaust stack 102, the annular space or gap 124 has an area (B) of approximately 10% of a cross-sectional area of the exhaust stack 102, and the bottom portion 122a of the vent wall 122 extends down a distance (C) approximately equal to one half diameter ( $0.5xD$ ) of the exhaust stack 102.

The system 100 may also include other components, such as a tank (504, FIGURE 5) connected to the transfer pipe 128 to store the removed high molecular weight gases 112, a compressor attached to the transfer pipe 128 to compress the removed high molecular weight gases 112 (506, FIGURE 5), a motor attached to the vent wall 122 that adjusts a size of the annular space or gap 124 based on one or more parameters (e.g., temperature, humidity, velocity, gas composition, fuel type, or exhaust gas mixture, etc.), and/or one or more sensors attached to the blower 106, exhaust stack 102, interior vent 122 or transfer pipe 128. A controller can be communicably coupled to the motor and the one or more sensors to adjust the size (B) of the annular space or gap 124 using the motor based on one or more parameters detected by the one or more sensors. As previously discussed, one or more bubble trays (508, FIGURE 5) containing sodium hydroxide can be attached to the transfer pipe 128 or tank such that the removed  $\text{CO}_2$  is combined with the sodium hydroxide to produce sodium carbonate.

Referring now to FIGURE 4, a flow chart of a method 400 for separating high molecular weight gases in an exhaust stack from an exhaust gas of a combustion source in accordance with one embodiment of the present invention is shown. The following components are provided in block 402 to perform the method 400: (a) a blower attached to an intake of an exhaust stack to receive the exhaust gas from the combustion source, (b) an

interior vent within the exhaust stack comprising (i) a vent wall having a top portion attached to the interior surface of the exhaust stack along the entire inner perimeter of the exhaust stack and a lower portion that extends downward into the exhaust stack to form an annular space or gap between the vent wall and the interior surface of the exhaust stack, and (ii) at least one opening in the interior surface of the exhaust stack between the top and bottom portions of the vent wall, and (c) a transfer pipe connected to the at least one opening in the interior surface of the exhaust stack. A tangential flow of the exhaust gas within the exhaust stack is created using the blower in block 404. The blower imparts sufficient centrifugal force on the exhaust gas to concentrate substantially all of the high molecular weight gases along the inner surface of the exhaust stack. The high molecular weight gases concentrated along the inner surface of the exhaust stack are collected using the interior vent in block 406. The high molecular weight gases are removed from the interior vent using the transfer pipe in block 408.

Additional steps may include storing the removed high molecular weight gases in a tank (504, FIGURE 5) connected to the transfer pipe, compressing the removed high molecular weight gases (506, FIGURE 5), injecting the removed high molecular weight gases into a below-ground storage, or flowing the removed CO<sub>2</sub> up through one or more bubble trays containing sodium hydroxide which causes the removed CO<sub>2</sub> to combine with the sodium hydroxide to produce sodium carbonate (508, FIGURE 5).

Now referring to FIGURE 5, a block diagram of a system 500 incorporating the embodiments of the present invention is shown. As previously described, the combustion source 502 creates exhaust 104, which is transported to the exhaust stack 100, 200 or 300. Low molecular gas 130 exits the exhaust stack 100, 200 or 300. The high molecular weight gas 112 is collected and removed from the exhaust stack 100, 200 or 300 for further processing (e.g., storage in a tank 504, compression followed by storage 506, bubble trays to produce sodium carbonate 508, etc.). The high molecular weight gas 112 can be used in other ways as will be appreciated and known by those skilled in the art.

The various illustrative logical blocks, modules, circuits, and algorithm steps described herein may be implemented as electronic hardware, computer software, or combinations of both, depending on the application and functionality. Moreover, the various logical blocks, modules, and circuits described herein may be implemented or performed with a general purpose processor (e.g., microprocessor, conventional processor, controller, microcontroller, state machine or combination of computing devices), a digital

signal processor (“DSP”), an application specific integrated circuit (“ASIC”), a field programmable gate array (“FPGA”) or other programmable logic device, discrete gate or transistor logic, discrete hardware components, or any combination thereof designed to perform the functions described herein. Similarly, steps of a method or process described

5 herein may be embodied directly in hardware, in a software module executed by a processor, or in a combination of the two. A software module may reside in RAM memory, flash memory, ROM memory, EPROM memory, EEPROM memory, registers, hard disk, a removable disk, a CD-ROM, or any other form of storage medium known in the art. Although preferred embodiments of the present invention have been described in

10 detail, it will be understood by those skilled in the art that various modifications can be made therein without departing from the spirit and scope of the invention as set forth in the appended claims.



**CLAIMS**

1. A method for separating high molecular weight gases from an exhaust gas of a combustion source comprising the steps of:

- 5 providing (a) a blower attached to an intake of an exhaust stack to receive the exhaust gas from the combustion source, (b) an interior vent within the exhaust stack comprising (i) a vent wall having a top portion attached to the interior surface of the exhaust stack along the entire inner perimeter of the exhaust stack and a lower portion that extends downward into the exhaust stack to form a gap between the vent wall and the
- 10 interior surface of the exhaust stack, and (ii) at least one opening in the interior surface of the exhaust stack between the top and bottom portions of the vent wall, and (c) a transfer pipe connected to the at least one opening in the interior surface of the exhaust stack;
- creating a tangential flow of the exhaust gas within the exhaust stack using the blower, wherein the blower imparts sufficient centrifugal force on the exhaust gas to
- 15 concentrate substantially all of the high molecular weight gases along the inner surface of the exhaust stack;
- collecting the high molecular weight gases concentrated along the inner surface of the exhaust stack using the interior vent; and
- removing the high molecular weight gases from the interior vent using the transfer
- 20 pipe.

2. The method as recited in claim 1, further comprising the steps of:

- storing the removed high molecular weight gases in a tank connected to the transfer pipe;
- 25 compressing the removed high molecular weight gases; or
- injecting the removed high molecular weight gases into a below-ground storage.

3. The method as recited in claim 1, wherein the high molecular weight gases have a molecular weight greater than 35.

30

4. The method as recited in claim 1, wherein the high molecular weight gases comprise CO<sub>2</sub>.

5. The method as recited in claim 4, further comprising the step of flowing the removed CO<sub>2</sub> up through one or more bubble trays containing sodium hydroxide which causes the removed CO<sub>2</sub> to combine with the sodium hydroxide to produce sodium carbonate.

5

6. The method as recited in claim 1, wherein;  
the sufficient centrifugal force is provided by the blower in combination with a stationary tabulator, spin vanes, or in-stack centrifuge; and  
the blower is located inside or outside of the exhaust stack.

10

7. The method as recited in claim 1, further comprising a bustle attached to or integrated into the exhaust stack between the at least one opening in the inner surface of the exhaust stack and the transfer pipe.

15

8. The method as recited in claim 1, wherein the vent wall is substantially parallel to the interior surface of the exhaust stack, curved or is angled with respect to the interior surface of the exhaust stack

9. The method as recited in claim 1, wherein at least 85% of the high molecular weight gases are concentrated along the inner surface of the exhaust stack.

20

10. The method as recited in claim 1, wherein the gap comprises an area of approximately 10% of a cross-sectional area of the exhaust stack.

11. The method as recited in claim 1, wherein the at least one opening is positioned such that the high molecular weight gases have spun around the exhaust stack approximately fifteen to twenty times.

25

12. The method as recited in claim 1, wherein the blower causes the exhaust gases to spin around the exhaust stack at least five times within a height approximately equal to one diameter of the exhaust stack.

30

13. The method as recited in claim 1, wherein the at least one opening is positioned at a height above the bottom of the exhaust stack approximately equal to three diameters of the exhaust stack.

5 14. The method as recited in claim 1, wherein the bottom portion of the vent wall extends down to a height above the bottom of the exhaust stack approximately equal to one half diameter of the exhaust stack.

10 15. The method as recited in claim 1, further comprising a motor attached to the vent wall that adjusts a size of the gap.

16. The method as recited in claim 15, wherein the motor is used to adjust the size of the gap based on one or more parameters comprising temperature, humidity, velocity, gas composition, fuel type, or exhaust gas mixture.

15

17. The method as recited in claim 15, further comprising:  
one or more sensors attached to the blower, exhaust stack, interior vent or transfer pipe; and

20 a controller communicably coupled to the motor and the one or more sensors,  
wherein the controller to adjusts the size of the gap using the motor based on one or more parameters detected by the one or more sensors.

18. A system for separating high molecular weight gases in an exhaust stack from an exhaust gas of a combustion source comprising:

25 a blower attached to an intake of the exhaust stack to receive the exhaust gas from the combustion source and create a tangential flow of the exhaust gas within the exhaust stack, wherein the blower imparts sufficient centrifugal force on the exhaust gas to concentrate the high molecular weight gases along the inner surface of the exhaust stack;

an interior vent within the exhaust stack that collects the high molecular weight gases concentrated along the inner surface of the exhaust stack, the interior vent comprising (i) a vent wall having a top portion attached to the interior surface of the exhaust stack along the entire inner perimeter of the exhaust stack and a lower portion that extends downward into the exhaust stack to form a gap between the vent wall and the interior surface of the exhaust stack, and (ii) at least one opening in the interior surface of the exhaust stack between the top and bottom portions of the vent wall; and

a transfer pipe connected to the at least one opening in the interior surface of the exhaust stack to remove the high molecular weight gases from the interior vent.

10

19. The system as recited in claim 18, further comprising:

a tank connected to the transfer pipe; or

a compressor attached to the transfer pipe to compress the removed high molecular weight gases.

15

20. The system as recited in claim 18, wherein the high molecular weight gases have a molecular weight greater than 35.

21. The system as recited in claim 18, wherein the high molecular weight gases comprise CO<sub>2</sub>.

20

22. The system as recited in claim 21, further comprising one or more bubble trays containing sodium hydroxide attached to the transfer pipe such that the removed CO<sub>2</sub> is combined with the sodium hydroxide to produce sodium carbonate.

25

23. The system as recited in claim 18, wherein:

the sufficient centrifugal force is provided by the blower in combination with a stationary tabulator, spin vanes, or in-stack centrifuge; and

the blower is located inside or outside of the exhaust stack.

30

24. The system as recited in claim 18, further comprising a baffle attached to or integrated into the exhaust stack between the at least one opening in the inner surface of the exhaust stack and the transfer pipe.

25. The system as recited in claim 18, wherein the vent wall is substantially parallel to the interior surface of the exhaust stack, curved or is angled with respect to the interior surface of the exhaust stack.

5

26. The system as recited in claim 18, wherein at least 85% of the high molecular weight gases are concentrated along the inner surface of the exhaust stack.

10

27. The system as recited in claim 18, wherein the gap comprises an area of approximately 10% of a cross-sectional area of the exhaust stack.

28. The system as recited in claim 18, wherein the at least one opening is positioned such that the high molecular weight gases have spun around the exhaust stack approximately fifteen to twenty times.

15

29. The system as recited in claim 18, wherein the blower causes the exhaust gases to spin around the exhaust stack at least five times within a height approximately equal to one diameter of the exhaust stack.

20

30. The system as recited in claim 18, wherein the at least one opening is positioned at a height above the bottom of the exhaust stack approximately equal to three diameters of the exhaust stack.

25

31. The system as recited in claim 18, wherein the bottom portion of the vent wall extends down to a height above the bottom of the exhaust stack approximately equal to one half diameter of the exhaust stack.

30

32. The system as recited in claim 18, further comprising a motor attached to the vent wall that adjusts a size of the gap.

33. The system as recited in claim 32, wherein the motor is used to adjust the size of the gap based on one or more parameters comprising temperature, humidity, velocity, gas composition, fuel type, or exhaust gas mixture.

34. The system as recited in claim 32, further comprising:

one or more sensors attached to the blower, exhaust stack, interior vent or transfer pipe; and

5 a controller communicably coupled to the motor and the one or more sensors, wherein the controller to adjusts the size of the gap using the motor based on one or more parameters detected by the one or more sensors.

35. A system for separating high molecular weight gases from an exhaust gas of a combustion source comprising:

10 an exhaust stack;

a blower attached to an intake of the exhaust stack to receive the exhaust gas from the combustion source and create a tangential flow of the exhaust gas within the exhaust stack, wherein the blower imparts sufficient centrifugal force on the exhaust gas to

15 concentrate the high molecular weight gases along the inner surface of the exhaust stack;

an interior vent within the exhaust stack that collects the high molecular weight gases concentrated along the inner surface of the exhaust stack, the interior vent comprising (i) a vent wall having a top portion attached to the interior surface of the exhaust stack along the entire inner perimeter of the exhaust stack and a lower portion that extends downward into the exhaust stack to form a gap between the vent wall and the interior surface of the exhaust stack, and (ii) at least one opening in the interior surface of the exhaust stack between the top and bottom portions of the vent wall; and

20 a transfer pipe connected to the at least one opening in the interior surface of the exhaust stack to remove the high molecular weight gases from the interior vent; and

25 wherein (a) the high molecular weight gases have a molecular weight greater than 35, (b) at least 85% of the high molecular weight gases are concentrated along the inner surface of the exhaust stack, (c) the gap comprises an area of approximately 10% of a cross-sectional area of the exhaust stack, (d) the at least one opening is positioned at a height above the bottom of the exhaust stack approximately equal to three diameters of the exhaust stack, and (e) the blower causes the exhaust gases to spin around the exhaust stack at least five times within a height approximately equal to one diameter of the exhaust stack.

36. The system as recited in claim 35, further comprising:

a tank connected to the transfer pipe; or  
a compressor attached to the transfer pipe to compress the removed high molecular weight gases.

- 5 37. The system as recited in claim 35, wherein the high molecular weight gases comprise CO<sub>2</sub>.
38. The system as recited in claim 37, further comprising one or more bubble trays containing sodium hydroxide attached to the transfer pipe such that the removed CO<sub>2</sub> is  
10 combined with the sodium hydroxide to produce sodium carbonate.
39. The method as recited in claim 35, wherein:  
the sufficient centrifugal force is provided by the blower in combination with a stationary tabulator, spin vanes, or in-stack centrifuge; and  
15 the blower is located inside or outside of the exhaust stack.
40. The system as recited in claim 35, further comprising a bustle attached to or integrated into the exhaust stack between the at least one opening in the inner surface of the exhaust stack and the transfer pipe.  
20
41. The system as recited in claim 35, wherein the vent wall is substantially parallel to the interior surface of the exhaust stack, curved or is angled with respect to the interior surface of the exhaust stack.
- 25 42. The system as recited in claim 35, wherein the bottom portion of the vent wall extends down to a height above the bottom of the exhaust stack approximately equal to one half diameter of the exhaust stack.
43. The system as recited in claim 35, further comprising a motor attached to the vent  
30 wall that adjusts a size of the gap.

44. The system as recited in claim 43, wherein the motor is used to adjust the size of the gap based on one or more parameters comprising temperature, humidity, velocity, gas composition, fuel type, or exhaust gas mixture.

- 5 45. The system as recited in claim 43, further comprising:  
one or more sensors attached to the blower, exhaust stack, interior vent or transfer  
pipe; and  
a controller communicably coupled to the motor and the one or more sensors,  
wherein the controller to adjusts the size of the gap using the motor based on one or more  
10 parameters detected by the one or more sensors.



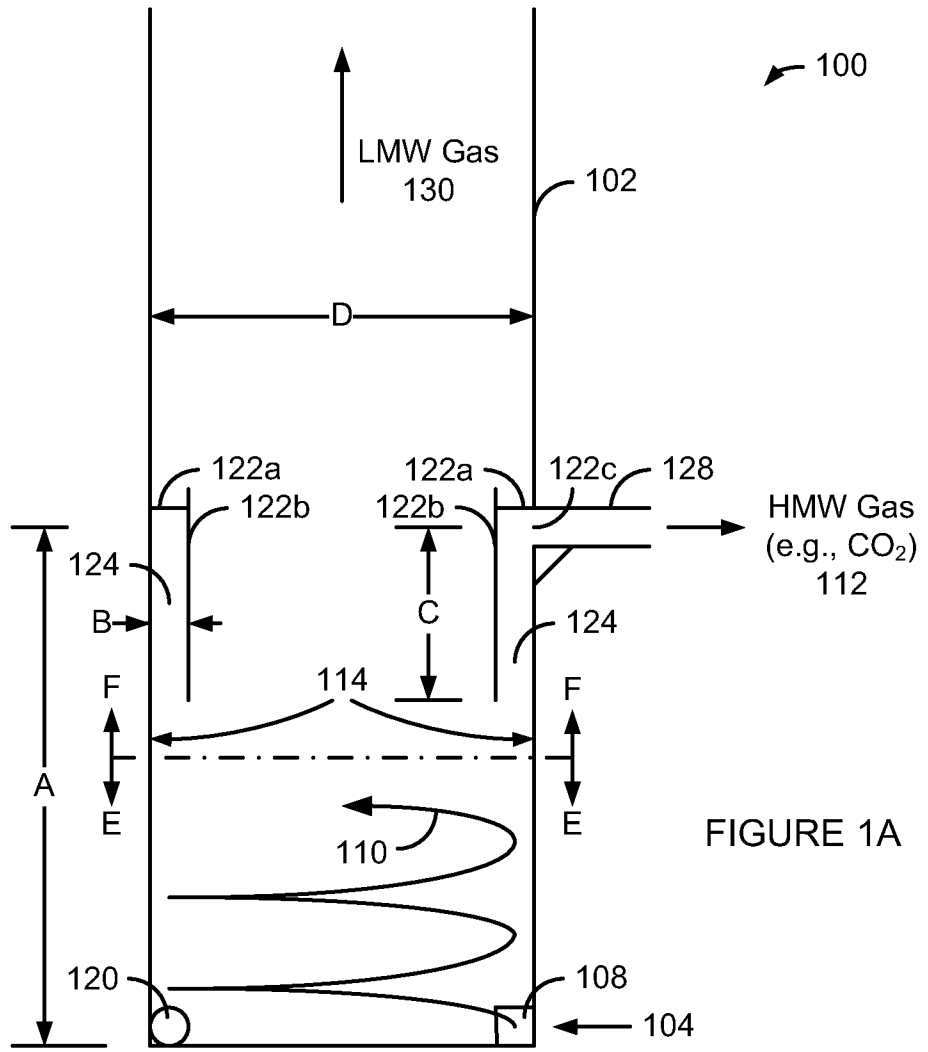

FIGURE 1A

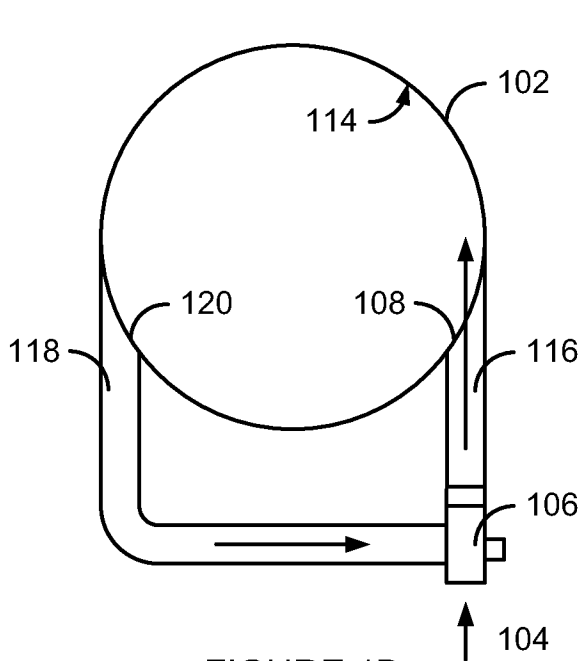

FIGURE 1B  
CROSS SECTION E-E

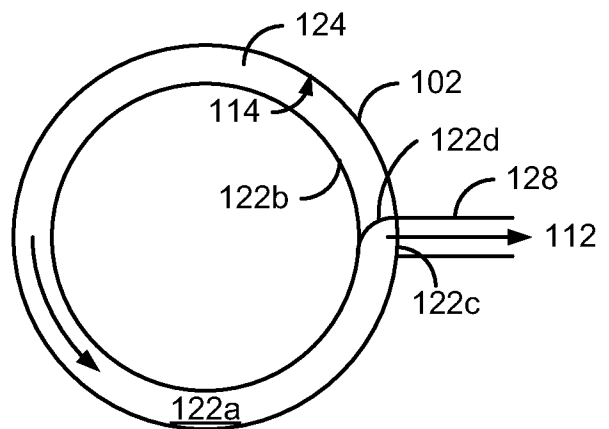

FIGURE 1C  
CROSS SECTION F-F

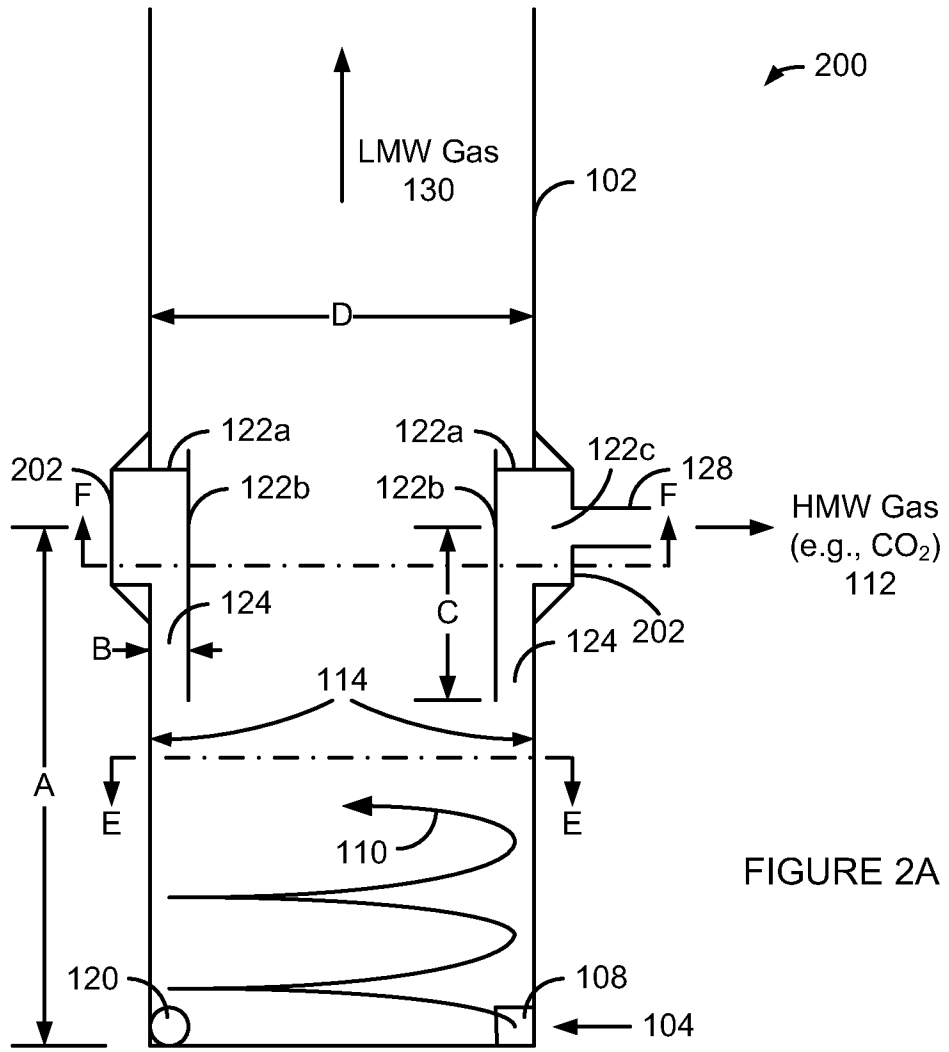

FIGURE 2A

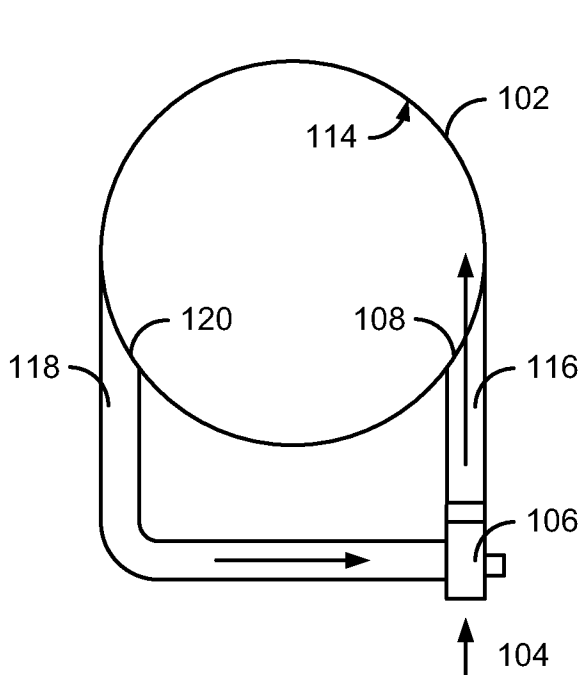

FIGURE 2B  
CROSS SECTION E-E

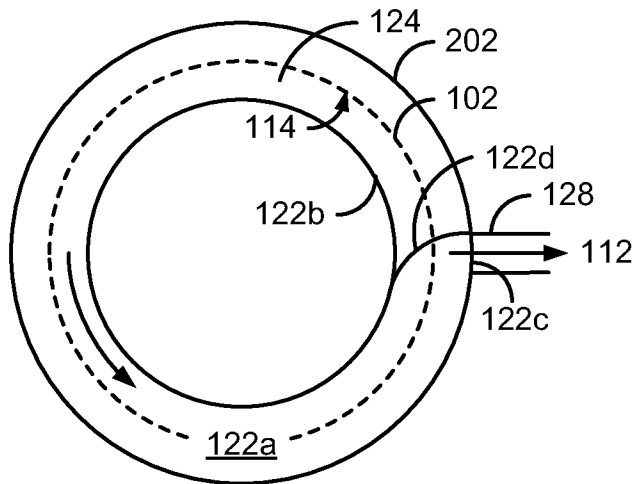

FIGURE 2C  
CROSS SECTION F-F

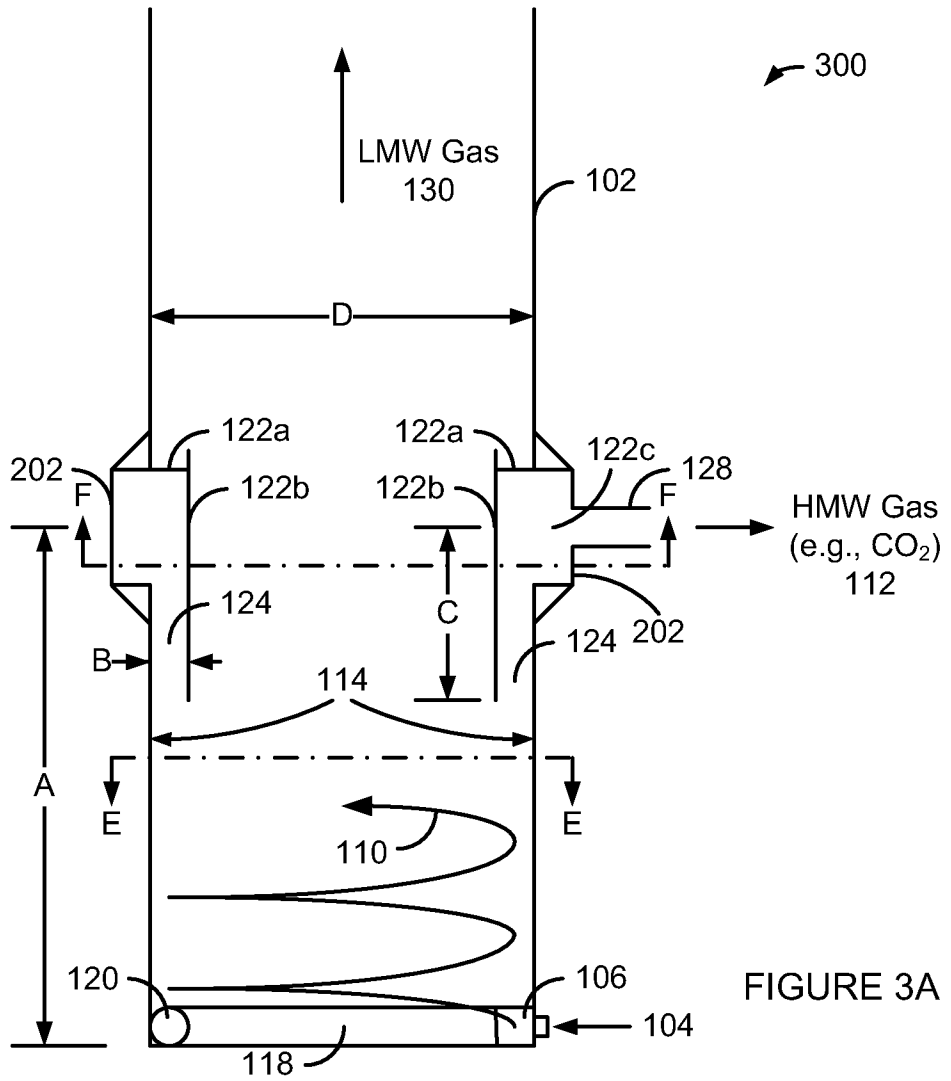

FIGURE 3A

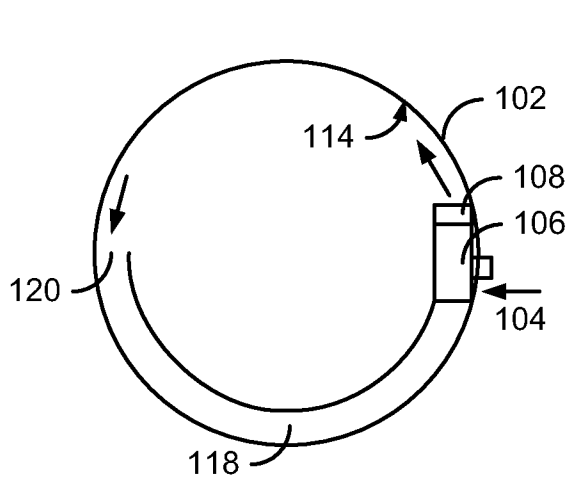

FIGURE 3B  
CROSS SECTION E-E

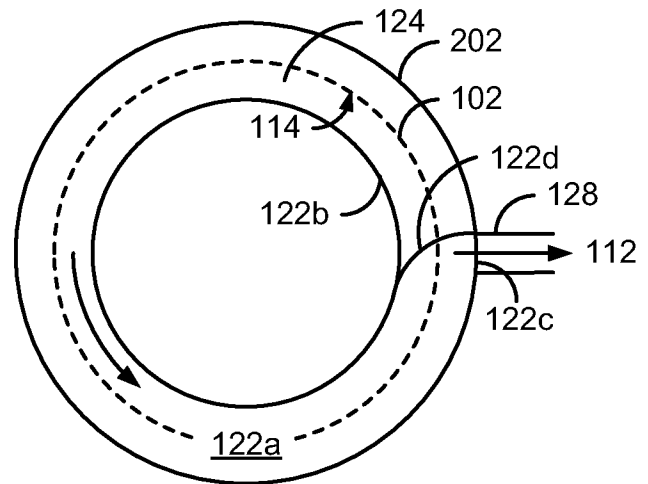

FIGURE 3C  
CROSS SECTION F-F

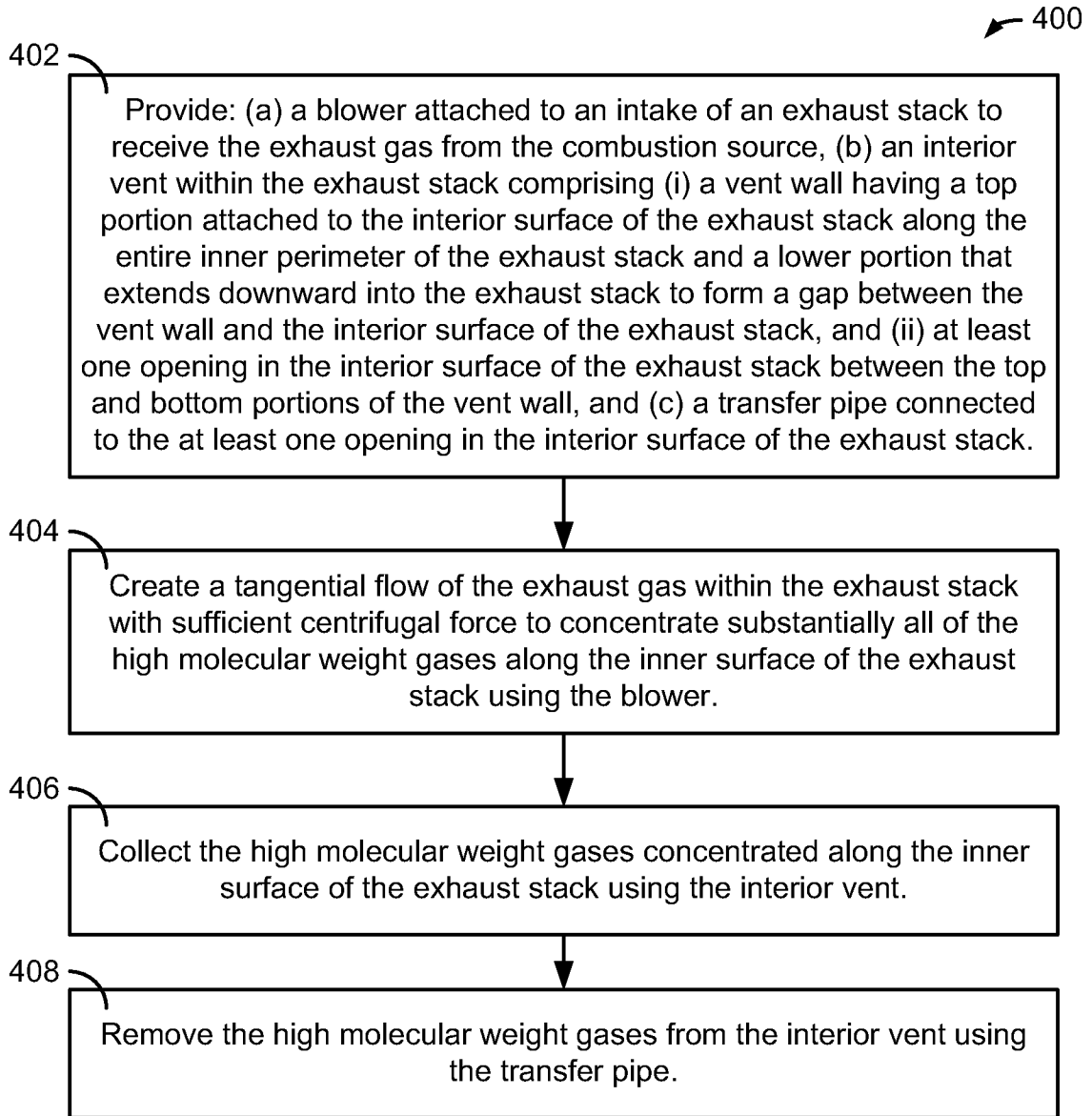

FIGURE 4

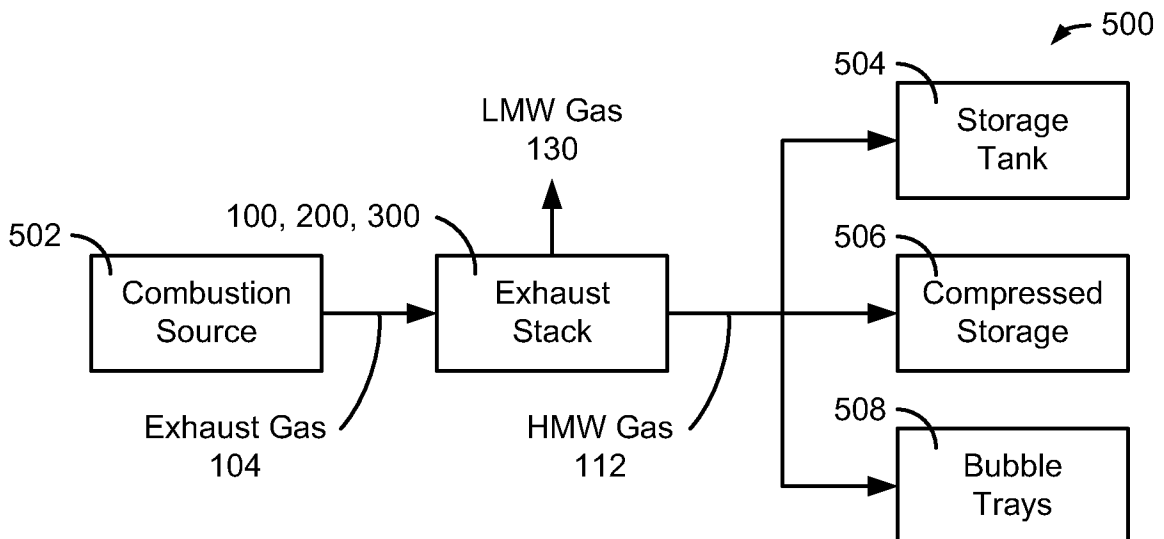

FIGURE 5