

March 30, 1937.

R. C. CURTIS

2,075,181

RECEPTION SYSTEM

Filed June 12, 1934

3 Sheets-Sheet 1

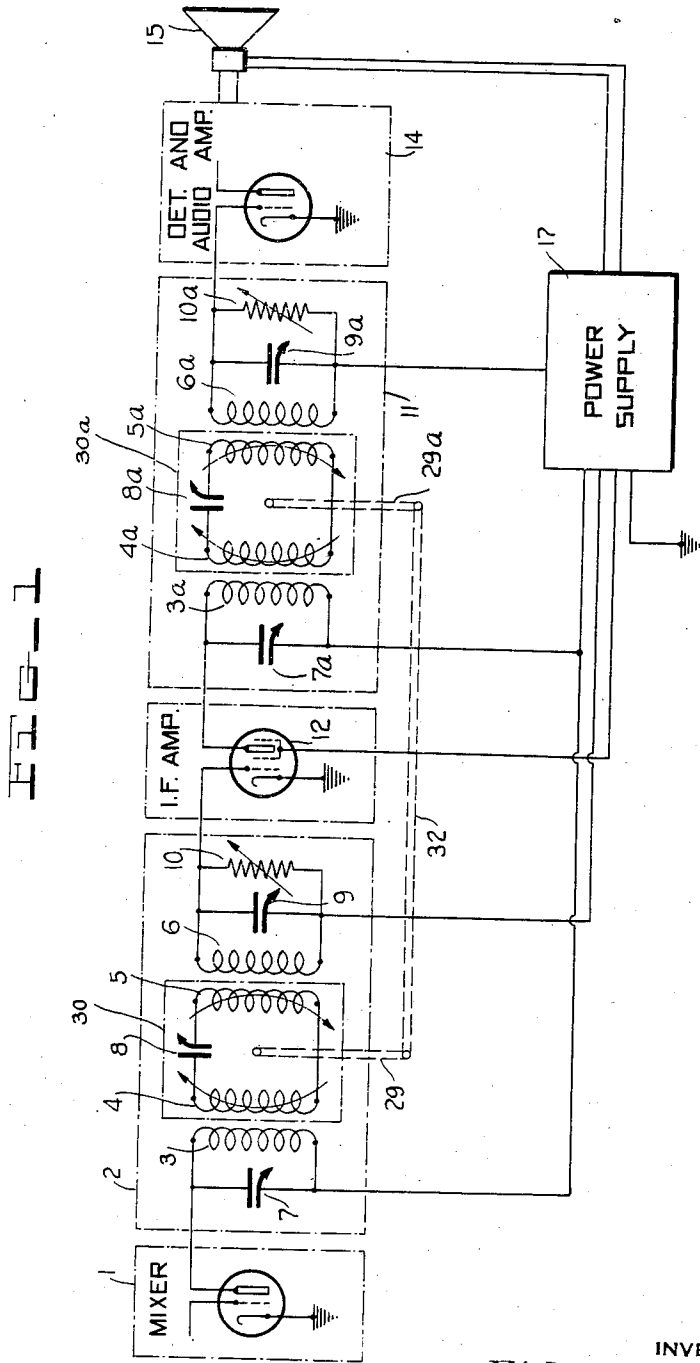

FIG. 1

INVENTOR  
**Richard C. Curtis**  
BY  
*Wm. J. Herdman*  
ATTORNEY

March 30, 1937.

R. C. CURTIS

2,075,181

RECEPTION SYSTEM

Filed June 12, 1934

3 Sheets-Sheet 2

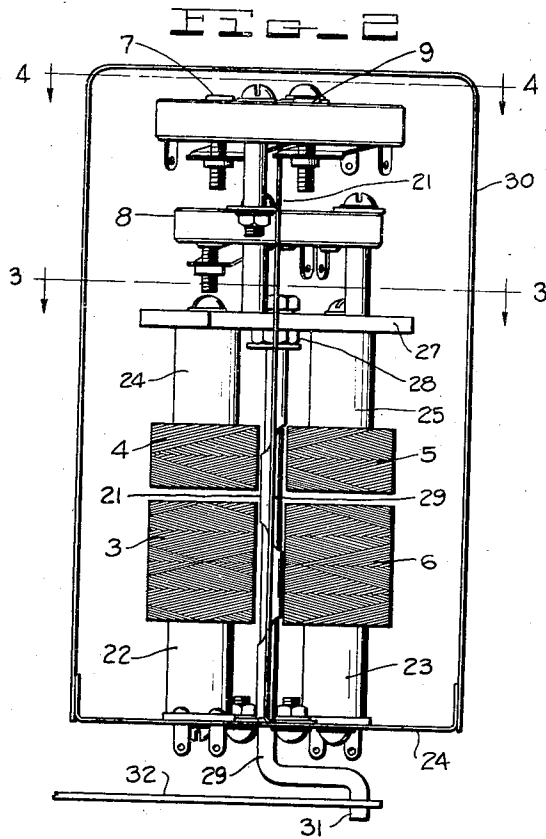

Fig. 3

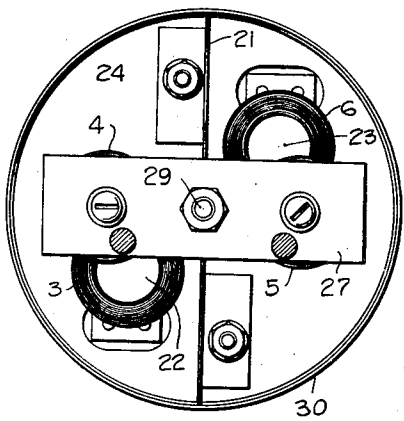
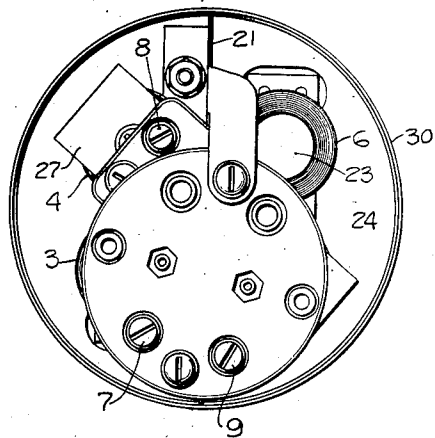

Fig. 4



INVENTOR  
Richard C. Curtis

BY  
*Wm. J. Herdman*  
ATTORNEY

March 30, 1937.

R. C. CURTIS

2,075,181

RECEPTION SYSTEM

Filed June 12, 1934

3 Sheets-Sheet 3

FIG. 5

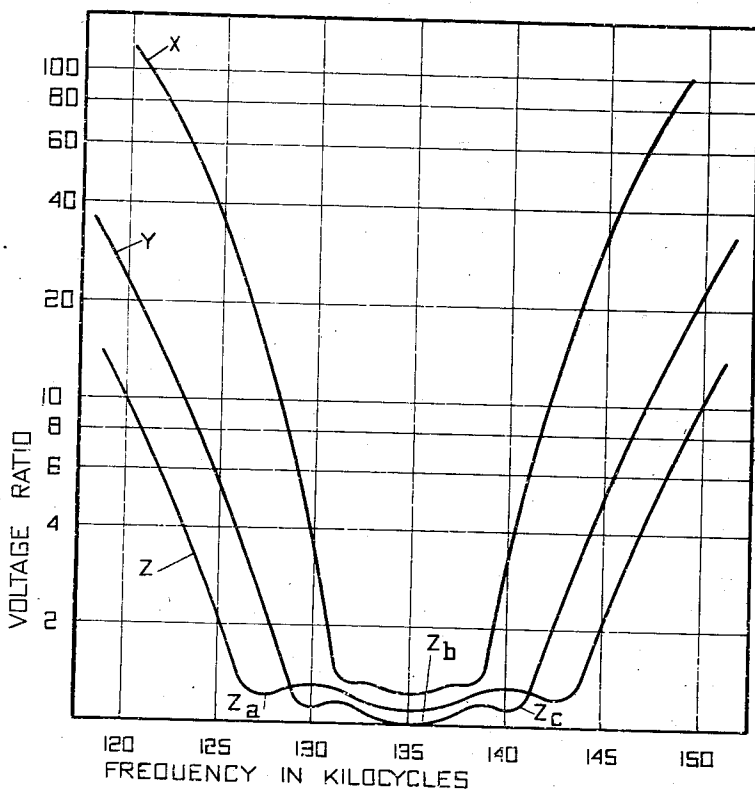

INVENTOR  
**Richard C. Curtis**  
BY  
*Wm. J. Herdman*  
ATTORNEY

# UNITED STATES PATENT OFFICE

2,075,181

## RECEPTION SYSTEM

Richard C. Curtis, East Orange, N. J., assignor to  
Wired Radio, Inc., New York, N. Y., a corpora-  
tion of Delaware

Application June 12, 1934, Serial No. 730,211

6 Claims. (Cl. 178-44)

My invention pertains in general to radio receiving systems and specifically relates to a universal receiver for receiving programs under varying conditions.

5 One of the objects of my invention consists in providing a radio receiving system having means for effecting the reception of signals from differently characterized sources.

10 Another object comprises providing a receiving system having means for improving the quality of reproduction by having a plural resonance accentuation of the response at certain frequencies.

15 A further object comprises providing a filter system of the inductively coupled type in which variation of frequency band width can be accomplished without the aid of switches or like devices.

20 A further object consists in providing a receiving system in which a characteristic frequency reception curve having staggered or an odd number of resonance peaks is varied in width by commonly mechanically moved electrical units having no conductive electrical connection

25 with the other circuits in the system. These and other objects will be apparent from the following, reference being had to the accompanying drawings in which like reference numerals designate corresponding parts throughout and in which:

30 Fig. 1 is a schematic representation of the circuit system employed in my invention;

Fig. 2 is a representation of one embodiment of the mechanical structure employed in part

35 of my receiving system;

Fig. 3 is a horizontal sectional view along the line 3-3 of Fig. 2;

Fig. 4 is a horizontal sectional view along the line 4-4 of Fig. 2; and

40 Fig. 5 is a graphical representation of certain characteristics of the receiving system according to my invention.

My invention contemplates providing a radio receiving system, preferably of the superheterodyne type, in which the input and output of the intermediate frequency amplifier includes filter networks of the inductively coupled type. Within each filter, according to my invention, there is provided a circuit unit including the

50 primary of one radio frequency transformer and the secondary of another radio frequency transformer. The primary and secondary are interconnected to have special resonance characteristics and are also specially mechanically mounted

55 so that the primary and secondary coils can be

moved relative to their associated windings to vary coupling effects and thereby accomplish variations in the overall frequency transmission band of frequencies being handled by the intermediate frequency amplifier. The transmission characteristics of these filters are such that they simulate the effect of an odd number of resonance circuits staggered with respect to each other along the frequency spectrum. Although various odd numbers of such resonance peaks may be employed according to my invention, I prefer, in the present embodiment, to illustrate the use of a system characterized by three such peaks.

Referring to the drawings in detail, and particularly to Fig. 1, the mixer 1 is connected with circuit means usually to be found in a superheterodyne receiver ahead of the intermediate frequency amplifier. This circuit means connected with the mixer 1 includes a high frequency amplifier and high frequency reception circuits as well as the local oscillator for producing oscillations to beat with the received high frequencies to produce the intermediate frequencies for reception over the intermediate frequency amplifier. The output of the mixer 1 is directed to an input filter circuit 2 which is of the inductively coupled type and includes an inductance 3 coupled with inductance 4 and inductance 5 coupled with inductance 6. A variable capacitor 7 is in circuit with the inductance 3 while a variable capacitor 8 forms part of the circuit connections between inductances 4 and 5. Another variable capacitor 9 is connected in circuit with the inductance 6. These capacitors are of the trimmer type usually to be found in such organizations. The inductance 6 forms part of the filter output circuit which includes a terminating impedance 10 and is connected with the input of the intermediate frequency amplifier proper which includes an electron amplifier tube 12. The output of electron amplifier tube 12 is connected, with the input of the output filter circuit 11 which is similar to the input filter circuit 2. The output of this filter circuit 11 is then connected with the usual detector and audio amplifier system 14 and thence to a reproducing loud speaker 15. A power supply 17 is provided in the usual manner for energizing the various electron tubes as well as the loud speaker 15.

Referring to Fig. 2, the mechanical structure of a portion of the receiving system will now be considered. The inductances 3 and 6 are mounted on supporting members 22 and 23 which are secured to a mounting member 24. A shield-

ing element 21 extends between the coils 3 and 6 as shown. Coils 3 and 6 are positioned for inductive coupling with coils 4 and 5 which are respectively mounted by supporting members 24 and 25 carried by a mounting member 27. The mounting member 27 is secured by nuts 28 to a shaft 29 rotatably mounted in the shield 21. The capacitor 8 is mounted on the other side of the mounting member 27 while the capacitors 7 and 9 are included in a structural unit secured to the end of the shield 21.

The entire mechanical structure thus described is mounted within an enclosing shield 30. The shaft 29 extends through the mounting member 24 and is mechanically integral with a crank 31 which is connected with a reciprocative member 32 so that reciprocative forces from member 32 can be translated into rotary motion of the shaft 29. Such rotary motion causes the spatial relationship between the coils 3 and 4 and between the coils 6 and 5 to be varied, thus varying the inductive coupling between these coils. This condition may be seen particularly in Fig. 3 in which the coils have been so rotated.

Referring back to Fig. 1, it will be seen that the reciprocative member 32 is provided for interconnecting the rotatable shafts 29 and 29a in the two filter systems on the input and output sides of the intermediate frequency amplifier tube. By such an arrangement, it is possible to vary the coupling in both filter systems in unison. Any convenient form of knob or dial can be utilized for controlling the movement of the shaft 32 in the structural arrangement of the radio receiver.

Referring to Fig. 5, consideration will now be given to the electrical characteristics of the radio receiver of my invention. The curves X, Y, and Z are a family showing the transmission frequency characteristic of my radio receiving system for different degrees of coupling produced by different rotative spatial relationship of the coils 4 and 5 in the filter 2 and filter 11. Referring first to curve Z, it will be seen from the curve that the frequency band width here is quite wide, while the frequency band width of curve X is relatively narrow, the curve Y being intermediate such widths. The curve Z represents close spatial relationship of the inductance while the curve X represents the opposite. Thus, when it is desired to receive a narrow band of frequencies for program reception purposes, the shaft 32 may be moved to vary the spatial relationship of the coils 4 and 5 with respect to their associated coils so that the frequency transmission of the filter assumes a characteristic such as represented by the curve X. On the other hand, to obtain a wider band of frequencies, the spatial relationship of the coils may be adjusted to obtain a characteristic represented by the curve Z. It is an especial feature that the mechanical structure of my invention makes it possible to maintain the filter circuits as a structural unity with the variable means enclosed as a single moving unit without any physical or conductive connection with the rest of the filter circuit, thus avoiding the use of movable contactors and inductance taps and the like.

It will be seen that the curve Z has substantially three resonance peaks to the points  $Z_a$ ,  $Z_b$  and  $Z_c$ , while the other curves X and Y have similar resonance peaks but not quite so pronounced, due to the narrower width of these bands. It is known in the art that filter cir-

cuits can be adjusted to achieve certain resonance characteristics and in accordance with my invention the filter circuits in my system are adjusted to produce the resonance characteristics indicated in Fig. 3. It will of course be understood that other types of circuits can be employed using other arrangements of other networks. For example, I might employ a long series of coupled circuits as well as other forms of networks. I have found that such an arrangement of resonance peaks offers considerable improvement in quality. The attenuation of the side bands corresponding to modulation frequency at around 2300 to 3000 cycles tends to compensate for the increase in resonance which is usually present in loud speakers at these frequencies. The speaker 15 has such a resonance characteristic. Another feature is that the carrier is not attenuated with respect to the side band frequencies and so does not tend to produce distortion and demodulation at high percentages of modulation.

For certain purposes, in accordance with the principles of my invention, the terminating impedances 10 and 10a of the filter systems 2 and 11 may be adjusted in value as indicated by the arrows in Fig. 1. The relative amplitude of the resonance peaks is a function of the terminating impedances. In accordance with my invention, therefore, the values of the terminating impedance for each filter system are made variable so that a proportionality can be maintained between the reactance values in each filter circuit and the respective value of terminating impedance. It should also be noted that the three resonance peaks may be made to vanish by using a suitably low value of terminating impedance.

It will now be apparent that I have provided a novel form of receiving organization which is directed to both improvements in electrical reception characteristics and in mechanical arrangements for producing variable band effects in selection operation. Although I have shown a preferred embodiment of my system it will be apparent that changes can be made therein by those skilled in the art without departing from the intended scope of my invention. I do not, therefore, desire to limit myself to the foregoing except insofar as may be pointed out in the appended claims.

What I claim as new and desire to secure by Letters Patent of the United States is:

1. In an electrical filter system, a selection circuit comprising at least two resonant sections and including an intermediary circuit comprising reactive elements for passing frequencies within a predetermined band, said intermediary circuit being coupled with adjacent sections of said selection circuit solely by reactive or non-conductive coupling of said reactive elements in said intermediary circuit, and mechanical means for mechanically varying the spatial relationship of said reactive elements of said intermediary circuit as a unit with respect to the remainder of said selection circuit for effecting a variation in the frequency band width characteristics of said selection circuit as a whole, and an electrostatic shielding extending between said sections of said selection circuit.

2. The combination in accordance with claim 1 in which said reactive coupling is entirely inductive, and in which said selection circuit includes inductances, and said intermediary circuit includes inductances coupled with said first men-

tioned inductances, said mechanical means comprising means for relatively moving said inductances.

3. In an electrical filter system, a selection circuit comprising at least two resonant sections and including an intermediary circuit comprising reactive elements for passing frequencies within a predetermined band, said intermediary circuit being coupled with adjacent sections of said selection circuit solely by inductive coupling, said selection circuit including inductances and said intermediary circuit including inductances coupled with said first-mentioned inductances, and mechanical means for mechanically varying the spatial relationship of the inductances of said intermediary circuit as a unit with respect to the remainder of said selection circuit for effecting a variation in the frequency band width characteristics of said selection circuit as a whole, said mechanical means comprising a unitary structure carrying said second-mentioned inductances and an arrangement for rotating said unitary structure to change the position of the inductances carried thereby with respect to said first-mentioned inductances, said resonant sections and said intermediary circuit all being tuned to a definite frequency band subject to variation of width in accordance with the coupling between

said inductances as determined by said mechanical means.

4. The combination in accordance with claim 1 in which said reactive coupling is entirely inductive and in which said selection circuit includes inductances and said intermediary circuit includes inductances coupled with said first mentioned inductances, said mechanical means comprising a unitary structure carrying said second mentioned inductances and an arrangement for moving said unitary structure to change the spatial relationship of said second mentioned inductances with respect to said first mentioned inductances.

5. The filter system in accordance with claim 3 in which said selection circuit as a whole has a frequency transmission response including an odd number of resonance peaks.

6. In a radio receiving system, a plurality of selection circuits each having an intermediary band-pass filter circuit coupled with its respective selection circuit only by reactive coupling, mechanical means for moving said intermediary circuits as a whole in unison for changing their frequency band width characteristics, and means for electrostatically shielding different parts of said intermediary circuit from each other.

RICHARD C. CURTIS.