

M. J. TRUMBLE.
 EVAPORATOR FOR PETROLEUM OILS OR OTHER LIQUIDS.
 APPLICATION FILED APR. 5, 1910.

996,736.

Patented July 4, 1911.

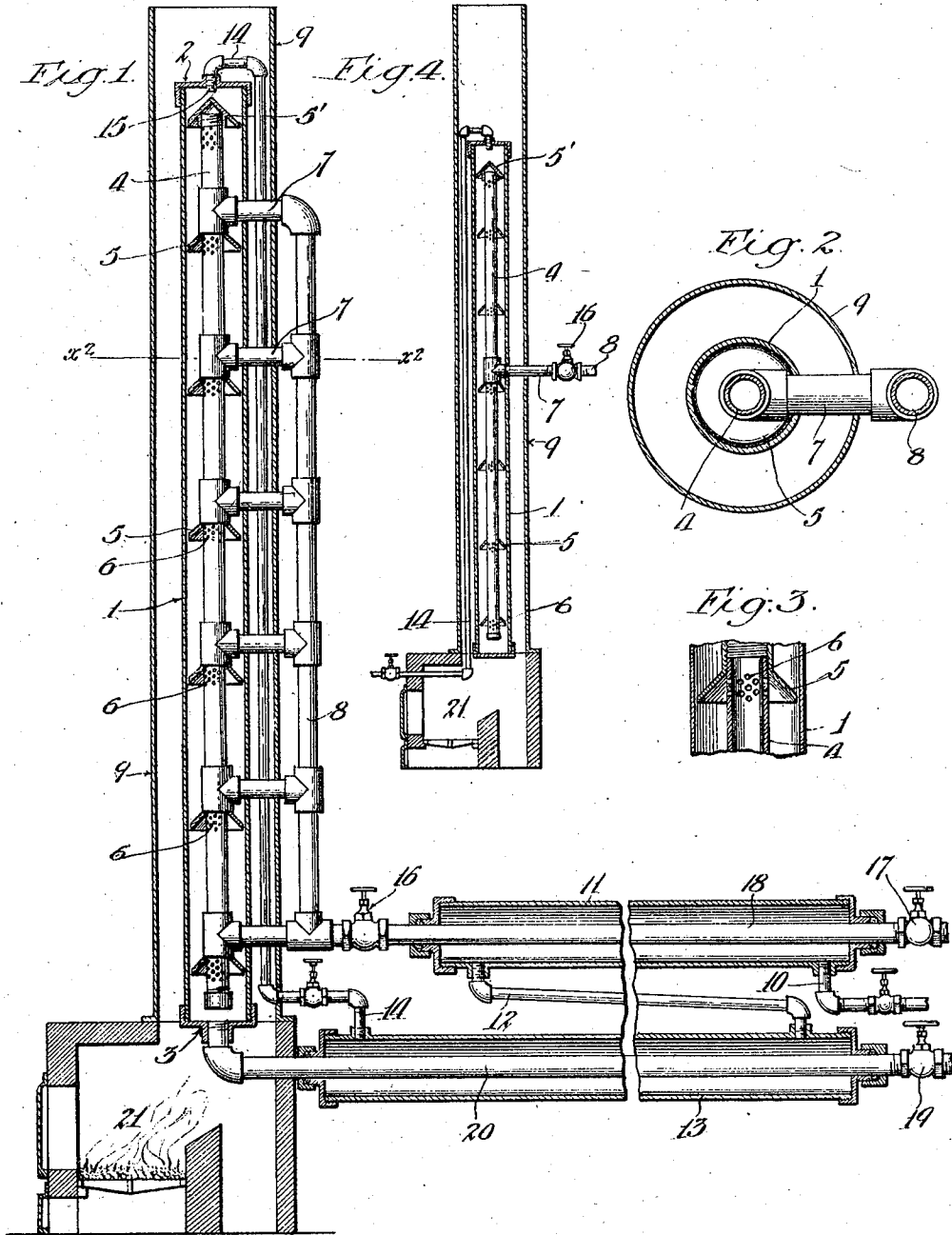

Witnesses:-
 Louis W. Gratz,
 Lester H. Palmer.

Inventor
 Milton J. Trumble
 Raymond Franz Haeberly, atty.

UNITED STATES PATENT OFFICE.

MILON J. TRUMBLE, OF LOS ANGELES, CALIFORNIA, ASSIGNOR, BY MESNE ASSIGNMENTS, TO TRUMBLE REFINING COMPANY, OF LOS ANGELES, CALIFORNIA, A CORPORATION OF CALIFORNIA.

EVAPORATOR FOR PETROLEUM-OILS OR OTHER LIQUIDS.

996,736.

Specification of Letters Patent.

Patented July 4, 1911.

Application filed April 5, 1910. Serial No. 553,656.

To all whom it may concern:

Be it known that I, MILON J. TRUMBLE, a citizen of the United States, residing at Los Angeles, in the county of Los Angeles and State of California, have invented a new and useful Evaporator for Petroleum-Oils or other Liquids, of which the following is a specification.

My invention is especially designed for causing the evaporation of liquids in a rapid and efficient manner.

An object of my invention is to provide an evaporator in which the liquid to be evaporated is applied to the heating surface in a thin film to more readily absorb heat to cause evaporation of the liquid.

Another object of my invention is to provide means in an evaporator which will at all times cause the liquid to be evaporated to be kept in contact with a heated surface.

Another object of my invention is to provide in an evaporator of the character described, means whereby the vapor may readily pass from the evaporator.

Further objects and advantages of my invention will appear from the following specification.

The accompanying drawings illustrate a preferred form of my invention.

Figure 1 is a vertical, longitudinal section of an apparatus designed and arranged especially for the distillation of petroleum oils. Fig. 2 is a horizontal section on line x^2-x^2 of Fig. 1. Fig. 3 is an enlarged fragmental section of the evaporating chamber and the vapor intake, together with the spreader means. Fig. 4 is a modification of my invention particularly adapted for the entire evaporation of water or similar liquid.

1 indicates a vertical closed cylindrical shell or chamber adapted to sustain pressure having a closure 2 at the upper end.

3 is a residuum outlet at the bottom of the chamber shown in Fig. 1.

4 is a vapor take-off centrally located within the chamber 1 and is arranged to collect the vapors within the chamber.

5, 5, 5 are liquid spreaders or distributors, and as shown are formed as hoods surrounding the vapor take-off 4 and are spaced apart at suitable distances therealong to spread the liquid at close intervals.

6, 6, 6 are perforations in the vapor take-off 4 arranged beneath the liquid spreaders.

7, 7 are branches connecting the vapor take-off with the lead pipe 8 on the exterior of the heating chamber 9.

Referring to the oil evaporator shown in Fig. 1, 10 is an oil supply pipe arranged to deliver oil into a casing or drum 11, from which it is drawn by pipe 12 into the casing or drum 13.

In the form shown in Fig. 1, 14 is a pipe communicating at one end with the casing 13 and at its other end with the top of the vertical shell 1 through a nipple 15 to deliver the liquid onto the top of the upper hood shaped spreader 5', while in the form shown in Fig. 4 such pipe may connect with any suitable source of liquid supply. 16 indicates a valve to control the flow of vapors from the evaporator. 17 is a valve arranged beyond the casing 11 on the condensate pipe 18 which passes through the casing 11. The residuum from the chamber passes out through the outlet 3 and through the pipe 20. 19 is a valve arranged to control the flow of liquids through such residuum pipe 20. 21 indicates a fire box.

I will first describe my invention as illustrated in Fig. 1 and used in the operation of distilling liquid hydrocarbons. Oil is supplied through the pipe line 10 to the casing 11 which surrounds the condensate pipe 18. The cold oil will absorb heat from and condense the vapors passing through such pipe; thereby heating the oil. The oil passes from the casing 11 into the casing 13 where it absorbs heat from the residuum passing through the pipe 20. The oil having been heated by its passage through the casing 11 and 13 passes from the casing 13 into the feed pipe 14 and enters the top of the vertical evaporating chamber through the nipple 15 and is delivered upon the top spreader 5'. The spreader 5' deflects the oil outwardly against the inner walls of the chamber and it flows down along such walls in a thin film and absorbs heat which is applied to the exterior of the vertical chamber. By providing a series of the spreaders, spaced apart, as shown, the liquid is carried outwardly and brought into contact with the inner walls of the evaporating chamber and kept flowing down the walls of the chamber in a thin film. The vapor from the liquid will enter the vapor take-off through the perforations 6 below the spread-

ers 5, 5 and 5' and will pass outwardly into the vapor line 8 through the branches 7 and into the condensing pipe 18 in the casing 11 and will give up heat to the body of cold oil surrounding the vapor line, and the condensed vapors will be drawn off through the valve 17. The residuum will pass out of the chamber through the outlet 3 and be carried by the pipe 20 through the casing 13 where the oil surrounding such pipe will absorb heat from the residuum.

In Fig. 4 I have shown a modification of my invention insofar as the casings 11 and 13, and the outlet 3, and residuum pipe 20 are dispensed with and only one branch from the take-off is employed. This form is especially adaptable for the evaporation of water or liquids of a like nature, that is to say, liquids which are wholly evaporated within the chamber and from which there is no residuum. I have not shown any means for condensing the vapors generated in this form for the reason that it may be used as a steam generator for power purposes.

In the accompanying drawings, I have illustrated the means for applying heat to my evaporator as a vertical heating chamber, such as 9, adapted to receive the heat from a fire box 21. But other forms of applying heat to the evaporator will readily suggest themselves to those skilled in the art and I do not consider it necessary to illustrate all forms of means for the application of heat to which my invention is susceptible.

The spreaders 5 are arranged or spaced at a distance from the walls of the vertical chamber which will insure the bringing of all the liquid in passing downwardly through the vertical evaporating chamber against such wall. In the event any of the liquid should be thrown toward the center of the chamber through any bubbling or boiling action, such liquid will be caught upon the next spreader or will if it strikes the vapor take-off line run downwardly therealong until it encounters the succeeding spreader and will then be again carried out into contact with the wall.

Other means for distributing the oil will readily suggest themselves to those versed in the art, and I have therefore shown only one form in the drawings.

By arranging the perforations 6 beneath hood spreaders, such as shown, I am enabled to provide outlets for the vapors generated and prevent such outlets from becoming stopped up or closed in any way on account of oil or liquid flowing over such perforations, and I consider this as a preferable manner of allowing the vapors to be drawn from the evaporator.

The form shown in Fig. 1 is especially adapted for distilling or topping oils pro-

duced in the State of California and elsewhere wherein a large percentage of water is contained in such oil in the form of an emulsion and I am enabled by the use of my evaporator to rapidly and economically evaporate the lighter liquid hydrocarbons from such oils, as well as evaporating the water contained therein. By the use of my evaporator in evaporating the oils from California petroleum wells, I avoid all liability of such oils "puking" or "spuing" from the still, thereby materially reducing the expense of the distillation of such oils.

By means of my device I am enabled to bring the liquid to be evaporated into absorbing contact with a heated surface in a thin film, thereby heating the entire body of liquid in contact with the heating surface and allowing the vapors of such liquid to pass away from the liquid without being compelled to penetrate or rise through a body of the liquid in order to escape from such liquid. This action is especially desirable in the treatment of oils carrying water in emulsion as it allows the water to evaporate from and be carried away from the oil without causing bubbling or foaming, which is the cause of stills heretofore used "puking" when used upon that class of oils.

By causing the oil to travel in a thin film along the walls of a heated chamber the deposit of carbon due to freeing the hydrogen by evaporation from the oil is prevented, as any small atoms of carbon will be carried down with the rapidly flowing film of oil and pass off through the residuum outlet pipe at the bottom of the chamber. The accumulation of carbon has been a very serious obstacle to the continuous operation of stills for evaporating hydrocarbons as heretofore used, and by my invention this objection is entirely obviated. I regard this as a very important feature of my invention.

When the form shown in Fig. 4 is employed as a steam generator for power purposes, the water feed thereto through pipe 14 is under pressure and the supply thereof is regulated to the amount required to furnish the steam used.

What I claim is:—

1. In a liquid evaporator, a closed chamber having a substantially vertical wall, means arranged to spread a liquid over the wall of such chamber, means for delivering a liquid into the chamber above the liquid spreading means, a vapor take-off arranged within the chamber, a lateral branch connecting with such vapor take-off to convey the vapors to the exterior of the chamber, and means for heating the wall of the chamber.

2. In a liquid evaporator, a closed chamber having a substantially vertical wall,

- means arranged to spread a liquid in a thin film over the inner wall of the chamber, a vapor take-off arranged within the chamber and having outlet means from such chamber, means for supplying a liquid to the chamber, and means for heating such chamber.
3. In a liquid evaporator, a closed chamber having a substantially vertical wall, means for heating the exterior of such chamber, means for continuously supplying a liquid to such chamber, means arranged within the chamber to direct the liquid fed therein against the wall thereof, a vapor take-off arranged within the chamber and at a distance from the wall thereof, branch means connecting with such vapor take-off and passing outwardly through the wall of the chamber, and means for regulating the flow of vapors from the chamber.
4. In a liquid evaporator, a closed chamber, means for feeding a liquid into the top of such chamber, a centrally arranged vapor take-off pipe in the chamber, a liquid spreader surrounding the vapor pipe and arranged to spread a liquid against the wall of the chamber, means for leading vapors from the vapor pipe, and means for supplying heat to the exterior of the chamber.
5. In a liquid evaporator, a closed chamber, means for feeding a liquid into the chamber, a spreader hood arranged within such chamber and below the liquid feed, such hood being arranged to spread the liquid fed into the chamber over the wall thereof in a thin film, and vapor take-off means arranged to take off vapors beneath such hood.
6. In a liquid evaporator, a closed chamber, a vertical vapor take-off pipe arranged in such chamber, a spreader hood supported by such take-off pipe, and means for feeding oil into the chamber and onto the spreader hood.
7. In a liquid evaporator, a closed chamber, a vertical vapor take-off pipe arranged in such chamber, a plurality of spreaders carried by such vapor take-off pipe, and means for feeding a liquid into such chamber above the spreaders.
8. In a liquid evaporator, a closed chamber, a vertical vapor take-off pipe arranged in such chamber, a spreader carried by the take-off pipe, means for feeding a liquid into the chamber and onto the spreader, and means for admitting vapors to the take-off pipe arranged below the spreader.
9. In a liquid evaporator, a closed chamber, means for feeding a liquid thereto, a vertical perforated vapor take-off pipe in the chamber, spreaders arranged within the chamber and adapted to spread a liquid over the wall thereof, means arranged above the perforations in the vapor take-off pipe to prevent a liquid from flowing thereover, and means connecting with the vapor take-off pipe to convey the vapors away from the chamber.
10. In a liquid evaporator, a closed chamber, a vertical perforated vapor take-off pipe in the chamber, a plurality of spreaders within the chamber arranged to spread a liquid over the walls of the chamber in a uniform flowing film, means for preventing the liquid from contacting with the perforations in the perforated vapor take-off pipe, and means for feeding a liquid into the chamber above the spreaders.
11. In a liquid evaporator, a vertical closed chamber; means for feeding a liquid into the top of such chamber, spreaders spaced apart one below another within the chamber, and below the liquid feed, such spreaders being all adapted and arranged to spread a liquid in thin film like form over the wall of the chamber, and vapor take-off means arranged to convey vapors from the chamber.
12. In a liquid evaporator, a closed chamber, means for feeding a liquid into the top of such chamber, a vertical vapor take-off pipe having a series of perforations therein arranged centrally within the chamber, spreader hoods mounted upon and carried by such take-off pipe and arranged to deflect and spread a liquid over the walls of the chamber in film like form, such spreader hoods being arranged respectively above the respective perforations in the take-off pipe, whereby the liquid is prevented from flowing over such perforations in the vapor take-off pipe.
13. In a liquid vaporizer, a closed chamber having a substantially vertical wall, means for heating the chamber, means for feeding liquid into the top of the chamber, distributors arranged at spaced points along the chamber to cause the liquid to flow in a film over the wall of the chamber, and a plurality of vapor outlets located at suitable points along the chamber for effecting an escape of the vapors.
- In testimony whereof, I have hereunto set my hand at Los Angeles, California, this 30th day of March 1910.

MILON J. TRUMBLE.

In presence of—
 F. M. TOWNSEND,
 FRANK L. A. GRAHAM.