

(No Model.)

C. HARMAN.

ROCK OR WELL DRILLING MACHINE.

No. 372,143.

Patented Oct. 25, 1887.

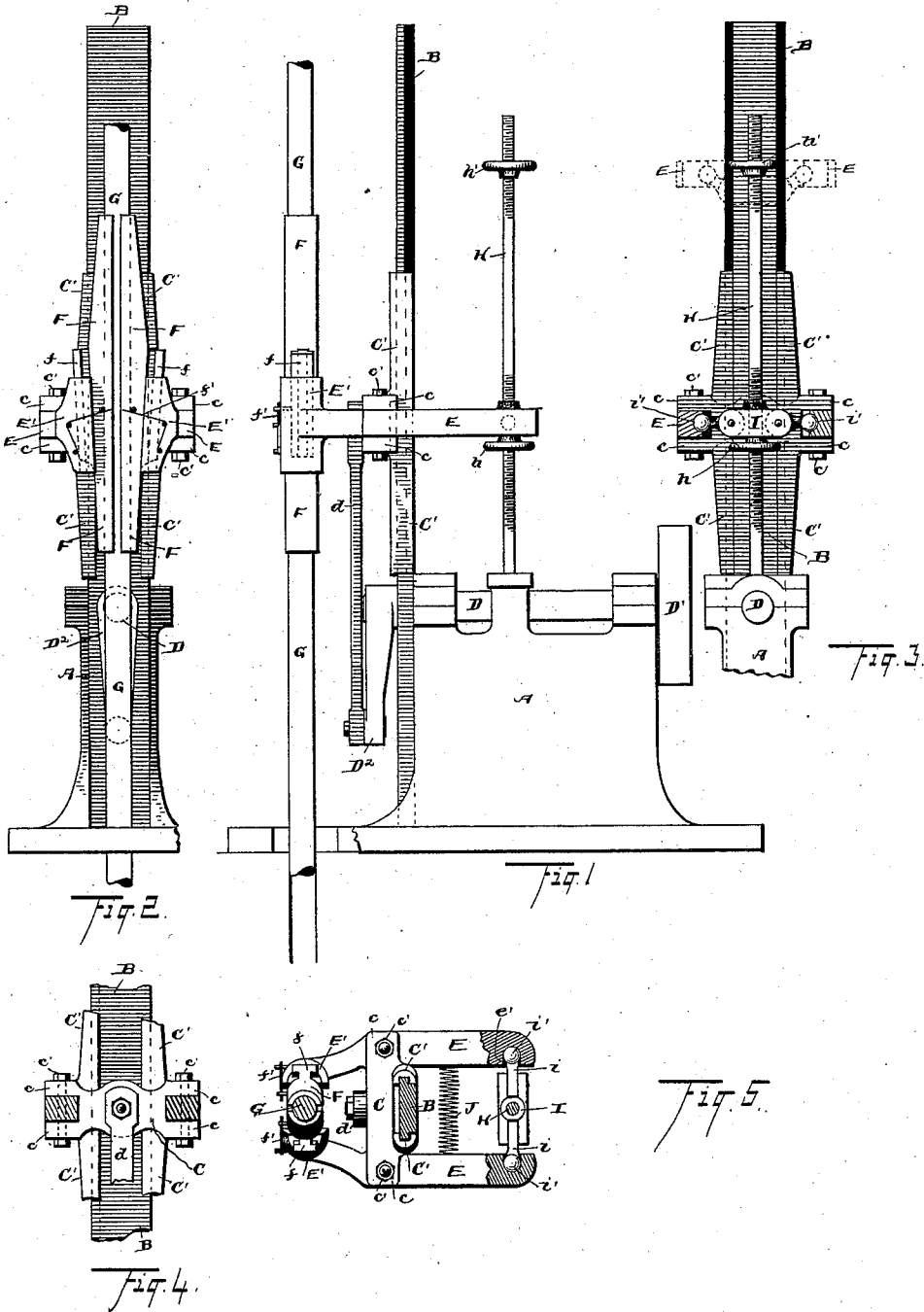

WITNESSES
W. S. Ametutz
Geo. W. King

Chas. Harman INVENTOR
Siggell, Siggell
Attorneys

UNITED STATES PATENT OFFICE.

CHARLES HARMAN, OF TIFFIN, OHIO.

ROCK OR WELL DRILLING MACHINE.

SPECIFICATION forming part of Letters Patent No. 372,143, dated October 25, 1887.

Application filed April 23, 1887. Serial No. 235,910. (No model.)

To all whom it may concern:

Be it known that I, CHARLES HARMAN, of Tiffin, in the county of Seneca and State of Ohio, have invented certain new and useful
5 Improvements in Rock or Well Drilling Machines; and I do hereby declare the following to be a full, clear, and exact description of the invention, such as will enable others skilled in the art to which it pertains to make
10 and use the same.

My invention relates to improvements in rock-drilling apparatus; and it consists in certain features of construction and in combination of parts hereinafter described, and pointed
15 out in the claims.

In the accompanying drawings. Figure 1 is a side elevation of my improved drilling-machine. Fig. 2 is a front end elevation of the same. Fig. 3 is a rear end elevation. Fig. 4
20 is a front end elevation with the clutch mechanism removed, the clutch-levers showing in transverse section. Fig. 5 is a plan view.

A represents a suitable supporting-base, to which is rigidly attached an upright bar, B, the edges of the latter serving as ways for the
25 vertically-reciprocating cross-head C.

D is the driving-shaft, the same being journaled in suitable boxes connected with the base. This shaft is provided with a driving-pulley,
30 D', or with other mechanism for transmitting power to the shaft. Mounted on the other end of the shaft is the crank D'', the latter being connected by pitman *d* with a cross-head, C, for reciprocating the latter. The cross-head
35 has gibs C', of considerable length, to give ample wearing-surface and to insure a steady movement of the cross-head on the ways as against a rocking tendency of the cross-head. The ends of the cross-head extend outside of
40 the line of the gibs. These projecting ends are slotted, forming jaws *e*, for receiving, respectively, horizontal levers E, bolts or pins *e'* being made to extend through the respective levers E and the embracing-jaws *e*, such bolts
45 or pins forming fulcrums for the levers. These levers at the front end terminate in heads E', for holding the clamping-jaws F. These jaws on their inner faces are grooved lengthwise to approximately fit the drill-rod G, and on their
50 outer faces have ribs *f*, inclined, as shown, to the inner faces of the jaws. These ribs in cross-section are preferably T-shaped and op-

erate in correspondingly-shaped and inclined grooves *e*, made in the heads E', as shown in
Figs. 2 and 5. With the heads E' held station-
55 ary, it is evident that by reason of the inclined ways *f* the jaws F may be made to approach or recede from each other by depressing or elevating these jaws.

Springs *f'* are located substantially as shown
60 in Fig. 2, and are connected, respectively, with heads E', and engaging-jaws F, to hold the latter in their normal or elevated position, with the center of the jaws somewhat above the
65 center of the heads. These heads, when made to approach each other by the operation of a toggle-joint located at the rear end of the levers E, and hereinafter described, close the jaws F sufficiently with the latter in their normal or
70 elevated position to grasp and elevate a drill-rod of moderate length. If, however, the drill-rod in drilling deep holes has been lengthened and its weight thereby increased, so that the grasp of the jaws, with the latter in their normal position in the heads, will not elevate the
75 drill-rod, the jaws, as the cross-head commences its upward movement, slide downward in the heads E', and by reason of the inclined ways *f* the jaws are wedged against the drill-rod with a force greater or less, according to
80 the weight of the latter, but always sufficient to preclude the possibility of the drill-rod slipping between these jaws. When the jaws have opened by the collapse of the toggle-joint aforesaid, the spring *f'* at once elevates the jaws to
85 their normal position. The said toggle-joint and connected mechanism are as follows: H is an upright rod located midway between the levers E and near the rear end of the latter. The rod is rigidly secured to the bed. The up-
90 per and lower portions of the rod are screw-threaded, and provided with jam-nuts or tappets *h* and *h'*, the latter being screw-threaded, making them adjustable lengthwise of the rod. These tappets form abutments for the sleeve I,
95 the latter being made to slide on the rod H. To opposite ends of this sleeve are jointed short arms *i*, these joints being such as to allow the arms to swing in a vertical plane from the position shown in solid lines, Fig. 3, where
100 the arms are extended in line with each other, to the position shown above in dotted lines, where the arms are in the inclined position. The outer ends of the arms *i* terminate in ball-

bearings *i'*, that are seated in corresponding sockets, *e'*, made on the inner faces of the levers E.

Near the lower end of the downstroke of the cross-head the sleeve I strikes the tappets *h*, after which, as the cross-head descends a little farther, the arms *i*, by their engagement with the levers E, are tilted downward and brought in line with each other, such distention of the arms *i* of course causing an outward movement of the engaging end of the levers E, thereby causing the forward ends of these levers to approach each other, causing the jaws F to grip the drill-rod. In this position of parts the drill-rod is elevated with the cross-head. Near the end of the upward movement of the cross-head the sleeve I strikes the tappet *h'*, causing the arm *i* to be tilted to the inclined position shown in dotted lines, Fig. 3, the rear ends of the levers being drawn toward each other by the tension of the spring J, the latter being located just inside the line of the toggle-joint in position extending from one lever E to the other, and being attached to both levers. With this construction the tension of the spring J prevents lost motion of the parts, as would otherwise occur from wear in case the levers E were moved in both directions by the action of the toggle-joint.

In operating the machine, by revolving the shaft D the cross-head C is reciprocated, and by means of the mechanism hereinbefore described the drill is lifted with the upward movement of the cross-head and allowed to fall by gravity when the cross-head has reached the end of its upstroke.

What I claim is—

1. The combination, with a vertically-reciprocating cross-head and suitable crank and pitman for operating the same, of horizontal levers pivoted to the cross-head, said levers having jaws mounted thereon for grasping the drill-rod, a toggle-joint for operating the said levers, and tappets arranged above and below the toggle-joint for operating the latter, substantially as set forth.

2. The combination, with a vertically-recip-

rocating cross-head, levers pivoted to the cross-head, and toggle-joints for operating the levers, substantially as indicated, of jaws mounted on the said levers, the said jaws having inclined ways made to operate in corresponding ways in the respective heads of the levers, the ways of a pair of jaws being made to converge as they extend downward, substantially as set forth.

3. The combination, with a cross-head, levers pivoted to the cross-head, and jaws mounted on the levers for grasping the drill-rod, the parts being arranged substantially as indicated, of a toggle-joint for pressing one end of the levers outward and a spring connected with the levers and made to act in apposition with the thrust of the toggle-joint, substantially as set forth.

4. The combination, with a vertically-reciprocating cross-head, lateral arms pivoted to the cross-head, jaws mounted on the levers for grasping the drill-rod, and a toggle-joint for operating the levers, substantially as indicated, of a sleeve connected with the toggle-joint and made to slide on an upright stationary rod, and adjustable tappets mounted on the rod for engaging the sleeve to operate the toggle-joint, substantially as set forth.

5. The combination, with cross-head, levers, toggle-joint, and mechanism for operating the latter, substantially as indicated, of jaws mounted on the said levers for grasping the drill-rod, said jaws having inclined ways converging downward, said ways being made to operate in corresponding grooves of the lever-heads, springs connected with the respective lever-heads, and engaging-jaws to hold the latter, when free, in their normal or elevated position, substantially as set forth.

In testimony whereof I sign this specification, in the presence of two witnesses, this 5th day of March, 1887.

CHARLES HARMAN.

Witnesses:

WM. HARMAN,
W. H. BLASIUS.